

⑫ **EUROPEAN PATENT SPECIFICATION**

- ⑬ Date of publication of patent specification: **23.08.89** ⑭ Int. Cl.⁴: **E 02 D 1/02, E 02 D 11/00**
⑮ Application number: **82201654.9**
⑯ Date of filing: **23.12.82**

⑰ **A soil investigation device.**

- | | |
|--|---|
| <p>⑱ Priority: 26.12.81 NL 8105859</p> <p>⑲ Date of publication of application:
06.07.83 Bulletin 83/27</p> <p>⑳ Publication of the grant of the patent:
23.08.89 Bulletin 89/34</p> <p>㉑ Designated Contracting States:
AT BE CH DE FR GB IT LI LU NL SE</p> <p>㉒ References cited:
DE-A-2 545 692
FR-A-2 018 186
US-A-2 774 240
US-A-3 331 240
US-A-3 379 052
US-A-3 960 448
US-A-4 033 186</p> | <p>㉓ Proprietor: Ingenieursbureau A.P. van den Berg B.V.
IJzerweg 4
NL-8445 PK Heerenveen (NL)</p> <p>㉔ Inventor: van den Berg, Arie Pieter
Van-Goghlaan 38
NL-8442 HW Heerenveen (NL)</p> <p>㉕ Representative: Mommaerts, Johan Hendrik,
Dipl.-Phys.
Octrooibureau Lux Willem Witsenplein 4
NL-2596 BK Den Haag (NL)</p> |
|--|---|

Note: Within nine months from the publication of the mention of the grant of the European patent, any person may give notice to the European Patent Office of opposition to the European patent granted. Notice of opposition shall be filed in a written reasoned statement. It shall not be deemed to have been filed until the opposition fee has been paid. (Art. 99(1) European patent convention).

EP 0 083 141 B1

Description

The invention relates to an apparatus as defined in the preamble of claim 1.

Such an apparatus is known from US-A 3331240, showing a hand-driven apparatus for soil sounding purposes, and in particular for the so-called vane test in which the rod driven into the ground, which is provided with transverse vanes at its lower end, is to be rotated.

Such a device is not suitable for working at greater depths, since the friction between the flanged wheels is restricted. Although the friction can be increased by increasing the pressure between said wheels and the rod, this is restricted by the strength of the materials in question, in particular if hollow rods are to be used.

The invention provides an apparatus of this kind which is suitable for being used at larger depths, which is characterised by the features mentioned in the characterising portion of claim 1.

Such driving units having individual driving motors can be superposed along the rod to be driven, and the number thereof or the number of units in operation can be adapted to the required driving force. Said force is, then, distributed along said rod so that overstressing said rod is avoided.

The rod can be pressed into the ground in a continuous manner, and it is possible to arrange extension rods without interrupting the device.

In particular in the case of remotely controlled devices of this kind, the auxiliary means according to claims 2..6 will simplify the operation of such devices.

The invention will be elucidated in more detail below by reference to a drawing, showing in:

Fig. 1 a diagrammatic top view of an embodiment of an apparatus according to the invention;

Figs. 2A, B and C highly simplified representations of auxiliary means to be used with such an apparatus;

Fig. 3 a simplified representation, partly in section, of a cutting tube to be used together with such an apparatus; and

Fig. 4 a diagrammatic cross-section of a simple inclination sensor for such an apparatus.

Fig. 1 shows an embodiment of the apparatus of the invention for pressing a tube 1 into the soil, comprising a unit 31 forming the essential part thereof. This apparatus however, is provided with means (not shown) allowing to superimpose a plurality of such units 31 along a tube 1. Each unit 31 comprises a pair of wheels 32 and 33 with an outer rim of substantially semicircular cross-section, which wheels thus define a substantially circular cavity 34 in which a tube to be driven will fit. The wheel rims can be roughened or can be provided with a friction covering in order to increase the grip on such a tube. The wheel 33 is contained in a yoke 35 coupled to a pressure medium cylinder 36 by means of which this yoke can be pressed against the other wheel 32 so as to improve the grip on the interposed tube still more.

The shaft 37 of the wheel 32 is coupled to a driving motor 38 adapted to drive the wheel 32. If a larger driving force is desired, also the shaft 39 of the wheel 33 can be coupled to a motor 40. The driving force can be increased still further by increasing the number of units 31.

Increasing the number of units 31 has the advantage that, then, the driving force is distributed over a corresponding length of the tube 1, and slipping of the wheels 32 and 33, in particular under wet conditions, can be avoided.

Such a unit 31 can be used to drive a tube 1 directly, so as to obtain a substantially continuous drive. Coupling extension tube sections can take place during driving.

For measuring the soil resistance force measuring apparatuses to be mounted on the lower end of tube 1 such as measuring cones or the like with electrical force transducers will preferably be used. The measuring cord is to be strunged through all the tube sections to be used if the use of extension cords with contact plugs and sockets would lead to too high contact resistances. Such measuring cords can, by their nature, be troublesome. The invention provides a number of possibilities allowing to work without such measuring cords.

As shown in Fig. 2A, a central rod 20 can be used instead of a measuring cord, which rod needs not to be slidable, and can be provided, at an extremity, with a fitting 41 in which the extremity of the rod 20' of an adjoining tube section will fit more or less tightly so as to obtain an electrical connection, and the tube sections 1 themselves serve as a return conductor. It can, then, be advisable to arrange the current source 22 for the measuring circuit near the transducer 43 in the lower part of the tube 1, so as to ensure a sufficient voltage near the transducer 43 independent of the contact resistance in the couplings between the rods 20'. The transducer 43 can be provided with a circuit which is adapted to transform the measurement results into suitable measurement signals, e.g. in digital form.

Instead thereof it is also possible to use, for the signal transfer, modulated radiation, and then, as shown in Fig. 2B, the transducer 43 can be connected to a radiation source 44, e.g. a laser diode, which can send directed radiation through the interior of the tube, and at the upper extremity of the tube 1 a radiation receiver, e.g. a photodiode, will be arranged. The tube 1 is, preferably, made as wide as is compatible with the strength of the tube, so as to maintain an unimpeded passage for the radiation even in the case of bending of the tube. It is also possible to polish the inner wall of the tube 1 in such a manner that the radiation will be transferred by successive reflections, and, then, care should be taken that only radiation with a given path length can reach the receiver, and radiation with a different path length is screened there so as to avoid unsharpness in the signal transmission caused by path length differences.

Fig. 2C shows still another solution in which the

transducer 43 is coupled to a memory 45 in which the measurement results can be stored. After the tube is retracted again, the measurement results can be read out from said memory.

Timing signals should be recorded then at the same time so as to allow to relate the measurements to the insertion depth which is continuously recorded above ground, this also with the associated timing signals. Such a memory can, for instance, be formed by a small tape recorder with micro-cassettes.

Such a tube 1 can also be constructed as a sample cutter for taking soil samples. It is usual to counteract disturbance of the soil samples by wall friction by enclosing the sample by a hose. This hose is provided, in the known samplers, in an annular chamber surrounding the tube cavity into which the sample is inserted, and then the hose can enter the central bore at the lower end of this chamber through an annular slot, and the hose is closed there so that a penetrating sample pulls the hose along. Bending the hose around the edge of this slot, however, can lead to damage, and also soil particles can penetrate into this chamber. Therefore sometimes a so-called supporting liquid will be used which is supplied to the hose chamber and facilitates pulling the hose through the slot and, moreover, keeps soil particles out of this chamber. Furthermore this liquid acts as a lubricant for the hose.

According to the invention such a cutting tube can be made in a simple manner as shown in Fig. 3, in which the hose chamber 46 is situated between the cutting mouth 47 at the extremity of the tube 1 and an exit slot 48 for the hose 49, so that the hose can be pulled substantially linearly from the chamber 46. Damaging the hose in the slot 48 is prevented then, and, moreover, penetration of soil particles is prevented. A supporting liquid can, then, be omitted, which considerably simplifies the construction of the over-all device.

In order to drive the tube 1 correctly vertically into the soil, the device should be directed vertically as well as possible. For that purpose the carrier for this device will be provided with means such as piston rods provided with foot plates which can be driven outwards by a pressure medium such as oil, and, by a separate pressure medium supply towards the different cylinders, the correct vertical orientation of said carrier and device can be obtained.

The invention provides means for considerably accelerating these operations and making them independent of human intervention and, thus, of errors. To that end a special sensor shown in Fig. 4 is preferably used. This sensor comprises a substantially cylindrical housing 50 filled with oil, in which a float 51 of insulating material is provided which, by means of a spring 52, is kept in the centre when the housing 50 is directed vertically. In the inner wall of the housing electrical contacts 53 are provided adapted to contact the float 51 as soon as the housing 50 has been removed somewhat from the vertical orientation. The spring 52 is, with these electrical contacts, included in a control circuit by

means of which, in correspondence with the orientation of the float, the pressure medium supply towards the different jacks can be regulated. A fast, automatic and accurate orientation of the device can be obtained thereby.

The device according to the invention can also be used for driving a drainage tape into the ground by means of a protecting tube which is finally retracted again, leaving a wedge-shaped driving end piece to which the tape is attached in the soil.

The device of Fig. 1 allowing a continuous driving force to be exerted is particularly suitable for sounding purposes, as an interrupted movement of a sounding tube may influence the measurement results.

In the embodiment of Fig. 1 the driving motors 38 and 40 can be hydraulic or electric motors.

Claims

1. An apparatus for driving a tube or rod into the ground for soil investigation purposes, comprising means for fixedly supporting the apparatus in respect to the ground, pairs of flanged friction wheels (32, 33) adapted to frictionally engage said tube or rod, at least one of the wheels of a pair being adapted to be rotated by driving means (38, 40) connected thereto, means (35, 36) being provided for clamping the wheels of a pair in an adjustable manner against said tube or rod, characterised by a plurality of self-contained units (31) each consisting of a pair of said flanged wheels (32, 33), associated said clamping means (35, 36), and at least one driving motor (38, 40) for rotating said wheel(s), said plurality, of units being adapted to be superposed along a tube or rod to be driven into the ground, and supply and control means for energising said motor and clamping means of each unit.

2. A driving apparatus according to claim 1 in combination with a plurality of tube sections to be driven into the ground, wherein said tube sections are provided with a central rod, characterised in that the central rods (20) are provided with coupling means (41) adapted for realising an electrical connection between the central rods of adjoining tube sections (1).

3. A driving apparatus according to claim 1 in combination with a plurality of tube sections to be driven into the ground, characterised in that, near the transducers (43) in the lower portion of the sounding tube (1), a radiation source (44), in particular a laser diode, is provided, and at the upper end of the tube (1) an element sensitive for the emitted radiation, in particular a photo-diode, is arranged.

4. A driving apparatus according to claim 1 in combination with a plurality of tube sections to be driven into the ground, characterised in that, near the transducer (43) in the lower portion of the tube, a memory element (45) is mounted, means being provided for registering a timing signal, enabling to relate the measurements to insertion depths recorded above ground.

5 The apparatus of any one of claims 2..4,

adapted to a sounding tube with electric measuring elements characterised in that the current source (42) for the measuring elements (43) is arranged near the lower end of the tube (1).

6. A driving apparatus according to claim 1 in combination with a plurality of tube sections to be driven into the ground, in which the tube is constructed as a sample cutting tube, which, near its lower end, is provided with a chamber surrounding the sample cavity and accommodating a hose, which chamber communicates with the sample cavity by means of an exit slot, characterised in that the sample cavity (46) is situated between the lower end of the tube (1) and the exit slot (48).

Patentansprüche

1. Vorrichtung zum Eintreiben eines Rohres oder einer Stange in die Erde für Bodenuntersuchungen, mit Mitteln zum festen Abstützen der Vorrichtung relativ zur Erde, Paaren von mit Flanschen versehenen Reibrädern (32, 33) zum Reibangriff an dem Rohr oder der Stange, wobei mindestens eines der Räder eines Paares von einem mit ihm verbundenen Antriebsmotor (38, 40) drehbar ist, und wobei Mittel (35, 36) zum einstellbaren Verklammern der Räder eines paares gegen das Rohr oder die Stange vorgesehen sind, gekennzeichnet durch eine Mehrzahl von in sich geschlossenen Einheiten (31), von denen jede ein Paar der mit Flanschen versehenen Räder (32, 33), zugehörige Verklammerungsmittel (35, 36) und mindestens einen Antriebsmotor (38, 40) zum Drehen des Rades (der Räder) umfaßt, wobei die Mehrzahl von Einheiten entlang eines Rohres oder einer Stange, das (die) in die Erde einzutreiben ist, übereinandersetztbar sind, und durch Versorgungs- und Steuermittel zur Energieversorgung des Motors und der Verklammerungsmittel jeder Einheit.

2. Treibvorrichtung nach Anspruch 1 in Verbindung mit einer Mehrzahl von in die Erde einzutreibenden Rohrabschnitten, wobei die Rohrabschnitte mit einer Zentralstange versehen sind, dadurch gekennzeichnet, daß die Zentralstangen (20) mit Kupplungsmitteln (41) zur Herstellung einer elektrischen Verbindung zwischen den Zentralstangen aneinander anschließender Rohrabschnitte (1) versehen sind.

3. Treibvorrichtung nach Anspruch 1 in Verbindung mit einer Mehrzahl von die Erde einzutreibenden Rohrabschnitten, dadurch gekennzeichnet, daß in der Nähe des Wandlers (43) im unteren Abschnitt des Schallrohres (1) eine Strahlenquelle (44), insbesondere eine Laserdiode, vorgesehen ist und daß am oberen Ende des Rohres (1) ein auf die gesendete Strahlung ansprechendes Element, insbesondere eine Photo-Diode, angeordnet ist.

4. Treibvorrichtung nach Anspruch 1 in Verbindung mit einer Mehrzahl von in die Erde einzutreibenden Rohrabschnitten, dadurch gekennzeichnet, daß in der Nähe des Wandlers (43) im unteren Abschnitt des Rohres ein Speicherele-

ment (45) montiert ist, wobei Mittel zum Aufzeichnen eines Zeitsignals vorgesehen sind, um die Meßwerte mit Eintreibtiefen ins Verhältnis zu setzen, die oberhalb der Erdoberfläche aufgenommen werden.

5. Vorrichtung nach einem der Ansprüche 2 bis 4 in Anpassung an ein Schallrohr mit elektrischen Meßelementen, dadurch gekennzeichnet, daß die Stromquelle (42) für die Meßelemente (43) am unteren Ende des Rohres (1) angeordnet ist.

6. Treibvorrichtung nach Anspruch 1 in Verbindung mit einer Mehrzahl von in die Erde einzutreibenden Rohrabschnitten, wobei das Rohr als Probenschneidrohr ausgebildet ist, welches nahe seinem unteren Ende mit einer Kammer versehen ist, die den Probenhohlraum umgibt, einen Schlauch aufnimmt und mit dem Probenhohlraum über einen Auslaßschlitz in Verbindung steht, dadurch gekennzeichnet, daß der Probenhohlraum (46) zwischen dem unteren Ende des Rohres (1) und dem Auslaßschlitz (48) liegt.

Revendications

1. Dispositif pour l'enfoncement d'un tube ou d'une tige dans le sol, pour des applications d'investigation du sol, qui comprend des moyens pour supporter de façon fixe le dispositif par rapport au sol, des paires de roues de friction à gorge (32,33) prévues pour venir en contact de friction avec ledit tube ou ladite tige, au moins une des roues d'une paire pouvant être mise en rotation par des moyens d'entraînement (38,40) accouplés à cette roue, des moyens (35,36) étant prévus pour serrer les roues d'une paire de manière réglable contre ledit tube ou ladite tige, caractérisé par une pluralité de groupes autonomes (31) comportant chacun une paire de dites roues à gorge (32,33), desdits moyens de serrage associés (35,36) et au moins un moteur d'entraînement (38,40) pour entraîner la ou lesdites roues en rotation, ladite pluralité de groupes pouvant être superposés le long d'un tube ou d'une tige à enfoncer dans le sol, et par des moyens d'alimentation et de commande pour actionner ledit moteur et lesdits moyens de serrage de chaque groupe.

2. Dispositif d'enfoncement suivant la revendication 1, en combinaison avec une pluralité de tronçons de tube à enfoncer dans le sol, lesdits tronçons de tube comportant une tige centrale, caractérisé en ce que les tiges centrales (20) comportent des moyens de couplage (41) permettant de réaliser une connexion électrique entre les tiges centrales des tronçons de tube adjacents (1).

3. Dispositif d'enfoncement suivant la revendication 1, en combinaison avec une pluralité de tronçons de tube à enfoncer dans le sol, caractérisé en ce qu'une source de rayonnement (44), en particulier une diode laser, est prévue près des transducteurs (43) dans la partie inférieure du tube de sondage (1), et un élément sensible au rayonnement émis, en particulier une photodiode, est prévu à l'extrémité supérieure du tube (1).

4. Dispositif d'enfoncement suivant la revendication 1, en combinaison avec une pluralité de tronçons de tube à enfoncer dans le sol, caractérisé en ce qu'un élément de mémoire (45) est monté près du transducteur (43) dans la partie inférieure du tube, des moyens étant prévus pour enregistrer un signal de séquençement de temps permettant d'associer les mesures aux profondeurs d'insertion enregistrées au-dessus du sol.

5. Dispositif suivant l'une quelconque des revendications 2 à 4, adapté à un tube de sondage comportant des éléments de mesure électriques, caractérisé en ce que la source de cou-

rant (42) pour les éléments de mesure (43) est prévue près de l'extrémité inférieure du tube (1).

6. Dispositif d'enfoncement suivant la revendication 1, en combinaison avec une pluralité de tronçons de tube à enfoncer dans le sol, dans lequel le tube est sous la forme d'un tube de coupe d'échantillon qui comporte, près de son extrémité inférieure, une chambre entourant la cavité d'échantillonnage et contenant un tube souple, cette chambre communiquant avec la cavité d'échantillonnage par une fente de sortie, caractérisé en ce que la cavité d'échantillonnage (46) est située entre l'extrémité inférieure du tube (1) et la fente de sortie (48).

5

10

15

20

25

30

35

40

45

50

55

60

65

5

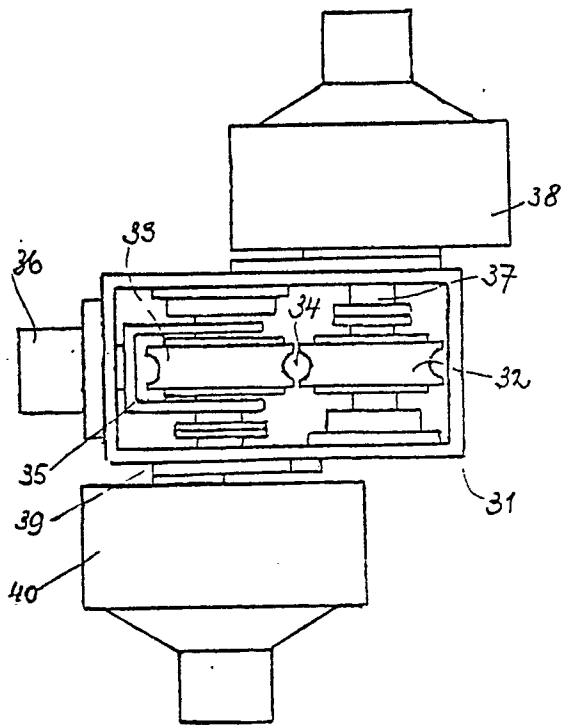

Fig. 1

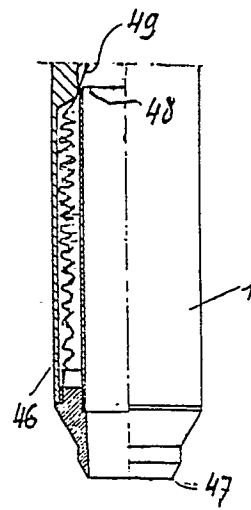

Fig. 3

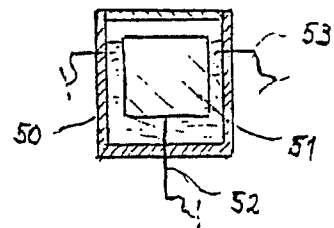

Fig. 4

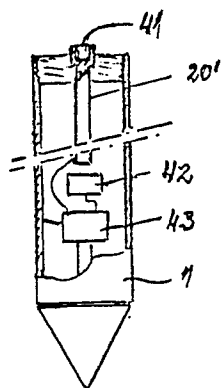

Fig. 2A

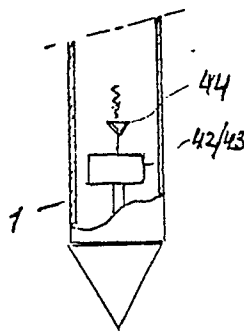

Fig. 2B

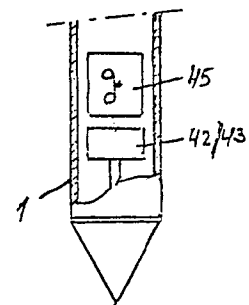

Fig. 2C