

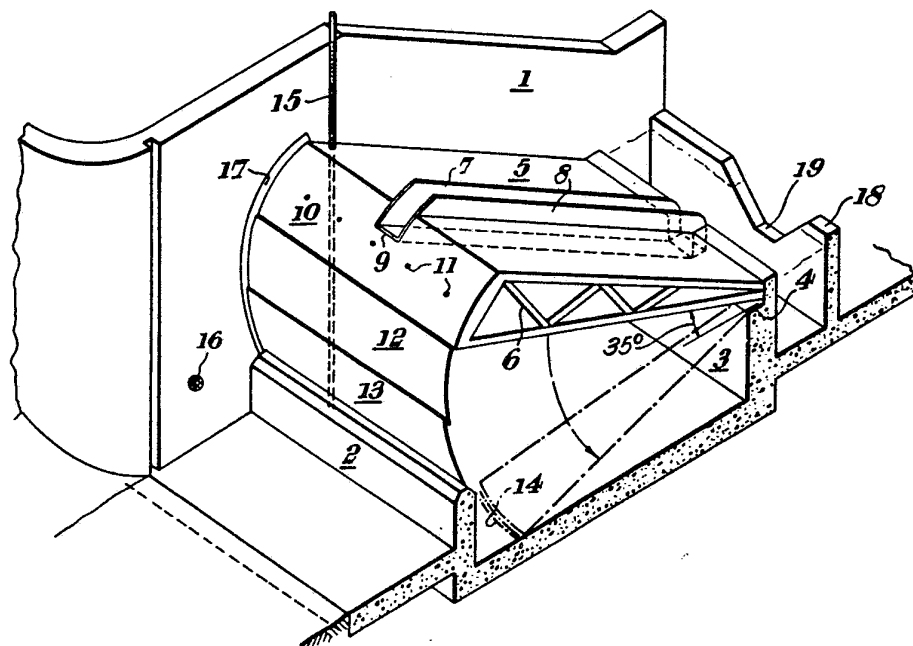

## INTERNATIONAL APPLICATION PUBLISHED UNDER THE PATENT COOPERATION TREATY (PCT)

<p>(51) International Patent Classification<sup>4</sup> : <b>E02B 7/44, 8/08</b></p>	<p><b>A1</b></p>	<p>(11) International Publication Number: <b>WO 85/ 01075</b> (43) International Publication Date: 14 March 1985 (14.03.85)</p>
<p>(21) International Application Number: PCT/GB84/00302 (22) International Filing Date: 30 August 1984 (30.08.84) (31) Priority Application Number: 8323837 (32) Priority Date: 6 September 1983 (06.09.83) (33) Priority Country: GB  (71)(72) Applicant and Inventor: WOOLNOUGH, Anthony, L. [GB/GB]; 6 Lockitt Way, Kingston, Lewes, East Sussex BN7 3LF (GB).  (74) Agent: G.F. REDFERN &amp; COMPANY; Marlborough Lodge, 14 Farncombe Road, Worthing, West Sussex BN11 2BT (GB).  (81) Designated States: AT (European patent), BE (European patent), CH (European patent), DE (European patent), FI, FR (European patent), GB (European patent), JP, LU (European patent), NL (European patent), NO, SE (European patent), US.</p>		<p><b>Published</b> <i>With international search report. Before the expiration of the time limit for amending the claims and to be republished in the event of the receipt of amendments.</i></p>

(54) Title: IMPROVEMENTS IN OR RELATING TO RIVER CONTROL STRUCTURES



## (57) Abstract

River control structures, of the kind known as upstream tilting gates. A structure in accordance with the invention includes a chamber, (1, 2, 3 and 4), and a tilting platform (5). The upstream end of the platform includes a curved transverse wall (10), consisting of a plurality of leaves (12 and 13). When the platform is raised, the leaves provide a continuous wall between the platform and the top of the chamber, while when the platform is lowered, the leaves slide behind each other and are accommodated in the chamber. The structure also includes a channel (7, 8 and 9), extending along the length of the platform. The channel is provided with baffles to limit the flow of water down the channel, to enable fish to surmount the structure.

**FOR THE PURPOSES OF INFORMATION ONLY**

Codes used to identify States party to the PCT on the front pages of pamphlets publishing international applications under the PCT.

AT	Austria	KR	Republic of Korea
AU	Australia	LI	Liechtenstein
BE	Belgium	LK	Sri Lanka
BG	Bulgaria	LU	Luxembourg
BR	Brazil	MC	Monaco
CF	Central African Republic	MG	Madagascar
CG	Congo	MR	Mauritania
CH	Switzerland	MW	Malawi
CM	Cameroon	NL	Netherlands
DE	Germany, Federal Republic of	NO	Norway
DK	Denmark	RO	Romania
FI	Finland	SD	Sudan
FR	France	SE	Sweden
GA	Gabon	SN	Senegal
GB	United Kingdom	SU	Soviet Union
HU	Hungary	TD	Chad
JP	Japan	TG	Togo
KP	Democratic People's Republic of Korea	US	United States of America

## IMPROVEMENTS IN OR RELATING TO RIVER CONTROL STRUCTURES

This invention relates to river control structures. The term "river" is used herein to include any running stream of water and thus extends, for example, to canals and other watercourses, whether natural or artificial.

It is frequently necessary to provide means for controlling the flow of water, for example to provide water storage. Other uses for river control structures include river flow gauging stations and weirs to retain water for irrigation or extraction for public water supply.

One particular type of structure which has been used for river control is known as an "upstream tilting gate." This type of structure includes a longitudinally extending platform, the downstream end of which is supported with freedom to rotate about an axis extending across the river, and the upstream end of which is supported by control means adapted to raise and lower that end.

The above type of control structure is very simple and effective, but it suffers from the disadvantage that material carried downstream by the flowing water collects beneath the platform and eventually prevents the platform from being lowered.

To avoid the problems of blockage and siltation, it has been proposed to provide a depending wall on the upstream edge of the platform. Such a wall is normally in the form of part of a surface of a cylinder, the axis of which is coincident with the axis of rotation of the platform. Such a wall can be designed to prevent material from collecting below the platform, but requires considerable construction work to provide a space below the platform to accommodate the wall as the platform is lowered.

Accordingly it is an object of one aspect of the present invention to provide a river control structure of the general type referred to above, but which does not suffer from the disadvantage of known gates.



From this aspect the invention consists in a river control structure comprising a longitudinally extending platform, one end of which is supported with freedom to rotate about an axis extending across the river, and the other end of which is supported by control means adapted to raise and lower said other end, wherein a plurality of leaves extending across the river depend from said other end of said platform in such a way that, as said other end is lowered towards its lowermost position, successive ones of said leaves slide relative to the respective adjacent leaf so that all said leaves can be accommodated below the platform with their lower edges substantially level, whereas, as said other end is raised, the leaves slide relatively to form a substantially continuous wall across the river.

Preferably a structure in accordance with the invention includes a chamber having an upstream wall, a downstream wall and two side walls. In this case the downstream end of the platform is supported by the downstream wall with freedom to rotate about an axis extending parallel to said downstream wall. The leaves depending from the upstream end of the platform cooperate with the upstream wall of the chamber to control the water flow. When the platform is lowered, all the leaves are accommodated within the chamber with their lower edges substantially on the bottom of the chamber. When the platform is raised, the leaves extend between the upstream edge of the platform and the top of the upstream wall of the chamber.

Whenever a new control structure is provided on a migratory fish river, it is necessary to provide suitable conditions for migrating fish to surmount the structure en route to their spawning beds in the upper reaches of the river. In the past this has been accomplished by separate fish passes, usually flanking the control structure.

It is an object of a second aspect of the present invention to provide an economically and biologically more satisfactory solution to the problem

of enabling fish to surmount a river control structure.

From this second aspect the invention consists in a river control structure comprising a longitudinally extending platform, the downstream end of which is mounted with freedom to rotate about an axis extending across the river, and the other end of which is supported by control means adapted to raise and lower said other end, wherein a baffled channel extends from said one end to said other end of said platform, the baffles being arranged so that, even when said other end of said platform is raised to its maximum height, the water flow down said channel will be not greater than 0.85 metres per second.

A considerable study of the jumping and swimming capabilities of fish, and in particular of sea trout and salmonids, has shown that a baffled channel, designed to restrict water flow to 0.85 metres per second, can be safely negotiated by migrating fish. In the case of sea trout, the design provides a factor of safety greater than 2.

The channel should be designed in such a way that it will contain the turbulent flow caused by the baffles. For this purpose the sides of the channel should extend above the normal water level. These extended side walls will also serve to confine disorientated fish within the channel. Preferably the channel is located substantially on the longitudinal centre line of the platform and normally it will be convenient for the sides of the channel to extend above the upper surface of the platform to approximately the same extent as they descend below it.

The lower end of the channel is preferably designed in such a way as to produce turbulence, which will attract the migrating fish. In addition, or alternatively, an additional downstream wall may be provided with a notch in the centre of the top of the wall to guide the fish towards the lower end of the channel.

The baffles may be arranged in any way which will restrict the flow to



0.85 metres per second at the maximum inclination required. In particular it has been found that an arrangement known as a "Denil type 19 baffle" will restrict flow to this velocity at an inclination of 35 degrees. In fact it would appear that this type of baffle can normally be used safely up to an inclination of 40 degrees.

Preferably the features of the first aspect of the invention are incorporated with the features of the second aspect of the invention.

Thus, according to a third aspect, the invention consists in a river control structure comprising a chamber having an upstream wall, a downstream wall and two side walls, and a longitudinally extending platform, one end of which is supported by said downstream wall with freedom to rotate about a horizontal axis extending parallel to said downstream wall, and the other end of which is supported by control means adapted to raise and lower said other end, wherein a plurality of leaves extending across the width of the chamber depend from said other end of said platform in such a way that, as said other end is lowered towards its lowermost position, successive ones of said leaves slide relative to the respective adjacent leaf so that all said leaves can be accommodated within said chamber with their lower edges substantially on the bottom of the chamber, whereas, as said other end is raised, the leaves slide relatively to one another to form a continuous wall across the chamber between said other end of the platform and the top of the upstream wall, and wherein a baffled channel extends from said one end to said other end of said platform, the baffles being arranged so that, even when said other end of said platform is raised to its maximum height, the water flow down said channel will be not greater than 0.85 metres per second.

Preferably guides are provided in the side walls of the chamber to accommodate the depending leaves. Since the leaves will normally be part-cylindrical, the guides will be arcuate. Preferably seals, possibly made

of rubber or a similar material, will be provided between the sides of the platform and the respective said walls. Preferably holes will be provided in at least some of the leaves to enable water to enter the chamber and thus reduce the weight of the platform to be carried by the control means.

From yet another aspect the invention consists in any features of novelty, taken singly or in combination, of the river control structure illustrated in the accompanying diagrammatic drawing.

The structure illustrated includes a chamber having two side walls, one of which is broken away in the illustration to show the remaining parts of the structure. The other side wall is indicated at 1. The chamber also includes an upstream wall 2 and a downstream wall 3. The downstream wall 3 is provided with a ledge 4 on which the platform 5 rests. The platform illustrated includes an upper flat surface and is given the necessary strength by means of a lattice structure indicated at 6.

A channel having side walls 7 and 8 and a base 9 extends from the upstream end to the downstream end of the platform. As can be seen from the drawing, the side walls 7 and 8 extend approximately the same distance above the upper surface of the platform 5 as they extend below it. Baffles (not shown) are provided in the channel to limit the flow of water down the channel, when the platform is raised to its maximum inclination of 35 degrees, to less than 0.85 metres per second.

The upstream end of the platform includes a curved transverse wall 10. This wall is provided with holes 11 to enable water to enter the interior of the chamber below the platform. Two leaves 12 and 13 depend from the wall 10. As can be seen, when the platform is in its raised position, these leaves provide a continuous wall between the platform and the upper edge of the upstream wall 2. When the platform is lowered, the leaves 12 and 13 slide behind the wall 10 and are accommodated in the chamber as indicated by the dashed lines 14.



Control means are provided to raise and lower the upstream end of the platform 5 and these are indicated diagrammatically as a threaded rod 15, which cooperates with a correspondingly threaded nut secured in the platform. Means (not shown) are provided to rotate the rod 15 to raise and lower the platform. Preferably a detector 16 is provided to measure the water level and give a signal, which may be used for automatic control of the inclination of the platform.

The wall 10 and the leaves 12 and 13 run in arcuate channels in the side walls, the channel in the side wall 1 being shown at 17. Preferably the edges of the platform 5 are provided with rubber seals (not shown) which cooperate with the side walls of the chamber.

To assist the migrating fish to find the entrance to the channel, a wall 18 is provided below the downstream wall 3. This wall has a notch 19 designed to produce turbulence which will guide the fish towards the entrance to the channel.

CLAIMS:

- 1 A river control structure comprising a longitudinally extending platform, one end of which is supported with freedom to rotate about an axis extending across the river, and the other end of which is supported by control means adapted to raise and lower said other end, wherein a plurality of leaves extending across the river depend from said other end of said platform in such a way that, as said other end is lowered towards its lowermost position, successive ones of said leaves slide relative to the respective adjacent leaf so that all said leaves can be accommodated below the platform with their lower edges substantially level, whereas, as said other end is raised, the leaves slide relatively to form a substantially continuous wall across the river.
- 2 A river control structure according to Claim 1, further including a chamber having an upstream wall, a downstream wall and two side walls.
- 3 A river control structure according to Claim 2, wherein the downstream end of the platform is supported by the downstream wall of the chamber, with freedom to rotate about an axis, extending parallel to said downstream wall.
- 4 A river control structure according to Claim 3, wherein the arrangement is such that, when the platform is lowered, all the



leaves are accommodated within the chamber with their lower edges substantially on the bottom of the chamber, whereas, when the platform is raised, the leaves extend between the upstream edge of the platform, and the top of the upstream wall of the chamber.

- 5 A river control structure comprising a longitudinally extending platform, the downstream end of which is mounted with freedom to rotate about an axis extending across the river, and the other end of which is supported by control means adapted to raise and lower said other end of said platform, wherein a baffled channel extends from said one end to said other end of said platform, the baffles being arranged so that, even when said other end of said platform is raised to its maximum height, the water flow down said channel will be not greater than 0.85 metres per second.
- 6 A river control structure according to Claim 5, wherein the sides of the channel extend above the normal water level, so that the channel will contain the turbulent flow caused by the baffles.
- 7 A river control structure according to Claim 5 or Claim 6, wherein the channel is located substantially on the longitudinal centre line of the platform.
- 8 A river control structure according to any of Claims 5 to 7,

wherein the sides of the channel extend above the upper surface of the platform to substantially the same extent as they descend below it.

- 9 A river control structure according to any of Claims 5 to 8, wherein the lower end of the channel is designed in such a way as to produce turbulence.
- 10 A river control structure according to any of Claims 5 to 9, wherein an additional downstream wall is provided, with a notch in the top of the wall, to guide the fish towards the lower end of the channel.
- 11 A river control structure comprising a chamber having an upstream wall, a downstream wall and two side walls, and a longitudinally extending platform, one end of which is supported by said downstream wall with freedom to rotate about a horizontal axis extending parallel to said downstream wall, and the other end of which is supported by control means adapted to raise and lower said other end, wherein a plurality of leaves extending across the width of the chamber depend from said other end of said platform in such a way that, as said other end is lowered towards its lowermost position, successive ones of said leaves slide relative to the respective adjacent leaf so that all said leaves can be accommodated within said chamber with their lower edges substantially on the bottom of the chamber, whereas, as said other end is raised, the leaves slide



relatively to one another to form a continuous wall across the chamber between said other end of the platform and the top of the upstream wall, and wherein a baffled channel extends from said one end to said other end of said platform, the baffles being arranged so that, even when said other end of said platform is raised to its maximum height, the water flow down said channel will be not greater than 0.85 metres per second.

- 12 A river control structure according to Claim 11, wherein arcuate guides are provided in the side walls of the chamber to accommodate the depending leaves.
- 13 A river control structure according to Claim 12, wherein seals are provided between the sides of the platform and the respective side walls.
- 14 A river control structure according to Claim 13, wherein the seals are made of rubber.
- 15 A river control structure according to any of Claims 11 to 14, wherein holes are provided in at least some of the leaves to enable water to enter the chamber, and thus reduce the weight of the platform to be carried by the control means.
- 16 A river control structure substantially as herein before described, with reference to, and as illustrated in, the accompanying diagrammatic drawing.



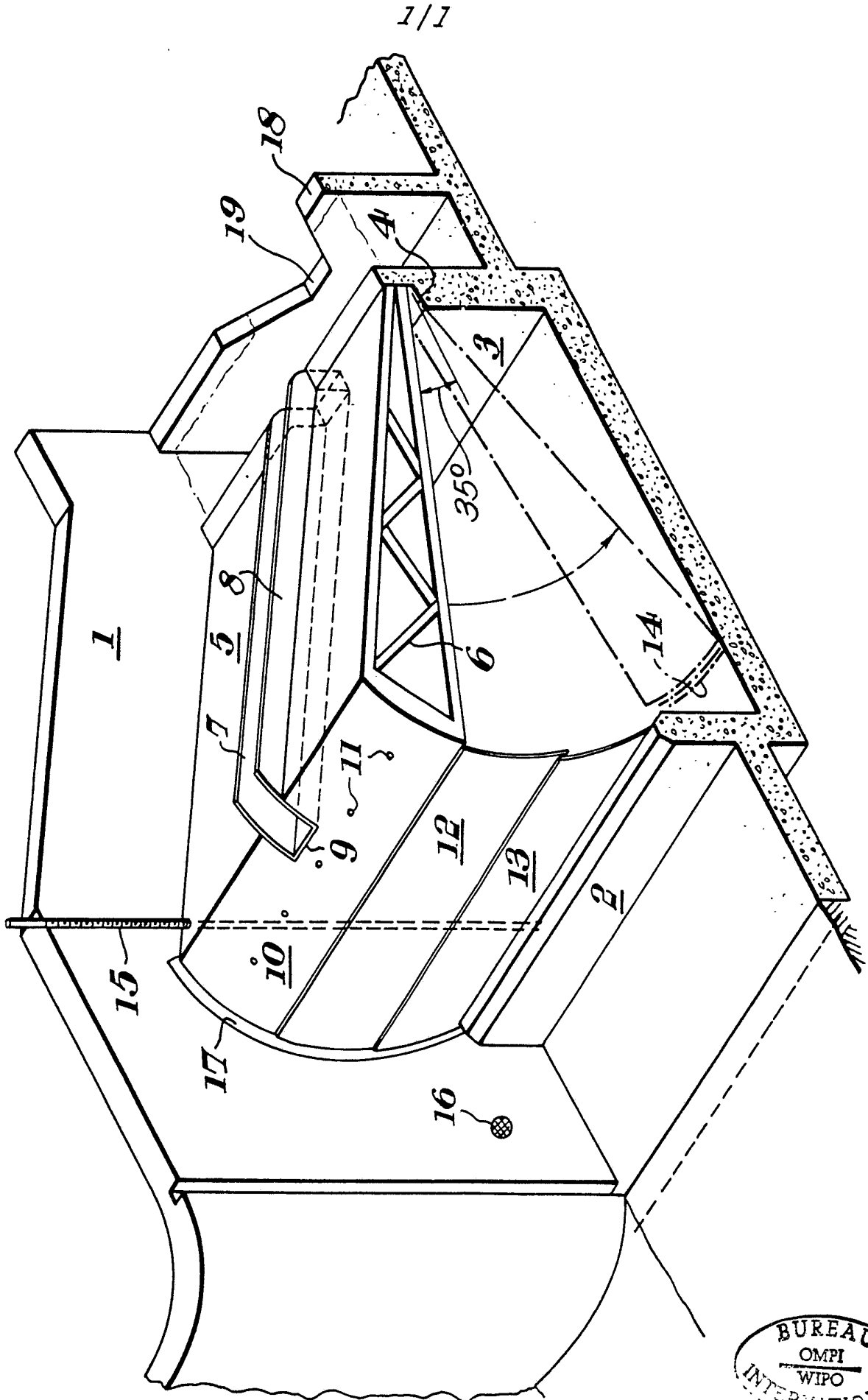

# INTERNATIONAL SEARCH REPORT

International Application No PCT/GB 84/00302

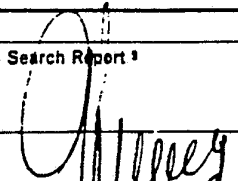
<b>I. CLASSIFICATION OF SUBJECT MATTER</b> (if several classification symbols apply, indicate all) <sup>3</sup>		
According to International Patent Classification (IPC) or to both National Classification and IPC		
IPC <sup>4</sup> : E 02 B 7/44; E 02 B 8/08		
<b>II. FIELDS SEARCHED</b>		
Minimum Documentation Searched <sup>4</sup>		
Classification System	Classification Symbols	
IPC <sup>4</sup>	E 02 B	
Documentation Searched other than Minimum Documentation to the Extent that such Documents are Included in the Fields Searched <sup>5</sup>		
<b>III. DOCUMENTS CONSIDERED TO BE RELEVANT</b> <sup>14</sup>		
Category <sup>6</sup>	Citation of Document, <sup>15</sup> with indication, where appropriate, of the relevant passages <sup>17</sup>	Relevant to Claim No. <sup>18</sup>
Y	GB, A, 1389370 (NEDERHORST) 3 April 1975, see the entire document	1
A	--	2,3,4,11,15
Y	DE, C, 725578 (FISCHER) 13 August 1942, see figure 8	1
A	--	11
A	GB, A, 932 A.D. 1913 (HALL) 12 June 1913, see pages 2-4; figures	1,12
A	DE, B, 1051207 (KLONNE) 19 February 1959, see column 2, lines 17-32; figures 1-3	1,13,14
-----		
<p><sup>6</sup> Special categories of cited documents: <sup>15</sup></p> <p>"A" document defining the general state of the art which is not considered to be of particular relevance</p> <p>"E" earlier document but published on or after the international filing date</p> <p>"L" document which may throw doubts on priority claim(s) or which is cited to establish the publication date of another citation or other special reason (as specified)</p> <p>"O" document referring to an oral disclosure, use, exhibition or other means</p> <p>"P" document published prior to the international filing date but later than the priority date claimed</p> <p>"T" later document published after the international filing date or priority date and not in conflict with the application but cited to understand the principle or theory underlying the invention</p> <p>"X" document of particular relevance; the claimed invention cannot be considered novel or cannot be considered to involve an inventive step</p> <p>"Y" document of particular relevance; the claimed invention cannot be considered to involve an inventive step when the document is combined with one or more other such documents, such combination being obvious to a person skilled in the art.</p> <p>"4" document member of the same patent family</p>		
<b>IV. CERTIFICATION</b>		
Date of the Actual Completion of the International Search <sup>1</sup>	Date of Mailing of this International Search Report <sup>1</sup>	
18th December 1984	31 JAN. 1985	
International Searching Authority <sup>1</sup>	Signature of Authorized Officer <sup>20</sup>	
<b>EUROPEAN PATENT OFFICE</b>	 G.L.M. Kitzberger	

**FURTHER INFORMATION CONTINUED FROM THE SECOND SHEET****V.  OBSERVATIONS WHERE CERTAIN CLAIMS WERE FOUND UNSEARCHABLE <sup>10</sup>**

This international search report has not been established in respect of certain claims under Article 17(2) (a) for the following reasons:

1.  Claim numbers ..... because they relate to subject matter <sup>12</sup> not required to be searched by this Authority, namely:

2.  Claim numbers ..... because they relate to parts of the international application that do not comply with the prescribed requirements to such an extent that no meaningful international search can be carried out <sup>13</sup>, specifically:

**VI.  OBSERVATIONS WHERE UNITY OF INVENTION IS LACKING <sup>11</sup>**

This International Searching Authority found multiple inventions in this international application as follows:

- claims 1-4, 11-16 : Leaves
- claims 5-10 : Baffled channel

1.  As all required additional search fees were timely paid by the applicant, this international search report covers all searchable claims of the international application.

2.  As only some of the required additional search fees were timely paid by the applicant, this international search report covers only those claims of the international application for which fees were paid, specifically claims:

3.  No required additional search fees were timely paid by the applicant. Consequently, this international search report is restricted to the invention first mentioned in the claims; it is covered by claim numbers: 1-4, 11-16.

4.  As all searchable claims could be searched without effort justifying an additional fee, the International Searching Authority did not invite payment of any additional fee.

Remark on Protest

- The additional search fees were accompanied by applicant's protest.
- No protest accompanied the payment of additional search fees.

ANNEX TO THE INTERNATIONAL SEARCH REPORT ON

INTERNATIONAL APPLICATION NO. PCT/GB 84/00302 (SA 7795)

This Annex lists the patent family members relating to the patent documents cited in the above-mentioned international search report. The members are as contained in the European Patent Office EDP file on 18/01/85

The European Patent Office is in no way liable for these particulars which are merely given for the purpose of information.

Patent document cited in search report	Publication date	Patent family member(s)	Publication date
GB-A- 1389370	03/04/75	BE-A- 788408	02/01/73
DE-C- 725578		None	
GB-A- 932		None	
DE-B- 1051207		None	

For more details about this annex :  
see Official Journal of the European Patent Office, No. 12/82