

(19) **DANMARK**

(10) **DK/EP 4137929 T3**



(12) **Oversættelse af
europæisk patentskrift**

Patent- og
Varemærkestyrelsen

-
- (51) Int.Cl.: **G 09 G 5/00 (2006.01)** **G 06 F 3/14 (2006.01)** **G 09 G 5/10 (2006.01)**
H 04 N 19/40 (2014.01)
- (45) Oversættelsen bekendtgjort den: **2024-09-16**
- (80) Dato for Den Europæiske Patentmyndigheds bekendtgørelse om meddelelse af patentet: **2024-08-07**
- (86) Europæisk ansøgning nr.: **22199319.9**
- (86) Europæisk indleveringsdag: **2012-12-06**
- (87) Den europæiske ansøgnings publiceringsdag: **2023-02-22**
- (30) Prioritet: **2011-12-06 US 201161567579 P** **2012-07-23 US 201261674503 P**
2012-09-20 US 201261703449 P
- (62) Stamansøgningsnr: **20203810.5**
- (84) Designerede stater: **AL AT BE BG CH CY CZ DE DK EE ES FI FR GB GR HR HU IE IS IT LI LT LU LV MC MK MT NL NO PL PT RO RS SE SI SK SM TR**
- (73) Patenthaver: **Dolby Laboratories Licensing Corporation, 1275 Market Street, San Francisco, CA 94103, USA**
- (72) Opfinder: **Miller, Jon Scott, , Burbank 91505-5300, USA**
Daly, Scott, , San Francisco 94103, USA
Nezamabadi, Mahdi, , Moorestown 08057, USA
Atkins, Robin, , Sunnyvale 94085-4703, USA
- (74) Fuldmægtig i Danmark: **Plougmann Vingtoft A/S, Strandvejen 70, 2900 Hellerup, Danmark**
- (54) Benævnelse: **FREMGANGSMÅDE TIL AT FORBEDRE DEN PERCEPTUELLE LUMINANS IKKE-LINEÆRITETSBASEREDE BILLEDDATAUDVEKLSLING OVER FORSKELLIGE DISPLAYEGENSKABER**
- (56) Fremdragne publikationer:
EP-A1- 1 391 865
WO-A1-2007/014681

DESCRIPTION

Description

CROSS-REFERENCE TO RELATED APPLICATIONS

[0001] This application claims priority to U.S. Provisional Patent Application No. 61/567,579 filed 6 December 2011; U.S. Provisional Patent Application No. 61/674,503 filed 23 July 2012; and U.S. Provisional Patent Application No. 61/703,449 filed 20 September 2012.

[0002] This application is a European divisional application of European patent application EP 20203810.5 (reference: D11082EP05), for which EPO Form 1001 was filed 26 October 2020.

TECHNOLOGY OF THE INVENTION

[0003] The present invention relates generally to image data. More particularly, an embodiment of the present invention relates to perceptual nonlinearity-based image data exchange across different display capabilities.

BACKGROUND OF THE INVENTION

[0004] Advances in technology allow modern display designs to render image and video content with significant improvements in various quality characteristics over the same content, as rendered on less modern displays. For example, some more modern displays are capable of rendering content with a dynamic range (DR) that is higher than the standard dynamic range (SDR) of conventional or standard displays.

[0005] For example, some modern liquid crystal displays (LCDs) have a light unit (a backlight unit, a side light unit, etc.) that provides a light field in which individual portions may be modulated separately from modulation of the liquid crystal alignment states of the active LCD elements. This dual modulation approach is extensible (e.g., to N-modulation layers wherein N comprises an integer greater than two), such as with controllable intervening layers (e.g., multiple layers of individually controllable LCD layers) in an electro-optical configuration of a display.

[0006] In contrast, some existing displays have a significantly narrower dynamic range (DR) than high dynamic range (HDR). Mobile devices, computer pads, game devices, television (TV)

and computer monitor apparatus that use typical cathode ray tube (CRT), liquid crystal display (LCD) with constant fluorescent white back lighting or plasma screen technology may be constrained in their DR rendering capability to approximately three orders of magnitude. Such existing displays thus typify a standard dynamic range (SDR), sometimes also referred to as "low dynamic range" or "LDR," in relation to HDR.

[0007] Images captured by HDR cameras may have a scene-referred HDR that is significantly greater than dynamic ranges of most if not all display devices. Scene-referred HDR images may comprise large amounts of data, and may be converted into post-production formats (e.g., HDMI video signals with 8 bit RGB, YCbCr, or deep color options; 1.5 Gbps SDI video signals with a 10 bit 4:2:2 sampling rate; 3 Gbps SDI with a 12 bit 4:4:4 or 10 bit 4:2:2 sampling rate; and other video or image formats) for facilitating transmission and storage. Post-production images may comprise a much smaller dynamic range than that of scene-referred HDR images. Furthermore, as images are delivered to end users' display devices for rendering, device-specific and/or manufacturer-specific image transformations occur along the way, causing large amounts of visually noticeable errors in rendered images in comparison with the original scene-referred HDR images.

[0008] WO 2007/014681 A1 describes a method to calibrate a display system such that the display system is conforming to an enforced standard for a wider range of parameters, e.g. viewing angles, than compared to traditional calibration methods. This is obtained by calculating an optimised set of calibration parameters for the display to be conform to the enforced standard for the selected range of parameters.

[0009] EP 1 391 865 A1 describes a device and method for processing video picture data for display on a display device having a plurality of luminous elements corresponding to pixels of a video picture, wherein the brightness of each pixel is controlled by sub-field code words corresponding to a number of impulses for switching on and off the luminous elements, by dithering said video picture data and sub-field coding the dithered video picture data for displaying. The brightness values of the video picture data are mapped to brightness levels taking the human contrast sensitivity into account and are based on the Weber-Fechner-law.

[0010] The approaches described in this section are approaches that could be pursued, but not necessarily approaches that have been previously conceived or pursued. Therefore, unless otherwise indicated, it should not be assumed that any of the approaches described in this section qualify as prior art merely by virtue of their inclusion in this section. Similarly, issues identified with respect to one or more approaches should not assume to have been recognized in any prior art on the basis of this section, unless otherwise indicated.

SUMMARY OF THE INVENTION

[0011] The invention is defined by the independent claims. Specific embodiments are defined by the dependent claims.

BRIEF DESCRIPTION OF THE DRAWINGS

[0012] The present invention is illustrated by way of example, and not by way of limitation, in the figures of the accompanying drawings and in which like reference numerals refer to similar elements and in which:

FIG. 1 illustrates an example family of contrast sensitivity function curves that span across a plurality of light adaptation levels, according to an example embodiment of the present invention;

FIG. 2 illustrates an example integration path, according to an example embodiment of the present invention;

FIG. 3 illustrates an example gray scale display function, in accordance with an example embodiment of the present invention;

FIG. 4 illustrates a curve depicting Weber fractions, according to an example embodiment of the present invention;

FIG. 5 illustrates an example framework of exchange image data with devices of different GSDFs, according to an example embodiment of the present invention;

FIG. 6 illustrates an example conversion unit, according to an example embodiment of the present invention;

FIG. 7 illustrate an example SDR display, according to an example embodiment of the present invention;

FIG. 8A and FIG. 8B illustrate example process flows, according to an example embodiment of the present invention;

FIG. 9 illustrates an example hardware platform on which a computer or a computing device as described herein may be implemented, according an example embodiment of the present invention;

FIG. 10A illustrates maximums for code errors in units of JNDs in a plurality of code spaces each with a different one of one of one or more different bit lengths, according to some example embodiments;

FIG. 10B through FIG. 10E illustrate distributions of code errors, according to some example embodiments; and

FIG. 11 illustrates values of parameters in a functional model, according to an example embodiment.

DESCRIPTION OF EXAMPLE EMBODIMENTS

[0013] Example embodiments, which relate to perceptual luminance nonlinearity-based image data exchange across displays of different capabilities, are described herein. In the following description, for the purposes of explanation, numerous specific details are set forth in order to provide a thorough understanding of the present invention. It will be apparent, however, that the present invention may be practiced without these specific details. In other instances, well-known structures and devices are not described in exhaustive detail, in order to avoid unnecessarily occluding, obscuring, or obfuscating the present invention.

[0014] Example embodiments are described herein according to the following outline:

1. 1. GENERAL OVERVIEW
2. 2. CONTRAST SENSITIVITY FUNCTION (CSF) MODEL
3. 3. PERCEPTUAL NONLINEARITY
4. 4. DIGITAL CODE VALUES AND GRAY LEVELS
5. 5. MODEL PARAMETERS
6. 6. VARIABLE SPATIAL FREQUENCIES
7. 7. FUNCTIONAL MODELS
8. 8. EXCHANGE IMAGE DATA BASED ON REFERENCE GSDF
9. 9. CONVERTING REFERENCE ENCODED IMAGE DATA
10. 10. EXAMPLE PROCESS FLOWS
11. 11. IMPLEMENTATION MECHANISMS - HARDWARE OVERVIEW

1. GENERAL OVERVIEW

[0015] This overview presents a basic description of some aspects of an embodiment of the present invention. It should be noted that this overview is not an extensive or exhaustive summary of aspects of the embodiment. Moreover, it should be noted that this overview is not intended to be understood as identifying any particularly significant aspects or elements of the embodiment, nor as delineating any scope of the embodiment in particular, nor the invention in general. This overview merely presents some concepts that relate to the example embodiment in a condensed and simplified format, and should be understood as merely a conceptual prelude to a more detailed description of example embodiments that follows below.

[0016] Human vision may not perceive a difference between two luminance values if the two luminance values are not sufficiently different from each other. Instead, human vision only perceives a difference if the luminance value differ no less than a just noticeable difference (JND). Due to perceptual nonlinearity of human vision, the amounts of individual JNDs are not

uniformly sized or scaled across a range of light levels, but rather vary with different individual light levels. In addition, due to the perceptual nonlinearity, the amounts of individual JNDs are not uniformly sized or scaled across a range of spatial frequencies at a particular light level, but rather vary with different spatial frequencies below a cut-off spatial frequency.

[0017] Encoded image data with luminance quantization steps of equal sizes or linearly scaled sizes does not match with perceptual nonlinearity of human vision. Encoded image data with luminance quantization steps at a fixed spatial frequency also does not match with perceptual nonlinearity of human vision. Under these techniques, when code words are assigned to represent quantized luminance values, too many code words may be distributed in a particular region (e.g., the bright region) of the range of light levels, while too few code words may be distributed in a different region (e.g., the dark region) of the range of light levels.

[0018] In the overpopulated region, a multitude of code words may not produce perceptual differences, and are, for all practical purposes, therefore wasted. In the underpopulated region, two adjacent code words may produce a perceptual difference much greater than a JND, and possibly produces contour distortion (also known as banding) visual artifacts.

[0019] Under techniques as described herein, a contrast sensitivity function (CSF) model may be used to determine JNDs across a wide range (e.g., 0 to 12,000 cd/m²) of light levels. In an example embodiment, the peak JND as a function of spatial frequency at a particular light level is selected to represent a quantum of human perception at the particular light level. The selection of peak JNDs is in accord with the behaviors of human vision that adapts to a heightened level of visual perceptibility when a background of close but different luminance values is being viewed, which is sometimes referred to in video and image display fields as a crispening effect and/or Whittle's Crispening effect and may be described herein as such. As used herein, the term "a light adaption level" may be used to refer to a light level at which a (e.g., peak) JND is selected/determined, assuming that human vision is adapted to the light level. Peak JNDs as described herein vary over spatial frequency at different light adaptation levels.

[0020] As used herein, the term "spatial frequency" may refer to a rate of spatial modulation/variation in images (wherein rate is computed in relation to or over spatial distance, in contrast to computing rate in relation to time). In contrast to conventional approaches that may fix spatial frequency at a specific value, the spatial frequency as described herein may vary, for example, in or over a range. In some embodiments, peak JNDs may be limited within a particular spatial frequency range (e.g., 0.1 to 5.0, 0.01 to 8.0 cycles/degrees, or a smaller or larger range).

[0021] A reference gray scale display function (GSDF) may be generated based on the CSF model. In some embodiments, a very wide field of view is assumed for the CSF model for generating a reference GSDF that better support entertainment display fields. The GSDF refers to a set of reference digital code values (or reference code words), a set of reference gray levels (or reference luminance values), and a mapping between the two sets. In an

example embodiment, each reference digital code value corresponds to a quantum of human perception, as represented by a JND (e.g., a peak JND at a light adaptation level). In an example embodiment, an equal number of reference digital code values may correspond to a quantum of human perception.

[0022] The GSDF may be obtained by accumulating JNDs from an initial value. In an example embodiment, a middle code word value (e.g., 2048 for a 12-bit code space) is given as an initial value to a reference digital code. The initial value of the reference digital code may correspond to an initial reference gray level (e.g., 100 cd/m²). Other reference gray levels for other values of the reference digital code may be obtained by positively accumulating (adding) JNDs as the reference digital code is incremented one by one, and by negatively accumulating (subtracting) JNDs as the reference digital code is decremented one by one. In an example embodiment, quantities such as contrast thresholds may be used in computing reference values in the GSDF, in place of JNDs. These quantities actually used in computation of a GSDF may be defined as unitless ratios and may differ from corresponding JNDs only by known or determinable multipliers, dividing factors and/or offsets.

[0023] A code space may be selected to include all reference digital code values in the GSDF. In some embodiments, the code space in which all the reference digital code values reside may be one of a 10-bit code space, an 11-bit code space, a 12-bit code space, a 13-bit code space, a 14-bit code space, a 15-bit code space, or a larger or smaller code space.

[0024] While a large code space (>15 bits) may be used to host all reference digital code values, in a particular embodiment, the most efficient code space (e.g., 10 bits, 12 bits, etc.) is used to host all reference digital code values generated in a reference GSDF.

[0025] The reference GSDF may be used to encode image data, for example, captured or generated by HDR cameras, studio systems, or other systems with a scene-referred HDR that is significantly greater than dynamic ranges of most if not all display devices. The encoded image data may be provided to downstream devices in a wide variety of distribution or transmission methods (e.g., HDMI video signals with 8 bit RGB, YCbCr, or deep color options; 1.5 Gbps SDI video signals with a 10 bit 4:2:2 sampling rate; 3 Gbps SDI with a 12 bit 4:4:4 or 10 bit 4:2:2 sampling rate; and other video or image formats).

[0026] In some embodiments, because adjacent reference digital code values in the reference GSDF correspond to gray levels that are within a JND, details for which human vision is capable of distinguishing may be completely or substantially preserved in the image data encoded based on the reference GSDF. A display that fully supports the reference GSDF may possibly render images with no banding or contour distortion artifacts.

[0027] Image data encoded based on the reference GSDF (or reference encoded image data) may be used to support a wide variety of less capable displays that may not fully support all reference luminance values in the reference GSDF. Because the reference encoded image data comprises all the perceptual details in the supported luminance range (which may be

designed to be a superset of what displays support), reference digital code values may be optimally and efficiently transcoded to display-specific digital code values in a way to preserve as much details as a specific display is capable of supporting and to cause as few visually noticeable errors as possible. Additionally and/or optionally, decontouring and dithering may be performed in conjunction with, or as a part of, transcoding from reference digital code values to display-specific digital code values to further improve image or video quality.

[0028] Techniques as described herein are not color-space dependent. They may be used in a RGB color space, a YCbCr color space, or a different color space. Furthermore, techniques that derive reference values (e.g., reference digital code values and reference gray levels) using JNDs which vary with spatial frequency may be applied to a different channel (e.g., one of red, green, and blue channels) other than a luminance channel in a different color space (e.g., RGB) which may or may not comprise a luminance channel. For example, reference blue values may be derived in place of reference gray levels using JNDs which are applicable to the blue color channel. Thus, in some embodiments, gray scale may be substituted for color. Additionally and/or optionally, different CSF models may also be used instead of Barten's model. So may different model parameters be used for the same CSF model.

[0029] In some embodiments, mechanisms as described herein form a part of a media processing system, including, but not limited to: a handheld device, game machine, television, laptop computer, netbook computer, cellular radiotelephone, electronic book reader, point of sale terminal, desktop computer, computer workstation, computer kiosk, or various other kinds of terminals and media processing units.

[0030] Various modifications to the preferred embodiments and the generic principles and features described herein will be readily apparent to those skilled in the art. Thus, the disclosure is not intended to be limited to the embodiments shown, but is to be accorded the widest scope consistent with the principles and features described herein.

2. CONTRAST SENSITIVITY FUNCTION (CSF) MODEL

[0031] Human visual sensitivity for spatial structures in rendered images may be best described with contrast sensitivity functions (CSFs), which describe contrast sensitivity as functions of spatial frequency (or rate of spatial modulation/variation in images as perceived by a human observer). As used herein, contrast sensitivity, S , may be considered as a gain in human visual neural signal processing, while contrast thresholds, C_T , may be determined from the inverse of the contrast sensitivity, for example:

$$\text{Contrast-Sensitivity} = S = 1/C_T \quad \text{expression (1)}$$

[0032] As used herein, the term "contrast threshold" may refer to, or relate to, a lowest value (e.g., a just-noticeable difference) of (relative) contrast necessary for human eyes to perceive a difference in contrast; in some embodiments, contrast thresholds may also be depicted as a

function of the just-noticeable difference divided by the light adaptation level across a range of luminance values.

[0033] In some embodiments, contrast thresholds may be directly measured in experiments, without use of any CSF model. In some other embodiments, however, contrast thresholds may be determined based on a CSF model. A CSF model may be built with a number of model parameters and may be used to derive a GSDF whose quantization steps in gray levels depend on and vary with light levels characterized by luminance values and spatial frequency. An example embodiment may be implemented based on one or more of a variety of CSF models such as those described in Peter G. J. Barten, Contrast Sensitivity of the Human Eye and its Effects on Image Quality (1999) (herein after Barten's model or Barten's CSF model), or Scott Daly, Chapter 17 in Digital Images and Human Vision, ed., by A. B. Watson, MIT Press (1993) (hereinafter Daly's model). In relation to example embodiments of the present invention, contrast thresholds used to generate a reference grayscale display function (GSDF) may be derived experimentally, theoretically, with a CSF model, or a combination thereof.

[0034] As used herein, a GSDF may refer to a mapping of a plurality of digital code values (e.g., 1, 2, 3, ... , N) to a plurality of gray levels ($L_1, L_2, L_3, \dots, L_N$), in which the digital code values represent index values of contrast thresholds and the gray levels correspond to the contrast thresholds, as shown in TABLE 1.

TABLE 1

Digital Code Value	Gray Level (Luminance Value)
1	L_1
2	L_2
3	L_3
...	...
$i-1$	L_{i-1}
i	L_i
$i+1$	L_{i+1}
...	...
N	L_N

[0035] In an embodiment, a gray level (e.g., L_i) corresponding to a digital code value (e.g., i) and an adjacent gray level (e.g., L_{i+1}) may be computed in relation to a contrast (e.g., $C(i)$) as follows:

$$\begin{aligned}
 C(i) &= (L_{i-1} - L_i) / (L_{i+1} + L_i) \\
 &= (L_{i-1} - L_{\text{mean}(i, i+1)}) / L_{\text{mean}(i, i+1)} \\
 &\approx \frac{1}{2} \Delta L / L \qquad \text{expression (2)}
 \end{aligned}$$

wherein $C(i)$ represents a contrast for a luminance range that is bounded between L_i and L_{i+1} .

$L_{\text{mean}}(i, i+1)$ comprise an arithmetic average or mean of the two adjacent gray levels L_i and L_{i+1} . The contrast $C(i)$ is arithmetically related to a Weber fraction $\Delta L/L$ by a factor of two. Here, ΔL represents $(L_{i+1} - L_i)$, and L represents one of L_i , L_{i+1} , or an intermediate value between L_i and L_{i+1} .

[0036] In some embodiments, a GSDF generator may set the contrast $C(i)$ to a value equal, or otherwise proportional, to a contrast threshold (e.g., $C_T(i)$) at a luminance level L between L_i and L_{i+1} , inclusive, as follows:

$$C(i) = k C_T(i) \quad \text{expression (3)}$$

wherein k represents a multiplicative constant. In relation to embodiments of the present invention, other descriptive statistics/definitions (e.g., geometric mean, median, mode, variance, or standard deviation) and/or scaling ($\times 2$, $\times 3$, divided or multiplied by a scaling factor, etc.) and/or offsetting (+1, +2, -1, -2, subtracted or added by an offset, etc.) and/or weighting (e.g., assigning the two adjacent gray levels with the same or different weight factors) may be used to relate contrast thresholds with contrasts for the purpose of computing gray levels in a GSDF.

[0037] As computed in expressions (1), (2) and (3), contrasts or contrast thresholds may comprise a relative value, and may thus comprise a unitless quantity (e.g., so S may also be unitless).

[0038] A CSF model may be built up from basic contrast threshold measurements or computations based on a CSF that depicts the CSF model. Human vision is unfortunately complex, adaptive and nonlinear, so that there is no single CSF curve that describes the human vision. Instead, a family of CSF curves may be generated based on a CSF model. Even with the same CSF model, different values of model parameters produce different plots for the family of CSF curves.

3. PERCEPTUAL NONLINEARITY

[0039] FIG. 1 illustrates an example family of CSF curves that span across a plurality of light adaptation levels. For the purpose of illustration only, the highest CSF curve depicted in FIG. 1 is for a light adaptation level at a luminance value of 1000 candelas per square meter (cd/m^2 or 'nits'), and the other decreasing height curves are for light adaptation levels at decreasing luminance values with successive factors of 10 reductions. Notable features readable from the CSF curves are that with increasing luminance (increasing light adaptation levels), the overall contrast sensitivity including the maximum (or peak) contrast sensitivity increases. The peak spatial frequency at which the contrast sensitivity peaks on the CSF curves in FIG. 1 shifts to higher spatial frequencies. Similarly, the max perceptible spatial frequency (cut-off frequency) on the CSF curves, which is the interception of the CSF curves with the horizontal (spatial frequency) axis, also increases.

[0040] In an example embodiment, a CSF function that gives rise to a family of CSF curves as illustrated in FIG. 1 may be derived with the Barten's CSF model, which takes into account a number of key effects relating to human perception. An example CSF, $S(u)$, (or the inverse of the corresponding contrast threshold, m_t) under the Barten's CSF model may be computed as shown in Expression (4), below.

$$S(u) = \frac{1}{m_t} = \frac{M_{opt}(u)/k}{\sqrt{T \left(\frac{1}{X_0^2} + \frac{1}{X_{max}^2} + \frac{u^2}{N_{max}^2} \right) \left(\frac{1}{\eta \rho E} + \frac{\Phi_0}{1 - e^{-(u/u_0)^2}} \right)}} \quad \text{expression (4)}$$

The example model parameters used in expression (4) above comprise the representations listed below:

- 2 (the numeric factor) corresponds to binocular vision (4 if monocular);
- k represents a signal/noise ratio, for example, 3.0;
- T represents an integration time of the eye, for example, 0.1 second;
- X_0 represents an angular size of object (e.g., in a square shape);
- X_{max} represents a maximum angular size of the integration area of the eye (e.g., 12degrees);
- N_{max} represents a maximum number of cycles that are accumulated via probability summation, e.g., 15 cycles;
- η represents a quantum efficiency of the eye, e.g., .03;
- ρ represents a photon conversion factor;
- E represents a retinal illuminance, for example, in Troland units;
- Φ_0 represents a spectral density of neural noise, e.g., 3×10^{-8} second * degrees²; and
- u_0 represents a maximum spatial frequency for lateral inhibition, e.g., 7 cycles/degrees.

The optical modulation transfer function, M_{opt} , may be given as follows:

$$= e^{-2\pi^2 \sigma^2 u^2} \quad \text{expression (5)}$$

where σ represents a model parameter related to pupil and/or light level.

[0041] Barten's CSF model as discussed above may be used to describe perceptual nonlinearity relative to luminance. Other CSF models may also be used to describe perceptual nonlinearity. For example, Barten's CSF model does not account for the effect of accommodation, which causes a lowering of the cut-off spatial frequency in the high spatial frequency region of the CSF. This lowering effect due to accommodation may be expressed as a function of decreasing viewing distance.

[0042] For example, for viewing distances over 1.5 meters, the maximum cutoff spatial frequency as depicted by Barten's CSF model may be achieved, without affecting the effectiveness of Barten's model as an appropriate model to describe perceptual nonlinearity. However, for distances less than 1.5 meters, the effect of accommodation starts to become significant, reducing the accuracy of Barten's model.

[0043] Thus, for tablet displays, which have closer viewing distances, such as 0.5 meter, and smartphones, which can have viewing distances as close as 0.125 meter, Barten's CSF model may not be optimally tuned.

[0044] In some embodiments, Daly's CSF model, which takes into account the accommodation effect, may be used. In a particular embodiment, Daly's CSF model may be constructed in part based on Barten's CSF, $S(u)$, in expression (4) above, for example, by modifying the optical modulation transfer function, M_{opt} , in expression (5).

4. DIGITAL CODE VALUES AND GRAY LEVELS

[0045] A GSDF as illustrated in TABLE 1 maps perceptual nonlinearity using the digital code values to represent gray levels tied to contrast thresholds in human vision. The gray levels which comprise all the mapped luminance values may be distributed in such a way that they are optimally spaced to match the perceptual nonlinearity of human vision.

[0046] In some embodiments, when the maximum number of gray levels in a GSDF are sufficiently large relative to the maximum range of luminance values, digital code values in the GSDF may be used in a way to achieve the lowest number (e.g., below a total of 4096 digital code values) of gray levels without causing the visibility of the gray level step transition (e.g., visible as a false contour or band in an image; or a color shift in dark regions of an image).

[0047] In some other embodiments, a limited number of digital code values may still be used to represent a wide dynamic range of gray levels. For example, when the maximum number of grayscale levels in a GSDF are not sufficiently large relative to the maximum range of the grayscale levels (e.g., digital code values in an 8-bit representation with the range of grayscale levels from 0 to 12,000 nits), the GSDF may still be used in a way to achieve the lowest number (e.g., below a total of 256 digital code values) of gray levels to reduce or minimize the visibility of the gray level step transition. With such a GSDF, amounts/degrees of perceptible errors/artifacts of the step transition may be evenly distributed throughout the hierarchy of a relatively low number of gray levels in the GSDF. As used herein, the term "grayscale level" or "gray level" may be used interchangeably, and may refer to a represented luminance value (a quantized luminance value represented in a GSDF).

[0048] Gray levels in a GSDF may be derived by stacking or integrating contrast thresholds across light adaptation levels (at different luminance values). In some embodiments, quantization steps between gray levels may be so chosen that a quantization step between

any two adjacent gray levels lands within a JND. A contrast threshold at a particular light adaptation level (or luminance value) may be no more than the just-noticeable difference (JND) at that particular adaptation level. Gray levels may be derived by integrating or stacking fractions of contrast thresholds (or JNDs). In some embodiments, the number of digital code values is more than sufficient to represent all the JNDs in the represented dynamic range of luminance.

[0049] Contrast thresholds, or inversely contrast sensitivities, that are used to compute grayscale levels may be selected from a CSF curve at a different spatial frequency other than a fixed spatial frequency for a particular light adaptation level (or luminance value). In some embodiments, each of the contrast thresholds is selected from a CSF curve at a spatial frequency that corresponds to a peak contrast sensitivity (e.g., due to Whittle's crispening effect) for a light adaptation level. In addition, contrast thresholds may be selected from CSF curves at different spatial frequencies for different light adaptation levels.

[0050] An example expression to compute/stack the gray levels in the GSDF is as follows:

$$GSDF = \left(\sum_{L_{min}} JND \right) \quad \text{expression (6)}$$

$$JND = 1/S(f, L_A)$$

where f represents the spatial frequency, which may be other than a fixed number under techniques as described herein; and L_A represents the light adaptation level. L_{min} may be the lowest luminance value in all the mapped gray levels. As used herein, the term "Nit" or its abbreviation "nt" may relate or refer, synonymously or interchangeably, to a unit of image intensity, brightness, luma and/or luminance that is equivalent or equal to one (1) candela per square meter ($1 \text{ Nit} = 1 \text{ nt} = 1 \text{ cd/m}^2$). In some embodiments, L_{min} may comprise a value of zero. In some other embodiments, L_{min} may comprise a non-zero value (e.g., a certain dark black level, 10^{-5} nit, 10^{-7} nit, etc., which may be lower than what display devices are generally able to achieve). In some embodiments, L_{min} may be replaced with other than a minimum initial value, such as an intermediate value, or a maximum value, which allows stacking computations with subtraction or negative addition.

[0051] In some embodiments, stacking of the JNDs to derive gray levels in a GSDF is performed by summation, for example, as shown in expression (6). In some other embodiments, an integral may be used in place of the discrete summation. The integral may integrate along an integration path determined from a CSF (e.g., expression (4)). For example, the integration path may comprise peak contrast sensitivities (e.g., different peak sensitivities corresponding to different spatial frequencies) for all light adaptation levels in a (reference) dynamic range for the CSF.

[0052] As used herein, an integration path may refer to a visible dynamic range (VDR) curve used to represent human perceptual nonlinearity and to establish a mapping between a set of digital code values and a set of reference gray levels (quantized luminance values). The mapping may be required to meet the criteria that each quantization step (e.g., the luminance

difference of two adjacent gray levels in TABLE 1) be less than the JNDs above or below a corresponding light adaptation level (luminance value). The instantaneous derivative (in units of nit/spatial-cycle) of the integration path at a particular light adaptation level (luminance value) is proportional to the JND at the particular adaptation level. As used herein, the term "VDR" or "visual dynamic range" may refer a dynamic range wider than a standard dynamic range, and may include, but is not limited to, a wide dynamic range up to the instantaneously perceivable dynamic range and color gamut which human vision can perceive at an instant.

[0053] Based on techniques as described herein, a reference GSDF that is independent of any specific displays or image processing devices may be developed. In some embodiments, one or more model parameters other than light adaptation level (luminance), spatial frequency, and angular size may be set to constant (or fixed) values.

5. MODEL PARAMETERS

[0054] In some embodiments, the CSF model is constructed with conservative model parameter values that cover a broad range of display devices. The use of the conservative model parameter values provides smaller JNDs than existing standard GSDFs. Accordingly, in some embodiments, the reference GSDF under the techniques described herein is capable of supporting luminance values with a high precision that exceeds the requirements of these display devices.

[0055] In some embodiments, model parameters as described herein include a field-of-vision (FOV) parameter. The FOV parameter may be set to a value of 45 degrees, 40 degrees, 35 degrees, 30 degrees, 25 degrees, or another larger or smaller value that supports a wide range of display devices and viewing scenarios including those used in studios, theaters or high-end entertainment systems.

[0056] Model parameters as described herein may include an angular size parameter, which may relate for example to a field of view. The angular size parameter may be set to a value of 45 degrees × 45 degrees, 40 degrees × 40 degrees, 35 degrees × 35 degrees, 30 degrees × 30 degrees, 25 degrees × 25 degrees, or another larger or smaller value that supports a wide range of display devices and viewing scenarios. In some embodiments, the angular size parameter used in part to derive the reference GSDF is set to n degrees × m degrees, where either of n and m may be a numeric value between 30 and 40, and n and m may or may not be equal.

[0057] In some embodiments, a larger angular size (e.g., 40 degrees × 40 degrees) is used to produce a reference GSDF with a greater number of grayscale levels and thus more contrast sensitivity. The GSDF may be used to support a wide range of viewing and/or displaying scenarios (e.g., large screen video displays) which may require a wide viewing angle of ~30 to 40 degrees. The GSDF having an increased sensitivity due to the selection of large angular size may also be used to support highly variable viewing and/or displaying scenarios (e.g.,

cinemas). It is possible to select even larger angular sizes; however, raising the angular size significantly above a certain angular size (e.g., 40 degrees) may produce relatively limited marginal benefits.

[0058] In some embodiments, a reference GSDF model covers a large luminance range. For example, gray levels, or quantized luminance values, that are represented by the reference GSDF model ranges from 0 or approximately 0 (e.g., 10^{-7} cd/m²) to 12,000 cd/m². The lower bound of the represented luminance values in the reference GSDF model may be 10^{-7} cd/m², or a lower or higher value (e.g., 0, 10^{-5} , 10^{-8} , 10^{-9} cd/m², etc.). The GSDF may be used to support a wide range of viewing and/or displaying scenarios with different ambient light levels. The GSDF may be used to support a wide range of display devices with different dark black levels (in theaters, indoor, or outdoor).

[0059] The upper bound of the represented luminance values in the reference GSDF model may be 12,000 cd/m², or a lower or higher value (e.g., 6000-8000, 8000-10000, 10000-12000, 12000-15000 cd/m², etc.). The GSDF may be used to support a wide range of viewing and/or displaying scenarios with high dynamic ranges. The GSDF may be used to support a wide range of display devices with different maximum luminance levels (HDR TVs, SDR displays, laptops, tablets, handheld devices, etc.).

6. VARIABLE SPATIAL FREQUENCIES

[0060] FIG. 2 illustrates an example integration path (denoted as VDR) that may be used as an integration path for obtaining gray levels in a reference GSDF as described herein, in accordance with an example embodiment of the present invention. In embodiments, the VDR curve is used to accurately capture the peak contrast sensitivity of human vision over a high dynamic range of luminance values.

[0061] As illustrated in FIG. 2, peak contrast sensitivities do not occur at a fixed spatial frequency value, but rather occur at smaller spatial frequencies as light adaptation levels (luminance values) drop. This means that techniques (e.g., DICOM) with a fixed spatial frequency may significantly underestimate contrast sensitivities of human vision for the dark light adaptation levels (low luminance values). Lower contrast sensitivities give rise to higher contrast thresholds, resulting in larger quantization step sizes in quantized luminance values.

[0062] Unlike the Digital Imaging and Communications in Medicine (DICOM) standard, a VDR curve under techniques as described herein does not fix the spatial frequency model parameter at a fixed value such as 4 cycles per degree. Rather, the VDR curve varies with the spatial frequency and accurately captures the peak contrast sensitivities of human vision at a plurality of light adaptation levels. The VDR curve properly takes into account the crispening effect due to human vision's adaptability to a wide range of light adaptation levels, and helps

generate a high-precision reference GSDF. Here, the term "high-precision" means that perceptual errors due to quantization of luminance values are removed or substantially reduced based on a reference GSDF that best and most efficiently captures human visual nonlinearity within the constraint of a fixed size code space (e.g., one of 10 bits, 12 bits, etc.).

[0063] A computation process may be used to calculate gray levels in the reference GSDF (e.g., TABLE 1). In an example embodiment, the computation process is iterative or recursive, repeatedly determines the contrast thresholds (or modulation threshold, for example, m_t in expression 4) from the VDR curve, and applies the contrast thresholds to obtain successive gray levels in the reference GSDF. This computation process may be implemented with the following expressions (7):

$$m_t = \frac{L_{\max} - L_{\min}}{L_{\max} + L_{\min}} \quad \text{so:} \quad L_{j+1} = L_j \frac{1+m_t}{1-m_t} \quad \text{and} \quad L_{j-1} = L_j \frac{1-m_t}{1+m_t} \quad \text{expressions (7)}$$

where $j-1$, j and $j+1$ represent indexes to three adjacent digital code values; L_{j-1} , L_j and L_{j+1} correspond to gray levels to which the digital code values $j-1$, j and $j+1$ are mapped, respectively. L_{\max} and L_{\min} respectfully represent maximum luminance value and minimum luminance value across a JND or a fraction of a JND. Using a JND or a fraction thereof maintains the high precision of the reference GSDF.

[0064] The contrast threshold m_t associated with the JND may be defined as a relative quantity, e.g., a difference between L_{\max} and L_{\min} , as divided by a particular luminance value of either L_{\max} or L_{\min} , or in between L_{\max} and L_{\min} (e.g., an average of L_{\max} and L_{\min}). In some embodiments, m_t may be alternatively defined as the difference between L_{\max} and L_{\min} , as divided by a multiplier (e.g., 2) of a particular luminance value of either L_{\max} or L_{\min} , or in between L_{\max} and L_{\min} . In quantizing luminance values in a GSDF to a plurality of gray levels, L_{\max} and L_{\min} may refer to adjacent gray levels in the plurality of gray levels. As a result, L_j may be related to L_{j-1} and L_{j+1} through m_t , respectively, as shown in expression (7).

[0065] In alternative embodiments, instead of using linear expressions as illustrated in expression (7), non-linear expression may be used to relate JNDs or contrast thresholds with gray levels. For example, an alternative expression based on the standard deviation divided by the mean may be used in place of a simple ratio for the contrast threshold as illustrated.

[0066] In some embodiments, a reference GSDF covers a range of 0 to 12,000 cd/m^2 with digital code values represented as 12-bit integer value. To further improve the precision of the reference GSDF, m_t may be multiplied with a fraction value f . Furthermore, a center digital value L_{2048} (note that the digital code values are at least limited to 0 and 4096 as in a 12-bit code space that is compatible with SDI) may be mapped to 100cd/m^2 . Expression (7) may yield the following expressions (8):

$$L_{2048} = 100\text{cd/m}^2 \quad L_{j-1} = L_j \frac{1+f*m_t}{1-f*m_t} \quad \text{and} \quad L_{j+1} = L_j \frac{1-f*m_t}{1+f*m_t} \quad \text{expression (8)}$$

wherein the fraction value f is set to 0.918177. In the example embodiment, the minimum

allowed value for the digital codes is set to code word (or integer value) 16 is set to 0 (cd/m²). The second lowest digital code value 17 ends up at 5.27×10^{-7} cd/m², while the digital code value 4076 ends up at 12,000 cd/m².

[0067] FIG. 3 illustrates an example GSDF that maps between a plurality of gray levels (in logarithmic luminance values) and a plurality of digital code values in a 12-bit code space, in accordance with an example embodiment of the present invention.

[0068] FIG. 4 illustrates a curve depicting Weber fractions (Delta L/L, or $\Delta L/L$) based on gray levels of the example GSDF of FIG. 3. Perceptual nonlinearity of human vision as illustrated by FIG. 4 is represented as a function of luminance values on a logarithmic luminance axis. Comparable visual differences (e.g., JNDs) of human vision correspond to larger Delta L/L values at lower luminance values. The curve of Weber fractions asymptotes to a constant value for high luminance values (e.g., a Weber fraction of 0.002 where Weber's law is met at higher luminance values).

7. FUNCTIONAL MODELS

[0069] One or more analytical functions may be used to obtain a mapping between digital code values and gray levels in a GSDF (reference GSDF or device-specific GSDF) as described herein. The one or more analytical functions may be proprietary, standard-based, or extensions from standard-based functions. In some embodiments, a GSDF generator (e.g., 504 of FIG. 5) may generate a GSDF in the form of one or more forward look-up tables (LUTs) and/or one or more inverse LUTs based on the one or more analytical functions (or formulas). At least some of these LUTs may be provided to a variety of image data codecs (e.g., 506 of FIG. 5) or a wide variety of display device to be used in converting between reference gray levels and reference digital code levels for the purpose of encoding reference image data. Additionally, optionally, or alternatively, at least some of the analytical functions (with their coefficients in integer or floating point representations) may be directly provided to image data codecs or a wide variety of display device to be used in obtaining mappings between digital code values and gray levels in a GSDF as described herein and/or converting between gray levels and digital code levels for the purpose of encoding image data.

[0070] In some embodiments, analytical functions as described herein comprise a forward function that may be used to predict a digital code value based on a corresponding gray level, as follows:

$$D = \left[\frac{c_1 + c_2 L^n}{1 + c_3 L^n} \right]^m \quad \text{expression (9)}$$

where D represents a (e.g., 12 bit) value of digital code, L represents a luminance value or gray level in nits, n may represent a slope in a middle section of a $\log D / \log L$ curve as given by expression (9), m may represent the sharpness of the knee of the $\log D / \log L$ curve, and c_1, c_2 and c_3 may define the end and middle points of the $\log D / \log L$ curve.

[0071] In some embodiments, the analytical functions comprise an inverse function that corresponds to the forward function in expression (9) and may be used to predict a luminance value based on a corresponding digital code value, as follows:

$$L = \left[\frac{D^{1/m} - c_1}{c_2 - c_3 D^{1/m}} \right]^{1/n} \quad \text{expression (10)}$$

[0072] Digital code values predicted based on a plurality of luminance values using expression (9) may be compared with observed digital code values. The observed digital code values may be, but are not limited only to any of, numeric calculation based on a CSF model as previously discussed. In an embodiment, a deviation between the predicted digital code values and the observed digital code values may be computed and minimized to derive optimal values of the parameters n , m , c_1 , c_2 , and c_3 in expression (9).

[0073] Likewise, luminance values predicted based on a plurality of digital code values using expression (10) may be compared with observed luminance values. The observed luminance values may, but are not limited to, be generated using numeric computations based on a CSF model as previously discussed, or using human visual experimentation data. In an embodiment, the deviation between the predicted luminance values and the observed luminance values may be derived as a function of the parameters n , m , c_1 , c_2 , and c_3 and minimized to derive optimal values of the parameters n , m , c_1 , c_2 , and c_3 in expression (10).

[0074] A set of optimal values of the parameters n , m , c_1 , c_2 , and c_3 as determined with expression (9) may or may not be the same as a set of optimal values of the parameters n , m , c_1 , c_2 , and c_3 as determined with expression (10). In case of differences between the two sets, one or both of the two sets may be used to generate a mapping between digital code values and luminance values. In some embodiments, the two sets of optimal values of the parameters n , m , c_1 , c_2 , and c_3 , if different, may be harmonized, for example, based on minimization of round trip errors, which are introduced by performing both forward and inverse coding operations with both expressions (9) and (10). In some embodiments, multiple round trips may be made to study resultant errors in digital code values and/or in luminance values or gray levels. In some embodiments, selection of the parameters in expressions (9) and (10) may be based at least in part on a criterion that no significant error occurs in one, two, or more round trips. Examples of no significant round trip errors may include, but are not limited only to any of, errors smaller than 0.0001%, 0.001%, 0.01%, 0.1%, 1%, 2%, or other configurable values.

[0075] Embodiments include using a code space of one of one or more different bit lengths to represent digital control values. Optimized values of the parameters in expressions (9) and (10) may be obtained for each of a plurality of code spaces each with a different one of one or more different bit lengths. Based on the optimized values of expressions (9) and (10), distributions of code errors (e.g., forward transformation errors, inverse transformation errors or round trip errors in digital code values based on expressions (9) and (10)) may be

determined. In some embodiments, a numeric difference of one (1) in two digital code values corresponds to a contrast threshold (or corresponds to a JND) at a light level between two luminance values represented by the two digital code values. FIG. 10A illustrates maximums for code errors in units of JNDs in a plurality of code spaces each with a different one of one or more different precisions (with different bit lengths), according to some example embodiments. For example, based on functional models as described herein, the maximum code error for a code space of infinite or unlimited bit length is 11.252. In comparison, based on a functional model as described herein, the maximum code error for a code space of a 12 bit length (or 4096) is 11.298. This indicates that a code space of a 12 bit length for digital code values is an excellent choice with a functional model as represented by expressions (9) and (10).

[0076] FIG. 10B illustrates a distribution of code errors for a code space of the 12 bit length (or 4096) with a forward transformation (from luminance values to digital code values) as specified by expression (9), according to an example embodiment. FIG. 10C illustrates a distribution of code errors for a code space of the 12 bit length (or 4096) with a backward transformation (from digital code values to luminance values) as specified by expression (10), according to an example embodiment. Both FIG. 10B and FIG. 10C indicate maximum code errors of less than 12.5.

[0077] FIG. 11 illustrates values of parameters that may be used in expressions (9) and (10), according to an example embodiment. In some embodiments, as illustrated, integer-based formulas may be used to represent/approximate these non-integer values in a specific implementation of a functional model as described herein. In some other embodiments, fixed point, floating point values with one of one or more precisions (e.g., 14-, 16-, or 32 bits) may be used to represent these non-integer values in a specific implementation of a functional model as described herein.

[0078] Embodiments include using a functional model with formulas other than those (which may be tone-mapping curves) given in expressions (9) and (10). For example, a cone model with a Naka-Rushton formula as follows may be used by a functional model as described herein:

$$L_d = \left[L_d^{\max} \left(\frac{L^n}{\sigma + L^n} \right) \right]^m \quad \text{expression (11)}$$

wherein L represent luminance values, n , m and σ represent model parameters in association with the cone model, and, L_d represents predicted values that may be encoded with digital code values. Similar methods of obtaining model parameters through minimizing deviations may be used to derive optimal values of the model parameters for expression (11). FIG. 10D illustrates a distribution of code errors for a code space of the 12 bit length (or 4096) with a forward transformation (from luminance values to digital code values) as specified by expression (11), according to an example embodiment. In an embodiment, the maximum code error as illustrated in FIG. 10D is 25 JNDs.

[0079] In another example, a functional model may be generated with a Raised mu formula as

follows:

$$y = (1 + \mu)^{x^{1.62}} \quad \text{expression (12)}$$

wherein x represents luminance values, and y represents predicted digital code values. An optimal value of the model parameter μ may be obtained through minimizing deviations. FIG. 10E illustrates a distribution of code errors for a code space of the 12 bit length (or 4096) with a forward transformation (from luminance values to digital code values) as specified by expression (12), according to an example embodiment. In an embodiment, the maximum code error as illustrated in FIG. 10E is 17 JNDs.

[0080] As illustrated herein, in some embodiments, a functional model may be used to predict code values from luminance values or predict luminance values from code values. Formulas used by the functional model may be invertible. Same or similar processing logic may be implemented to perform forward and inverse transformation between these values. In some embodiments, model parameters including but not limited only to any of exponents may be represented by fixed-point values or integer-based formulas. Thus, at least a part of the processing logic may be efficiently implemented in hardware only, software only, or a combination of hardware and software. Similarly, at least a part of LUTs generated with the functional model or model formulas (such as expressions (9) through (12)) may be efficiently implemented in hardware only, software only, or a combination of hardware and software (including ASIC or FPGA). In some embodiments, one, two, or more functional models may be implemented in a single computing device, a configuration of multiple computing devices, a server, etc. In some embodiments, errors in predicted code values may be within 14 code values of target or observed values over a full range of visible dynamic range of luminance values. In some embodiments, this holds true for both forward and inverse transformations. Same or different sets of model parameters may be used in forward and inverse transformations. Round-trip accuracy may be maximized with optimal values of the model parameters. Different code spaces may be used. In particular embodiment a code space of 12 bit length (4096) may be used to host digital code values with minimal code errors across the full range of visible dynamic range.

[0081] As used herein, a reference GSDF may refer to a GSDF comprising reference digital code values and reference gray levels as related under a functional model (the model parameters of which may be determined with target or observed values under a CSF model), as determined with numeric computations (e.g., without determining any functional representation of a mapping between digital code values and luminance values) based on a CSF model, or as determined with data from human visual studies. In some embodiments, a device GSDF may also comprise a mapping between digital code values and gray levels that may be analytically represented with a functional model as described herein.

8. EXCHANGE IMAGE DATA BASED ON REFERENCE GSDF

[0082] For the purpose of illustration, it has been described that digital code values reside in a

12 bit code space. The present invention, however, is not so limited. Digital code values with different code spaces (e.g., different bit depths other than 12 bits) may be used in a reference GSDF. For example, 10 bit integer values may be used to represent digital codes. Instead of mapping a digital code value 4076 to a luminance value 12000 cd/m² in a 12-bit representation of digital codes, a digital code value 1019 may be mapped to the luminance value 12000 cd/m² in a 10-bit representation of digital codes. Thus, these and other variations in code spaces (bit depths) may be used for digital code values in a reference GSDF.

[0083] The reference GSDF may be used to exchange image data across different GSDFs which may be individually designed for each type of image acquisition device or image rendering device. For example, a GSDF implemented with a specific type of image acquisition device or image rendering device may implicitly or explicitly depend on model parameters that do not match model parameters of a standard GSDF or a device-specific GSDF with another type of image acquisition device or image rendering device.

[0084] A reference GSDF may correspond to curve shapes as depicted in FIG. 3 and FIG. 4. Generally speaking, the shapes of GSDFs depend on parameters used to derive or design the GSDFs. Hence, a reference GSDF depends on a reference CSF model and reference model parameters used to generate the reference GSDF from the reference CSF model. The curve shape of a device-specific GSDF depends on the specific device, including display parameters and viewing conditions if the specific device is a display.

[0085] In an example, a display whose supported range of luminance values is limited to less than 500 cd/m² may not experience the increase in slope at a high luminance value region (which occurs when the human vision shifts to a logarithmic behavior for all frequencies) as shown in FIG. 3. Driving the display with a curve shape of FIG. 3 may lead to nonoptimal (e.g., suboptimal) allocation of gray levels, with too many gray levels allocated in the bright regions, and not enough allocated in the dark regions.

[0086] In another example, a low contrast display is designed to be used outdoors in various daylight conditions. The display's luminance range may occur largely or almost entirely in the log behavior region of FIG. 3. Driving this low contrast display with a curve shape of FIG. 3 may also lead to nonoptimal (suboptimal) allocation of gray levels, with too many gray levels allocated in the dark regions, and not enough allocated in the bright regions.

[0087] Under techniques as described herein, each display may use its specific GSDF (dependent on not only the display parameters, but also on the viewing conditions which, for example, affect the actual black level) to optimally support perceptual information in image data encoded with a reference GSDF. The reference GSDF is used by one or more upstream (e.g., encoding) devices for the overall encoding of image data to preserve perceptual details as much as possible. The image data encoded in the reference GSDF is then delivered to one or more downstream (e.g., decoding) devices. In an example embodiment, encoding of image data based on the reference GSDF is independent of specific devices that are to subsequently

decode and/or render the image data.

[0088] Each device (e.g., display) has its specific GSDF where device-specific gray levels are supported/optimized. The specific gray levels may be known to the maker of the display, or may have been specifically designed by the maker to support the device-specific GSDF (which may or may not be standard based). The line driver of the device may be implemented with quantized luminance values specific to the device. Optimization may be best done for the device based on the quantized luminance values specific to the device. Additionally, the dark black level (e.g., the lowest device-specific gray level), which may be used as the lower bound to the range of device-specific gray levels, may be set based in part on the present ambient light level and/or the device's optical reflectivity (which may be known to the maker). Once the dark black level is so set, device-specific gray levels may be obtained or set by implicitly or explicitly accumulating (e.g., stacking/integrating) quantization steps in the line driver of the device. The derivation and/or adjustment of gray levels may or may not be done at runtime when the device is concurrently rendering images.

[0089] Thus, under techniques as described herein, embodiments of the present invention may include, but are not limited only to, encoding image data with a reference GSDF and decoding and rendering the image data with a display-specific GSDF.

[0090] Techniques as described herein may be used to exchange image data across a variety of devices with different GSDFs. FIG. 5 illustrates an example framework (500) of exchange image data with devices of different GSDFs, in accordance with an example embodiment of the present invention. As illustrated in FIG. 5, an adaptive CSF model (502) may be used to generate a reference GSDF (504). The term "adaptive" may refer to the adaptability of a CSF model to human visual nonlinearity and behaviors. The adaptive CSF model may be built based at least in part on a plurality of CSF parameters (or model parameters). The plurality of model parameters include, for example, light adaptation level, display area in degree width, noise level, accommodation (physical viewing distance), luminance or color modulation vector (which may be, for example, related to test images or image patterns used in the adaptive CSF model (502)).

[0091] An upstream (e.g., encoding) device may receive image data to be encoded with the reference GSDF (504) before the image data or its derivative is transmitted or distributed to downstream (e.g., decoding) devices. The image data to be encoded may initially be in any of a plurality of formats (standard based, proprietary, extension thereof, etc.) and/or may be derived from any of a plurality of image sources (camera, image server, tangible media, etc.). Examples of image data to be encoded include, but are not limited only to, raw or other high bit-depth image(s) 530. The raw or other high bit-depth image(s) may come from a camera, a studio system, an art director system, another upstream image processing system, an image server, a content database, etc. The image data may include, but is not limited only to, that of digital photos, video image frames, 3D images, non-3D images, computer-generated graphics, etc. The image data may comprise scene-referred images, device-referred images, or images with various dynamic ranges. Examples of image data to be encoded may include a high-

quality version of original images that are to be edited, down-sampled, and/or compressed, along with metadata, into a coded bitstream for distribution to image receiving systems (downstream image processing system such as displays of various makers). The raw or other high bit-depth image(s) may be of a high sampling rate used by a professional, an art studio, a broadcast company, a high-end media production entity, etc. Image data to be encoded may also be in whole or in part computer generated, or may even be obtained based in whole or in part from existing image sources such as old movies and documentaries.

[0092] As used herein, the phrase "image data to be encoded" may refer to image data of one or more images; the image data to be encoded may comprise floating-point or fixed-point image data, and may be in any color space. In an example embodiment, the one or more images may be in an RGB color space. In another example embodiment, the one or more images may be in a YUV color space. In an example, each pixel in an image as described herein comprises floating-point pixel values for all channels (e.g., red, green, and blue color channels in the RGB color space) defined in the color space. In another example, each pixel in an image as described herein comprises fixed-point pixel values for all channels (e.g., 16 bits or higher/lower numbers of bits fixed-point pixel values for red, green, and blue color channels in the RGB color space) defined in the color space. Each pixel may optionally and/or alternatively comprise downsampled pixel values for one or more of the channels in the color space.

[0093] In some embodiments, in response to receiving the image data to be encoded, an upstream device in the framework (500) maps luminance values as specified by or determined from the image data to reference digital code values in the reference GSDF, and generates, based on the image data to be encoded, reference encoded image data encoded with the reference digital code values. The mapping operation, from the luminance values based on the image data to be encoded to the reference digital code values, may include selecting reference digital code values whose corresponding reference gray levels (e.g., as shown in TABLE 1) match, or approximate as closely as any other reference luminance values in the reference GSDF, the luminance values as specified by or determined from the image data to be encoded and replacing the luminance values with the reference digital code values in the reference encoded image data.

[0094] Additionally, optionally or alternatively, preprocessing and post processing steps (which may include, but are not limited only to, color space conversion, down sampling, upsampling, tone mapping, color grading, decompression, compression, etc.) may be performed as a part of generating the reference encoded image data.

[0095] In an example embodiment, the framework (500) may comprise software and/or hardware components (e.g., an encode or format unit (506)) configured to encode and/or format the reference encoded image data into one or more coded bitstreams or image files. The coded bitstreams or image files may be in a standard-based format, a proprietary format, or an extension format based at least in part on a standard-based format. Additionally and/or optionally, the coded bitstreams or image files may comprise metadata containing one or more of related parameters (e.g., model parameters; minimum luminance value, maximum

luminance value, minimum digital code value, maximum digital code value, etc., as illustrated in TABLE 1, FIG. 3 and FIG. 4; an identifying field that identifies a CSF among a plurality of CSFs; reference viewing distance) related to the reference GSDF, pre-processing or post processing used to generate the reference encoded image data.

[0096] In some embodiments, the framework (500) may comprise one or more discrete upstream devices. For example, at least one of the one or more upstream devices in the framework (500) may be configured to encode image data based on the reference GSDF. The upstream devices may comprise software and/or hardware components configured to perform the functionality related to 502, 504, and 506, of FIG. 5. The coded bitstreams or image files may be outputted by the upstream devices (502, 504, and 506, of FIG. 5) through network connections, digital interfaces, tangible storage media, etc., and delivered in an image data flow (508) to other image processing devices for processing or rendering.

[0097] In some example embodiments, the framework (500) further comprises one or more downstream devices as one or more discrete devices. The downstream devices may be configured to receive/access, from the image data flow (508), the coded bitstreams or image files outputted by the one or more upstream devices. For example, the downstream devices may comprise software and/or hardware components (e.g., a decode or reformat unit (510)) configured to decode and/or reformat the coded bitstreams and image files, and recover/retrieve the reference encoded image data therein. As illustrated in FIG. 5, the downstream devices may comprise a diverse set of display devices.

[0098] In some embodiments, a display device (not shown) may be designed and/or implemented to support the reference GSDF. High-precision HDR image rendering may be provided if the display device supports each and every gray level in the reference GSDF. The display device may render images at details at a finer level than, or at the same level as, what human vision may possibly detect.

[0099] In some embodiments, a display device's native digital code values (which may be implemented as digitized voltage values, e.g., digital drive levels or DDLs, in the display system) in a device-specific GSDF may correspond to device-specific gray levels (or luminance values) different from those in the reference GSDF. The device-specific gray levels may be designed to support sRGB, Rec. 709, or other specifications including those using representations related to complementary densities. Additionally, optionally, or alternatively, the device-specific gray levels may be based on the essential DAC characteristics of display driving.

[0100] In some embodiments, a display device A (512-A) may be designed and/or implemented to support a device-specific GSDF A (514-A) of a visible dynamic range (VDR) display. GSDF A (514-A) may be based on a bit depth of 12 bits (a 12 bit code space) for device-specific digital code values, a 10,000: 1 contrast ratio (CR), and a >P3 gamut. GSDF A (514-A) may support gray levels within a first sub-range (e.g., 0 to 5,000 cd/m²) in the entire range of the reference GSDF (504). Alternatively and/or optionally, GSDF A (514-A) may

support the entire range (0 to 12,000 cd/m², for example) in the reference GSDF (504) but may comprise fewer than all the reference gray levels in the reference GSDF (504).

[0101] In some embodiments, a display device B (512-B) may be designed and/or implemented to support a device-specific GSDF B (514-B) for a dynamic range narrower than the VDR. For example, display device B (512-B) may be a standard dynamic range (SDR) display. As used herein, the terms "standard dynamic range" and "low dynamic range," and/or their corresponding abbreviations "SDR" and "LDR" may be used synonymously and/or interchangeably. In some embodiments, GSDF B (514-B) may support a bit depth of 8 bits for device-specific digital code values, a 500-5,000:1 contrast ratio (CR), and a color gamut as defined in Rec. 709. In some embodiments, GSDF B (514-B) may provide gray levels within a second sub-range (e.g., 0 to 2000 cd/m²) of the reference GSDF (504).

[0102] In some embodiments, a display device C (512-C) may be designed and/or implemented to support a device-specific GSDF C (514-C) for a dynamic range even narrower than the SDR. For example, display device C (512-C) may be a tablet display. In some embodiments, GSDF C (514-C) may support a bit depth of 8 bits for device-specific digital code values, a 100-800:1 contrast ratio (CR), and a color gamut smaller than that defined in Rec. 709. In some embodiments, GSDF C (514-C) may support gray levels within a third sub-range (e.g., 0 to 1,200 cd/m²) of the reference GSDF (504).

[0103] In some embodiments, a display device (e.g., display device D (512-D)) may be designed and/or implemented to support a device-specific GSDF (e.g., GSDF D (514-D)) for a very limited dynamic range much narrower than the SDR. For example, display device D (512-D) may comprise an e-paper display. In some embodiments, GSDF D (514-D), may support a bit depth of 6 bits or less for device-specific digital code values; a contrast ratio (CR) of 10: 1 or less, and a color gamut much smaller than that defined in Rec. 709. In some embodiments, GSDF D (514-D) may support gray levels within a fourth sub-range (e.g., 0 to 100 cd/m²) of the reference GSDF (504).

[0104] Precision in image rendering may be gracefully scaled down with each of display devices A through D (512-A through -D). In some embodiments, the subset of gray levels in each of device specific GSDF A through D (514-A through -D) may be correlated with, or mapped to, supported reference gray levels in the reference GSDF (504) in such a way as to evenly distribute perceptually noticeable errors in the range of gray levels supported by that display device.

[0105] In some embodiments, a display device (e.g., one of 512-A through -D) with a device-specific GSDF (e.g., one of 514-A through -D) receives/extracts reference encoded image data encoded based on a reference GSDF. In response, the display device, or a conversion unit (one of 516-A through -D) therein, maps reference digital code values as specified in the reference encoded image data, to device-specific digital code values that are native to the display device. This may be performed in one of several ways. In an example, mapping from

the reference digital code values to the device-specific digital code values includes selecting device-specific gray levels (corresponding to the device-specific digital code values) that match, or approximate as closely as any other device-specific gray levels, the reference gray levels (corresponding to the reference digital code values). In another example, mapping from the reference digital code values to the device-specific digital code values includes (1) determining tone-mapped luminance values based on the reference gray levels (corresponding to the reference digital code values) associated with the reference GSDF, and (2) selecting device-specific gray levels (corresponding to the device-specific digital code values) that match, or approximate as closely as any other device-specific gray levels, the tone-mapped luminance values.

[0106] Subsequently, the display device, or a driver chip (one of 518-A through -D) therein, may use the display-specific digital code values to render images with device-specific gray levels that correspond to the display-specific code values.

[0107] Generally speaking, a reference GSDF may be based on a different CSF model than that on which a display-specific GSDF is based. Conversion/mapping between the reference GSDF and the device-specific GSDF is necessary. Even if the same CSF model is used to generate both the reference GSDF and a device-specific GSDF, different values of model parameters may be used in deriving the GSDFs. For the reference GSDF, model parameter values may be conservatively set to preserve details for a wide variety of downstream devices, while for the device-specific GSDF, model parameter values may reflect specific design/implementation and viewing conditions under which the display device is to render images. Conversion/mapping between the reference GSDF and the device-specific GSDF is still necessary, as the specific display device's viewing condition parameters (e.g., the ambient light level, the display device's optical reflectivity, etc.) are different from the model parameter values used to derive the reference GSDF. Here, the viewing condition parameters may include those that impinge display quality (e.g., contrast ratio, etc.) and elevate the black level (e.g., the lowest gray level, etc.). Conversion/mapping between the reference GSDF and the device-specific GSDF under techniques as described herein improves quality in image rendering (e.g., improve the contrast ratio by increasing luminance values at high value regions, etc.).

9. CONVERTING REFERENCE ENCODED DATA

[0108] FIG. 6 illustrates an example conversion unit (e.g., 516), in accordance with some embodiments of the present invention. The conversion unit (516) may, but is not limited only to, be one (e.g., 516-A) of a plurality of conversion units (e.g., 516-A through -D) as illustrated in FIG. 5. In some embodiments, the conversion unit (516) may receive first definition data for a reference GSDF (REF GSDF) and second definition data for a device-specific GSDF (e.g., GSDF-A (514-A of FIG. 5)). As used herein, the terms "device-specific" and "display-specific" may be used interchangeably, if the device is a display.

[0109] Based on the definition data received, the conversion unit (516) cascades the reference GSDF with display-specific GSDF to form a conversion lookup table (Conversion LUT). Cascading between the two GSDFs may include comparing gray levels in the two GSDFs, and based on the results of comparing gray levels, establishing a mapping between reference digital code values in the reference GSDF and display-specific digital code values in the display-specific GSDF.

[0110] More specifically, given a reference digital code value in the reference GSDF, its corresponding reference gray level may be determined based on the reference GSDF. The reference gray level so determined may be used to locate a device-specific gray level in the display-specific GSDF. In an example embodiment, the device-specific gray level located may match, or approximate as closely as any other display-specific gray levels in the display-specific GSDF, the reference gray level. In another example embodiment, a tone-mapped luminance value may be obtained by a global or local tone-mapping operator acting on the reference gray level; the device-specific gray level located may match, or approximate as closely as any other display-specific gray levels in the display-specific GSDF, the tone-mapped luminance value.

[0111] With the device-specific gray level, a corresponding display-specific digital code value may be identified from the display-specific GSDF. An entry may be added or defined in the conversion LUT, consisting of the reference digital code value and the display-specific code value.

[0112] The steps as described above may be repeated for other reference digital code values in the reference GSDF.

[0113] In some embodiments, a conversion LUT may be pre-built and stored before image data whose processing is to be done based in part on the conversion LUT is received and processed. In alternative embodiments, image data that is to be processed with a conversion LUT is analyzed. The results of the analysis may be used to set up or at least adjust correspondence relationships between the reference digital code values and the device-specific digital code values. For example, if the image data indicates a particular concentration or distribution of luminance values, the conversion LUT may be set up in a way to preserve a large amount of details in the concentrated region of luminance values.

[0114] In some embodiments, the conversion unit (516) comprises one or more software and/or hardware components (a comparison sub-unit (602)) configured to compare quantization steps (e.g., luminance value differences, or Δ Ls, between adjacent digital code values) in both the reference GSDF and display-specific GSDF (514-A). For example, the quantization step at a reference digital code value in the reference GSDF may be a reference luminance value difference (reference GSDF Δ L), while the quantization step at a display-specific digital code value in the display-specific GSDF may be a display-specific luminance value difference (display-specific GSDF Δ L). Here, the display-specific digital code value corresponds to (or forms a pair in the conversion LUT with) the reference digital code value. In

some embodiments, the comparison sub-unit (602) compares these two luminance value differences. This operation is essentially a test which may be performed either based on ΔL values, or optionally and/or alternatively, based on the relative slopes of the two GSDF curves.

[0115] Quantization steps for luminance values in the display-specific GSDF may typically exceed those of the reference GSDF, as one or more reference gray levels from the reference GSDF (e.g., corresponding to a high bit-depth domain, etc.) are merged into display-specific gray levels from the display-specific GSDF (e.g., corresponding to a low bit-depth domain, etc.). In these cases, dithering is used to remove banding artifacts. As part of overall dithering, dithering is also performed on local surrounding output pixels (in space and/or in time). In a sense, the human eye may be represented as a low-pass filter. At least in this sense, averaging local surrounding pixels as described herein thus creates desired output gray levels that reduce and/or remove banding visual artifacts, which otherwise could be present due to large quantization steps in the display-specific GSDF.

[0116] In less common cases, quantization steps for luminance values for the reference GSDF may occasionally exceed those of the display-specific GSDF. A decontouring algorithm-based process is used, synthesizing an output gray level based on an input gray level, for example, by averaging neighboring input pixels.

[0117] Correspondingly, if the reference GSDF ΔL is greater than the display-specific GSDF ΔL , which is the "Y" path in FIG. 6, then a decontour algorithm flag is set for an entry, in the conversion LUT, that comprises the reference digital code value and the display-specific digital code value.

[0118] If the reference GSDF ΔL is less than the display-specific GSDF ΔL , which is the "N" path in FIG. 6, then a dither algorithm flag is set for an entry, in the conversion LUT, that comprises the reference digital code value and the display-specific digital code value.

[0119] If the reference GSDF ΔL is equal to the display-specific GSDF ΔL , then neither a decontour algorithm flag nor a dither algorithm flag is set for an entry, in the conversion LUT, that comprises the reference digital code value and the display-specific digital code value.

[0120] Decontour and dither algorithm flags may be stored with entries in the conversion LUT, or may be stored in a related data structure outside, but operatively linked with, the conversion LUT.

[0121] In some embodiments, the conversion unit (516) is configured to receive reference encoded image data, which may be in the form of high bit-depth or floating point input image, and to map reference digital code values specified in the reference GSDF to display-specific digital code values specified in the display-specific GSDF. In addition to mapping digital code values between the GSDFs, the conversion unit (516) may be configured to perform decontouring or dithering based on the settings of algorithm flags (decontour algorithm flags or dithering algorithm flags) previously discussed.

[0122] As noted, the reference GSDF likely contains a greater amount of details than a display-specific GSDF; thus, the "Y" path of FIG. 6 may not occur, or may occur less often. In some embodiments, the "Y" path and related processing may be omitted to simplify the implementation of a conversion unit.

[0123] In some embodiments, given a reference digital code value as determined for a pixel in the reference encoded image data, the conversion unit (516) looks up in the conversion LUT for a corresponding display-specific digital code value, and replaces the reference digital code value with the corresponding display-specific digital code value. Additionally and/or optionally, the conversion unit (516) determines whether a decontour or dithering algorithm should be performed for the pixel, based on the existence/setting of an algorithm flag for an entry, in the conversion LUT, that comprises the reference digital code value and the display-specific digital code value.

[0124] If it is determined that neither a decontour algorithm nor a dithering algorithm should be performed (e.g., no indication or flag for performing either algorithm), then no decontour or dithering is performed for the pixel for the time being.

[0125] If it is determined that a decontour algorithm should be performed, then the conversion unit (516) may perform one or more decontour algorithms (Decontour Algo). Performing the one or more decontour algorithms may include receiving image data of input local neighborhood pixels and inputting the image data of the local neighborhood pixels to the decontour algorithms.

[0126] If it is determined that a dithering algorithm should be performed, then the conversion unit (516) may perform one or more dithering algorithms (Dithering Algo).

[0127] The pixel may still be involved in decontour or dithering if the conversion unit (516) determines that decontour or dithering needs to be performed with respect to neighborhood pixels. In an example, the device-specific (output) gray level of the pixel may be used for dithering local neighborhood pixels. In another example, the reference (input) gray level of the pixel may be used for decontouring local neighborhood pixels.

[0128] In some embodiments, the conversion unit (516) outputs the processing results of the foregoing steps to downstream processing units or sub-units. The processing results comprise display-specific encoded image data in the format of display-specific bit-depth output image encoded with digital code values in the display-specific GSDF (e.g., GSDF-A).

[0129] FIG. 7 illustrates an example SDR display (700) which implements 8 bit image processing. The SDR display (700), or a VDR decode unit (702) therein, receives an encoded input. The encoded input comprises reference coded image data in an image data container which may be in one of a plurality of image data container formats. The VDR decode unit (702) decodes the encoded input and determines/retrieves the reference encoded image data from

therein. The reference encoded image data may comprise image data for individual pixels in a color space (e.g., a RGB color space, a YCbCr color space, etc.). The image data for individual pixels may be encoded with reference digital code values in a reference GSDF.

[0130] Additionally and/or optionally, the SDR display (700) comprises a display management unit (704) that maintains display parameters for the SDR display (700). The display parameters may at least in part define a display-specific GSDF (e.g., GSDF-B of FIG. 5) associated with the SDR display (700). The display parameters defining the display-specific GSDF may include maximum (max) and minimum (min) gray levels supported by the SDR display (700). The display parameters may also include color primaries (primaries) supported by the SDR display, display size (size), optical reflectivity of the SDR display's image rendering surface, ambient light level. Some of the display parameters may be preconfigured with fixed values. Some of the display parameters may be measured in real-time or near real-time by the SDR display (700). Some of the display parameters may be configurable by a user of the SDR display (700). Some of the display parameters may be preconfigured with default values and may be overridden by measurement or by a user. The display management unit (704) establishes/shapes perceptual nonlinearity of the display-specific gray levels based on the reference GSDF, and may additionally and/or optionally perform tone mapping as a part of establishing/shaping the display-specific gray levels. For example, a conversion LUT as illustrated in FIG. 5 and/or other related meta data (e.g., dithering and decontour processing flags, etc.) may be established by the display management unit (704) for the purpose of establishing/shaping perceptual nonlinearity of the display-specific gray levels in accordance with the reference GSDF. Cascading operations as previously discussed may be implemented with the display management unit (704) to create the conversion LUT and/or other related metadata (712) relating to one or both of the reference GSDF and display-specific GSDF. The conversion LUT and/or other related metadata (712) may be accessed and used by other units or sub-units in the SDR display (700). Further, the conversion LUT and/or other related metadata may be used as, or to derive, metadata (714) for inverting perceptual nonlinearity. As used herein, inverting perceptual nonlinearity may include converting display-specific digital code values to display-specific digital driving levels (e.g., digitized voltage levels in the display device).

[0131] Additionally and/or optionally, the SDR display (700) includes a conversion unit (516) as illustrated in FIG. 5 and FIG. 6, and an 8 bit perceptual quantizer (706). In some embodiments, the SDR display (700), or the conversion unit (516) and the 8 bit perceptual quantizer (706) therein, converts the reference encoded image data into a display-specific bit-depth output image encoded with display-specific digital code values associated with the display-specific GSDF (e.g., GSDF-A or GSDF-B of FIG. 5), and quantizes the display-specific bit-depth output image into perceptually encoded image data in a 8 bit code space. As used herein, the term "perceptually encoded" may refer to a type of encoding that is based on a human visual perceptual model, such as a CSF that gives rise to the reference GSDF.

[0132] Additionally and/or optionally, the SDR display (700) comprises a video post-processing unit (708) that may, but is not limited only to, perform zero, one, or more of image processing

operations on the perceptually encoded image data in an 8 bit luminance representation. These image processing operations may include, but are not limited only to, compression, decompression, color space conversion, downsampling, upsampling, or color grading. The results of these operations may be outputted to other parts of the SDR display (700).

[0133] In an example embodiment, the SDR display (700) comprises an 8 bit inverse perceptual quantizer (710) configured to convert display-specific digital code values in the results of image processing operations to display-specific digital driving levels (e.g., digitized voltage levels). The display-specific digital driving levels generated (or converted back from digital code values) by the inverse perceptual quantizer (710) may specifically support one of several types of luminance nonlinearities supportable in the SDR display (700). In an example, the inverse perceptual quantizer (710) converts display-specific digital code values to display-specific digital driving levels to support luminance nonlinearities associated with Rec. 709. In another example, the inverse perceptual quantizer (710) converts display-specific digital code values to display-specific digital driving levels to support luminance nonlinearities associated with a linear luminance domain or a log luminance domain (which may be relatively easy to be integrated with local dimming operations). In another example, the inverse perceptual quantizer (710) converts display-specific digital code values to display-specific digital driving levels to support a display-specific CSF (or its associated GSDF), with optimal placement of display-specific gray levels for the specific display (700), and possibly adjusted for the viewing conditions specific to the display (700).

10. EXAMPLE PROCESS FLOWS

[0134] FIG. 8A illustrates an example process flow according to an embodiment of the present invention. In some embodiments, one or more computing devices or components such as one or more computing devices in framework (500) may perform this process flow. In block 802, a computing device receives image data to be encoded.

[0135] In block 804, the computing device encodes, based on a reference mapping between a set of reference digital code values and a set of reference gray levels, the image data to be encoded into reference encoded image data. Here, luminance values in the image data to be encoded are represented by the set of reference digital code values. A luminance difference between two reference gray levels represented by two adjacent reference digital code values in the set of reference digital code values may be inversely proportional to a peak contrast sensitivity of human vision adapted at a particular light level.

[0136] In block 806, the computing device outputs the reference encoded image data.

[0137] In an embodiment, the computing device determines a reference gray scale display function (GSDF) based on a contrast sensitivity function (CSF) model; the reference GSDF specifies the reference mapping between the set of reference digital code values and the set of reference gray levels. The CSF model comprises one or more model parameters, which may

have an angular size that falls in a range comprising one or more of: between 25 degrees × 25 degrees and 30 degrees × 30 degrees, between 30 degrees × 30 degrees and 35 degrees × 35 degrees, between 35 degrees × 35 degrees and 40 degrees × 40 degrees, between 40 degrees × 40 degrees and 45 degrees × 45 degrees, or greater than 45 degrees × 45 degrees.

[0138] In an embodiment, the computing device assigns an intermediate luminance value, within a range of luminance values supported by the set of reference gray levels, to an intermediate digital code value in a code space that hosts the set of reference digital code values, and derives, by performing one or more of stacking or integration computations, a plurality of sub-mappings, each sub-mapping maps a reference digital code value in the set of reference digital code values to a reference gray level in the set of reference gray levels. The intermediate luminance value may be selected within a range comprising one or more of: less than 50 nits, between 50 nits and 100 nits inclusive, between 100 and 500 nits inclusive, or no less than 500 nits.

[0139] In an example embodiment, the set of reference gray levels covers a dynamic range with an upper limit having a value of: less than 500 nits, between 500 nits and 1000 nits inclusive, between 1000 and 5000 nits inclusive, between 5000 nits and 10000 nits inclusive, between 10000 nits and 15000 nits inclusive, or greater than 15000 nits.

[0140] In an embodiment, the peak contrast sensitivity is determined from a contrast sensitivity curve among a plurality of contrast sensitivity curves determined based on a contrast sensitivity function (CSF) model having model parameters comprising one or more of a luminance value variable, a spatial frequency variable, or one or more other variables.

[0141] In an embodiment, at least two peak contrast sensitivities determined based on at least two contrast sensitivity curves in the plurality of contrast sensitivity curves occur at two different spatial frequency values.

[0142] In an embodiment, the computing device converts one or more input images represented, received, transmitted, or stored with the image data to be encoded from an input video signal into one or more output images represented, received, transmitted, or stored with the reference encoded image data contained in an output video signal.

[0143] In an embodiment, the image data to be encoded comprises image data encoded in one of a high-resolution high dynamic range (HDR) image format, a RGB color spaces associated with the Academy Color Encoding Specification (ACES) standard of the Academy of Motion Picture Arts and Sciences (AMPAS), a P3 color space standard of the Digital Cinema Initiative, a Reference Input Medium Metric/Reference Output Medium Metric (RIMM/ROMM) standard, an sRGB color space, a RGB color space associated with the BT.709 Recommendation standard of the International Telecommunications Union (ITU), etc.

[0144] In an embodiment, the luminance difference between the two reference gray levels

represented by the two adjacent reference digital code values is less than a just noticeable difference threshold at the particular light level.

[0145] In an embodiment, the particular light level is a luminance value between the two luminance values, inclusive.

[0146] In an embodiment, the set of reference digital code values comprises integer values in a code space with a bit depth of: less than 12 bits; between 12 bits and 14 bits, inclusive; at least 14 bits; 14 bits or more.

[0147] In an embodiment, the set of reference gray levels may comprise a set of quantized luminance values.

[0148] FIG. 8B illustrates another example process flow according to an embodiment of the present invention. In some embodiments, one or more computing devices or components such as one or more computing devices in framework (500) may perform this process flow. In block 852, a computing device determines a digital code mapping between a set of reference digital code values and a set of device-specific digital code values. Here, the set of reference digital code values is mapped in a reference mapping to a set of reference gray levels, while the set of device-specific digital code values is mapped in a device-specific mapping to a set of device-specific gray levels.

[0149] In block 854, the computing device receives reference encoded image data encoded with the set of reference digital code values. Luminance values in the reference encoded image data are based on the set of reference digital code values. A luminance difference between two reference gray levels represented by two adjacent reference digital code values in the set of reference digital code values may be inversely proportional to a peak contrast sensitivity of human vision adapted at a particular light level.

[0150] In block 856, the computing device transcodes, based on the digital code mapping, the reference encoded image data encoded with the set of reference digital code values into device-specific image data encoded with the set of device-specific digital control codes. Luminance values in the device-specific image data are based on the set of device-specific digital code values.

[0151] In an embodiment, the computing device determines a set of correspondence relationships between the set of reference digital code values and the set of device-specific digital code values. Here, a correspondence relationship in the set of correspondence relationship relates a reference digital code value in the set of reference digital code values to a device-specific digital code value. The computing device further compares a first luminance difference at the reference digital code value and a second luminance difference at the device-specific digital code value, and stores, based on comparing the first luminance difference and the second luminance difference, an algorithm flag as to whether dithering, decontouring, or no operation should be performed for the reference digital code value.

[0152] In an embodiment, the computing device determines a reference digital code value from the reference encoded image data for a pixel, and further determines whether an algorithm flag is set for the reference digital code value. In response to determining that an algorithm flag is set for decontour, the computing device performs a decontour algorithm on the pixel. Alternatively, in response to determining that an algorithm flag is set for dithering, the computing device performs a dithering algorithm on the pixel.

[0153] In an embodiment, the computing device renders one or more images on a display based on the device-specific image data encoded with the set of device-specific digital control codes. Here, the display may be, but is not limited only to, one of a visible dynamic range (VDR) display, a standard dynamic range (SDR) display, a tablet computer display, or a handheld device display.

[0154] In an embodiment, a device-specific gray scale display function (GSDF) specifies the device-specific mapping between the set of device-specific digital code values and the set of device-specific gray levels.

[0155] In an embodiment, the device-specific mapping is derived based on one or more display parameters and zero or more viewing condition parameters.

[0156] In an embodiment, the set of device-specific gray levels covers a dynamic range with an upper limit having a value of: less than 100 nits, no less than 100 nits but less than 500 nits, between 500 nits and 1000 nits inclusive, between 1000 and 5000 nits inclusive, between 5000 nits and 10000 nits inclusive, or greater than 10000 nits.

[0157] In an embodiment, the computing device converts one or more input images represented, received, transmitted, or stored with the reference encoded image data from an input video signal into one or more output images represented, received, transmitted, or stored with the device-specific image data contained in an output video signal.

[0158] In an embodiment, the device-specific image data supports image rendering in one of a high-resolution high dynamic range (HDR) image format, a RGB color spaces associated with the Academy Color Encoding Specification (ACES) standard of the Academy of Motion Picture Arts and Sciences (AMPAS), a P3 color space standard of the Digital Cinema Initiative, a Reference Input Medium Metric/Reference Output Medium Metric (RIMM/ROMM) standard, an sRGB color space, or a RGB color space associated with the BT.709 Recommendation standard of the International Telecommunications Union (ITU).

[0159] In an embodiment, the set of device-specific digital code values comprises integer values in a code space with a bit depth of: 8 bits; greater than 8 but less than 12 bits; 12 bits or more.

[0160] In an embodiment, the set of device-specific gray levels may comprise a set of

quantized luminance values.

[0161] In various embodiments, an encoder, a decoder, a system, etc., performs any or a part of the foregoing methods as described.

11. IMPLEMENTATION MECHANISMS - HARDWARE OVERVIEW

[0162] According to one embodiment, the techniques described herein are implemented by one or more special-purpose computing devices. The special-purpose computing devices may be hard-wired to perform the techniques, or may include digital electronic devices such as one or more application-specific integrated circuits (ASICs) or field programmable gate arrays (FPGAs) that are persistently programmed to perform the techniques, or may include one or more general purpose hardware processors programmed to perform the techniques pursuant to program instructions in firmware, memory, other storage, or a combination. Such special-purpose computing devices may also combine custom hard-wired logic, ASICs, or FPGAs with custom programming to accomplish the techniques. The special-purpose computing devices may be desktop computer systems, portable computer systems, handheld devices, networking devices or any other device that incorporates hard-wired and/or program logic to implement the techniques.

[0163] For example, FIG. 9 is a block diagram that illustrates a computer system 900 upon which an example embodiment of the invention may be implemented. Computer system 900 includes a bus 902 or other communication mechanism for communicating information, and a hardware processor 904 coupled with bus 902 for processing information. Hardware processor 904 may be, for example, a general purpose microprocessor.

[0164] Computer system 900 also includes a main memory 906, such as a random access memory (RAM) or other dynamic storage device, coupled to bus 902 for storing information and instructions to be executed by processor 904. Main memory 906 also may be used for storing temporary variables or other intermediate information during execution of instructions to be executed by processor 904. Such instructions, when stored in non-transitory storage media accessible to processor 904, render computer system 900 into a special-purpose machine that is customized to perform the operations specified in the instructions.

[0165] Computer system 900 further includes a read only memory (ROM) 908 or other static storage device coupled to bus 902 for storing static information and instructions for processor 904. A storage device 910, such as a magnetic disk or optical disk, is provided and coupled to bus 902 for storing information and instructions.

[0166] Computer system 900 may be coupled via bus 902 to a display 912, such as a liquid crystal display, for displaying information to a computer user. An input device 914, including alphanumeric and other keys, is coupled to bus 902 for communicating information and command selections to processor 904. Another type of user input device is cursor control 916,

such as a mouse, a trackball, or cursor direction keys for communicating direction information and command selections to processor 904 and for controlling cursor movement on display 912. This input device typically has two degrees of freedom in two axes, a first axis (e.g., x) and a second axis (e.g., y), that allows the device to specify positions in a plane.

[0167] Computer system 900 may implement the techniques described herein using customized hard-wired logic, one or more ASICs or FPGAs, firmware and/or program logic which in combination with the computer system causes or programs computer system 900 to be a special-purpose machine. According to one embodiment, the techniques herein are performed by computer system 900 in response to processor 904 executing one or more sequences of one or more instructions contained in main memory 906. Such instructions may be read into main memory 906 from another storage medium, such as storage device 910. Execution of the sequences of instructions contained in main memory 906 causes processor 904 to perform the process steps described herein. In alternative embodiments, hard-wired circuitry may be used in place of or in combination with software instructions.

[0168] The term "storage media" as used herein refers to any non-transitory media that store data and/or instructions that cause a machine to operation in a specific fashion. Such storage media may comprise non-volatile media and/or volatile media. Non-volatile media includes, for example, optical or magnetic disks, such as storage device 910. Volatile media includes dynamic memory, such as main memory 906. Common forms of storage media include, for example, a floppy disk, a flexible disk, hard disk, solid state drive, magnetic tape, or any other magnetic data storage medium, a CD-ROM, any other optical data storage medium, any physical medium with patterns of holes, a RAM, a PROM, and EPROM, a FLASH-EPROM, NVRAM, any other memory chip or cartridge.

[0169] Storage media is distinct from but may be used in conjunction with transmission media. Transmission media participates in transferring information between storage media. For example, transmission media includes coaxial cables, copper wire and fiber optics, including the wires that comprise bus 902. Transmission media can also take the form of acoustic or light waves, such as those generated during radio-wave and infra-red data communications.

[0170] Various forms of media may be involved in carrying one or more sequences of one or more instructions to processor 904 for execution. For example, the instructions may initially be carried on a magnetic disk or solid state drive of a remote computer. The remote computer can load the instructions into its dynamic memory and send the instructions over a telephone line using a modem. A modem local to computer system 900 can receive the data on the telephone line and use an infra-red transmitter to convert the data to an infra-red signal. An infra-red detector can receive the data carried in the infra-red signal and appropriate circuitry can place the data on bus 902. Bus 902 carries the data to main memory 906, from which processor 904 retrieves and executes the instructions. The instructions received by main memory 906 may optionally be stored on storage device 910 either before or after execution by processor 904.

[0171] Computer system 900 also includes a communication interface 918 coupled to bus 902.

Communication interface 918 provides a two-way data communication coupling to a network link 920 that is connected to a local network 922. For example, communication interface 918 may be an integrated services digital network (ISDN) card, cable modem, satellite modem, or a modem to provide a data communication connection to a corresponding type of telephone line. As another example, communication interface 918 may be a local area network (LAN) card to provide a data communication connection to a compatible LAN. Wireless links may also be implemented. In any such implementation, communication interface 918 sends and receives electrical, electromagnetic or optical signals that carry digital data streams representing various types of information.

[0172] Network link 920 typically provides data communication through one or more networks to other data devices. For example, network link 920 may provide a connection through local network 922 to a host computer 924 or to data equipment operated by an Internet Service Provider (ISP) 926. ISP 926 in turn provides data communication services through the world wide packet data communication network now commonly referred to as the "Internet" 928. Local network 922 and Internet 928 both use electrical, electromagnetic or optical signals that carry digital data streams. The signals through the various networks and the signals on network link 920 and through communication interface 918, which carry the digital data to and from computer system 900, are example forms of transmission media.

[0173] Computer system 900 can send messages and receive data, including program code, through the network(s), network link 920 and communication interface 918. In the Internet example, a server 930 might transmit a requested code for an application program through Internet 928, ISP 926, local network 922 and communication interface 918.

[0174] The received code may be executed by processor 904 as it is received, and/or stored in storage device 910, or other non-volatile storage for later execution.

[0175] The following Table 3 describes the calculation of the Perceptual Curve EOTF for converting digital video code values into absolute linear luminance levels at the point of display. Also included is the inverse OETF calculation for converting absolute linear luminance into digital code values.

Table 3. Exemplary Specification for Perceptual Curve EOTF

Exemplary Equation Definitions:	
D = Perceptual Curve digital code value, SDI-legal unsigned integer, 10 or 12 bits	
b = number of bits per component in digital signal representation, 10 or 12	
V = normalized Perceptual Curve signal value, $0 \leq V \leq 1$	
Y = normalized luminance value, $0 \leq Y \leq 1$	
L = absolute luminance value, $0 \leq L \leq 10,000 \text{ cd/m}^2$	

Exemplary EOTF Decode Equations:	
$V = \frac{D - 4 \cdot 2^{b-10}}{1015 \cdot 2^{b-10}}$	
$Y = \left(\frac{\max \left[\left(V^{1/m} - c_1 \right), 0 \right]}{c_2 - c_3 V^{1/m}} \right)^{1/n}$	
$L = 10,000 - Y$	
Exemplary OETF Encode Equations:	
$Y = \frac{L}{10,000}$	
$V = \left(\frac{c_1 + c_2 Y^n}{1 + c_3 Y^n} \right)^m$	
$D = \text{INT}(1015 \cdot V \cdot 2^{b-10}) + 4 \cdot 2^{b-10}$	
Exemplary Constants:	
	$n = \frac{2610}{4096} \times \frac{1}{4} \approx 0.15930176$
	$m = \frac{2523}{4096} \times 128 = 78.84375$
	$c_1 = c_3 - c_2 + 1 = \frac{3424}{4096} = 0.8359375$
	$c_2 = \frac{2413}{4096} \times 32 = 18.8515625$
	$c_3 = \frac{2392}{4096} \times 32 = 18.6875$
Notes:	
1. The operator INT returns the value of 0 for fractional parts in the range of 0 to 0.4999... and +1 for fractional parts in the range of 0.5 to 0.9999..., i.e. it rounds up fractions above 0.5.	
2. All constants are defined as exact multiples of 12 bit rationals to avoid rounding concerns.	
3. R, G, or B signal components are to be computed in the same way as the Y signal component described above.	

[0176] The following Table 4 shows exemplary values for 10 bits.

Table 4. Exemplary Table of Values for 10 bits

D	V	Y	L(cd/m ²)
0		<i>Reserved</i>	
1		<i>Reserved</i>	
2		<i>Reserved</i>	
3		<i>Reserved</i>	
4	0.00000	0.000 E+00	0.00000
5	0.00099	4.096E-09	0.00004
6	0.00197	1.329E-08	0.00013
7	0.00296	2.659E-08	0.00027
8	0.00394	4.374E-08	0.00044
9	0.00493	6.463E-08	0.00065
10	0.00591	8.922E-08	0.00089
11	0.00690	1.175E-07	0.00117
12	0.00788	1.495E-07	0.00149
13	0.00887	1.852E-07	0.00185
14	0.00985	2.248E-07	0.00225
15	0.01084	2.681E-07	0.00268
16	0.01182	3.154E-07	0.00315
17	0.01281	3.666E-07	0.00367
18	0.01379	4.219E-07	0.00422
19	0.01478	4.812E-07	0.00481
20	0.01576	5.447E-07	0.00545
21	0.01675	6.125E-07	0.00613
22	0.01773	6.846E-07	0.00685
23	0.01872	7.610E-07	0.00761
24	0.01970	8.420E-07	0.00842
25	0.02069	9.275E-07	0.00927
26	0.02167	1.018E-06	0.01018
27	0.02266	1.112E-06	0.01112
28	0.02365	1.212E-06	0.01212
29	0.02463	1.317E-06	0.01317
30	0.02562	1.426E-06	0.01426
31	0.02660	1.541E-06	0.01541

D	V	Y	L(cd/m ²)
32	0.02759	1.661E-06	0.01661
33	0.02857	1.786E-06	0.01786
34	0.02956	1.916E-06	0.01916
35	0.03054	2.052E-06	0.02052
36	0.03153	2.193E-06	0.02193
37	0.03251	2.340E-06	0.02340
38	0.03350	2.493E-06	0.02493
39	0.03448	2.652E-06	0.02652
40	0.03547	2.816E-06	0.02816
41	0.03645	2.987E-06	0.02987
42	0.03744	3.163E-06	0.03163
43	0.03842	3.346E-06	0.03346
44	0.03941	3.536E-06	0.03536
45	0.04039	3.731E-06	0.03731
46	0.04138	3.934E-06	0.03934
47	0.04236	4.143E-06	0.04143
48	0.04335	4.358E-06	0.04358
49	0.04433	4.581E-06	0.04581
50	0.04532	4.810E-06	0.04810
51	0.04631	5.047E-06	0.05047
52	0.04729	5.291E-06	0.05291
53	0.04828	5.542E-06	0.05542
54	0.04926	5.801E-06	0.05801
55	0.05025	6.067E-06	0.06067
56	0.05123	6.341E-06	0.06341
57	0.05222	6.623E-06	0.06623
58	0.05320	6.913E-06	0.06913
59	0.05419	7.211E-06	0.07211
60	0.05517	7.517E-06	0.07517
61	0.05616	7.831E-06	0.07831
62	0.05714	8.154E-06	0.08154
63	0.05813	8.485E-06	0.08485
64	0.05911	8.825E-06	0.08825
65	0.06010	9.174E-06	0.09174

D	V	Y	L(cd/m ²)
66	0.06108	9.532E-06	0.09532
67	0.06207	9.899E-06	0.09899
68	0.06305	1.027E-05	0.10275
69	0.06404	1.066E-05	0.10660
70	0.06502	1.106E-05	0.11055
71	0.06601	1.146E-05	0.11460
72	0.06700	1.187E-05	0.11874
73	0.06798	1.230E-05	0.12298
74	0.06897	1.273E-05	0.12733
75	0.06995	1.318E-05	0.13177
76	0.07094	1.363E-05	0.13632
77	0.07192	1.410E-05	0.14097
78	0.07291	1.457E-05	0.14573
79	0.07389	1.506E-05	0.15060
80	0.07488	1.556E-05	0.15558
81	0.07586	1.607E-05	0.16067
82	0.07685	1.659E-05	0.16587
83	0.07783	1.712E-05	0.17119
84	0.07882	1.766E-05	0.17662
85	0.07980	1.822E-05	0.18217
86	0.08079	1.878E-05	0.18783
87	0.08177	1.936E-05	0.19362
88	0.08276	1.995E-05	0.19953
89	0.08374	2.056E-05	0.20556
90	0.08473	2.117E-05	0.21172
91	0.08571	2.180E-05	0.21801
92	0.08670	2.244E-05	0.22443
93	0.08768	2.310E-05	0.23097
94	0.08867	2.377E-05	0.23765
95	0.08966	2.445E-05	0.24447
96	0.09064	2.514E-05	0.25142
97	0.09163	2.585E-05	0.25850
98	0.09261	2.657E-05	0.26573
99	0.09360	2.731E-05	0.27310

D	V	Y	L(cd/m ²)
100	0.09458	2.806E-05	0.28061
101	0.09557	2.883E-05	0.28826
102	0.09655	2.961E-05	0.29607
103	0.09754	3.040E-05	0.30402
104	0.09852	3.121E-05	0.31212
105	0.09951	3.204E-05	0.32038
106	0.10049	3.288E-05	0.32879
107	0.10148	3.374E-05	0.33736
108	0.10246	3.461E-05	0.34608
109	0.10345	3.550E-05	0.35497
110	0.10443	3.640E-05	0.36402
111	0.10542	3.732E-05	0.37324
112	0.10640	3.826E-05	0.38262
113	0.10739	3.922E-05	0.39217
114	0.10837	4.019E-05	0.40189
115	0.10936	4.118E-05	0.41179
116	0.11034	4.219E-05	0.42186
117	0.11133	4.321E-05	0.43211
118	0.11232	4.425E-05	0.44254
119	0.11330	4.531E-05	0.45315
120	0.11429	4.639E-05	0.46394
121	0.11527	4.749E-05	0.47492
122	0.11626	4.861E-05	0.48609
123	0.11724	4.975E-05	0.49746
124	0.11823	5.090E-05	0.50901
125	0.11921	5.208E-05	0.52076
126	0.12020	5.327E-05	0.53271
127	0.12118	5.449E-05	0.54486
128	0.12217	5.572E-05	0.55722
129	0.12315	5.698E-05	0.56978
130	0.12414	5.825E-05	0.58255
131	0.12512	5.955E-05	0.59552
132	0.12611	6.087E-05	0.60872
133	0.12709	6.221E-05	0.62212

D	V	Y	L(cd/m ²)
134	0.12808	6.357E-05	0.63575
135	0.12906	6.496E-05	0.64959
136	0.13005	6.637E-05	0.66366
137	0.13103	6.780E-05	0.67796
138	0.13202	6.925E-05	0.69248
139	0.13300	7.072E-05	0.70724
140	0.13399	7.222E-05	0.72223
141	0.13498	7.375E-05	0.73746
142	0.13596	7.529E-05	0.75292
143	0.13695	7.686E-05	0.76863
144	0.13793	7.846E-05	0.78458
145	0.13892	8.008E-05	0.80079
146	0.13990	8.172E-05	0.81724
147	0.14089	8.339E-05	0.83395
148	0.14187	8.509E-05	0.85091
149	0.14286	8.681E-05	0.86814
150	0.14384	8.856E-05	0.88562
151	0.14483	9.034E-05	0.90338
152	0.14581	9.214E-05	0.92140
153	0.14680	9.397E-05	0.93969
154	0.14778	9.583E-05	0.95826
155	0.14877	9.771E-05	0.97711
156	0.14975	9.962E-05	0.99624
157	0.15074	1.016E-04	1.01565
158	0.15172	1.035E-04	1.03535
159	0.15271	1.055E-04	1.05534
160	0.15369	1.076E-04	1.07563
161	0.15468	1.096E-04	1.09622
162	0.15567	1.117E-04	1.11710
163	0.15665	1.138E-04	1.13829
164	0.15764	1.160E-04	1.15979
165	0.15862	1.182E-04	1.18160
166	0.15961	1.204E-04	1.20372
167	0.16059	1.226E-04	1.22616

D	V	Y	L(cd/m ²)
168	0.16158	1.249E-04	1.24892
169	0.16256	1.272E-04	1.27201
170	0.16355	1.295E-04	1.29543
171	0.16453	1.319E-04	1.31918
172	0.16552	1.343E-04	1.34326
173	0.16650	1.368E-04	1.36769
174	0.16749	1.392E-04	1.39246
175	0.16847	1.418E-04	1.41758
176	0.16946	1.443E-04	1.44304
177	0.17044	1.469E-04	1.46887
178	0.17143	1.495E-04	1.49505
179	0.17241	1.522E-04	1.52160
180	0.17340	1.549E-04	1.54851
181	0.17438	1.576E-04	1.57579
182	0.17537	1.603E-04	1.60345
183	0.17635	1.631E-04	1.63148
184	0.17734	1.660E-04	1.65990
185	0.17833	1.689E-04	1.68871
186	0.17931	1.718E-04	1.71791
187	0.18030	1.748E-04	1.74750
188	0.18128	1.777E-04	1.77749
189	0.18227	1.808E-04	1.80789
190	0.18325	1.839E-04	1.83870
191	0.18424	1.870E-04	1.86991
192	0.18522	1.902E-04	1.90155
193	0.18621	1.934E-04	1.93361
194	0.18719	1.966E-04	1.96609
195	0.18818	1.999E-04	1.99900
196	0.18916	2.032E-04	2.03235
197	0.19015	2.066E-04	2.06614
198	0.19113	2.100E-04	2.10037
199	0.19212	2.135E-04	2.13506
200	0.19310	2.170E-04	2.17019
201	0.19409	2.206E-04	2.20579

D	V	Y	L(cd/m ²)
202	0.19507	2.242E-04	2.24185
203	0.19606	2.278E-04	2.27837
204	0.19704	2.315E-04	2.31537
205	0.19803	2.353E-04	2.35285
206	0.19901	2.391E-04	2.39081
207	0.20000	2.429E-04	2.42926
208	0.20099	2.468E-04	2.46821
209	0.20197	2.508E-04	2.50765
210	0.20296	2.548E-04	2.54760
211	0.20394	2.588E-04	2.58805
212	0.20493	2.629E-04	2.62902
213	0.20591	2.671E-04	2.67051
214	0.20690	2.713E-04	2.71252
215	0.20788	2.755E-04	2.75507
216	0.20887	2.798E-04	2.79815
217	0.20985	2.842E-04	2.84177
218	0.21084	2.886E-04	2.88594
219	0.21182	2.931E-04	2.93066
220	0.21281	2.976E-04	2.97594
221	0.21379	3.022E-04	3.02179
222	0.21478	3.068E-04	3.06820
223	0.21576	3.115E-04	3.11519
224	0.21675	3.163E-04	3.16276
225	0.21773	3.211E-04	3.21092
226	0.21872	3.260E-04	3.25967
227	0.21970	3.309E-04	3.30903
228	0.22069	3.359E-04	3.35898
229	0.22167	3.410E-04	3.40955
230	0.22266	3.461E-04	3.46074
231	0.22365	3.513E-04	3.51255
232	0.22463	3.565E-04	3.56500
233	0.22562	3.618E-04	3.61808
234	0.22660	3.672E-04	3.67180
235	0.22759	3.726E-04	3.72618

D	V	Y	L(cd/m ²)
236	0.22857	3.781E-04	3.78121
237	0.22956	3.837E-04	3.83690
238	0.23054	3.893E-04	3.89327
239	0.23153	3.950E-04	3.95031
240	0.23251	4.008E-04	4.00803
241	0.23350	4.066E-04	4.06645
242	0.23448	4.126E-04	4.12556
243	0.23547	4.185E-04	4.18537
244	0.23645	4.246E-04	4.24590
245	0.23744	4.307E-04	4.30715
246	0.23842	4.369E-04	4.36912
247	0.23941	4.432E-04	4.43182
248	0.24039	4.495E-04	4.49527
249	0.24138	4.559E-04	4.55946
250	0.24236	4.624E-04	4.62440
251	0.24335	4.690E-04	4.69011
252	0.24433	4.757E-04	4.75659
253	0.24532	4.824E-04	4.82385
254	0.24631	4.892E-04	4.89189
255	0.24729	4.961E-04	4.96073
256	0.24828	5.030E-04	5.03036
257	0.24926	5.101E-04	5.10081
258	0.25025	5.172E-04	5.17207
259	0.25123	5.244E-04	5.24416
260	0.25222	5.317E-04	5.31707
261	0.25320	5.391E-04	5.39084
262	0.25419	5.465E-04	5.46545
263	0.25517	5.541E-04	5.54091
264	0.25616	5.617E-04	5.61725
265	0.25714	5.694E-04	5.69446
266	0.25813	5.773E-04	5.77255
267	0.25911	5.852E-04	5.85153
268	0.26010	5.931E-04	5.93142
269	0.26108	6.012E-04	6.01221

D	V	Y	L(cd/m ²)
270	0.26207	6.094E-04	6.09393
271	0.26305	6.177E-04	6.17657
272	0.26404	6.260E-04	6.26014
273	0.26502	6.345E-04	6.34467
274	0.26601	6.430E-04	6.43014
275	0.26700	6.517E-04	6.51658
276	0.26798	6.604E-04	6.60400
277	0.26897	6.692E-04	6.69239
278	0.26995	6.782E-04	6.78178
279	0.27094	6.872E-04	6.87217
280	0.27192	6.964E-04	6.96357
281	0.27291	7.056E-04	7.05600
282	0.27389	7.149E-04	7.14945
283	0.27488	7.244E-04	7.24395
284	0.27586	7.339E-04	7.33949
285	0.27685	7.436E-04	7.43610
286	0.27783	7.534E-04	7.53378
287	0.27882	7.633E-04	7.63254
288	0.27980	7.732E-04	7.73240
289	0.28079	7.833E-04	7.83335
290	0.28177	7.935E-04	7.93542
291	0.28276	8.039E-04	8.03862
292	0.28374	8.143E-04	8.14295
293	0.28473	8.248E-04	8.24842
294	0.28571	8.355E-04	8.35505
295	0.28670	8.463E-04	8.46285
296	0.28768	8.572E-04	8.57183
297	0.28867	8.682E-04	8.68200
298	0.28966	8.793E-04	8.79337
299	0.29064	8.906E-04	8.90595
300	0.29163	9.020E-04	9.01976
301	0.29261	9.135E-04	9.13480
302	0.29360	9.251E-04	9.25109
303	0.29458	9.369E-04	9.36864

D	V	Y	L(cd/m ²)
304	0.29557	9.487E-04	9.48746
305	0.29655	9.608E-04	9.60757
306	0.29754	9.729E-04	9.72897
307	0.29852	9.852E-04	9.85168
308	0.29951	9.976E-04	9.97571
309	0.30049	1.010E-03	10.10108
310	0.30148	1.023E-03	10.22779
311	0.30246	1.036E-03	10.35585
312	0.30345	1.049E-03	10.48529
313	0.30443	1.062E-03	10.61612
314	0.30542	1.075E-03	10.74834
315	0.30640	1.088E-03	10.88197
316	0.30739	1.102E-03	11.01703
317	0.30837	1.115E-03	11.15352
318	0.30936	1.129E-03	11.29147
319	0.31034	1.143E-03	11.43087
320	0.31133	1.157E-03	11.57176
321	0.31232	1.171E-03	11.71414
322	0.31330	1.186E-03	11.85803
323	0.31429	1.200E-03	12.00343
324	0.31527	1.215E-03	12.15037
325	0.31626	1.230E-03	12.29886
326	0.31724	1.245E-03	12.44891
327	0.31823	1.260E-03	12.60054
328	0.31921	1.275E-03	12.75376
329	0.32020	1.291E-03	12.90859
330	0.32118	1.307E-03	13.06505
331	0.32217	1.322E-03	13.22314
332	0.32315	1.338E-03	13.38288
333	0.32414	1.354E-03	13.54430
334	0.32512	1.371E-03	13.70739
335	0.32611	1.387E-03	13.87219
336	0.32709	1.404E-03	14.03870
337	0.32808	1.421E-03	14.20695

D	V	Y	L(cd/m ²)
338	0.32906	1.438E-03	14.37694
339	0.33005	1.455E-03	14.54869
340	0.33103	1.472E-03	14.72223
341	0.33202	1.490E-03	14.89756
342	0.33300	1.507E-03	15.07471
343	0.33399	1.525E-03	15.25369
344	0.33498	1.543E-03	15.43451
345	0.33596	1.562E-03	15.61720
346	0.33695	1.580E-03	15.80177
347	0.33793	1.599E-03	15.98824
348	0.33892	1.618E-03	16.17663
349	0.33990	1.637E-03	16.36695
350	0.34089	1.656E-03	16.55922
351	0.34187	1.675E-03	16.75346
352	0.34286	1.695E-03	16.94970
353	0.34384	1.715E-03	17.14794
354	0.34483	1.735E-03	17.34820
355	0.34581	1.755E-03	17.55051
356	0.34680	1.775E-03	17.75488
357	0.34778	1.796E-03	17.96133
358	0.34877	1.817E-03	18.16989
359	0.34975	1.838E-03	18.38056
360	0.35074	1.859E-03	18.59338
361	0.35172	1.881E-03	18.80835
362	0.35271	1.903E-03	19.02551
363	0.35369	1.924E-03	19.24486
364	0.35468	1.947E-03	19.46644
365	0.35567	1.969E-03	19.69025
366	0.35665	1.992E-03	19.91632
367	0.35764	2.014E-03	20.14468
368	0.35862	2.038E-03	20.37534
369	0.35961	2.061E-03	20.60832
370	0.36059	2.084E-03	20.84364
371	0.36158	2.108E-03	21.08134

D	V	Y	L(cd/m ²)
372	0.36256	2.132E-03	21.32141
373	0.36355	2.156E-03	21.56390
374	0.36453	2.181E-03	21.80882
375	0.36552	2.206E-03	22.05620
376	0.36650	2.231E-03	22.30605
377	0.36749	2.256E-03	22.55840
378	0.36847	2.281E-03	22.81327
379	0.36946	2.307E-03	23.07068
380	0.37044	2.333E-03	23.33067
381	0.37143	2.359E-03	23.59324
382	0.37241	2.386E-03	23.85843
383	0.37340	2.413E-03	24.12626
384	0.37438	2.440E-03	24.39674
385	0.37537	2.467E-03	24.66992
386	0.37635	2.495E-03	24.94581
387	0.37734	2.522E-03	25.22443
388	0.37833	2.551E-03	25.50582
389	0.37931	2.579E-03	25.78999
390	0.38030	2.608E-03	26.07697
391	0.38128	2.637E-03	26.36679
392	0.38227	2.666E-03	26.65947
393	0.38325	2.696E-03	26.95504
394	0.38424	2.725E-03	27.25352
395	0.38522	2.755E-03	27.55495
396	0.38621	2.786E-03	27.85934
397	0.38719	2.817E-03	28.16672
398	0.38818	2.848E-03	28.47713
399	0.38916	2.879E-03	28.79059
400	0.39015	2.911E-03	29.10712
401	0.39113	2.943E-03	29.42676
402	0.39212	2.975E-03	29.74953
403	0.39310	3.008E-03	30.07546
404	0.39409	3.040E-03	30.40459
405	0.39507	3.074E-03	30.73692

D	V	Y	L(cd/m ²)
406	0.39606	3.107E-03	31.07251
407	0.39704	3.141E-03	31.41137
408	0.39803	3.175E-03	31.75354
409	0.39901	3.210E-03	32.09905
410	0.40000	3.245E-03	32.44792
411	0.40099	3.280E-03	32.80018
412	0.40197	3.316E-03	33.15588
413	0.40296	3.352E-03	33.51503
414	0.40394	3.388E-03	33.87767
415	0.40493	3.424E-03	34.24383
416	0.40591	3.461E-03	34.61355
417	0.40690	3.499E-03	34.98684
418	0.40788	3.536E-03	35.36376
419	0.40887	3.574E-03	35.74432
420	0.40985	3.613E-03	36.12857
421	0.41084	3.652E-03	36.51652
422	0.41182	3.691E-03	36.90823
423	0.41281	3.730E-03	37.30372
424	0.41379	3.770E-03	37.70303
425	0.41478	3.811E-03	38.10618
426	0.41576	3.851E-03	38.51322
427	0.41675	3.892E-03	38.92418
428	0.41773	3.934E-03	39.33909
429	0.41872	3.976E-03	39.75800
430	0.41970	4.018E-03	40.18093
431	0.42069	4.061E-03	40.60792
432	0.42167	4.104E-03	41.03901
433	0.42266	4.147E-03	41.47423
434	0.42365	4.191E-03	41.91363
435	0.42463	4.236E-03	42.35723
436	0.42562	4.281E-03	42.80509
437	0.42660	4.326E-03	43.25723
438	0.42759	4.371E-03	43.71369
439	0.42857	4.417E-03	44.17451

D	V	Y	L(cd/m ²)
440	0.42956	4.464E-03	44.63974
441	0.43054	4.511E-03	45.10941
442	0.43153	4.558E-03	45.58355
443	0.43251	4.606E-03	46.06222
444	0.43350	4.655E-03	46.54545
445	0.43448	4.703E-03	47.03328
446	0.43547	4.753E-03	47.52575
447	0.43645	4.802E-03	48.02291
448	0.43744	4.852E-03	48.52479
449	0.43842	4.903E-03	49.03144
450	0.43941	4.954E-03	49.54290
451	0.44039	5.006E-03	50.05921
452	0.44138	5.058E-03	50.58042
453	0.44236	5.111E-03	51.10657
454	0.44335	5.164E-03	51.63771
455	0.44433	5.217E-03	52.17387
456	0.44532	5.272E-03	52.71511
457	0.44631	5.326E-03	53.26147
458	0.44729	5.381E-03	53.81299
459	0.44828	5.437E-03	54.36973
460	0.44926	5.493E-03	54.93172
461	0.45025	5.550E-03	55.49901
462	0.45123	5.607E-03	56.07166
463	0.45222	5.665E-03	56.64970
464	0.45320	5.723E-03	57.23319
465	0.45419	5.782E-03	57.82218
466	0.45517	5.842E-03	58.41671
467	0.45616	5.902E-03	59.01683
468	0.45714	5.962E-03	59.62260
469	0.45813	6.023E-03	60.23406
470	0.45911	6.085E-03	60.85126
471	0.46010	6.147E-03	61.47426
472	0.46108	6.210E-03	62.10311
473	0.46207	6.274E-03	62.73785

D	V	Y	L(cd/m ²)
474	0.46305	6.338E-03	63.37855
475	0.46404	6.403E-03	64.02525
476	0.46502	6.468E-03	64.67801
477	0.46601	6.534E-03	65.33688
478	0.46700	6.600E-03	66.00191
479	0.46798	6.667E-03	66.67316
480	0.46897	6.735E-03	67.35069
481	0.46995	6.803E-03	68.03455
482	0.47094	6.872E-03	68.72480
483	0.47192	6.942E-03	69.42149
484	0.47291	7.012E-03	70.12468
485	0.47389	7.083E-03	70.83443
486	0.47488	7.155E-03	71.55079
487	0.47586	7.227E-03	72.27383
488	0.47685	7.300E-03	73.00361
489	0.47783	7.374E-03	73.74018
490	0.47882	7.448E-03	74.48361
491	0.47980	7.523E-03	75.23395
492	0.48079	7.599E-03	75.99127
493	0.48177	7.676E-03	76.75562
494	0.48276	7.753E-03	77.52708
495	0.48374	7.831E-03	78.30570
496	0.48473	7.909E-03	79.09155
497	0.48571	7.988E-03	79.88469
498	0.48670	8.069E-03	80.68519
499	0.48768	8.149E-03	81.49310
500	0.48867	8.231E-03	82.30851
501	0.48966	8.313E-03	83.13146
502	0.49064	8.396E-03	83.96204
503	0.49163	8.480E-03	84.80031
504	0.49261	8.565E-03	85.64633
505	0.49360	8.650E-03	86.50017
506	0.49458	8.736E-03	87.36191
507	0.49557	8.823E-03	88.23161

D	V	Y	L(cd/m ²)
508	0.49655	8.911E-03	89.10934
509	0.49754	9.000E-03	89.99518
510	0.49852	9.089E-03	90.88920
511	0.49951	9.179E-03	91.79146
512	0.50049	9.270E-03	92.70205
513	0.50148	9.362E-03	93.62103
514	0.50246	9.455E-03	94.54848
515	0.50345	9.548E-03	95.48448
516	0.50443	9.643E-03	96.42909
517	0.50542	9.738E-03	97.38241
518	0.50640	9.834E-03	98.34449
519	0.50739	9.932E-03	99.31543
520	0.50837	1.003E-02	100.29530
521	0.50936	1.013E-02	101.28417
522	0.51034	1.023E-02	102.28213
523	0.51133	1.033E-02	103.28927
524	0.51232	1.043E-02	104.30565
525	0.51330	1.053E-02	105.33136
526	0.51429	1.064E-02	106.36648
527	0.51527	1.074E-02	107.41110
528	0.51626	1.085E-02	108.46530
529	0.51724	1.095E-02	109.52917
530	0.51823	1.106E-02	110.60279
531	0.51921	1.117E-02	111.68624
532	0.52020	1.128E-02	112.77962
533	0.52118	1.139E-02	113.88301
534	0.52217	1.150E-02	114.99650
535	0.52315	1.161E-02	116.12018
536	0.52414	1.173E-02	117.25414
537	0.52512	1.184E-02	118.39847
538	0.52611	1.196E-02	119.55326
539	0.52709	1.207E-02	120.71860
540	0.52808	1.219E-02	121.89459
541	0.52906	1.231E-02	123.08132

D	V	Y	L(cd/m ²)
542	0.53005	1.243E-02	124.27889
543	0.53103	1.255E-02	125.48739
544	0.53202	1.267E-02	126.70692
545	0.53300	1.279E-02	127.93758
546	0.53399	1.292E-02	129.17946
547	0.53498	1.304E-02	130.43266
548	0.53596	1.317E-02	131.69729
549	0.53695	1.330E-02	132.97344
550	0.53793	1.343E-02	134.26122
551	0.53892	1.356E-02	135.56073
552	0.53990	1.369E-02	136.87207
553	0.54089	1.382E-02	138.19535
554	0.54187	1.395E-02	139.53067
555	0.54286	1.409E-02	140.87814
556	0.54384	1.422E-02	142.23786
557	0.54483	1.436E-02	143.60995
558	0.54581	1.450E-02	144.99451
559	0.54680	1.464E-02	146.39166
560	0.54778	1.478E-02	147.80150
561	0.54877	1.492E-02	149.22415
562	0.54975	1.507E-02	150.65972
563	0.55074	1.521E-02	152.10833
564	0.55172	1.536E-02	153.57009
565	0.55271	1.550E-02	155.04511
566	0.55369	1.565E-02	156.53351
567	0.55468	1.580E-02	158.03542
568	0.55567	1.596E-02	159.55094
569	0.55665	1.611E-02	161.08021
570	0.55764	1.626E-02	162.62334
571	0.55862	1.642E-02	164.18046
572	0.55961	1.658E-02	165.75168
573	0.56059	1.673E-02	167.33714
574	0.56158	1.689E-02	168.93696
575	0.56256	1.706E-02	170.55126

D	V	Y	L(cd/m ²)
576	0.56355	1.722E-02	172.18018
577	0.56453	1.738E-02	173.82384
578	0.56552	1.755E-02	175.48237
579	0.56650	1.772E-02	177.15591
580	0.56749	1.788E-02	178.84459
581	0.56847	1.805E-02	180.54854
582	0.56946	1.823E-02	182.26789
583	0.57044	1.840E-02	184.00279
584	0.57143	1.858E-02	185.75337
585	0.57241	1.875E-02	187.51977
586	0.57340	1.893E-02	189.30212
587	0.57438	1.911E-02	191.10058
588	0.57537	1.929E-02	192.91528
589	0.57635	1.947E-02	194.74636
590	0.57734	1.966E-02	196.59398
591	0.57833	1.985E-02	198.45827
592	0.57931	2.003E-02	200.33939
593	0.58030	2.022E-02	202.23748
594	0.58128	2.042E-02	204.15270
595	0.58227	2.061E-02	206.08519
596	0.58325	2.080E-02	208.03511
597	0.58424	2.100E-02	210.00261
598	0.58522	2.120E-02	211.98785
599	0.58621	2.140E-02	213.99098
600	0.58719	2.160E-02	216.01217
601	0.58818	2.181E-02	218.05157
602	0.58916	2.201E-02	220.10935
603	0.59015	2.222E-02	222.18566
604	0.59113	2.243E-02	224.28067
605	0.59212	2.264E-02	226.39455
606	0.59310	2.285E-02	228.52747
607	0.59409	2.307E-02	230.67959
608	0.59507	2.329E-02	232.85108
609	0.59606	2.350E-02	235.04212

D	V	Y	L(cd/m ²)
610	0.59704	2.373E-02	237.25287
611	0.59803	2.395E-02	239.48352
612	0.59901	2.417E-02	241.73423
613	0.60000	2.440E-02	244.00519
614	0.60099	2.463E-02	246.29658
615	0.60197	2.486E-02	248.60857
616	0.60296	2.509E-02	250.94136
617	0.60394	2.533E-02	253.29512
618	0.60493	2.557E-02	255.67004
619	0.60591	2.581E-02	258.06630
620	0.60690	2.605E-02	260.48411
621	0.60788	2.629E-02	262.92364
622	0.60887	2.654E-02	265.38509
623	0.60985	2.679E-02	267.86866
624	0.61084	2.704E-02	270.37454
625	0.61182	2.729E-02	272.90293
626	0.61281	2.755E-02	275.45403
627	0.61379	2.780E-02	278.02804
628	0.61478	2.806E-02	280.62516
629	0.61576	2.832E-02	283.24561
630	0.61675	2.859E-02	285.88958
631	0.61773	2.886E-02	288.55729
632	0.61872	2.912E-02	291.24894
633	0.61970	2.940E-02	293.96476
634	0.62069	2.967E-02	296.70495
635	0.62167	2.995E-02	299.46973
636	0.62266	3.023E-02	302.25931
637	0.62365	3.051E-02	305.07393
638	0.62463	3.079E-02	307.91380
639	0.62562	3.108E-02	310.77915
640	0.62660	3.137E-02	313.67020
641	0.62759	3.166E-02	316.58719
642	0.62857	3.195E-02	319.53033
643	0.62956	3.225E-02	322.49987

D	V	Y	L(cd/m ²)
644	0.63054	3.255E-02	325.49605
645	0.63153	3.285E-02	328.51909
646	0.63251	3.316E-02	331.56923
647	0.63350	3.346E-02	334.64673
648	0.63448	3.378E-02	337.75181
649	0.63547	3.409E-02	340.88473
650	0.63645	3.440E-02	344.04574
651	0.63744	3.472E-02	347.23509
652	0.63842	3.505E-02	350.45302
653	0.63941	3.537E-02	353.69979
654	0.64039	3.570E-02	356.97566
655	0.64138	3.603E-02	360.28090
656	0.64236	3.636E-02	363.61575
657	0.64335	3.670E-02	366.98049
658	0.64433	3.704E-02	370.37537
659	0.64532	3.738E-02	373.80068
660	0.64631	3.773E-02	377.25668
661	0.64729	3.807E-02	380.74365
662	0.64828	3.843E-02	384.26186
663	0.64926	3.878E-02	387.81159
664	0.65025	3.914E-02	391.39312
665	0.65123	3.950E-02	395.00674
666	0.65222	3.987E-02	398.65273
667	0.65320	4.023E-02	402.33138
668	0.65419	4.060E-02	406.04299
669	0.65517	4.098E-02	409.78784
670	0.65616	4.136E-02	413.56624
671	0.65714	4.174E-02	417.37849
672	0.65813	4.212E-02	421.22488
673	0.65911	4.251E-02	425.10573
674	0.66010	4.290E-02	429.02134
675	0.66108	4.330E-02	432.97202
676	0.66207	4.370E-02	436.95808
677	0.66305	4.410E-02	440.97986

D	V	Y	L(cd/m ²)
678	0.66404	4.450E-02	445.03765
679	0.66502	4.491E-02	449.13179
680	0.66601	4.533E-02	453.26260
681	0.66700	4.574E-02	457.43041
682	0.66798	4.616E-02	461.63555
683	0.66897	4.659E-02	465.87835
684	0.66995	4.702E-02	470.15916
685	0.67094	4.745E-02	474.47831
686	0.67192	4.788E-02	478.83615
687	0.67291	4.832E-02	483.23302
688	0.67389	4.877E-02	487.66928
689	0.67488	4.921E-02	492.14528
690	0.67586	4.967E-02	496.66137
691	0.67685	5.012E-02	501.21792
692	0.67783	5.058E-02	505.81528
693	0.67882	5.105E-02	510.45383
694	0.67980	5.151E-02	515.13393
695	0.68079	5.199E-02	519.85596
696	0.68177	5.246E-02	524.62029
697	0.68276	5.294E-02	529.42731
698	0.68374	5.343E-02	534.27740
699	0.68473	5.392E-02	539.17094
700	0.68571	5.441E-02	544.10833
701	0.68670	5.491E-02	549.08996
702	0.68768	5.541E-02	554.11624
703	0.68867	5.592E-02	559.18755
704	0.68966	5.643E-02	564.30431
705	0.69064	5.695E-02	569.46692
706	0.69163	5.747E-02	574.67581
707	0.69261	5.799E-02	579.93138
708	0.69360	5.852E-02	585.23405
709	0.69458	5.906E-02	590.58426
710	0.69557	5.960E-02	595.98243
711	0.69655	6.014E-02	601.42899

D	V	Y	L(cd/m ²)
712	0.69754	6.069E-02	606.92438
713	0.69852	6.125E-02	612.46904
714	0.69951	6.181E-02	618.06341
715	0.70049	6.237E-02	623.70795
716	0.70148	6.294E-02	629.40310
717	0.70246	6.351E-02	635.14933
718	0.70345	6.409E-02	640.94709
719	0.70443	6.468E-02	646.79685
720	0.70542	6.527E-02	652.69908
721	0.70640	6.587E-02	658.65426
722	0.70739	6.647E-02	664.66286
723	0.70837	6.707E-02	670.72537
724	0.70936	6.768E-02	676.84228
725	0.71034	6.830E-02	683.01407
726	0.71133	6.892E-02	689.24124
727	0.71232	6.955E-02	695.52430
728	0.71330	7.019E-02	701.86376
729	0.71429	7.083E-02	708.26011
730	0.71527	7.147E-02	714.71389
731	0.71626	7.212E-02	721.22561
732	0.71724	7.278E-02	727.79579
733	0.71823	7.344E-02	734.42496
734	0.71921	7.411E-02	741.11367
735	0.72020	7.479E-02	747.86245
736	0.72118	7.547E-02	754.67184
737	0.72217	7.615E-02	761.54240
738	0.72315	7.685E-02	768.47469
739	0.72414	7.755E-02	775.46925
740	0.72512	7.825E-02	782.52667
741	0.72611	7.896E-02	789.64751
742	0.72709	7.968E-02	796.83234
743	0.72808	8.041E-02	804.08176
744	0.72906	8.114E-02	811.39634
745	0.73005	8.188E-02	818.77668

D	V	Y	L(cd/m ²)
746	0.73103	8.262E-02	826.22339
747	0.73202	8.337E-02	833.73706
748	0.73300	8.413E-02	841.31830
749	0.73399	8.490E-02	848.96773
750	0.73498	8.567E-02	856.68597
751	0.73596	8.645E-02	864.47366
752	0.73695	8.723E-02	872.33141
753	0.73793	8.803E-02	880.25988
754	0.73892	8.883E-02	888.25970
755	0.73990	8.963E-02	896.33154
756	0.74089	9.045E-02	904.47604
757	0.74187	9.127E-02	912.69387
758	0.74286	9.210E-02	920.98570
759	0.74384	9.294E-02	929.35220
760	0.74483	9.378E-02	937.79407
761	0.74581	9.463E-02	946.31199
762	0.74680	9.549E-02	954.90665
763	0.74778	9.636E-02	963.57876
764	0.74877	9.723E-02	972.32902
765	0.74975	9.812E-02	981.15816
766	0.75074	9.901E-02	990.06690
767	0.75172	9.991E-02	999.05595
768	0.75271	1.008E-01	1008.12607
769	0.75369	1.017E-01	1017.27800
770	0.75468	1.027E-01	1026.51247
771	0.75567	1.036E-01	1035.83026
772	0.75665	1.045E-01	1045.23213
773	0.75764	1.055E-01	1054.71885
774	0.75862	1.064E-01	1064.29119
775	0.75961	1.074E-01	1073.94996
776	0.76059	1.084E-01	1083.69593
777	0.76158	1.094E-01	1093.52991
778	0.76256	1.103E-01	1103.45271
779	0.76355	1.113E-01	1113.46516

D	V	Y	L(cd/m ²)
780	0.76453	1.124E-01	1123.56806
781	0.76552	1.134E-01	1133.76227
782	0.76650	1.144E-01	1144.04861
783	0.76749	1.154E-01	1154.42793
784	0.76847	1.165E-01	1164.90110
785	0.76946	1.175E-01	1175.46898
786	0.77044	1.186E-01	1186.13245
787	0.77143	1.197E-01	1196.89237
788	0.77241	1.208E-01	1207.74965
789	0.77340	1.219E-01	1218.70519
790	0.77438	1.230E-01	1229.75989
791	0.77537	1.241E-01	1240.91466
792	0.77635	1.252E-01	1252.17044
793	0.77734	1.264E-01	1263.52815
794	0.77833	1.275E-01	1274.98874
795	0.77931	1.287E-01	1286.55317
796	0.78030	1.298E-01	1298.22238
797	0.78128	1.310E-01	1309.99736
798	0.78227	1.322E-01	1321.87908
799	0.78325	1.334E-01	1333.86853
800	0.78424	1.346E-01	1345.96672
801	0.78522	1.358E-01	1358.17464
802	0.78621	1.370E-01	1370.49332
803	0.78719	1.383E-01	1382.92378
804	0.78818	1.395E-01	1395.46706
805	0.78916	1.408E-01	1408.12422
806	0.79015	1.421E-01	1420.89630
807	0.79113	1.434E-01	1433.78438
808	0.79212	1.447E-01	1446.78954
809	0.79310	1.460E-01	1459.91285
810	0.79409	1.473E-01	1473.15543
811	0.79507	1.487E-01	1486.51839
812	0.79606	1.500E-01	1500.00283
813	0.79704	1.514E-01	1513.60991

D	V	Y	L(cd/m ²)
814	0.79803	1.527E-01	1527.34075
815	0.79901	1.541E-01	1541.19651
816	0.80000	1.555E-01	1555.17836
817	0.80099	1.569E-01	1569.28748
818	0.80197	1.584E-01	1583.52505
819	0.80296	1.598E-01	1597.89226
820	0.80394	1.612E-01	1612.39034
821	0.80493	1.627E-01	1627.02051
822	0.80591	1.642E-01	1641.78399
823	0.80690	1.657E-01	1656.68205
824	0.80788	1.672E-01	1671.71592
825	0.80887	1.687E-01	1686.88689
826	0.80985	1.702E-01	1702.19625
827	0.81084	1.718E-01	1717.64528
828	0.81182	1.733E-01	1733.23529
829	0.81281	1.749E-01	1748.96761
830	0.81379	1.765E-01	1764.84357
831	0.81478	1.781E-01	1780.86453
832	0.81576	1.797E-01	1797.03183
833	0.81675	1.813E-01	1813.34685
834	0.81773	1.830E-01	1829.81099
835	0.81872	1.846E-01	1846.42564
836	0.81970	1.863E-01	1863.19222
837	0.82069	1.880E-01	1880.11216
838	0.82167	1.897E-01	1897.18689
839	0.82266	1.914E-01	1914.41788
840	0.82365	1.932E-01	1931.80660
841	0.82463	1.949E-01	1949.35454
842	0.82562	1.967E-01	1967.06319
843	0.82660	1.985E-01	1984.93407
844	0.82759	2.003E-01	2002.96871
845	0.82857	2.021E-01	2021.16866
846	0.82956	2.040E-01	2039.53547
847	0.83054	2.058E-01	2058.07072

D	V	Y	L(cd/m ²)
848	0.83153	2.077E-01	2076.77601
849	0.83251	2.096E-01	2095.65294
850	0.83350	2.115E-01	2114.70314
851	0.83448	2.134E-01	2133.92824
852	0.83547	2.153E-01	2153.32990
853	0.83645	2.173E-01	2172.90979
854	0.83744	2.193E-01	2192.66960
855	0.83842	2.213E-01	2212.61104
856	0.83941	2.233E-01	2232.73582
857	0.84039	2.253E-01	2253.04569
858	0.84138	2.274E-01	2273.54240
859	0.84236	2.294E-01	2294.22773
860	0.84335	2.315E-01	2315.10346
861	0.84433	2.336E-01	2336.17142
862	0.84532	2.357E-01	2357.43342
863	0.84631	2.379E-01	2378.89131
864	0.84729	2.401E-01	2400.54696
865	0.84828	2.422E-01	2422.40224
866	0.84926	2.444E-01	2444.45906
867	0.85025	2.467E-01	2466.71934
868	0.85123	2.489E-01	2489.18502
869	0.85222	2.512E-01	2511.85806
870	0.85320	2.535E-01	2534.74043
871	0.85419	2.558E-01	2557.83414
872	0.85517	2.581E-01	2581.14120
873	0.85616	2.605E-01	2604.66365
874	0.85714	2.628E-01	2628.40356
875	0.85813	2.652E-01	2652.36299
876	0.85911	2.677E-01	2676.54405
877	0.86010	2.701E-01	2700.94886
878	0.86108	2.726E-01	2725.57957
879	0.86207	2.750E-01	2750.43834
880	0.86305	2.776E-01	2775.52735
881	0.86404	2.801E-01	2800.84881

D	V	Y	L(cd/m ²)
882	0.86502	2.826E-01	2826.40496
883	0.86601	2.852E-01	2852.19805
884	0.86700	2.878E-01	2878.23034
885	0.86798	2.905E-01	2904.50415
886	0.86897	2.931E-01	2931.02179
887	0.86995	2.958E-01	2957.78560
888	0.87094	2.985E-01	2984.79796
889	0.87192	3.012E-01	3012.06126
890	0.87291	3.040E-01	3039.57792
891	0.87389	3.067E-01	3067.35037
892	0.87488	3.095E-01	3095.38108
893	0.87586	3.124E-01	3123.67255
894	0.87685	3.152E-01	3152.22729
895	0.87783	3.181E-01	3181.04784
896	0.87882	3.210E-01	3210.13677
897	0.87980	3.239E-01	3239.49668
898	0.88079	3.269E-01	3269.13018
899	0.88177	3.299E-01	3299.03992
900	0.88276	3.329E-01	3329.22857
901	0.88374	3.360E-01	3359.69884
902	0.88473	3.390E-01	3390.45346
903	0.88571	3.421E-01	3421.49517
904	0.88670	3.453E-01	3452.82676
905	0.88768	3.484E-01	3484.45106
906	0.88867	3.516E-01	3516.37089
907	0.88966	3.549E-01	3548.58913
908	0.89064	3.581E-01	3581.10868
909	0.89163	3.614E-01	3613.93247
910	0.89261	3.647E-01	3647.06346
911	0.89360	3.681E-01	3680.50463
912	0.89458	3.714E-01	3714.25901
913	0.89557	3.748E-01	3748.32965
914	0.89655	3.783E-01	3782.71964
915	0.89754	3.817E-01	3817.43208

D	V	Y	L(cd/m ²)
916	0.89852	3.852E-01	3852.47012
917	0.89951	3.888E-01	3887.83695
918	0.90049	3.924E-01	3923.53576
919	0.90148	3.960E-01	3959.56982
920	0.90246	3.996E-01	3995.94239
921	0.90345	4.033E-01	4032.65679
922	0.90443	4.070E-01	4069.71636
923	0.90542	4.107E-01	4107.12448
924	0.90640	4.145E-01	4144.88457
925	0.90739	4.183E-01	4183.00009
926	0.90837	4.221E-01	4221.47450
927	0.90936	4.260E-01	4260.31135
928	0.91034	4.300E-01	4299.51418
929	0.91133	4.339E-01	4339.08659
930	0.91232	4.379E-01	4379.03221
931	0.91330	4.419E-01	4419.35473
932	0.91429	4.460E-01	4460.05783
933	0.91527	4.501E-01	4501.14528
934	0.91626	4.543E-01	4542.62085
935	0.91724	4.584E-01	4584.48837
936	0.91823	4.627E-01	4626.75172
937	0.91921	4.669E-01	4669.41478
938	0.92020	4.712E-01	4712.48152
939	0.92118	4.756E-01	4755.95591
940	0.92217	4.800E-01	4799.84198
941	0.92315	4.844E-01	4844.14381
942	0.92414	4.889E-01	4888.86551
943	0.92512	4.934E-01	4934.01124
944	0.92611	4.980E-01	4979.58519
945	0.92709	5.026E-01	5025.59161
946	0.92808	5.072E-01	5072.03478
947	0.92906	5.119E-01	5118.91905
948	0.93005	5.166E-01	5166.24879
949	0.93103	5.214E-01	5214.02842

D	V	Y	L(cd/m ²)
950	0.93202	5.262E-01	5262.26241
951	0.93300	5.311E-01	5310.95529
952	0.93399	5.360E-01	5360.11161
953	0.93498	5.410E-01	5409.73600
954	0.93596	5.460E-01	5459.83311
955	0.93695	5.510E-01	5510.40765
956	0.93793	5.561E-01	5561.46439
957	0.93892	5.613E-01	5613.00814
958	0.93990	5.665E-01	5665.04375
959	0.94089	5.718E-01	5717.57614
960	0.94187	5.771E-01	5770.61028
961	0.94286	5.824E-01	5824.15118
962	0.94384	5.878E-01	5878.20392
963	0.94483	5.933E-01	5932.77361
964	0.94581	5.988E-01	5987.86545
965	0.94680	6.043E-01	6043.48465
966	0.94778	6.100E-01	6099.63651
967	0.94877	6.156E-01	6156.32637
968	0.94975	6.214E-01	6213.55964
969	0.95074	6.271E-01	6271.34178
970	0.95172	6.330E-01	6329.67830
971	0.95271	6.389E-01	6388.57478
972	0.95369	6.448E-01	6448.03685
973	0.95468	6.508E-01	6508.07022
974	0.95567	6.569E-01	6568.68063
975	0.95665	6.630E-01	6629.87391
976	0.95764	6.692E-01	6691.65593
977	0.95862	6.754E-01	6754.03264
978	0.95961	6.817E-01	6817.01005
979	0.96059	6.881E-01	6880.59422
980	0.96158	6.945E-01	6944.79129
981	0.96256	7.010E-01	7009.60746
982	0.96355	7.075E-01	7075.04901
983	0.96453	7.141E-01	7141.12226

D	V	Y	L(cd/m ²)
984	0.96552	7.208E-01	7207.83362
985	0.96650	7.275E-01	7275.18956
986	0.96749	7.343E-01	7343.19663
987	0.96847	7.412E-01	7411.86143
988	0.96946	7.481E-01	7481.19065
989	0.97044	7.551E-01	7551.19105
990	0.97143	7.622E-01	7621.86945
991	0.97241	7.693E-01	7693.23276
992	0.97340	7.765E-01	7765.28795
993	0.97438	7.838E-01	7838.04207
994	0.97537	7.912E-01	7911.50226
995	0.97635	7.986E-01	7985.67571
996	0.97734	8.061E-01	8060.56972
997	0.97833	8.136E-01	8136.19165
998	0.97931	8.213E-01	8212.54893
999	0.98030	8.290E-01	8289.64909
1000	0.98128	8.367E-01	8367.49974
1001	0.98227	8.446E-01	8446.10856
1002	0.98325	8.525E-01	8525.48333
1003	0.98424	8.606E-01	8605.63189
1004	0.98522	8.687E-01	8686.56220
1005	0.98621	8.768E-01	8768.28228
1006	0.98719	8.851E-01	8850.80025
1007	0.98818	8.934E-01	8934.12431
1008	0.98916	9.018E-01	9018.26275
1009	0.99015	9.103E-01	9103.22396
1010	0.99113	9.189E-01	9189.01642
1011	0.99212	9.276E-01	9275.64869
1012	0.99310	9.363E-01	9363.12944
1013	0.99409	9.451E-01	9451.46742
1014	0.99507	9.541E-01	9540.67150
1015	0.99606	9.631E-01	9630.75061
1016	0.99704	9.722E-01	9721.71382
1017	0.99803	9.814E-01	9813.57027

D	V	Y	L(cd/m ²)
1018	0.99901	9.906E-01	9906.32922
1019	1.00000	1.000E+00	10000.00000
1020	<i>Reserved</i>		
1021	<i>Reserved</i>		
1022	<i>Reserved</i>		
1023	<i>Reserved</i>		

REFERENCES CITED IN THE DESCRIPTION

Cited references

This list of references cited by the applicant is for the reader's convenience only. It does not form part of the European patent document. Even though great care has been taken in compiling the references, errors or omissions cannot be excluded and the EPO disclaims all liability in this regard.

Patent documents cited in the description

- [US61567579 \[0001\]](#)
- [US61674503 \[0001\]](#)
- [US61703449 \[0001\]](#)
- [EP20203810 \[0002\]](#)
- [WO2007014681A1 \[0008\]](#)
- [EP1391865A1 \[0009\]](#)

Non-patent literature cited in the description

- **PETER G. J. BARTEN** Contrast Sensitivity of the Human Eye and its Effects on Image Quality, 1999, [\[0033\]](#)
- **SCOTT DALY** Digital Images and Human Vision MIT Press 1993 0000 [\[0033\]](#)

Patentkrav**1. Fremgangsmåde omfattende:**

- 5 - at modtage med en datakoder billeddata med luminansværdier, der repræsenterer absolutte luminansværdier L , der skal kodes;
- at kode med datakoderen det modtagne billeddata til referencekodet billeddata; og
- 10 - at udlæse med datakoderen det referencekodede billeddata, hvor nævnte kodning omfatter afbildning af absolutte luminansværdier til digitale kodeværdier, idet luminansværdierne af det modtagne billeddata repræsenteres af de digitale kodeværdier i det referencekodede billeddata; hvor nævnte afbildning er baseret mindst delvist på en invers af en funktionel model af:

$$Y = \left(\frac{\max \left[\left(V^{1/m} - c_1 \right), 0 \right]}{c_2 - c_3 V^{1/m}} \right)^{1/n},$$

15 hvor:

Y er en normaliseret værdi af en tilsvarende en af de absolutte luminansværdier L , hvor $0 \leq Y \leq 1$, og

$$Y = \frac{L}{10.000}$$

, $0 \leq L \leq 10.000 \text{ cd/m}^2$,

20 V er en normaliseret værdi af en tilsvarende en af de digitale kodeværdier D , der udlæses som referencekodet billeddata, hvor $0 \leq V \leq 1$, og

n , m , c_1 , c_2 og c_3 er forudbestemte værdier, hvor:

$$n = \frac{2610}{4096} \times \frac{1}{4} \approx 0,1593017578125;$$

25 $m = \frac{2523}{4096} \times 128 \approx 78,84375;$

$$c_1 = c_3 - c_2 + 1 = \frac{3424}{4096} \approx 0,8359375;$$

$$c_2 = \frac{2413}{4096} \times 32 \approx 18,8515625; \text{ og}$$

$$c_3 = \frac{2392}{4096} \times 32 \approx 18,6875.$$

30

2. Fremgangsmåden ifølge krav 1, hvor de digitale kodeværdier D er kodeværdier på 10 bits eller 12 bits.
3. Fremgangsmåden ifølge krav 1, hvor de digitale kodeværdier D repræsenterer en samlet værdi af en komponent af billeddataet i et digitalt serielt grænseflade- (SDI) signal.
4. Fremgangsmåden ifølge krav 1, hvor nævnte udlæsning med datakoderen af nævnte referencekodede billeddata omfatter udlæsning af en bitstream
- 10 omfattende nævnte referencekodede billeddata og metadata.
5. Fremgangsmåden ifølge krav 4, hvor nævnte metadata inkluderer en eller flere af: modelparametre, en minimal luminansværdi, en maksimal luminansværdi, en minimal digital kodeværdi og en maksimal digital kodeværdi, et identificeringsfelt,
- 15 der identificerer en kontrastsensitivitetsfunktion blandt en flerhed af CSF'er og en referencevisningsafstand.
6. Fremgangsmåde omfattende:
- at modtage med en dataafkoder kodet billeddata; og
 - 20 - at afkode med dataafkoderen det kodede billeddata, **kendetegnet ved, at** nævnte afkodning omfatter afbildning af digitale kodeværdier i det kodede billeddata til normaliserede luminansværdier baseret mindst delvist på en funktionel model af:

$$Y = \left(\frac{\max[(V^{1/m} - c_1), 0]}{c_2 - c_3 V^{1/m}} \right)^{1/n},$$
- 25 Y er en normaliseret luminansværdi, hvor $0 \leq Y \leq 1$, svarende til absolutte luminansværdier L hvor
- $$Y = \frac{L}{10,000}$$
- , hvor $0 \leq L \leq 10.000 \text{ cd/m}^2$,
- V er en normaliseret værdi af en tilsvarende en af de digitale kodeværdier
- 30 D af det kodede billeddata, hvor $0 \leq V \leq 1$, og
- n , m , c_1 , c_2 og c_3 er forudbestemte værdier, hvor:
- $$n = \frac{2610}{4096} \times \frac{1}{4} \approx 0,1593017578125;$$

3

$$m = \frac{2523}{4096} \times 128 \approx 78,84375 ;$$

$$c_1 = c_3 - c_2 + 1 = \frac{3424}{4096} \approx 0,8359375 ;$$

$$c_2 = \frac{2413}{4096} \times 32 \approx 18,8515625 ; \text{ og}$$

$$c_3 = \frac{2392}{4096} \times 32 \approx 18,6875.$$

5

7. Bitstream omfattende billeddata, **kendetegnet ved, at** billeddataet er kodet med digitale kodeværdier D , der repræsenterer normaliseret luminans Y baseret mindst delvist på en invers af en funktionel model af

$$Y = \left(\frac{\max \left[\left(V^{1/m} - c_1 \right), 0 \right]}{c_2 - c_3 V^{1/m}} \right)^{1/n} ,$$

10

hvor V er en normaliseret værdi af den digitale kodeværdi D ,

hvor $0 \leq Y \leq 1$ og $0 \leq V \leq 1$, og Y svarer til absolutte luminansværdier L ,

hvor

$$Y = \frac{L}{10,000}$$

15

hvor $0 \leq L \leq 10,000 \text{ cd/m}^2$;

hvor n , m , c_1 , c_2 og c_3 er forudbestemte værdier, hvor:

$$n = \frac{2610}{4096} \times \frac{1}{4} \approx 0,1593017578125 ;$$

$$m = \frac{2523}{4096} \times 128 \approx 78,84375 ;$$

$$c_1 = c_3 - c_2 + 1 = \frac{3424}{4096} \approx 0,8359375 ;$$

20

$$c_2 = \frac{2413}{4096} \times 32 \approx 18,8515625 ; \text{ og}$$

$$c_3 = \frac{2392}{4096} \times 32 \approx 18,6875.$$

DRAWINGS

Drawing

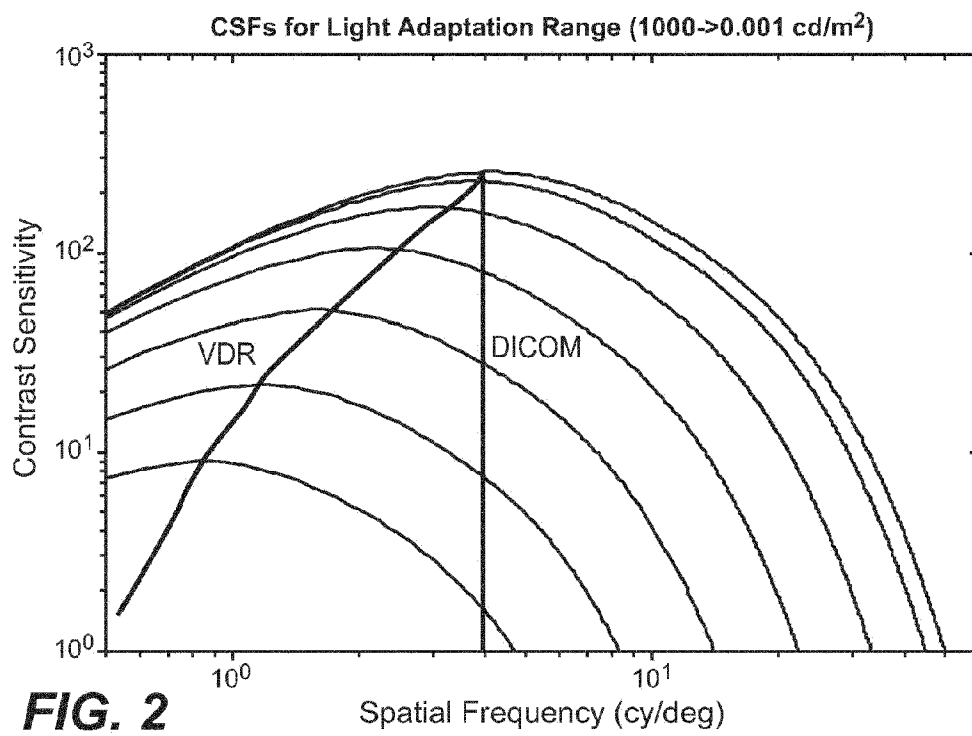
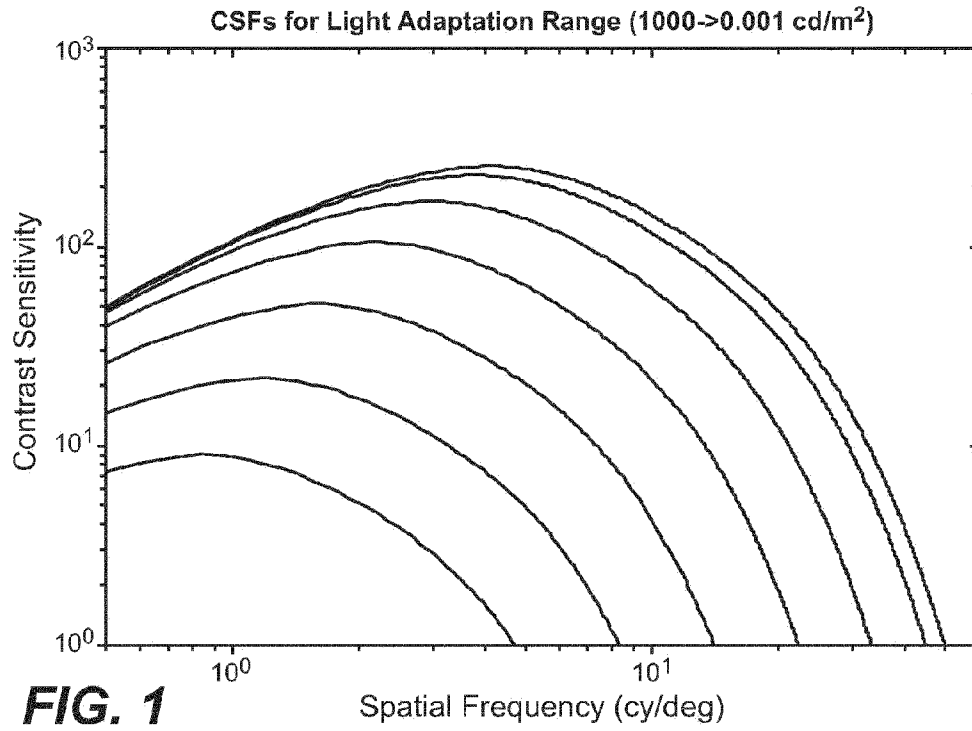

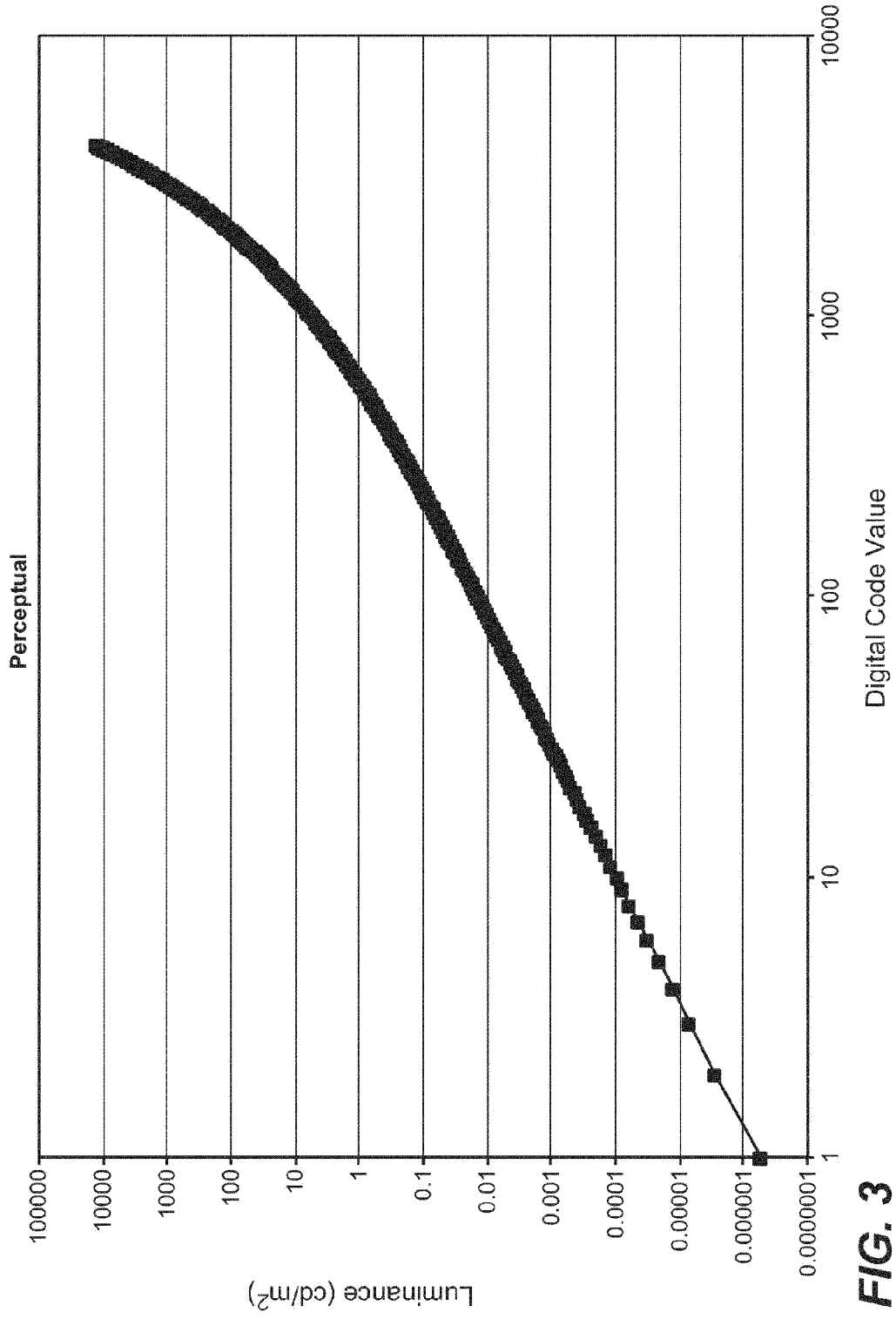

FIG. 3

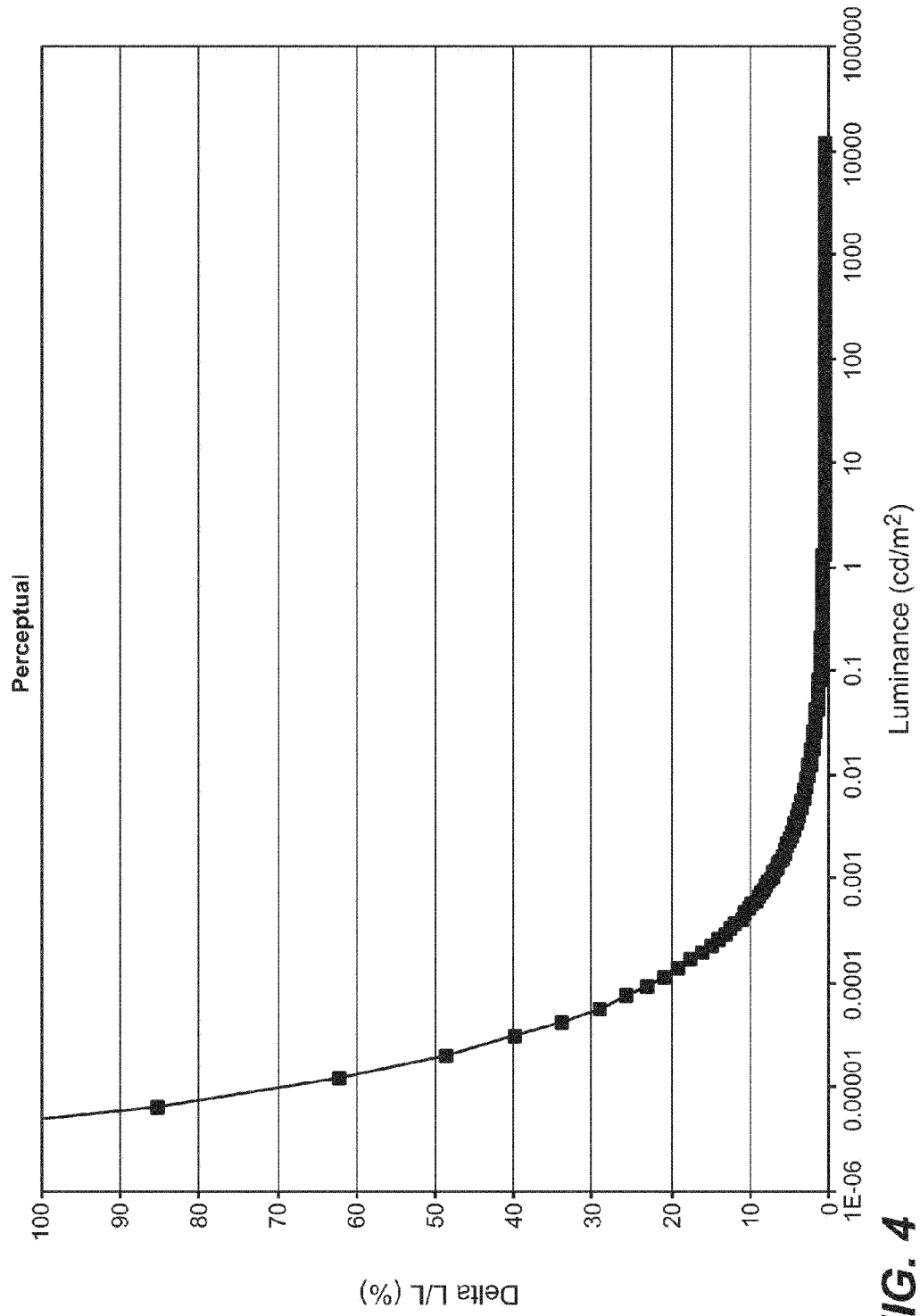

FIG. 4

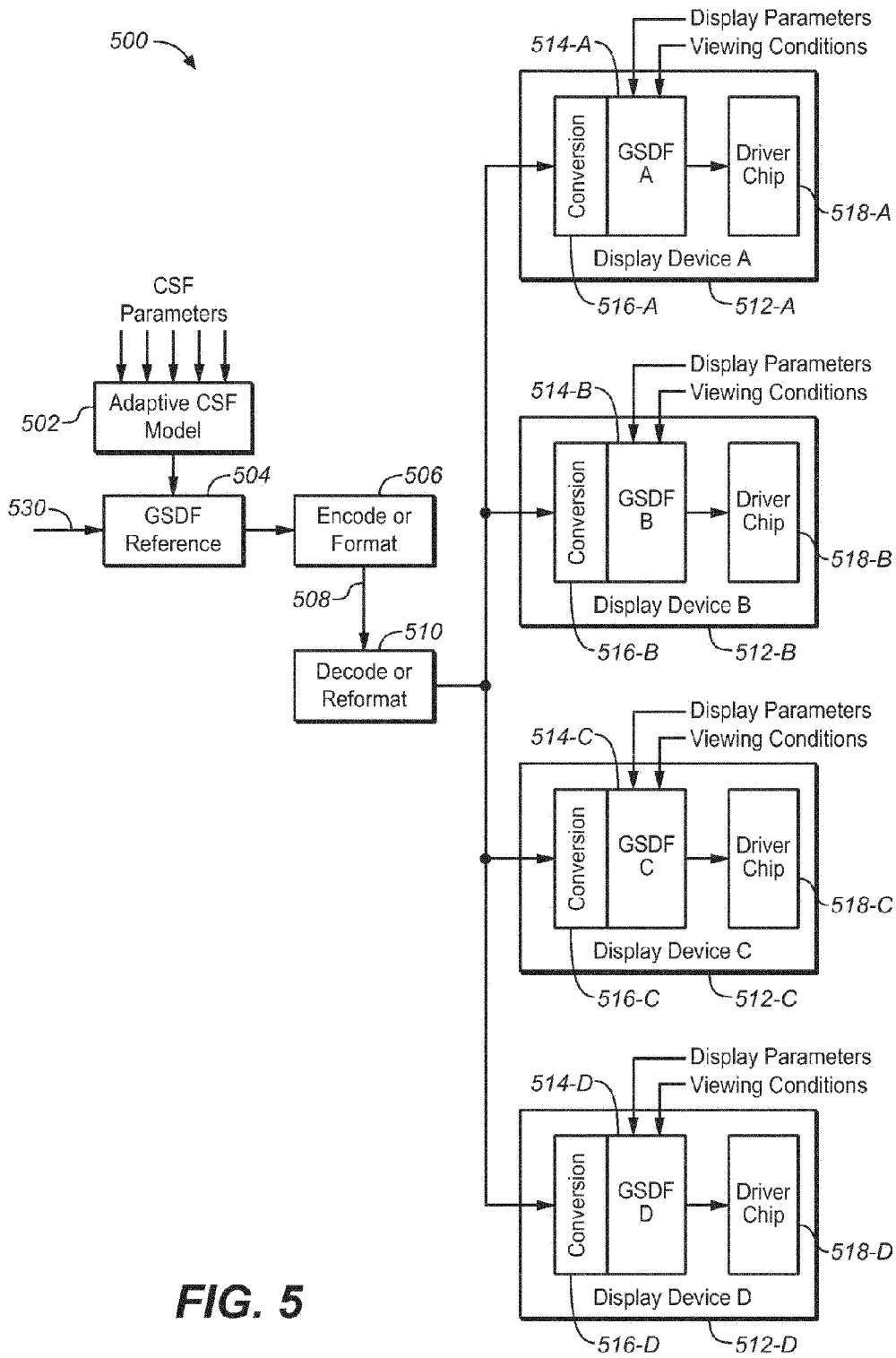

FIG. 5

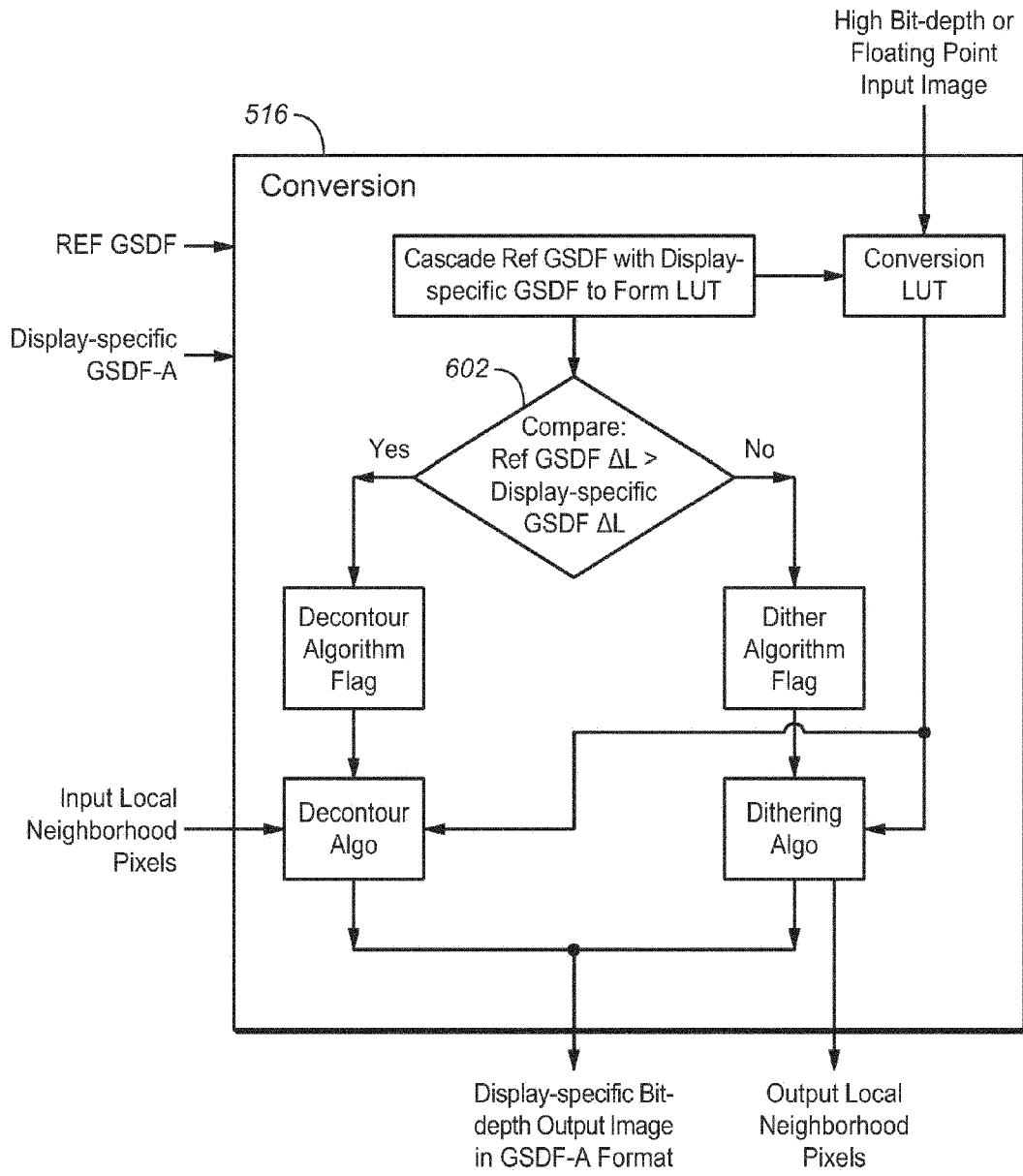

FIG. 6

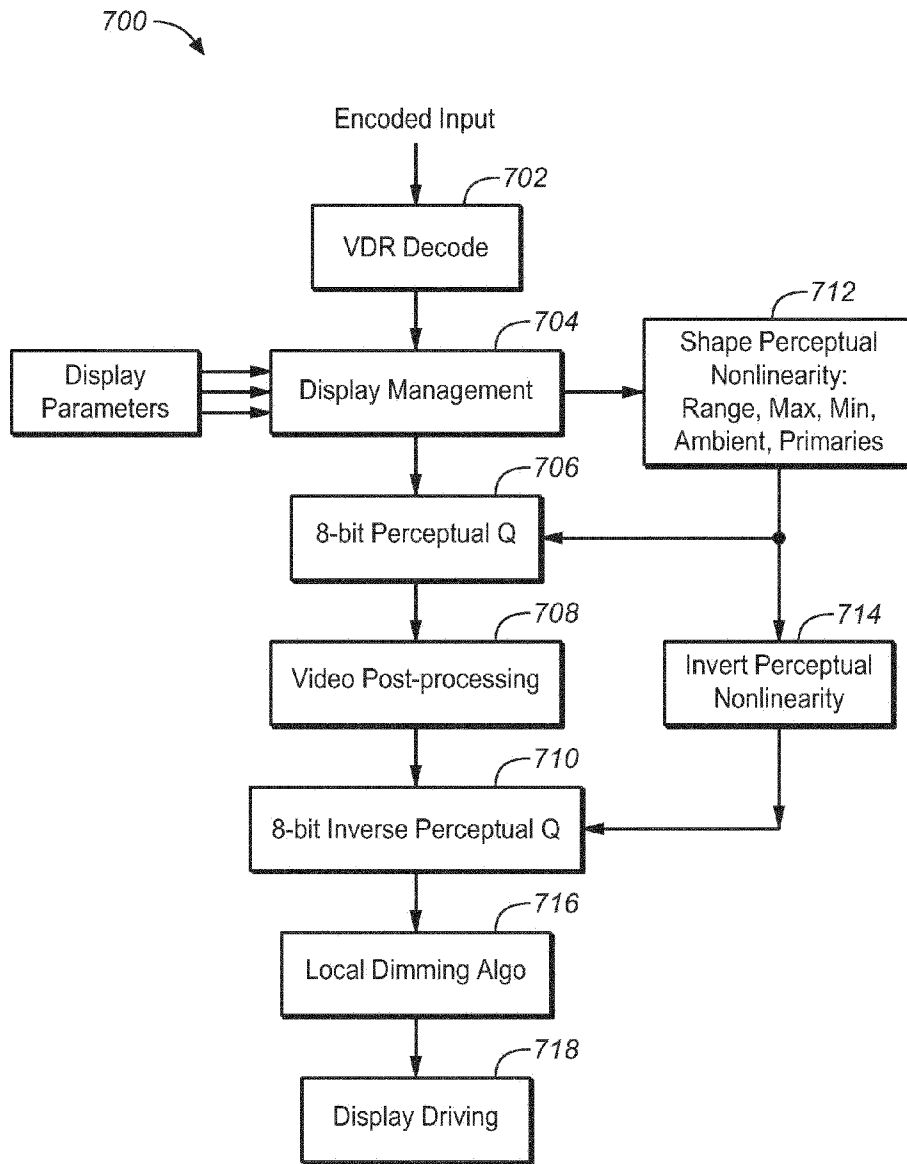
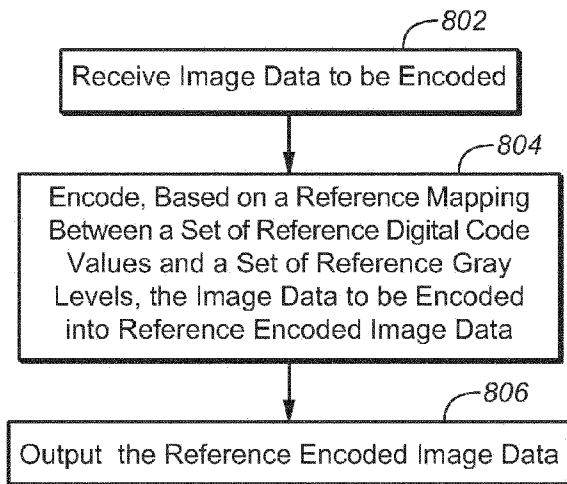
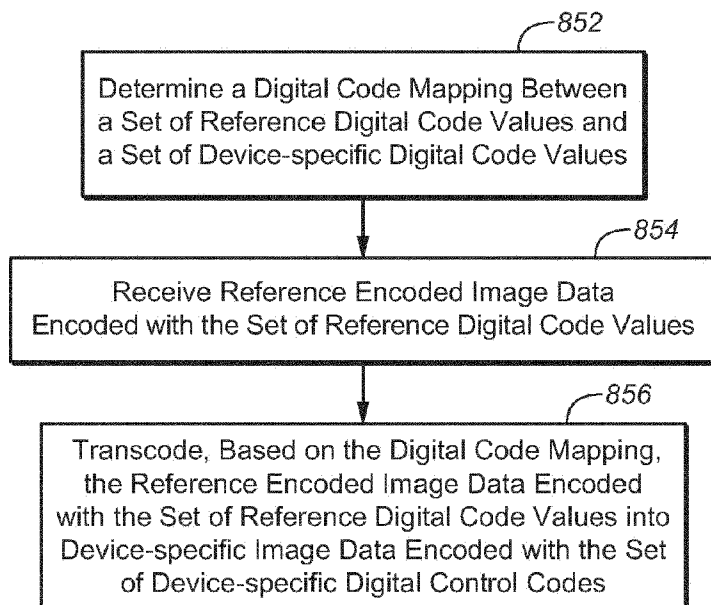

FIG. 7

**FIG. 8A****FIG. 8B**

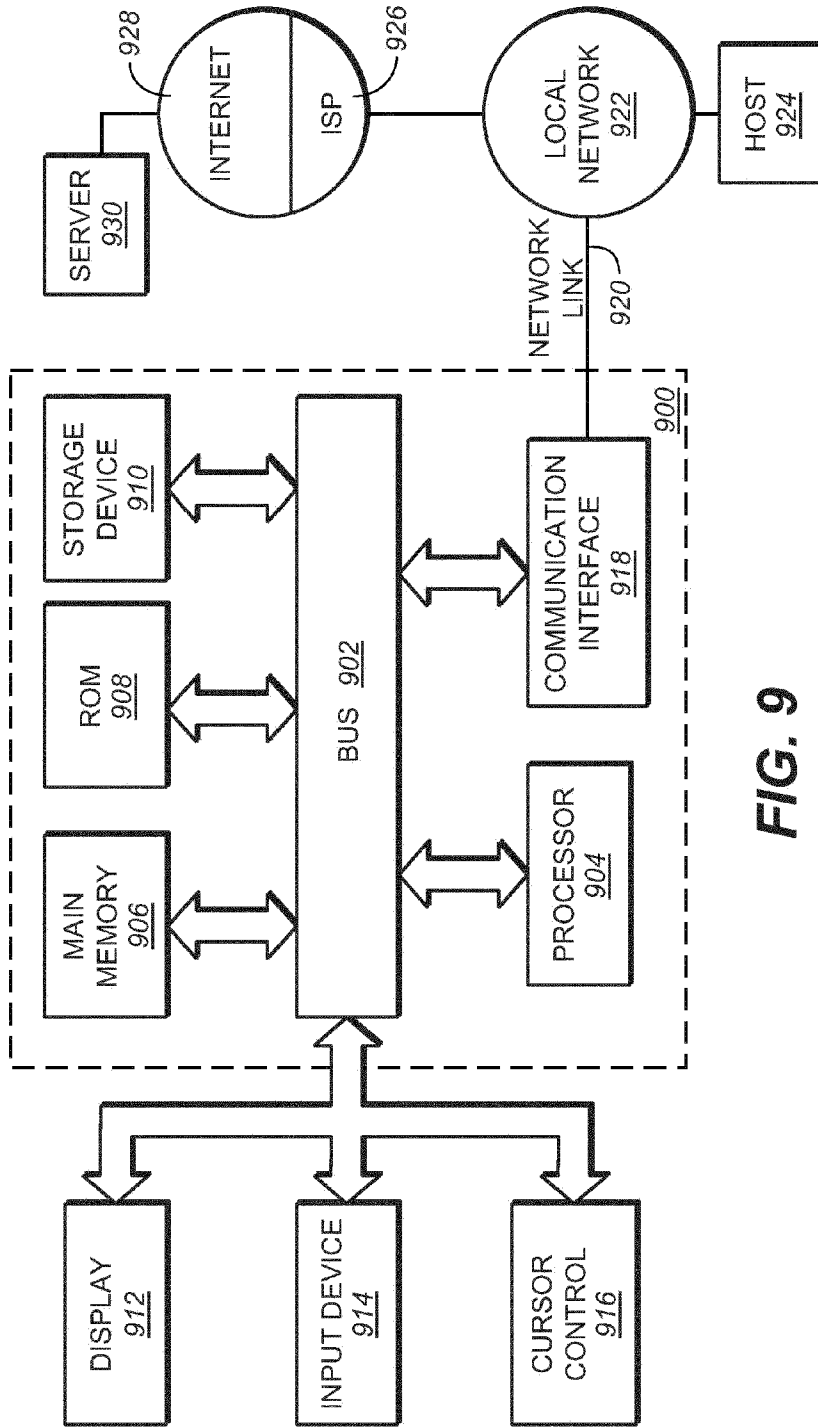

FIG. 9

Quantization	Max Code Error (from CSF peaks)
inf	11.252
4096	11.298
2048	11.373
1024	12.089
512	12.451
256	13.288

FIG. 10A

Parameters		Formula
n	0.16956	$(2778/4096)/4$
		$(2495/4096)*128$
m	77.968	
c1	0.96484	$(3952/4096)$
c2	3.7627	$(3853/4096)*4$
c3	2.5166	$(3436/4096)*4$

FIG. 11

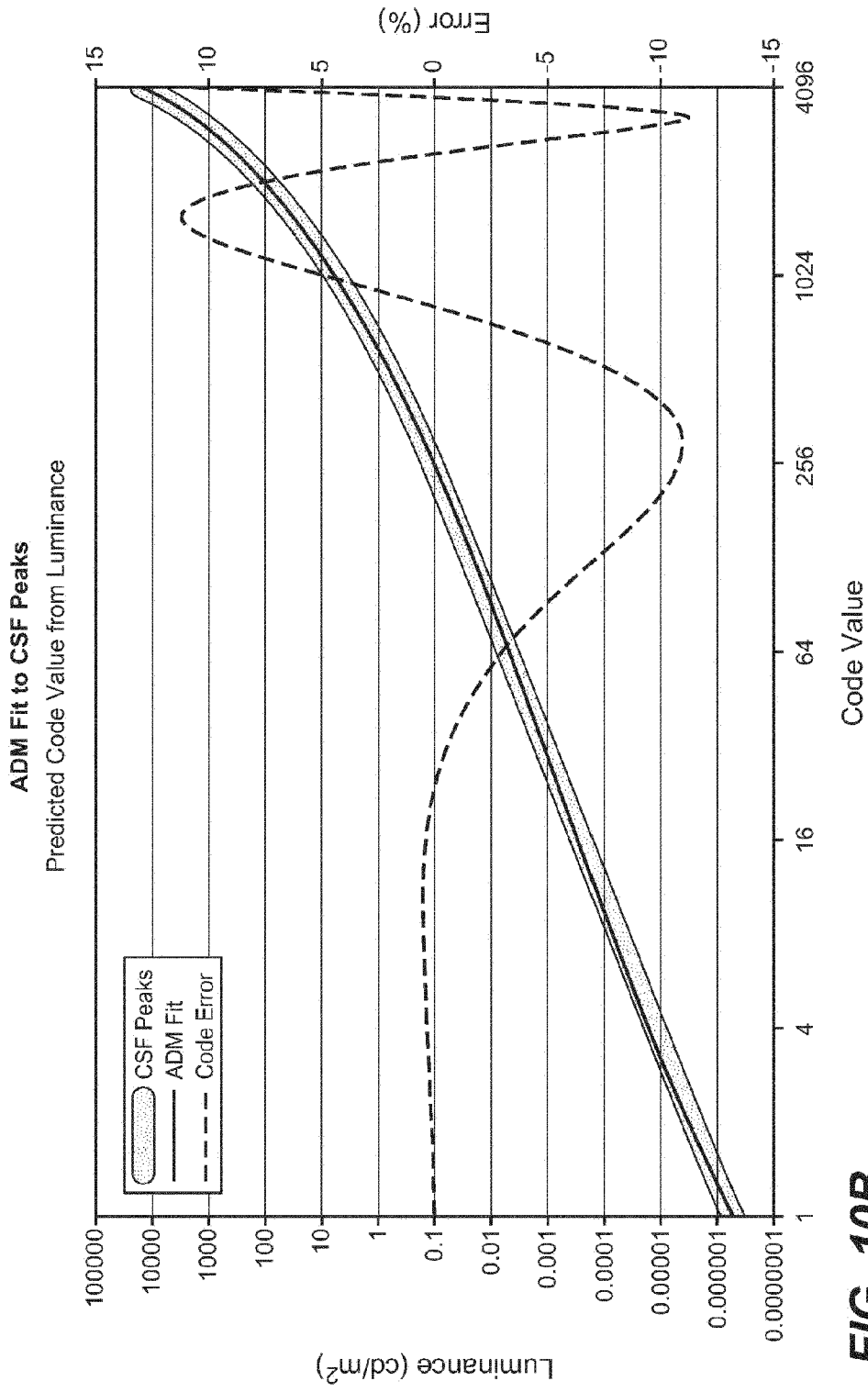

FIG. 10B

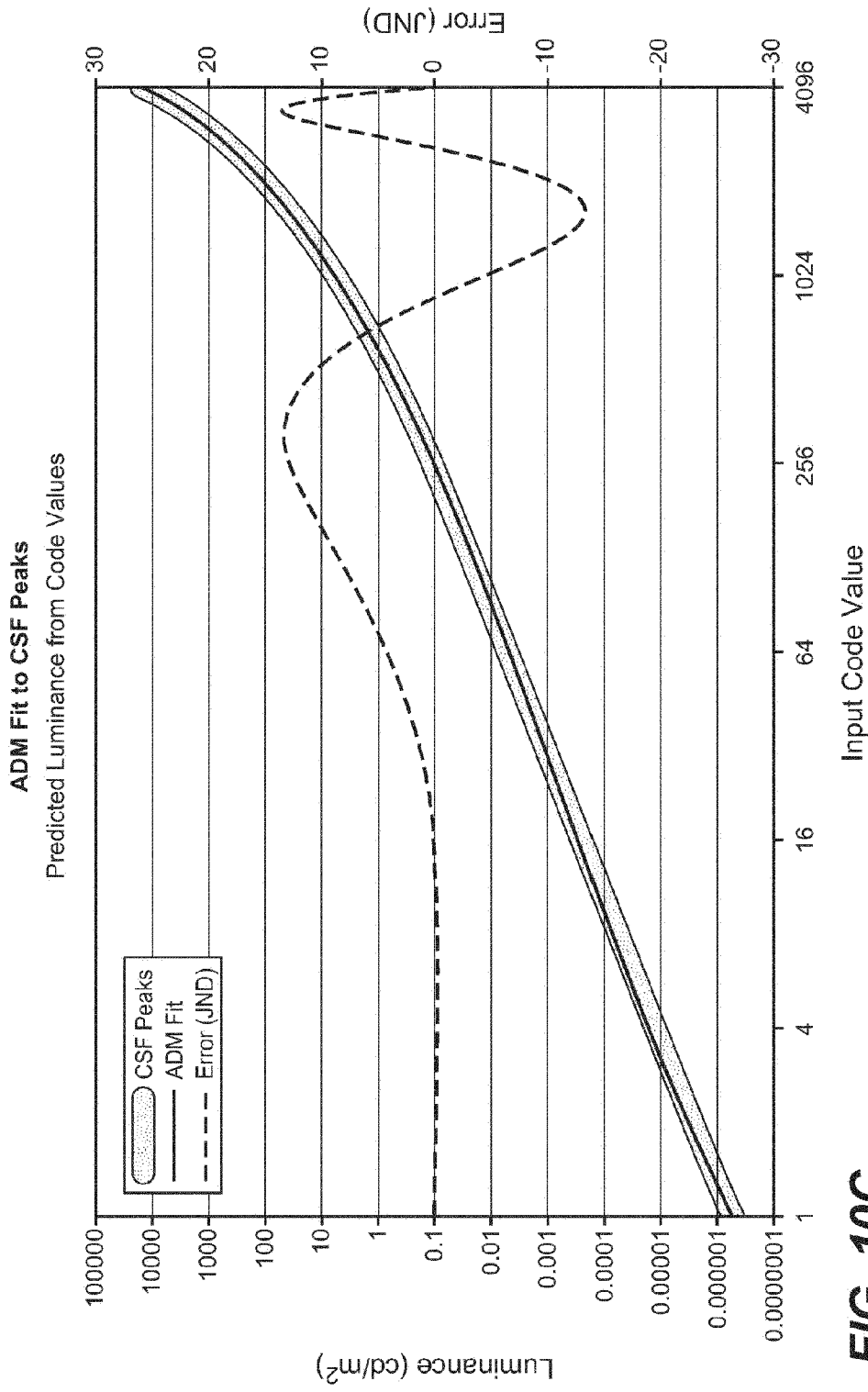

FIG. 10C

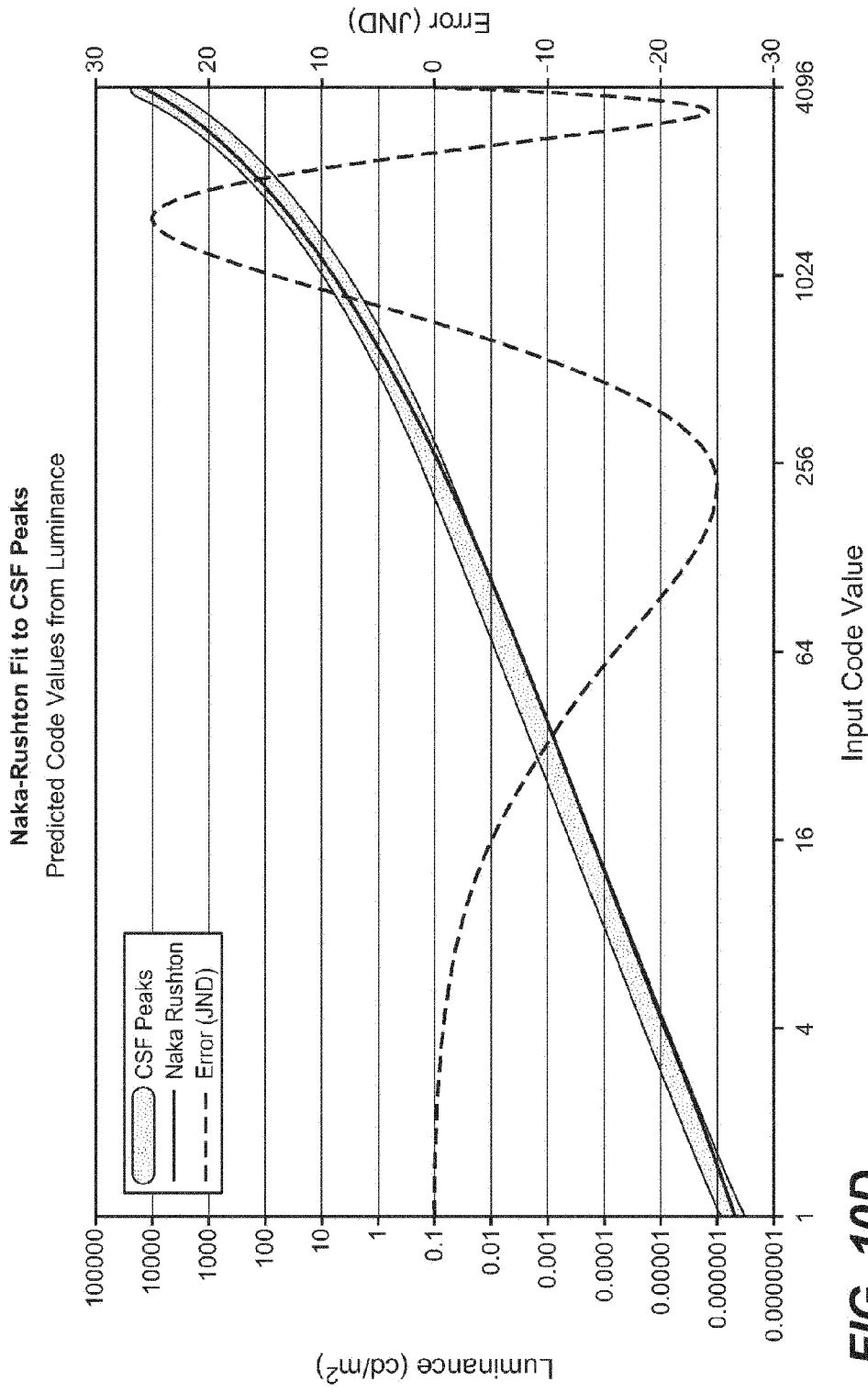

FIG. 10D

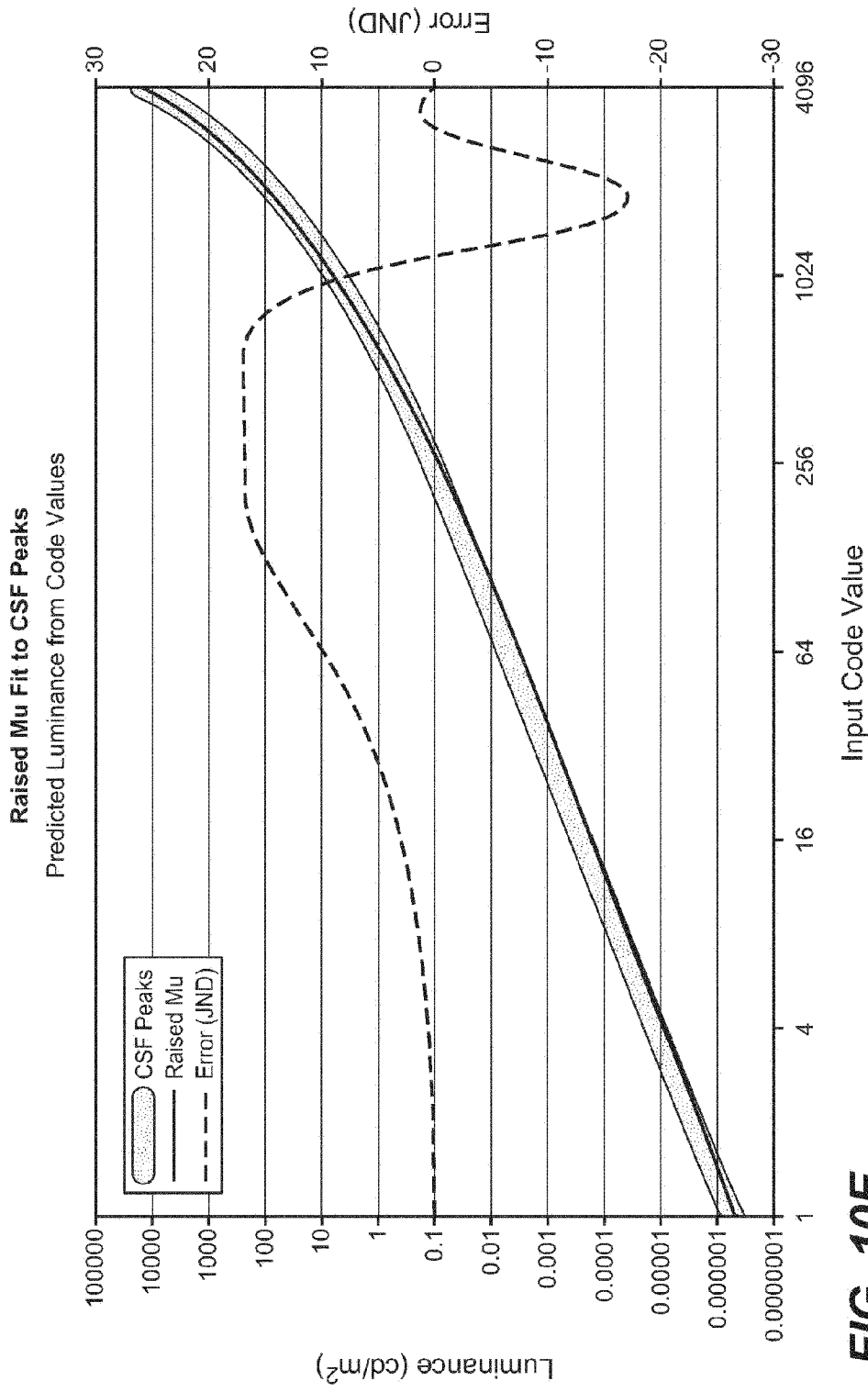

FIG. 10E