

Jan. 13, 1942.

E. LEUPOLD

2,270,131

UNIFORM ADVANCE OF THREAD GUIDE

Filed April 3, 1941

2 Sheets-Sheet 1

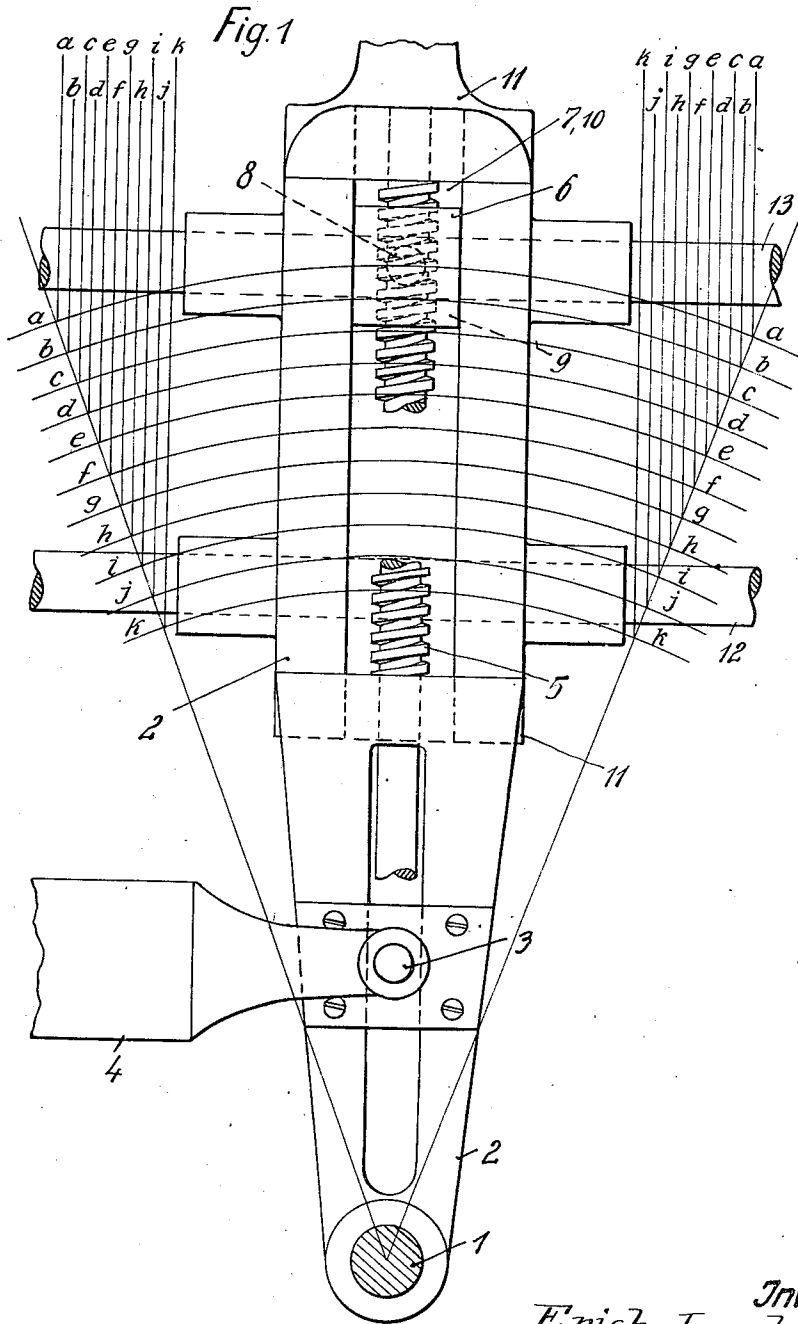

Inventor:
Erich Leupold
By William C. Sinton
Atty.

Jan. 13, 1942.

E. LEUPOLD

2,270,131

UNIFORM ADVANCE OF THREAD GUIDE

Filed April 3, 1941

2 Sheets-Sheet 2

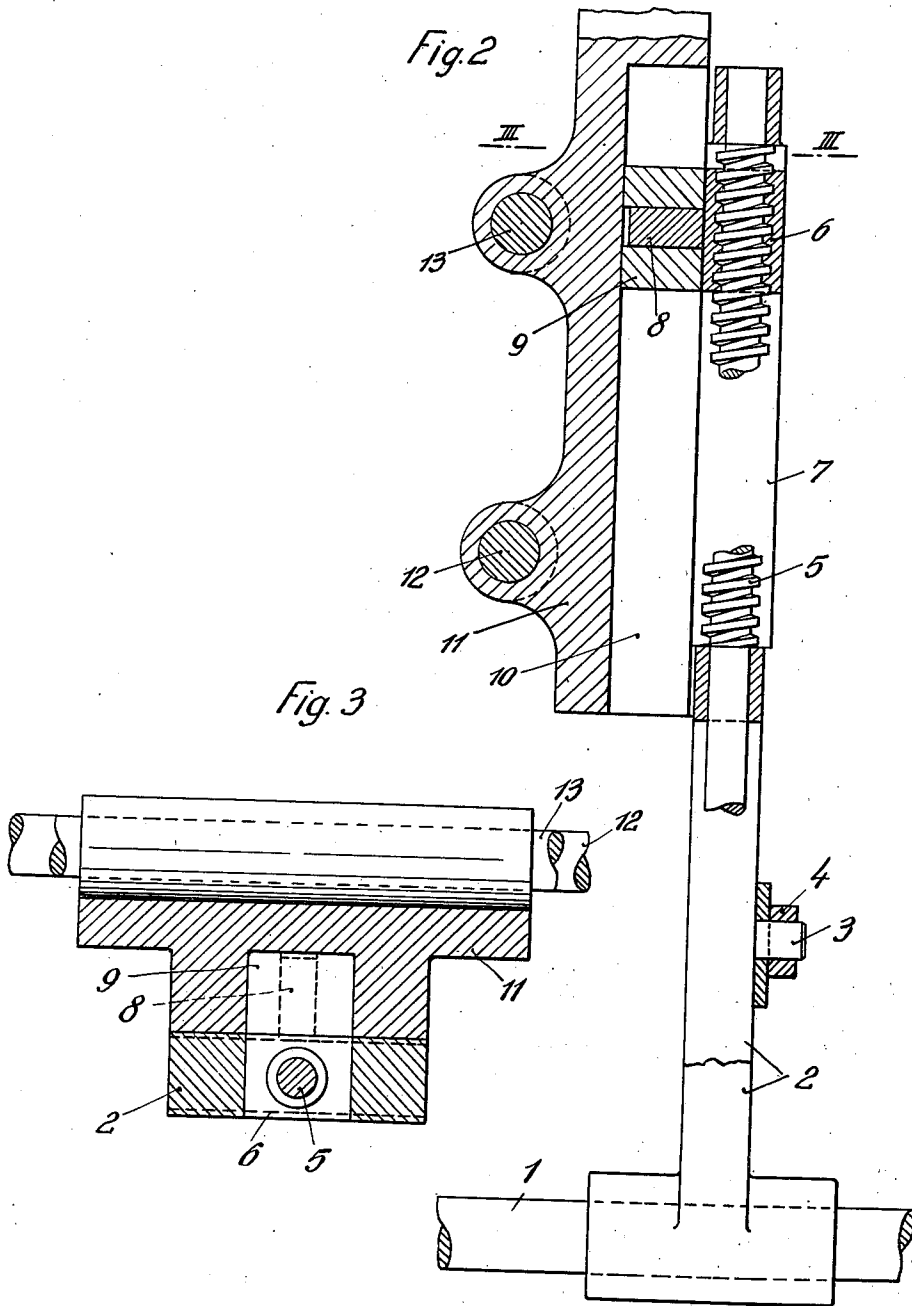

Inventor:
Erich Leupold
By William C. Linton
Atty.

UNITED STATES PATENT OFFICE

2,270,131

UNIFORM ADVANCE OF THREAD GUIDE

Erich Leupold, Lichtensteig, Switzerland

Application April 3, 1941, Serial No. 386,711
In Germany January 24, 1940

4 Claims. (Cl. 66—110)

The present invention relates to a flat full fashioned knitting machine and more particularly is concerned with a knitting machine of this kind provided with a device for obtaining a uniform advance of the thread guide or thread carrier in which the movement to be performed by the slurs moving bar or slurs connecting bar is varied in dependence on the feed movements of the narrowing tackle.

In a known construction of a machine of this kind in which the swinging movements of an arm, operated by the draw cam, are varied by means of a sliding block movably arranged in said arm a curved guide way for this sliding block and a spindle having a thread of an increasing pitch are used which latter, controlled by the narrowing tackle, displaces the sliding block by way of a nut. In this case the drive of the arm is indirectly effected by way of the sliding block guided in the guide way.

The manufacture of curved guide ways as well as of spindles provided with a thread of increasing pitch offer difficulties in so far as special devices and utmost exactness are necessary.

To obviate these drawbacks, the device according to the present invention is so constructed that the slurs moving bar is driven by an arm the swinging angle of which is invariable and the effective length of which is variable. The variation of the length of the arm is controlled by the narrowing tackle.

In the accompanying drawings one construction according to the invention is shown by way of example.

In these drawings:

Fig. 1 is a front elevation of the device according to the invention,

Fig. 2 shows a longitudinal section through this device, and

Fig. 3 is a section on line III—III of Fig. 2.

At 3 a rod 4 movably mounted upon a pin 1 is connected to an arm 2. In a manner known per se the rod 4 transfers the reciprocating movements of the sinker bar produced by a draw cam, not shown in the drawings, upon the arm 2. In the latter a spindle 5 having a thread of uniform pitch is rotatably mounted and upon this thread a nut 6 is arranged in a manner to be displaced in a vertical guide way 7 of the arm 2.

The nut 6 is provided with a pin or bolt 8 engaging the sliding block 9 which may be displaced in a vertical direction in a straight guide way 10 of a slide 11. The latter may horizontally be displaced upon rods 12 and 13 or the like and carries a link to which, in a manner known

per se, the slurs moving bar, not shown in the drawings, is connected.

The slide 11 may also be directly connected to the slurs moving bar. In a manner known per se and, therefore, not shown in the drawings, the threaded spindle 5 is driven by a feed shaft, connected to the narrowing tackle, and by bevel gear wheels.

The operation of the new device is as follows:

If the device limiting the stroke of the thread guide or thread carrier is adjusted by the narrowing tackle, this adjustment is, as has been stated already, transferred by way of a feed shaft and bevel gear wheels to the threaded spindle 5. Hereby the nut 6 arranged upon the thread of the spindle and thereby by way of the bolt 8 carried by the nut 6 the sliding block 9 is moved in the guide way 10 of the slide 11. Consequently for the arm 2 the swinging angle of which is invariable a new effective length results and the stroke of the slide 11 displaceably mounted upon the rods 12 and 13 is varied so that the slurs moving bar linked to the slide 11 also performs a varied movement.

By the arrangement according to the invention uniform feeds of the narrowing tackle always result in uniform stroke variations of the slurs moving bar, as may be seen from the positions *a, b, c, d, e, f, g, h, i, j, k* shown in Fig. 1.

What I claim is:

1. A flat knitting machine provided with a device for obtaining a uniform advance of the thread guide or thread carrier in which the movement to be performed by the slurs moving bar (slurs connecting bar) is varied in dependence on the feed movements of the narrowing tackle, comprising an arm the swinging angle of which is invariable, and a slurs moving bar driven by said arm, the variations in the effective length of said arm being controlled by the narrowing tackle of the knitting machine.

2. A flat knitting machine as set forth, comprising a slurs moving bar, an arm, having an invariable swinging angle, driving said slurs moving bar, a spindle having a thread of uniform pitch mounted in said arm, and a nut arranged upon the thread of said spindle.

3. A flat knitting machine as set forth, comprising a slurs moving bar, an arm, having an invariable swinging angle, driving said slurs moving bar, a spindle having a thread of uniform pitch mounted in said arm, a nut arranged upon the thread of said spindle, a bolt carried by said nut, a slide driving said slurs moving bar and having a straight guide way, a sliding block

adapted to be vertically displaced in said guide way and connected to said nut by said bolt.

4. A flat knitting machine as set forth, comprising a slurs moving bar, an arm, having an invariable swinging angle, driving said slurs moving bar, a spindle having a thread of uniform pitch mounted in said arm, a nut arranged upon

the thread of said spindle, a bolt carried by said nut, rods arranged in horizontal planes, a slide mounted upon said rods and having a straight guide way, a sliding block adapted to be vertically displaced in said guide way and connected to said nut by said bolt.

ERICH LEUPOLD.