



INTERNATIONAL APPLICATION PUBLISHED UNDER THE PATENT COOPERATION TREATY (PCT)

<p>(51) International Patent Classification 5 : H01R 9/07</p>	<p>A1</p>	<p>(11) International Publication Number: WO 95/05015 (43) International Publication Date: 16 February 1995 (16.02.95)</p>
<p>(21) International Application Number: PCT/US94/08878 (22) International Filing Date: 8 August 1994 (08.08.94) (30) Priority Data: 1993/15192 9 August 1993 (09.08.93) KR (71) Applicant (for all designated States except US): BERG TECHNOLOGY, INC. [US/US]; One East First Street, Reno, NV 89501 (US). (72) Inventor; and (75) Inventor/Applicant (for US only): LEE, Hyung, Ku [KR/KR]; 114-105, Karaksiyoung APT., Karak-dong, Songpa-ku, Seoul (KR). (74) Agents: DONOHUE, John, P., Jr. et al.; Woodcock Washburn Kurtz Mackiewicz & Norris, 46th Floor, One Liberty Place, Philadelphia, PA 19103 (US).</p>		<p>(81) Designated States: US, European patent (AT, BE, CH, DE, DK, ES, FR, GB, GR, IE, IT, LU, MC, NL, PT, SE). Published With international search report.</p>

(54) Title: ELECTRICAL CONNECTOR

(57) Abstract

An electrical wire-trap connector mounted on a circuit board of an electrical instrument in order to receive a plurality of cable leads. The electrical connector includes a main body (1) and an operating member (10). The main body includes a plurality of lead receiving holes (4), a larger opening for receiving a terminal (3) having an elastic part (18) as well as an elastic projection (17), a terminal guide groove, a terminal inserting slot (27) for seating a lower shoulder (21) of the terminal thereon, a hole (7) for receiving the elastic projection of the terminal, and a guider (9) and a stop protrusion (12a), both being provided on a side end surface of the main body. The operating member is detachably mounted on the main body and includes an insert guide (14) and a locking guide (15), both guides being provided on a side end of the operating member. The locking guide has a locking shoulder (12) at its lower end. The locking shoulder of the operating member is latched by the stopper of the main body to prevent the operating member from upwardly moving with respect to the main body.

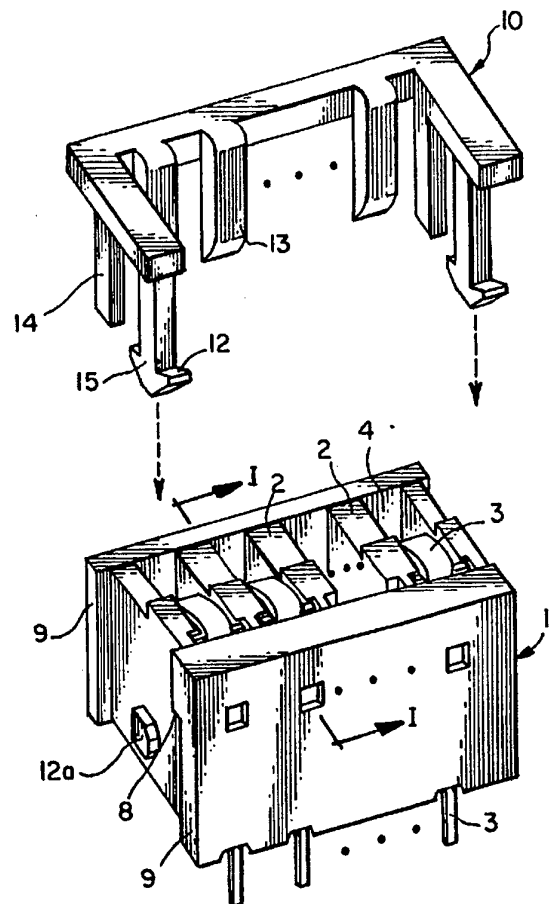

FOR THE PURPOSES OF INFORMATION ONLY

Codes used to identify States party to the PCT on the front pages of pamphlets publishing international applications under the PCT.

AT	Austria	GB	United Kingdom	MR	Mauritania
AU	Australia	GE	Georgia	MW	Malawi
BB	Barbados	GN	Guinea	NE	Niger
BE	Belgium	GR	Greece	NL	Netherlands
BF	Burkina Faso	HU	Hungary	NO	Norway
BG	Bulgaria	IE	Ireland	NZ	New Zealand
BJ	Benin	IT	Italy	PL	Poland
BR	Brazil	JP	Japan	PT	Portugal
BY	Belarus	KE	Kenya	RO	Romania
CA	Canada	KG	Kyrgystan	RU	Russian Federation
CF	Central African Republic	KP	Democratic People's Republic of Korea	SD	Sudan
CG	Congo	KR	Republic of Korea	SE	Sweden
CH	Switzerland	KZ	Kazakhstan	SI	Slovenia
CI	Côte d'Ivoire	LI	Liechtenstein	SK	Slovakia
CM	Cameroon	LU	Luxembourg	SN	Senegal
CN	China	LV	Latvia	TD	Chad
CS	Czechoslovakia	LK	Sri Lanka	TG	Togo
CZ	Czech Republic	LU	Luxembourg	TJ	Tajikistan
DE	Germany	MC	Monaco	TT	Trinidad and Tobago
DK	Denmark	MD	Republic of Moldova	UA	Ukraine
ES	Spain	MG	Madagascar	US	United States of America
FI	Finland	ML	Mali	UZ	Uzbekistan
FR	France	MN	Mongolia	VN	Viet Nam
GA	Gabon				

ELECTRICAL CONNECTOR

BACKGROUND OF THE INVENTION

Field of the Invention

The present invention relates in general to an
5 electrical connector, and more particularly to a wire-trap
electrical connector and for directly receiving and latching a
plurality of cable leads without soldering.

Description of the Prior Art

Fig. 1 shows a prior art connector including a main
10 body 51 and an operating member 62 which is detachably coupled
to the main body 51. The main body 51 is provided at its upper
section with a plurality of cable lead receiving holes 61 which
receive individual cable leads and are separated from each
other by a plurality of vertical partitions 52. In order to
15 detachably mount the operating member 62 on the main body 51,
the main body 51 has an elastic stopper 55 as well as a guider
57 on each side end thereof. The operating member 62 has a
gripe 69 and an insert 64 on each side end thereof. Each of
the insert 64 is inserted into a corresponding receiving hole

- 2 -

60 of the main body 51. At this time, the operating member 62 is reliably prevented from an accidental separation from the main body 51 by a stop protrusion 67 and an auxiliary protrusion 68. A pair of protrusions 67 and 68 is provided on
5 the outer surface of each insert 64 of the operating member 62. In addition, a plurality of terminals 53 is upwardly inserted into the corresponding lead receiving holes 61 of the main body 51.

Fig. 2 is a cross sectional view along the section
10 line I - I of Fig. 1 of the prior art connector, which is provided with the cable leads 72. A lead 72 of cable 71 inserted into the connector is reliably positioned by an elastic part 59 of a corresponding terminal 53 as well as by a corresponding projections 66 of the operating member 62. In
15 order to place the cable leads 72 at a predetermined position, the cable leads 72 are inserted into the connector before the projections 66 and the terminal 53 are inserted into the main body 51. After the cable lead insertion, the projections 66 of the operating member 62 are inserted in order to fixedly
20 support the cable leads 72 at their predetermined position with respect to the main body 51. Finally, the terminals 53 having individual elastic parts 59 are inserted from the bottom into a terminal inserting hole 54 of the main body 51 so as to fixate the cable leads 72 at their predetermined position in
25 cooperation with the projections 66 of the operation member 62. At this time, each of the inserted terminals 53 is prevented from accidental separation from the main body 51 since an elastic projection 58 of the terminal 53 is elastically

- 3 -

engaging a corresponding recess 61a formed on an inner surface of a side wall of the main body 51.

Fig. 3 shows a side view of the prior art connector in which the inserts 64 of the operating member 62 are received by the main body 51. When the inserts 64 of the operating member 62 are fully received in the receiving hole 60 of the main body 51, the upper end of the auxiliary protrusion 68 is latched by the elastic stopper 55 of the operating member 62 so that the operating member 62 is reliably prevented from the upward movement to separate separation from the main body 51.

However, the prior art connector has a undesirably large gap between the terminals 53 and the side wall of the main body 51 such that the terminals 53 are apt to be bent. Another problem of the prior art connector is that the lower section of the main body 51 where the terminals are inserted, is wildly open so that the terminals may be accidentally separated from the connector. Furthermore, the contact area of each terminal with a corresponding cable lead is relatively small so that a desired contact of the terminal with the cable lead may not be achieved when the connector is used in an environment where vibration frequently occurs.

SUMMARY OF THE INVENTION

It is, therefore, an object of the present invention to provide an electrical connector which overcomes the aforementioned problems. A main body has a closed bottom except for a plurality of terminal inserting slots, and the main body is provided with a terminal inserting hole at the top

- 4 -

for allowing a plurality of terminals having individual elastic parts to be downwardly inserted into the main body.

In order to accomplish the above object, an electrical connector in accordance with a preferred embodiment of the present invention includes a main body having a plurality of lead receiving holes provided at an upper section of the main body in order to receive individual cable leads; a large opening provided on the upper section of the main body in order to receive a terminal; the terminal having an elastic part as well as an elastic projection; a terminal guide groove provided on a side wall of the main body in order to guide insertion of the terminal; a terminal inserting slot provided on a bottom of the main body in order to seat a lower shoulder of the terminal thereon for preventing a downward separation of the terminal from the main body; a hole provided on the side wall of the main body in order to receive the elastic projection of the terminal for preventing an upward separation of the terminal from the main body; and a guider and a stop protrusion, both being provided on each side end surface of the main body, the guider having a stopper at its upper section; and an operating member detachably coupled to the main body and including: an insert guide and a locking guide, both guides being provided on each side end of the operating member, and the locking guide having a locking shoulder at its lower end.

25 BRIEF DESCRIPTION OF THE DRAWINGS

The above and other objects, features and other advantages of the present invention will be more clearly

- 5 -

understood from the following detailed description taken in conjunction with the accompanying drawings, in which:

Fig. 1 is an exploded perspective view of a prior art electrical connector.

5 Fig. 2 is a cross sectional view along the section line I - I of Fig. 1 of the prior art connector showing that a main body is coupled to an operating member.

Fig. 3 is a side view of the prior art connector showing that an insert of the operating member is inserted in
10 the main body.

Fig. 4 is an exploded perspective view of an electrical connector in accordance with the present invention.

Fig. 5 is a cross sectional view of the connector taken along the section line II - II of Fig. 4, Showing a main
15 body coupled to an operating member.

Fig. 6 is a plan view of a connector terminal of Fig. 5.

Fig. 7 is a side view of the connector of the present invention, showing that the operating member is coupled to the
20 main body.

Fig, 8 is a bottom view of the connector of the present invention.

DESCRIPTION OF THE PREFERRED EMBODIMENT

Fig. 4 shows one embodiment of an electrical connector
25 in accordance with the present invention. The connector includes a main body 1 and an operating member to which is detachably coupled to the main body 1. The main body is

- 6 -

provided at its upper section with a plurality of lead receiving holes 4 which receive individual cable leads and are separated from each other by a plurality of vertical partitions 2. In order to detachably mount the operating member 10, 5 having a plurality of projections 13, on the main body 1, a stopper 8 is formed on the upper section of a guider 9 which is provided at each side end of the main body 1. The main body 1 also includes stop protrusions 12a which is formed on each side end surface of the main body 1. The operating member 10 has an 10 insert guide 14 and a locking guide 15 on each side end thereof. The locking guide 15 of the operating member 10 is provided at its distal end with a locking shoulder 12 for engaging the stopper 8 of the guider 9 of the main body 1 so as to prevent the operating member 10 from accidentally or 15 undesirably separating from the main body 1. The main body 1 also has a large opening at its upper section where a plurality of terminals 3 having individual elastic parts is downwardly inserted into the main body 1 along individual terminal guide grooves 6 of the main body 1. In order to prevent the inserted 20 terminals 3 from undesirably separating from the main body 1, the main body 1 has at its side wall with the same number of holes 7 as that of the terminals 3. Each of the holes 7 of the main body 1 receives an elastic projection 17 of a corresponding terminal 3 which will be described with reference 25 to Figure 5.

Fig. 5 is a cross sectional view along the section line II - II of the connector of Fig. 4. A lead 26 of a cable 24 is inserted into the connector and accurately positioned on

- 7 -

its place by an elastic part 18 of a corresponding terminal 3 as well as by a corresponding projection 13 of the operating member 10. In order to position the cable leads 26 at these positions, the cable leads 26 are inserted into the connector 5 before the projections 13 of the operating member 10 are not inserted in the main body 1. After each of the cable leads is inserted into the connector, the corresponding projections 13 of the operating member 10 are inserted in order to fixedly support the cable leads 26 at a desirable position by urging 10 the cable leads against the corresponding terminal 3. Each terminal 3 having the elastic part 18 is also inserted into the main body 1 through a terminal inserting hole provided on the upper section of the main body 1. The main body 1 has a terminal inserting slot 27 where a lower shoulder of a 15 corresponding terminal 3 is seated so as to prevent a downward movement of the terminal 3 with respect to an undesirable separation from the main body 1. The elastic projection 17 of the terminal 3 is latched in a corresponding elastic projection receiving hole 7 of the main body 1 so that the terminal 3 is 20 prevented from undesirably moving in an upward direction or separating from the main body 1. The bottom surface of the main body 1 except for the terminal inserting slots 27 is closed. The main body 1 is provided at its bottom section with a bending part 16, which is adapted for supporting the terminal 25 3 at a predetermined angle. The main body is also at its top section with a recess 20 for allowing the elastic part 18 of the terminal 3 to be smoothly pushed backwards towards the recess 20 when the cable lead 26 is inserted into the connector.

- 8 -

Fig. 6 shows a plan view of the terminal 3 including the lower shoulder 21, the elastic projection 17 and the elastic part 18.

As shown in Fig. 7, when the operating member 10 is inserted in the main body 1, the locking shoulder 12 of the locking guide 15 of the operating member 10 is latched by the stop protrusion 12a of the main body 1. Even when the operating member 10 is accidentally moved upwardly from the main body 1, the locking shoulder 12 of the locking guide 15 is caught by the stopper 8 formed on the upper section of the guider 9 of the main body 1, so as to prevent the accidental separation of the operating member 10 from the main body 1.

Fig. 8 shows the bottom surface of the main body 1, which is closed except for the terminal inserting slots 27 and a depressed portion of the bending part 16 which is adapted for supporting the terminal 3 angled at a predetermined angle.

As described above, according to the present invention, a plurality of terminals inserted in the main body of the connector is in close contact with an inner surface of a side wall of the main body so as to substantially prevent the terminals from being bent as well as from accidentally separating from the main body. In addition, according to the current invention the contact area of each terminal with a corresponding cable lead is substantially larger than the prior art connector so that a desired contact between a terminal and a corresponding cable lead is maintained even when the connector is substantially vibrated.

Another advantage of the present invention is that

- 9 -

each terminal is inserted into the main body along a terminal guide groove of the main body to substantially avoid misalignment during insertion.

Although the preferred embodiments of the present
5 invention have been disclosed for illustrative purposes, those skilled in the art will appreciate that various modifications, additions and substitutions are possible, without departing from the scope and spirit of the invention as disclosed in the accompanying claims.

- 10 -

WHAT IS CLAIMED IS:

1. An electrical connector comprising:
 - a main body including:
 - a plurality of lead receiving holes provided on
5 a top surface section of said main body for receiving individual cable leads;
 - a larger opening provided on the upper section of said main body in order to downwardly receive a terminal, said terminal having an elastic part as well as an elastic
10 projection;
 - a terminal guide groove provided on a side wall of said main body in order to guide insertion of said terminal;
 - a terminal inserting slot provided on a bottom of said main body in order to seat a lower shoulder of said
15 terminal thereon, thus to prevent a downward separation of said terminal from said main body;
 - a hole provided on said side wall of said main body in order to receive said elastic projection of said terminal, thus to prevent an upward separation of said terminal
20 from said main body; and
 - a guider and a stop protrusion, both being provided on each side end surface of said main body, said guider having a stopper at its upper section; and
 - an operating member detachably coupled to said
25 main body and including:
 - an insert guide and a locking guide, both guides being provided on each side end of said operating member, and

- 11 -

said locking guide having a locking shoulder at its lower end.

2. The electrical connector according to claim 1, wherein said locking shoulder of said operating member is caught by said stopper of said main body when said operating member upwardly moves with respect to said main body, thus to prevent an unconscious upward separation of said operating member from said main body, while said locking shoulder of said operating member is caught by said stop protrusion of said main body when said operating member is downwardly inserted into said main body.

3. The electrical connector according to claim 1, wherein said bottom of said main body except said terminal inserting slot is closed.

4. The electrical connector according to claim 1, wherein said main body is provided at said side wall with a recess for receiving a rear section of said elastic part of said terminal which is pushed backwards when a corresponding cable lead is inserted into said main body.

5. The electrical connector according to claim 1, wherein said main body is provided at its lower section with a bending part for bending said terminal to an outward direction of said main body.

- 12 -

6. An wire trap connector for holding a cable lead, comprising:

a connector housing providing slots inside said connector housing, each of said slots having a terminal guide
5 groove and a contact wall;

a contact terminal placed in each of said slots along said terminal guide, a substantial portion of said contact terminal engaging said contact wall, said contact terminal having a resilient end for making an electrical
10 contact between the cable lead placed therein; and

an operating member removably placed against the cable lead and said resilient end to ascertain the electrical contact between the cable lead and said contact terminal.

7. The wire trap connector according to claim 6
15 wherein, said contact terminal has a hook, said contact wall having a through hole for accepting said hook.

8. The wire trap connector according to claim 6 wherein, said connector housing has a bottom wall and a bore thereon, said contact terminal exiting said connector housing
20 through said bore.

9. The wire trap connector according to claim 8 wherein, said operating member has a latch mechanism located at one end of said operating member, said latch mechanism extending to an outside surface of said connector housing when
25 said operating member being placed inside said connector

- 13 -

housing, said latch having a projection extending towards said bottom wall and further comprising a pair of locking shoulders located each side of said projection, said connector housing having a pair of stop protrusions located on said outside surface, each of said locking shoulders engaging corresponding one of said stop protrusion.

10. The wire trap connector according to claim 6 wherein, said contact wall further comprises a recess to provide a space for said resilient end of said contact terminal to move.

11. The wire trap connector according to claim 8 wherein, said bottom wall has a depressed portion adjacent to said bore for said contact terminal to be bent along said depressed portion.

Fig. 1

PRIOR ART

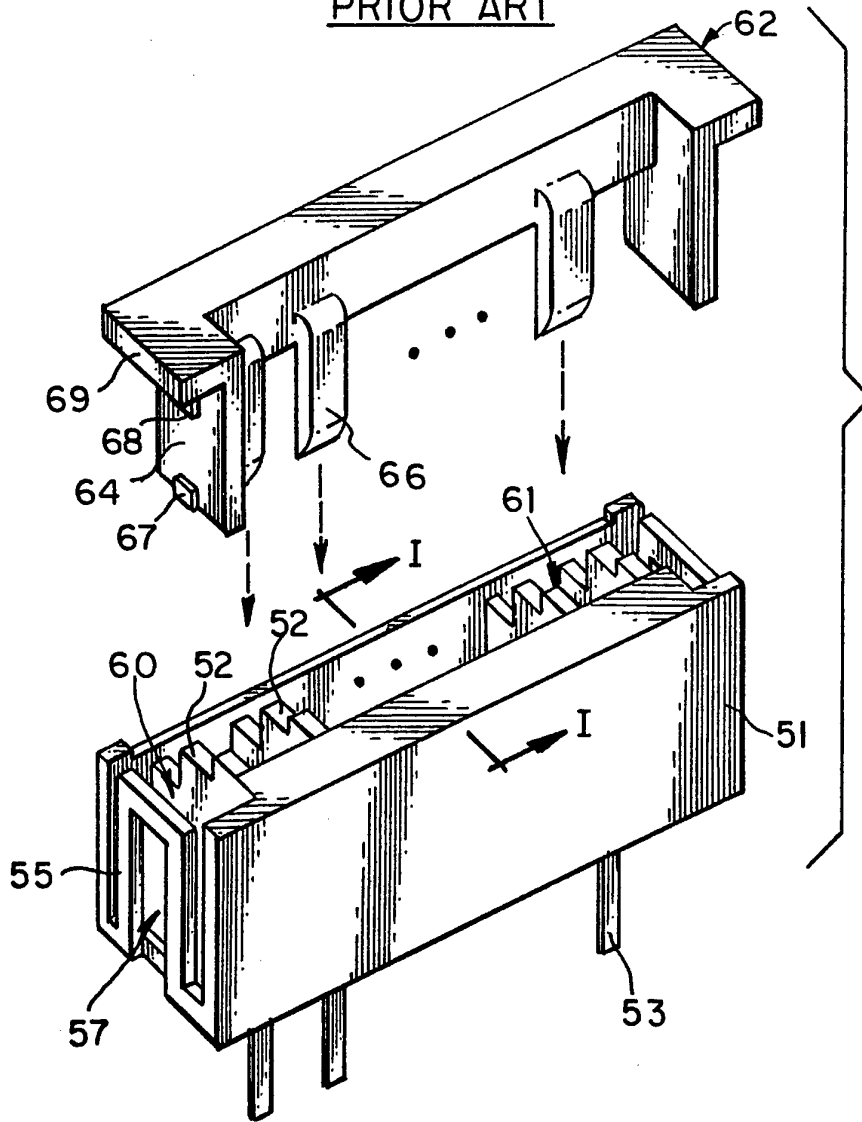

Fig. 2

PRIOR ART

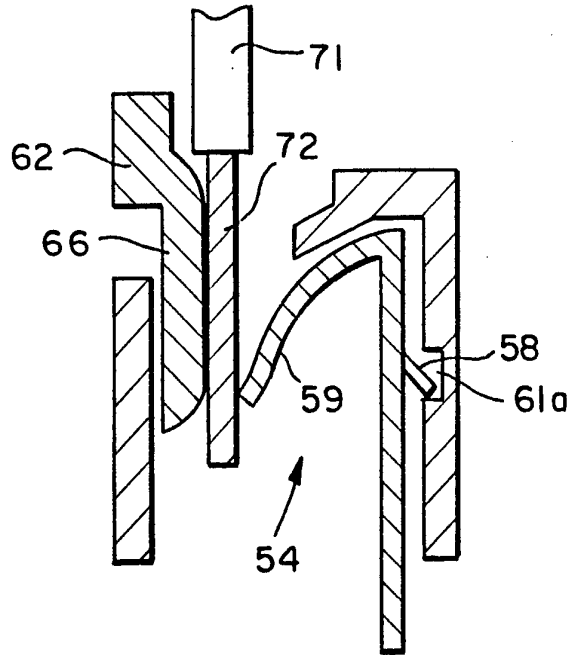

Fig. 3

PRIOR ART

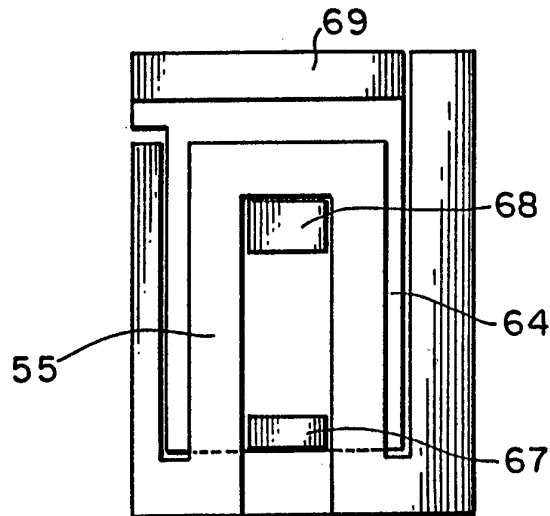

Fig. 4

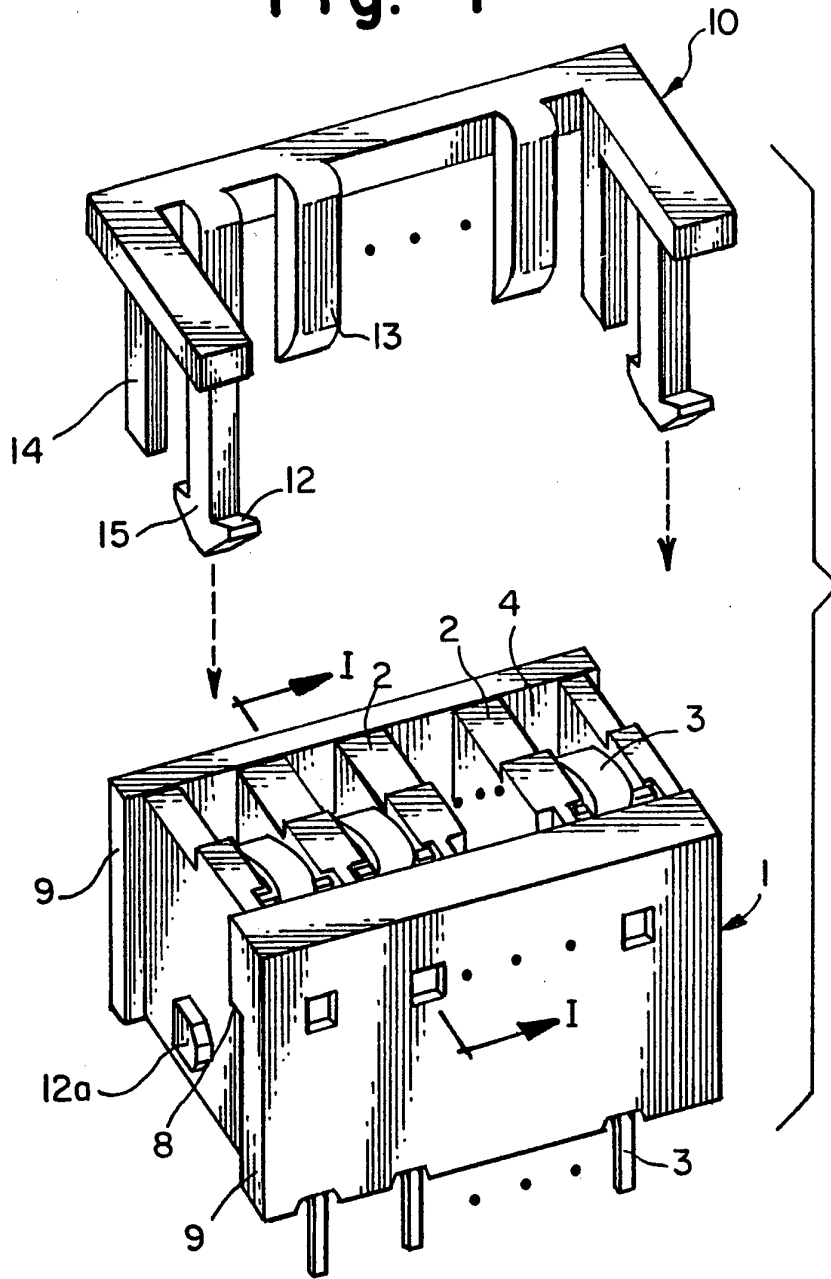

Fig. 5

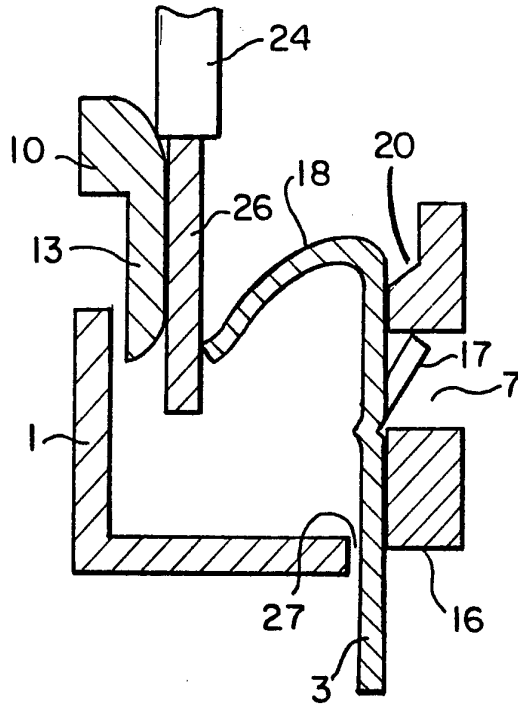

Fig. 6

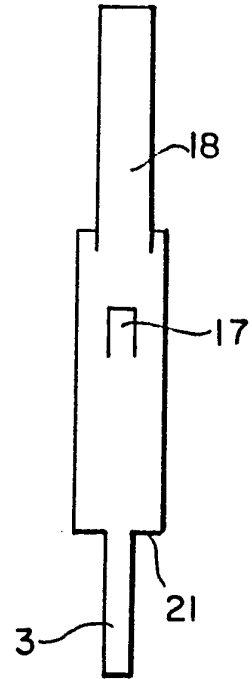

Fig. 7

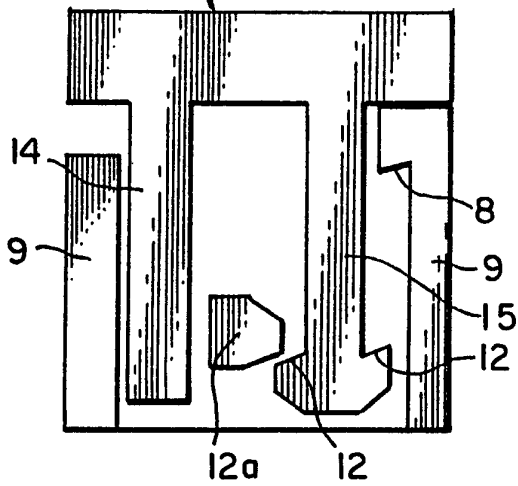
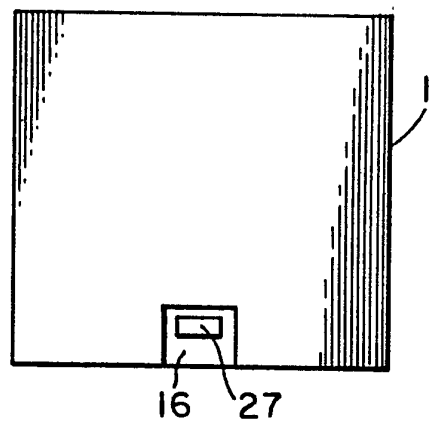

Fig. 8



INTERNATIONAL SEARCH REPORT

International application No.
PCT/US94/08878

A. CLASSIFICATION OF SUBJECT MATTER IPC(5) :HO1R 9/07 US CL :439/260 According to International Patent Classification (IPC) or to both national classification and IPC		
B. FIELDS SEARCHED Minimum documentation searched (classification system followed by classification symbols) U.S. : 439/260, 67, 77, 492, 493, 495 Documentation searched other than minimum documentation to the extent that such documents are included in the fields searched NONE Electronic data base consulted during the international search (name of data base and, where practicable, search terms used) NONE		
C. DOCUMENTS CONSIDERED TO BE RELEVANT		
Category*	Citation of document, with indication, where appropriate, of the relevant passages	Relevant to claim No.
X ---- Y Y	US, A, 4,580,867 (WRIGHT ET AL.) 08 April 1986 See entire document US, A, 3,596,235 (TEURLINGS ET AL.) 27 July 1971 See entire document	1-10 ----- 11 11
<input type="checkbox"/> Further documents are listed in the continuation of Box C. <input type="checkbox"/> See patent family annex.		
* Special categories of cited documents: "A" document defining the general state of the art which is not considered to be part of particular relevance "E" earlier document published on or after the international filing date "L" document which may throw doubts on priority claim(s) or which is cited to establish the publication date of another citation or other special reason (as specified) "O" document referring to an oral disclosure, use, exhibition or other means "P" document published prior to the international filing date but later than the priority date claimed "T" later document published after the international filing date or priority date and not in conflict with the application but cited to understand the principle or theory underlying the invention "X" document of particular relevance; the claimed invention cannot be considered novel or cannot be considered to involve an inventive step when the document is taken alone "Y" document of particular relevance; the claimed invention cannot be considered to involve an inventive step when the document is combined with one or more other such documents, such combination being obvious to a person skilled in the art "&" document member of the same patent family		
Date of the actual completion of the international search 02 NOVEMBER 1994		Date of mailing of the international search report 21 NOV 1994
Name and mailing address of the ISA/US Commissioner of Patents and Trademarks Box PCT Washington, D.C. 20231 Facsimile No. (703) 305-3230		Authorized officer GARY PAUMEN <i>Joni Hell</i> Telephone No. (703) 308-1414