

1 566 207

- (21) Application No. 21656/77 (22) Filed 23 May 1977 (19)
- (31) Convention Application No. 688 745 (32) Filed 21 May 1976 in
- (33) United States of America (US)
- (44) Complete Specification published 30 April 1980
- (51) INT. CL.³ A61F 7/00
- (52) Index at acceptance
A5R EH
- (72) Inventors PAUL D. BAUER and ROLAND E. FLICK



(54) FLEXIBLE HEATING OR COOLING PAD

(71) We, GAYMAR INDUSTRIES INC., a Corporation organised and existing under the laws of the State of New York, United States of America, of One Bank Street, Orchard Park, New York 14127, United States of America, do hereby declare the invention, for which we pray that a patent may be granted to us, and the method by which it is to be performed, to be particularly described in and by the following statement:—

This invention relates to a flexible heating or cooling pad for use in personal heating and cooling apparatus of the type wherein a temperature controlling fluid is circulated through a thin, flexible heat exchange structure. Such thermal devices have been known and used for many years in a variety of applications. Generally, these devices have comprised hoses or similar articles arranged in various patterns throughout a pad or matrix of some design which may or may not have been covered with a cloth material. Some devices have employed single passageways in various configurations and other devices have employed multiple passageways in order to provide a large heat transferring area within a given sized pad or blanket. All of these prior art devices have suffered from a particular problem which has generally been called "pinch off". The problem of pinch off manifests itself when a thermal pad or blanket has one of the fluid passages kinked or otherwise obstructed so that the flow of fluid therethrough is prevented. When this occurs the function of the device is immediately destroyed. It has been proposed in the past to use a hard, pinch off resistant material for the fluid passage; however, when such a material is used it becomes difficult to bend the pad or it becomes uncomfortable for a patient or user who is employing the pad.

It would, therefore, be an advance in the art if a thermal device of this nature could be provided which obviated or greatly reduced the problems associated with pinch off. Prior art pads or thermal devices have

also been troubled by a wide temperature variances across the pad, caused primarily by the elongated, serpentine configurations of the fluid passages. These long passages, with their continuous welds, also made the pads less flexible than desired and made them difficult to wrap about a limb.

Prior art devices of this type have also had the problem of not being capable of being folded. Folding immediately caused a pinch-off condition. Therefore, it would be a further advance in the art if a pad were provided which could be folded many different ways and still maintain fluid flow.

In accordance with the present invention there is provided a flexible heating or cooling pad formed from two overlying sheets of impervious material peripherally sealed to form a fluid-tight compartment, a fluid inlet and a fluid outlet communicating with the said compartment and a plurality of fluid-directing passages formed within the compartment, the said passages being defined by a multiplicity of discrete sealed areas extending between the two sheets.

In one embodiment of the invention each passage is connected to all other passages. Thus, any pressure between two or more adjacent sealed areas sufficiently great to prevent fluid flow therebetween merely directs the fluid to other passages. It is this feature which allows the pad or device to be folded into smaller sizes, e.g., halves or quarters, and still be utilized.

The invention will now be described in more detail with the aid of examples illustrated in the accompanying drawings, in which:—

Fig. 1 is a plan view of one embodiment of the invention;

Fig. 2 is a perspective view of the pad of Fig. 1 folded in half;

Fig. 3 is a perspective view of the pad of Fig. 1 folded in quarters;

Fig. 4 is a side elevation of a hose termination for the pad;

Figs. 5—7 are similar views of alternative forms of hose termination; and

50
55
60
65
70
75
80
85
90
95

Fig. 8 is a plan view of the hose termination of Fig. 4.

Referring now to the drawings with greater particularity there is shown in Fig. 1 a thermal device 10 for providing area heating or cooling to a mammalian body or limb thereof. Device 10 comprises a flexible pad formed from two overlying sheets 12 and 14 of fluid impervious material such as polyvinyl chloride (PVC) sheet. The sheets 12 and 14 are provided with a peripheral seal 16 to form a fluid tight compartment 18. Fluid inlet 20 and fluid outlet 22 in the form of hoses 20a and 22a, respectively, are provided in one section of the device 10 and communicate at one end thereof with compartment 18. The other ends thereof are connected, respectively, to a fluid source and a fluid drain, not shown.

A plurality of fluid carrying passages 24 are provided within compartment 18, these passages being defined by a large plurality of oriented, discontinuous sealed areas 26 having a given space, designated as A, therebetween. In the instant embodiment of Fig. 1, the sealed areas 26 are circular in configuration, this shape providing strength as well as even fluid flow thereabout; however, it is to be understood that other geometric shapes can be employed, such as squares, rectangles, bars and ovals. When the material is PVC, the sealed areas and peripheral seal can be formed by dielectric welding.

In the preferred embodiment, at least one of the fluid directing passages is formed to provide a fluid inlet passage 24a and at least one other of the fluid directing passages is formed to provide a fluid outlet passage 24b. The passages 24a and 24b are defined between the peripheral seal and discontinuous lines of sealed areas 26a and 26b, which areas have a spacing B therebetween which is less than A. As an aid to ventilation, some or all of the seal areas 26, 26a and 26b can be provided with apertures 27 therethrough.

The serpentine arrows overlying the passages 24, 24a, and 24b in Fig. 1 indicate the normal direction of fluid flow therethrough. It can clearly be seen from viewing this Fig. 1 that a pinch-off between any two or more areas 26 will have virtually no effect upon the fluid flow, since such a restricted area will simply be bypassed.

A further advantage of this construction is illustrated in Figs. 2 and 3 which show, respectively, a device 10 folded in half and a device 10 folded in quarters. In each of these conditions the available section of the device 10 which communicates with the inlet and outlet means 20 and 22, continues to function normally.

The pattern of the sealed areas 26 which form the main body of device 10 is capable

of many variations: e.g., the pattern in Fig. 1 is a linear, square design having sealed areas at the corners of a square with alternate rows being offset by 1/2 square. Hexagonal patterns are also appropriate as are non-linear patterns. The particular pattern employed will determine the direction of fluid flow.

The peripheral seal 16 also performs a function in aiding fluid flow, and is preferably provided with rounded corners.

A further area where pinch-off has always been a problem is that area immediately adjacent the point where the fluid inlet and outlet means join the interior of the compartment 18. This condition is effectively reduced or eliminated by insuring that hoses 20a and 22a terminate within compartment 18 in a discontinuous plane. This can be accomplished as shown in Fig. 1 by extending one of the hoses further into compartment 18 than the other. Alternatively, the discontinuous plane can be provided at the terminal end of the hose.

In Fig. 4 the terminal end of inlet hose 20a is provided with a single V notch 28.

In Fig. 5 the end is provided with multiple, elongated V notches 30; in Fig. 6 perforations 32 are provided; and in Fig. 7 a single diagonal cut 34. Fig. 8 is a plan view of the hose of Fig. 4.

When formed with either of these terminations a discontinuous plane exists within compartment 18, thereby making it extremely difficult for a pinch-off to occur in this area.

It will be seen from the above description that the pad can be folded and still function; it is virtually impossible to pinch off; it is simple and economical to fabricate; and it can be covered and used to dispense medicaments or be moistened for wet heat applications. The lack of continuous welded serpentine passages makes the device more flexible when fluid filled and allows ready conformance with uneven body areas.

Further, tests with water of about 105°F have shown less than about 3°F to 4°F temperature variation between various parts of the device.

WHAT WE CLAIM IS:—

1. A flexible heating or cooling pad formed from two overlying sheets of impervious material peripherally sealed to form a fluid-tight compartment, a fluid inlet and a fluid outlet communicating with the said compartment and a plurality of fluid-directing passages formed within the compartment, the said passages being defined by a multiplicity of discrete sealed areas extending between the two sheets.

2. A pad as claimed in claim 1 in which the fluid inlet and the fluid outlet are adjacent to one another.

3. A pad as claimed in claim 1 or 2, having a fluid inlet region and a fluid outlet region within said compartment and communicating respectively with the fluid inlet and the fluid outlet, the said inlet and outlet regions being defined between the peripheral seal and respective lines of said discrete sealed areas with a closer spacing than the sealed areas in the rest of the compartment.
4. A pad as claimed in claim 3 in which the discrete sealed areas outside the inlet and outlet regions are arranged in a linear pattern.
5. A pad as claimed in any of the preceding claims in which the discrete sealed areas are substantially circular.
6. A flexible pad as claimed in any of the preceding claims in which the fluid inlet and the fluid outlet terminate within the compartment in a discontinuous plane.
7. A pad as claimed in claim 6 in which the inlet and outlet are formed by hoses.
8. A pad as claimed in claim 7 wherein said discontinuous plane for the terminal part of said hoses is achieved by extending one hose further into said compartment than the other hose.
9. A pad as claimed in claim 7 wherein said discontinuous plane for the terminal part of said hoses is achieved by notches formed therein.
10. A pad as claimed in claim 7 wherein said discontinuous plane for the terminal part of said hoses is achieved by a diagonal termination.
11. A pad as claimed in claim 7 wherein said discontinuous plane for the terminal part of said hoses is achieved by perforating said terminal part.
12. A pad as claimed in any of the preceding claims in which the impervious material is a dielectrically weldable polyvinyl chloride.
13. A pad as claimed in claim 12 in which the peripheral seal and the discrete sealed areas are dielectrically welded.
14. A flexible heating or cooling pad substantially as described with reference to Figs. 1 to 3 of the accompanying drawings, with or without the modification of any of Figs. 4 to 8.

REDDIE & GROSE,
Agents for the Applicants,
16 Theobalds Road,
London WC1X 8PL.

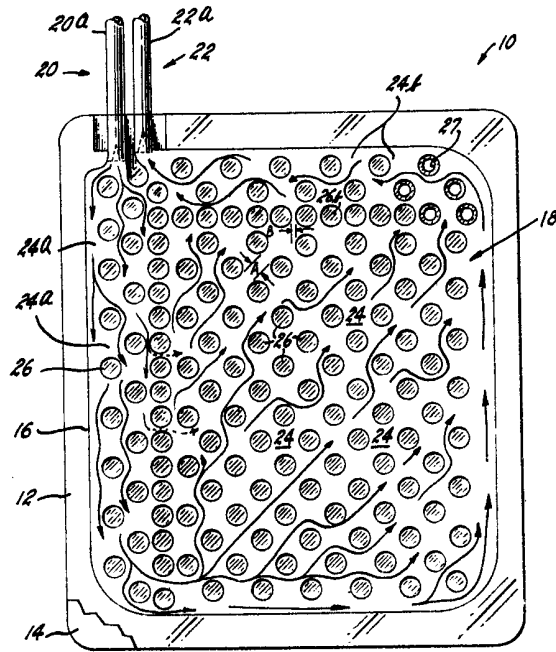

Fig. 1

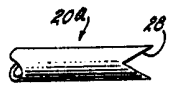

Fig. 4

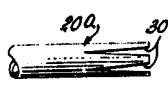

Fig. 5

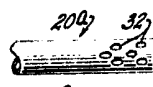

Fig. 6

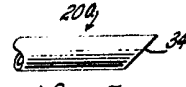

Fig. 7

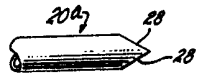

Fig. 8

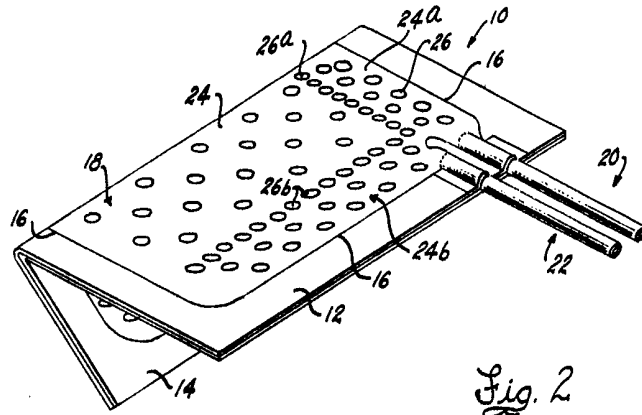

Fig. 2

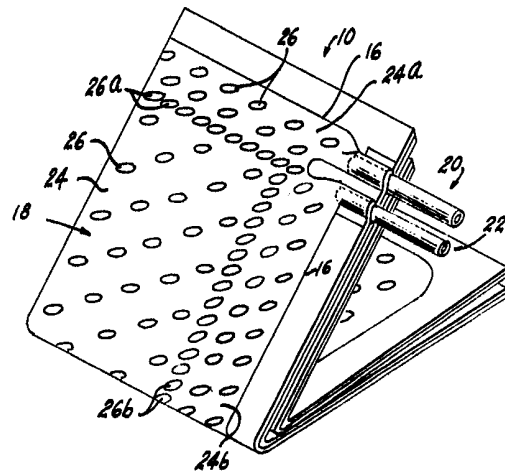

Fig. 3