



(86) Date de dépôt PCT/PCT Filing Date: 2004/07/30
 (87) Date publication PCT/PCT Publication Date: 2005/02/10
 (45) Date de délivrance/Issue Date: 2011/05/17
 (85) Entrée phase nationale/National Entry: 2006/01/30
 (86) N° demande PCT/PCT Application No.: US 2004/024581
 (87) N° publication PCT/PCT Publication No.: 2005/012091
 (30) Priorités/Priorities: 2003/07/30 (US60/491,179);
 2004/03/11 (US60/551,771)

(51) Cl.Int./Int.Cl. *B67C 3/22* (2006.01),
B65B 21/00 (2006.01), *B65B 3/04* (2006.01),
B65B 53/00 (2006.01), *B65B 63/08* (2006.01),
B65D 1/02 (2006.01), *B65D 79/00* (2006.01),
B67C 3/24 (2006.01), *B67C 7/00* (2006.01)

(72) Inventeurs/Inventors:
 KELLEY, PAUL, US;
 GOSS, KENT, US;
 SHEETS, PHILIP, US;
 LYON, TED, US;
 RYL-KUCHAR, CHARLES A., US

(73) Propriétaire/Owner:
 GRAHAM PACKAGING COMPANY L.P., US

(74) Agent: MCCARTHY TETRAULT LLP

(54) Titre : SYSTEME DE MANIPULATION DE RECIPIENT
 (54) Title: CONTAINER HANDLING SYSTEM

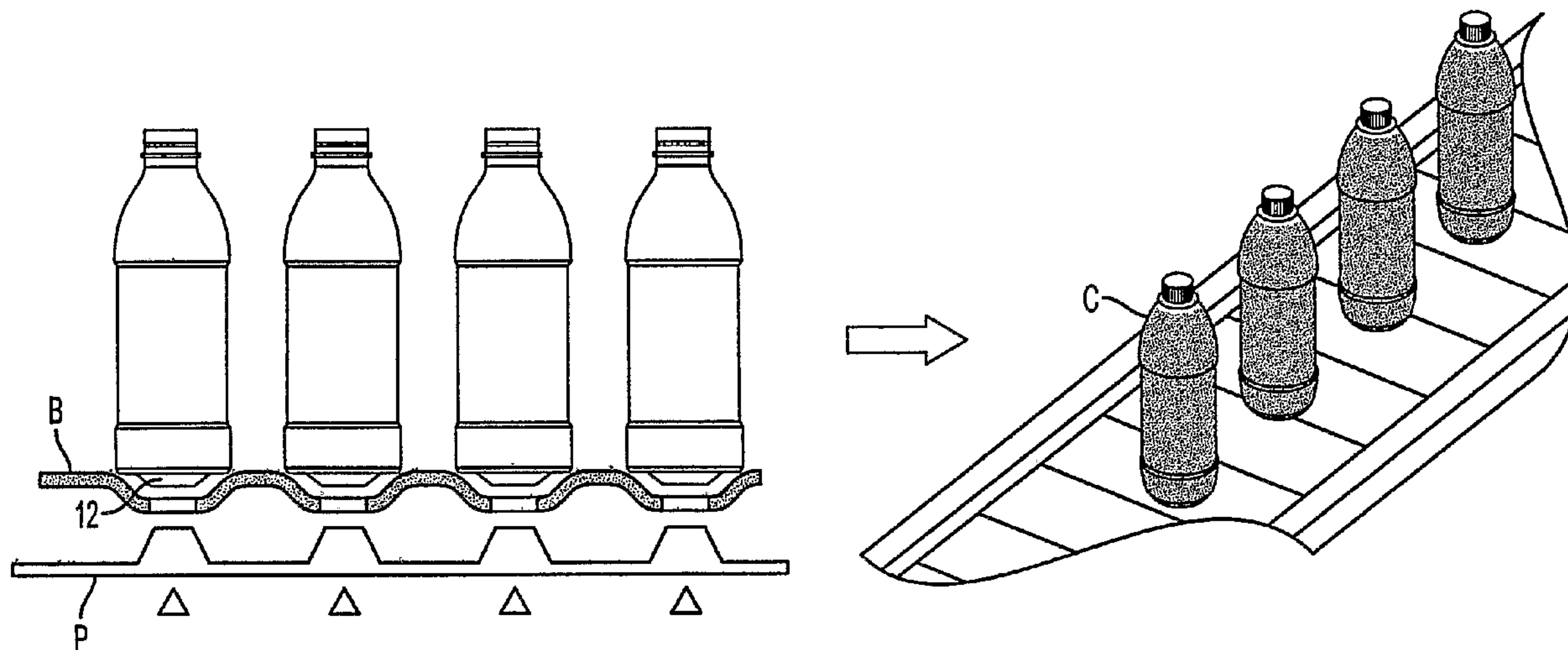

(57) Abrégé/Abstract:

A system for processing a simplified plastic container (C) that is to be filled with a hot product includes the step of blow-molding parison to form a container body, where the container body has a neck, a base, a side surface relatively free of structural geometry that surrounds an interior of the container body and, prior to being filled with the hot product, a projection (12) extending from the container body. After the container body is filled with a hot product in a production line, the neck of the filled container body is capped with a cap and then, the container body is cooled. During the cooling operation, the hot product is contracted so that the projection extending from the container can be pushed (P) into the container body like a traditional push-up so that the resultant, filled and cooled container body is relatively free of structural geometry.

(12) INTERNATIONAL APPLICATION PUBLISHED UNDER THE PATENT COOPERATION TREATY (PCT)

(19) World Intellectual Property
Organization
International Bureau



(43) International Publication Date
10 February 2005 (10.02.2005)

PCT

(10) International Publication Number
WO 2005/012091 A3

- (51) International Patent Classification⁷: **B67C 3/14**, B65D 79/00, 1/02, B65B 63/08
- (74) Agents: **VOORHEES, Catherine, M.** et al.; Venable LLP, P.O. Box 34345, Washington, District of Columbia 20043-9998 (US).
- (21) International Application Number: PCT/US2004/024581
- (22) International Filing Date: 30 July 2004 (30.07.2004)
- (25) Filing Language: English
- (26) Publication Language: English
- (30) Priority Data:
60/491,179 30 July 2003 (30.07.2003) US
60/551,771 11 March 2004 (11.03.2004) US
- (71) Applicant (for all designated States except US): **GRAHAM PACKAGING COMPANY, L.P.** [US/US]; 2401 Pleasant Valley Road, York, Pennsylvania 17402 (US).
- (72) Inventors; and
- (75) Inventors/Applicants (for US only): **KELLEY, Paul** [US/US]; 42 Catocin Highlands Circle, Thurmont, Maryland 21788 (US). **GOSS, Kent** [US/US]; 8942 West 311th Street, Louisburg, Kansas 66053-6903 (US). **SHEETS, Philip** [US/US]; 2401 Pleasant Valley Road, York, Pennsylvania 17492 (US). **LYON, Ted** [US/US]; 2401 Pleasant Valley Road, York, Pennsylvania 17402 (US). **RYL-KUCHAR, Charles, A.** [US/US]; 14802 Copper Penny Drive, Granger, Indiana 46530 (US).
- (81) Designated States (unless otherwise indicated, for every kind of national protection available): AE, AG, AL, AM, AT, AU, AZ, BA, BB, BG, BR, BW, BY, BZ, CA, CH, CN, CO, CR, CU, CZ, DE, DK, DM, DZ, EC, EE, EG, ES, FI, GB, GD, GE, GH, GM, HR, HU, ID, IL, IN, IS, JP, KE, KG, KP, KR, KZ, LC, LK, LR, LS, LT, LU, LV, MA, MD, MG, MK, MN, MW, MX, MZ, NA, NI, NO, NZ, OM, PG, PH, PL, PT, RO, RU, SC, SD, SE, SG, SK, SL, SY, TJ, TM, TN, TR, TT, TZ, UA, UG, US, UZ, VC, VN, YU, ZA, ZM, ZW.
- (84) Designated States (unless otherwise indicated, for every kind of regional protection available): ARIPO (BW, GH, GM, KE, LS, MW, MZ, NA, SD, SL, SZ, TZ, UG, ZM, ZW), Eurasian (AM, AZ, BY, KG, KZ, MD, RU, TJ, TM), European (AT, BE, BG, CH, CY, CZ, DE, DK, EE, ES, FI, FR, GB, GR, HU, IE, IT, LU, MC, NL, PL, PT, RO, SE, SI, SK, TR), OAPI (BF, BJ, CF, CG, CI, CM, GA, GN, GQ, GW, ML, MR, NE, SN, TD, TG).

Declarations under Rule 4.17:

- as to applicant's entitlement to apply for and be granted a patent (Rule 4.17(ii)) for the following designations AE, AG, AL, AM, AT, AU, AZ, BA, BB, BG, BR, BW, BY, BZ, CA, CH, CN, CO, CR, CU, CZ, DE, DK, DM, DZ, EC, EE, EG, ES, FI, GB, GD, GE, GH, GM, HR, HU, ID, IL, IN, IS,

[Continued on next page]

(54) Title: CONTAINER HANDLING SYSTEM

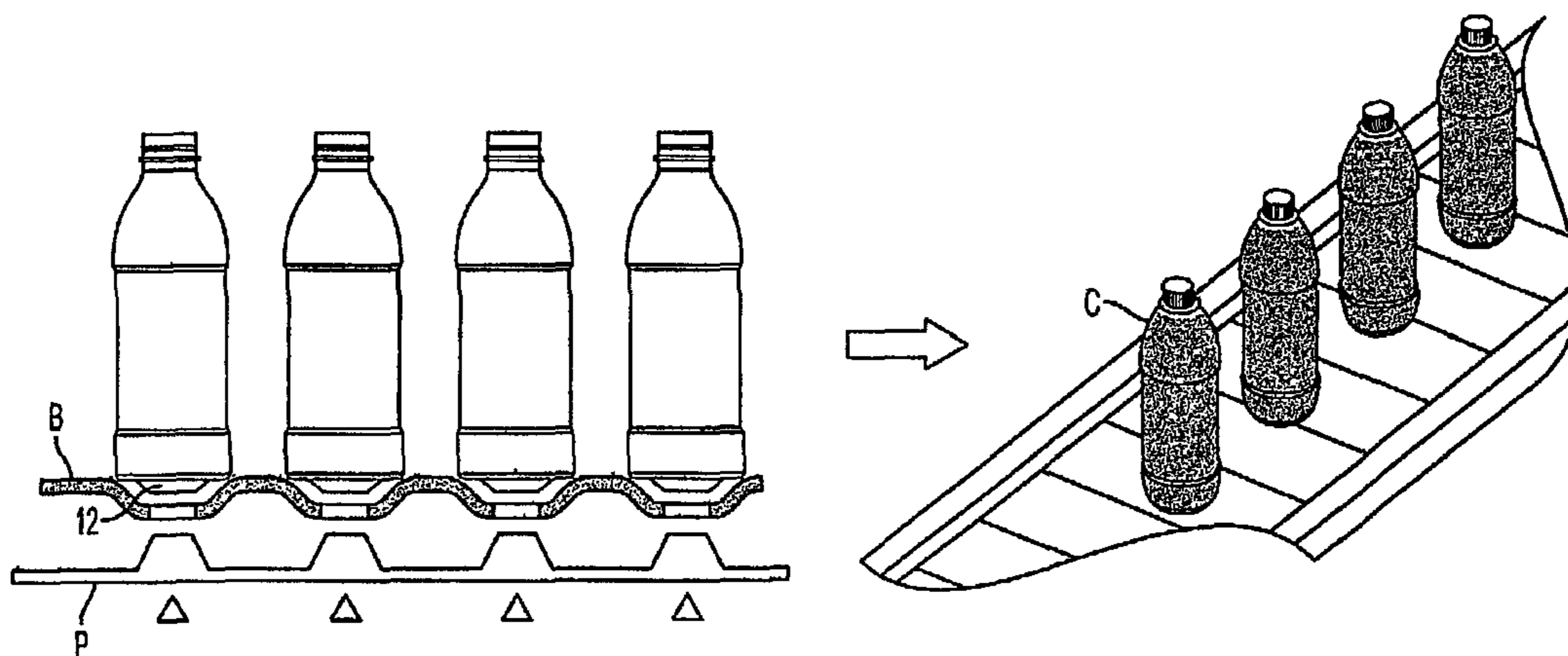

(57) Abstract: A system for processing a simplified plastic container (C) that is to be filled with a hot product includes the step of blow-molding parison to form a container body, where the container body has a neck, a base, a side surface relatively free of structural geometry that surrounds an interior of the container body and, prior to being filled with the hot product, a projection (12) extending from the container body. After the container body is filled with a hot product in a production line, the neck of the filled container body is capped with a cap and then, the container body is cooled. During the cooling operation, the hot product is contracted so that the projection extending from the container can be pushed (P) into the container body like a traditional push-up so that the resultant, filled and cooled container body is relatively free of structural geometry.

WO 2005/012091 A3

JP, KE, KG, KP, KR, KZ, LC, LK, LR, LS, LT, LU, LV, MA, MD, MG, MK, MN, MW, MX, MZ, NA, NI, NO, NZ, OM, PG, PH, PL, PT, RO, RU, SC, SD, SE, SG, SK, SL, SY, TJ, TM, TN, TR, TT, TZ, UA, UG, UZ, VC, VN, YU, ZA, ZM, ZW, ARIPO patent (BW, GH, GM, KE, LS, MW, MZ, NA, SD, SL, SZ, TZ, UG, ZM, ZW), Eurasian patent (AM, AZ, BY, KG, KZ, MD, RU, TJ, TM), European patent (AT, BE, BG, CH, CY, CZ, DE, DK, EE, ES, FI, FR, GB, GR, HU, IE, IT, LU, MC, NL, PL, PT, RO, SE, SI, SK, TR), OAPI patent (BF, BJ, CF, CG, CI, CM, GA, GN, GQ, GW, ML, MR, NE, SN, TD, TG)

- *as to the applicant's entitlement to claim the priority of the earlier application (Rule 4.17(iii)) for all designations*

Published:

- *with international search report*
- *before the expiration of the time limit for amending the claims and to be republished in the event of receipt of amendments*

(88) Date of publication of the international search report:

9 September 2005

For two-letter codes and other abbreviations, refer to the "Guidance Notes on Codes and Abbreviations" appearing at the beginning of each regular issue of the PCT Gazette.

CONTAINER HANDLING SYSTEM

BACKGROUND OF THE INVENTION

Field of the Invention

The present invention relates generally to a container handling system and a process for filling, capping and cooling hot-filled containers with a projection, and more particularly to a system and process for filling, capping and cooling hot-filled, blow-molded containers with a projection that can extend outside the container during the filling process and be inverted inside the container before the filled container is removed from a production line.

Related Art

Known blow-molded containers are usually made of plastic and employ flex panels that reinforce the integrity of the container while accommodating internal changes in pressures and volume in the container as a result of heating and cooling. This is especially true with hot-fillable containers, or containers in which hot products are injected during a filling process, capped and cooled to room temperature thereby allowing the filled product to cool to the ambient room temperature. Such containers are disclosed in U.S. Patent Nos. 6,298,638, 6,439,413, and 6,467,639 assigned to Graham Packaging Company, all of which are incorporated by reference herein.

In order to obtain the necessary strength associated with glass containers, known hot-filled containers made out of plastic tend to be formed with protruding rib structures that surround panels forming the container. While the protruding rib structures improve the strength of the container that is blow-molded out of plastic, the resultant, lightweight, blow-molded containers with panels and protruding rib structure detract from the desired smooth, sleek look of a glass container. Accordingly, a hot-fillable, blow-molded container and process of filling, capping and cooling the same is needed that more closely simulates a glass container and achieves the smooth outward appearance associated with glass containers.

In addition to having protruding rib structures for strength, known hot-filled plastic containers tend to have rectangular panels for vacuum compensation. For example, conventional hot-fill containers, depending upon the size, may have 6 vacuum or flex panels to take up the resultant vacuum after cooling the hot-filled product with rigid, structural columns or ribs between each vacuum panel. It is

known in the art to cover the protruding rib structures and panels with a paper label to improve the aesthetics or overall appearance of the plastic container. Consequently, in order to provide support for the label, the panels of such containers are provided with additional protruding structures. Thus, hot-filled containers are provided with more recesses and corners from which hot-filled solid products are not easily removed. Or, if the hot-filled product is subsequently chilled by placing the container in ice, the label covering the panels with protruding structures traps water inside the recessed panels resulting in spillage of the water after the container is removed from ice. Accordingly, a hot-filled, plastic container with a smoother side surface that is relatively or completely free of structural geometry is desired to overcome the shortcomings of the prior art.

BRIEF SUMMARY OF THE INVENTION

A three stage system utilizes a simplified, blow-molded container that retains its structural integrity after being hot filled and cooled through conventional food or beverage systems. That is, a simplified container according to the invention is a container with at least a portion of the container side walls being relatively smooth that can be filled with a hot product, such as a liquid or a partly solid product, and retain the requisite strength so that a number of containers can be stacked on top of one another with the resultant stack being sturdy. The relatively smooth surface is relatively or completely free of structural geometry, such as the structural ribs, riblets, or vacuum panels. In addition, the simplified, blow-molded container still retains the features of vacuum packaging and the ability to accommodate internal changes in pressure and volume as a result of heating and cooling. That is, the simplified container may employ a single main invertible projection by itself to take up the vacuum; or, the simplified container may have a few main projections that take up the vacuum while still providing a substantial portion of the container to be relatively smooth for label placement, for example. Alternatively, depending upon the size of the container, a mini vacuum panel to supplement the main invertible projection may be used to complete the removal of the resultant vacuum and finish the look of the cooled container. Unlike conventional containers, structural ribs between vacuum panels

are not necessary in a simplified container where a substantial portion of the container body is relatively smooth.

Initially, a container is blow-molded with an approximately polygonal, circular or oval projection extending, for example, from a base of the container.

5 The approximately polygonal, circular or oval projection may project from the shoulders of the container, or from another area of the container. If the projection extends from the base of the container, before the container exits the blow-molding operation, the projection may be inverted inside the container so that the base surface of the blow-molded container is relatively flat so that the container
10 can be easily conveyed on a table top, without toppling.

In the next stage, the blow-molded container may be picked-up by a robotic arm or the like and placed into a production line conveyor where it is supported by its neck. A mechanical operation causes a rod to be inserted in the neck of the container and pushes the inverted projection outside the container to
15 provide for the increased volume necessary to receive a hot-filled product, as well as accommodating variations in pressure due to temperature changes during cooling. Alternatively, compressed air or other pressure may be used to push the inverted projection outside of the container. With the projection extending outside the container, the container is filled with a hot product, capped and moved to the
20 cooling operation. Since the container is supported by its neck during the filling and capping operations, the process according to the invention provides maximum control of the containers while being filled and capped.

The third stage of the operation may divide the filled and capped containers into different lanes and then the containers may be positioned in a rack
25 or basket before entering the cooler for the cooling of the hot-filled product. It is envisioned that a robotic arm may lift the filled and capped container with the projection extending from the container into a rack or basket. If the projection extends from the base of the container, the basket or rack is provided with an opening for receiving the projection and or enabling the container to stand upright.

30 The container-filled basket or rack is then conveyed through a cooling system to bring the temperature of the hot-filled container to room temperature.

As the hot-filled product in the container is cooled to room temperature, the container becomes distorted as a vacuum is created in an area where the once hot product filled a portion of the container. Thus, there is no longer a need for the increased volume obtained by the projection extending from the container. In addition, the cooled, distorted container needs to be reformed to the aesthetic original container shape. Accordingly, it is now possible to return the containers to the desired aesthetic shape obtained after the cool-down contraction of the product by an activator that pushes against the extending projections while the containers are held in place thereby pushing the projection inside the container in an inverted state. This inverted state may be the same inverted state achieved before exiting the blow-molding operation.

The activator, according to one embodiment of the invention, may be a relatively flat piece of material with approximately polygonal or circular projections extending therefrom at intervals corresponding to openings of a basket that receive the container projections. The activator may be a panel that can invert projections of a single row of containers in the basket. Or, the activator may have several rows of polygonal or circular projections so that an entire basket of containers with projections can be inverted with one upward motion of the activator. While the preceding embodiment describes an activator for inverting projections extending from the base of a container, other activators for inverting projections extending from the shoulders or other areas of the container are envisioned. The activator panel can be made out of heavy plastic, metal or wood. The action of inverting the extending projection absorbs the space of the vacuum created by the cooling operation and provides all the vacuum compensation necessary for the cooled, product-filled container.

This invention satisfies a long felt need for a plastic, blow-molded container having a smooth outward appearance similar to that of a heavier glass container.

A system for manufacturing a simplified plastic container that is to be filled with a hot product, comprising the steps of blow-molding parison to form a container body, the container body having a neck, a base, a smooth side surface surrounding an interior of the container body and a projection extending from the container; filling the container body with the hot product in a production line;

capping the neck of the filled container body with a cap in the next operation of the production line; cooling the container body filled with the hot product; and pushing the projection extending from the cooled container body into the interior of the container body so that the resultant, filled and cooled container body is
5 relatively flat. If the projection extends from a base of the container, this inversion permits conveying of the container body on its base.

Further objectives and advantages, as well as the structure and function of preferred embodiments will become apparent from a consideration of the description, drawings, and examples.

10 **BRIEF DESCRIPTION OF THE DRAWINGS**

The foregoing and other features and advantages of the invention will be apparent from the following, more particular description of a preferred embodiment of the invention, as illustrated in the accompanying drawings wherein like reference numbers generally indicate identical, functionally similar, and/or
15 structurally similar elements.

FIG. 1 A schematically depicts containers according to the invention leaving the blow-molding operation;

FIG. 1B illustrates an embodiment of a plastic, blow-molded container with a smooth surface according to the invention;

20 FIG. 2 schematically depicts containers being filled and capped;

FIGS. 3A and B depict exemplary channeling of containers into baskets or racks according to the present invention for the cooling operation;

FIG. 4 depicts an exemplary flow of racked containers in a cooler according to the present invention;

25 FIGS. 5 A-C schematically illustrate one embodiment of an activation operation according to the invention;

FIG. 6 schematically depicts an exemplary embodiment of containers exiting the cooling operation, after the activation operation according to the present invention;

30 FIG. 7 is a schematic plan view of an exemplary handling system that combines single containers with a container holding device according to the invention;

FIG. 8 is a front side elevation view of the handling system of FIG. 7;

FIG. 9 is an unfolded elevation view of a section of the combining portion of the handling system of FIG. 8 illustrating the movement of the actuators;

FIG. 10 is a schematic plan view of a second embodiment of an activation
5 portion of the handling system of the present invention;

FIG. 11 is a detailed plan view of the activation portion of the handling system of FIG. 10;

FIG. 12 is an unfolded elevation view of a section of the activation portion of FIG. 10 illustrating the activation of the container and the removal of the
10 container from the container holding device;

FIG. 13 is an enlarged view of a section of the activation portion of FIG. 12; and

FIG. 14 is an enlarged view of the container holder removal section of FIG. 12.

15 **DETAILED DESCRIPTION OF THE INVENTION**

Embodiments of the invention are discussed in detail below. In describing embodiments, specific terminology is employed for the sake of clarity. However, the invention is not intended to be limited to the specific terminology so selected. While specific exemplary embodiments are discussed, it should be understood that this is
20 done for illustration purposes only. A person skilled in the relevant art will recognize that other components and configurations can be used without parting from the spirit and scope of the invention. All references cited herein are incorporated by reference as if each had been individually incorporated.

As shown schematically in Figure 1A, containers C formed in a blow-
25 molding or forming operation may exit the blow-molding operation with a base designed so that the container can stand on its own. That is, a container with a relatively smooth side surrounding its interior may be blow-molded with a projection extending from the base of the smooth sided container, and before the blow-molded container leaves the blow-molding operation, the projection of the
30 base may be inverted inside the interior of the container so that the resultant base surface of the container can easily be conveyed in a table top manner. As shown in Figure 1, the blow-molded containers may be placed in shipping containers 10

or on pallets with, for example, 24 columns and 20 rows so that each rack carries 480 bottles or containers. The inverted blow-molded projection can be designed so that the finish or neck area of a container can securely rest within the inverted blow-molded projection. As a result, the pallets holding the containers can be
5 stacked for easier transportation to an operation that fills, caps and then cools the filled containers.

As shown in Figure 1B, the blow-molded containers may be smooth cylinders on the outside without the vacuum compression panels previously considered necessary on the side of the container, which detracted from the sleek
10 appearance of the container and provided recesses for gathering product or ice water. These blow-molded containers are preferably made of plastic, such as a thermoplastic polyester resin, for example PET (polyethylene terephthalate) or polyolefins, such as PP and PE. Each container is blow-molded and formed with an approximately polygonal, circular or oval projection 12 that extends from its
15 base during the initial blow-mold operation. In the exemplary embodiment, the relatively smooth side surface of the container may taper slightly in the mid-section of the container to provide an area to place a label. In another embodiment of such a blow-molded container, the smooth side surface may not be formed with the slight depressed area if the label is printed on the container, for example.
20 Alternatively, the relatively smooth surface may have ornamental features (e.g., textures).

In the case of larger containers (e.g., 64oz.), a container may be formed with a grip panel on a portion of the cylindrical body of the container. Thus, Applicants envision simplified containers where a substantial portion of the
25 cylindrical body is relatively or completely free of structural geometry. An invertible projection may be formed at the base of the container. The invertible projection may take up most of the vacuum bringing the cooled hot-filled container to its aesthetic appearance. It is envisioned that mini or supplemental vacuum panels may be necessary to complete the removal of the vacuum in larger
30 containers. These mini or supplemental vacuum panels may be incorporated in the grip panel or at an area that does not interfere with the positioning of a label.

Grip panels are disclosed, for example, in U.S. Patents Nos. 6,375,025; 5,392,937; 6,390,316; and 5,598,941. Many of the grip panels disclosed in the prior art may also serve as vacuum relief or flex panels. Utilizing the present invention, it is not necessary for the grip panel to act as a vacuum relief panel and the design may therefore be simplified. That is, the ribbed structure associated with the flex panel may not be necessary, or label panel support ribs may be reduced or eliminated. Persons of ordinary skill in the art will be able to modify or simplify known grip panels for use with the present invention.

The base of a blow-molded container, according to one embodiment of the invention, has an inversion or standing ring 14 adjacent a tapered area of the smooth side surface and inside the inversion ring is a substantially smooth projection 12 that extends approximately from a center of the base. The size and shape of the projection 12 depends upon the size and shape of the container that is formed during the blow-molding operation, as well as the contraction properties of the contained product. Prior to leaving the blow-molding operation, the projection may be forced inside the container to provide a relatively flat surface at the container's base, or a stable base for the container. This inversion of the projection 12 extending from the base of the blow-molded container may be accomplished by pneumatic or mechanical means.

In this manner, as best seen in FIG. 7, containers C can be conveyed singularly to a combining system that combines container holding devices and containers. The combining system of FIG. 7 includes a container in-feed 18a and a container holding device in-feed 20. As will be more fully described below, this system may be one way to stabilize containers with projected bottom portions that are unable to be supported by their bottom surfaces alone. Container in-feed 18a includes a feed scroll assembly 24, which feeds and spaces the containers at the appropriate spacing for merging containers C into a feed-in wheel 22a. Wheel 22a comprises a generally star-shaped wheel, which feeds the containers to a main turret system 30 and includes a stationary or fixed plate 23a that supports the respective containers while containers C are fed to turret system 30, where the containers are matched up with a container holding device H and then deactivated to have a projecting bottom portion.

Similarly, container holding devices H are fed in and spaced by a second feed scroll 26, which feeds in and spaces container holding devices H to match the spacing on a second feed-in wheel 28, which also comprises a generally star-shaped wheel. Feed-in wheel 28 similarly includes a fixed plate 28a for supporting container holding devices H while they are fed into turret system 30. Container holding devices H are fed into main turret system 30 where containers C are placed in container holding devices H, with holding devices H providing a stable bottom surface for processing the containers. In the illustrated embodiment, main turret system 30 rotates in a clock-wise direction to align the respective containers over the container holding devices fed in by star wheel 28. However, it should be understood that the direction of rotation may be changed. Wheels 22a and 28 are driven by a motor 29 (FIG. 8), which is drivingly coupled, for example, by a belt or chain or the like, to gears or sheaves mounted on the respective shafts of wheels 22a and 28.

Container holding devices H comprise disc-shaped members with a first recess with an upwardly facing opening for receiving the lower end of a container and a second recess with downwardly facing opening, which extends upwardly from the downwardly facing side of the disc-shaped member through to the first recess to form a transverse passage through the disc-shaped member. The second recess is smaller in diameter than the first so as to form a shelf in the disc-shaped member on which at least the perimeter of the container can rest. As noted above, when a container is deactivated, its vacuum panels will be extended or projecting from the bottom surface. The extended or projecting portion is accommodated by the second recess. In addition, the containers can then be activated through the transverse passage formed by the second recess, as will be appreciated more fully in reference to FIGS. 5A-C and 12-13 described below.

In order to provide extra volume and accommodation of pressure changes needed when the containers are filled with a hot product, such as a hot liquid or a partly solid product, the inverted projection of the blow-molded containers should be pushed back out of the container (deactivated). For example, a mechanical operation employing a rod that enters the neck of the blow-molded container and pushes against the inverted projection of the blow-molded container causing the

inverted projection to move out and project from the bottom of the base, as shown in Figures 1B, 5C and 12-13. Alternatively, other methods of deploying the inverted projection disposed inside a blow-molded container, such as injecting pressurized air into the blow-molded container, may be used to force the inverted projection outside of the container. Thus, in this embodiment, the blow-molded projection is initially inverted inside the container and then, a repositioning operation pushes the inverted projection so that it projects out of the container.

Referring to FIG. 8, main turret system 30 includes a central shaft 30a, which supports a container carrier wheel 32, a plurality of radially spaced container actuator assemblies 34 and, further, a plurality of radially spaced container holder actuator assemblies 36 (FIG. 9). Actuator assemblies 34 deactivate the containers (extend the inverted projection outside the bottom surface of the container), while actuator assemblies 36 support the container holding devices and containers. Shaft 30a is also driven by motor 29, which is coupled to a gear or sheave mounted to shaft 30a by a belt or chain or the like. In addition, main turret system 30 includes a fixed plate 32a for supporting the containers as they are fed into container carrier wheel 32. However, fixed plate 32a terminates adjacent the feed-in point of the container holding devices so that the containers can be placed or dropped into the container holding devices under the force of gravity, for example. Container holding devices H are then supported on a rotating plate 32b, which rotates and conveys container holding devices H to discharge wheel 22b, which thereafter feeds the container holding devices and containers to a conveyor 18b, which conveys the container holding devices and containers to a filling system. Rotating plate 32b includes openings or is perforated so that the extendable rods of the actuator assemblies 36, which rotate with the rotating plate, may extend through the rotating plate to raise the container holding devices and containers and feed the container holding devices and containers to a fixed plate or platform 23b for feeding to discharge wheel 22b.

As best seen in FIG. 9, each actuator assembly 34, 36 is positioned to align with a respective container C and container holding device H. Each actuator assembly 34 includes an extendable rod 38 for deactivating containers C, as will be described below. Each actuator assembly 36 also includes an extendable rod 40

and a pusher member 42, which supports a container holding device, while a container C is dropped into the container holding device H and, further supports the container holding device H while the container is deactivated by extendable rod 38. To deactivate a container, actuator assembly 34 is actuated to extend its extendable rod 38 so that it extends into the container C and applies a downward force onto the invertible projection (12) of the container to thereby move the projection to an extended position to increase the volume of container C for the hot-filling and post-cooling process that follows (Fig. 1B). After rod 38 has fully extended the invertible projection of a container, rod 38 is retracted so that the container holding device and container may be conveyed for further processing.

Again as best seen in FIG. 9, while rod 38 is retracted, extendable rod 40 of actuator 36 is further extended to raise the container holding device and container to an elevation for placement on fixed plate or platform 23b of discharge wheel 22b. Wheel 22b feeds the container holding device and container to an adjacent conveyor 18b, which conveys the container holding device and container to filling portion 16 of the container processing system. Discharge wheel 22b is similar driven by motor 29, which is coupled to a gear or sheave mounted on its respective shaft.

Referring again to FIGS. 8 and 9, main turret assembly 30 includes an upper cam assembly 50 and a lower cam assembly 52. Cam assemblies 50 and 52 comprise annular cam plates that encircle shaft 30a and actuator assemblies 34 and 36. The cam plates provide cam surfaces to actuate the actuator assemblies, as will be more fully described below. Upper cam assembly 50 includes upper cam plate 54 and a lower cam plate 56, which define there between a cam surface or groove 58 for guiding the respective extendable rods 38 of actuator assemblies 34. Similarly, lower cam assembly 52 includes a lower cam plate 60 and an upper cam plate 62 which define there between a cam surface or groove 64 for guiding extendable rods 40 of actuator assemblies 36. Mounted to extendable rod 38 may be a guide member or cam follower, which engages cam groove or surface 58 of upper cam assembly 50. As noted previously, actuator assemblies 34 are mounted in a radial arrangement on main turret system 30 and, further, are rotatably mounted such that actuator assemblies 34 rotate with shaft 30a and container

holder wheel 32. In addition, actuator assemblies 34 may rotate in a manner to be synchronized with the in-feed of containers C. As each of the respective actuator assemblies 34 is rotated about main turret system 30 with a respective container, the cam follower is guided by groove 58 of cam assembly 50, thereby raising and lowering extendable member 38 to deactivate the containers, as previously noted, after the containers are loaded into the container holding devices.

If the container holding devices are not used, the containers according to the invention may be supported at the neck of each container during the filling and capping operations to provide maximum control of the container processes. This may be achieved by rails R, which support the neck of the container, and a traditional cleat and chain drive, or any other known like-conveying modes for moving the containers along the rails R of the production line. The extendable projection 12 may be positioned outside the container C by an actuator as described above.

The process of repositioning the projection outside of the container preferably should occur right before the filling of the hot product into the container. According to one embodiment of the invention, the neck of a container would be sufficiently supported by rails so that the repositioning operation could force or pop the inverted base outside of the container without causing the container to fall off the rail conveyor system. In some instances, it may not be necessary to invert the projection prior to leaving the blow-molding operation and these containers are moved directly to a filling station. The container with an extended projection, still supported by its neck, may be moved by a traditional neck rail drive to the filling and capping operations, as schematically shown in Figure 2.

As shown in Figure 3A, the system for conveying the filled containers may include dividing the single filling and capping rail R into a plurality of rail lanes RL that feed into a shuttle basket B or rack system. The continuous batch mode handling of the containers into the cooling baskets or racks provides total control of the containers/package throughout the cooling cycle. As shown in Figure 3B, baskets or racks are mechanically fed into a lane where the basket or rack receives hot-filled containers with the extending projections from each of the plurality of

rail lanes, until the basket is full. After the basket or rack is full of filled containers, it is moved for example, perpendicularly away from the direction of basket or rack feed toward a cooler. The shuttle basket or rack system may be driven through a traditional container cooler via a cleat and chain drive, for
5 example.

In one embodiment, the basket may have a gate, which swings down from its upward position in order to allow containers C with the extending projection 12 to enter the basket. In that the hot-filled containers have projections extending from their base, the rail lanes and basket may be controlled in a sequence to fill the
10 basket or rack with containers. For example, the basket or rack would have a plurality of openings for receiving respective projections of the hot-filled containers. Either robotic arms and/or the rail lanes would lift a row of hot-filled containers with extending projections over the gate and into respective openings of the basket. The basket would move away from its initial fed position exposing
15 another row of openings for receiving hot-filled containers and then that row would be filled with the containers with the extending projections. This process would continue so that the entire basket could receive hot-filled containers.

The handling of the filled and capped containers with extending projections would also be sequenced so that there would be room underneath the
20 rail lanes to feed the basket or rail. Thus, the basket could be positioned initially so that a container fed down each rail lane could be lifted into a respective opening of the basket. The basket would move to the left, as shown in Figure 3B, and then the next row of containers would be fed down each rail lane and then lifted into the second row openings of the basket or rail. Alternatively, the basket or
25 racks could be fed into their position and a robotic arm of the rail lanes could pick up each container and place the same in a respective opening of the basket or rack.

After the basket is full of hot-filled containers, the gate would swing upwards and lock onto the side of the basket and then the basket would move toward the cooler C. Thus, according to the invention, the handling system
30 provides lane control to align the containers before they are placed in the basket or rack system. Figure 4 illustrates how a shuttle basket B or rack system may travel

through a traditional cooler, which may have ambient air or coolant blowing against the hot-filled containers to cool their contents to room temperature.

After the containers and their contents have been cooled during the cooling operation, the cooled product has contracted and thus an extra amount of volume exists in these cooled containers. However, the cooling operation also induces a vacuum in each container which distorts each container thereby lessening the amount of volume in the container. Since the projection extending from the base of the container is no longer necessary and a relatively flat base surface is desired, each shuttle basket or rack enters an activation operation, which reforms the containers from the induced vacuum caused by the cooled down contraction of the product within the containers to aesthetic containers. The basket or racks provide location and control of the containers during the activation step at the end of the cooling cycle.

As schematically shown in Figures 5A-C, the activation operation is achieved by placing a panel P with a number of projections corresponding to the projections extending from the containers underneath a container-filled basket B or rack. The panel and projections may rest underneath a single row or column of the containers in the basket or rack. Or, the panel and associated projections may be larger extending over two or more row or columns. An arm or cover (not shown) is placed over the containers to be activated. Then, the panel is moved upward towards the projections with sufficient force to push the projections back to their inverted position inside a respective container, like a traditional push-up. Thus, the extending projection is moved back inside the container body or re-inverted inside the container. The arm or cover placed over the containers holds the containers in place when the force of the activator panel is applied against the containers. It is envisioned that a panel the size of the basket or rack and with respective projections that extend to each of the openings of the basket or rack could invert the projecting base of the container inside each opening in the basket or rack, if the force applied to the panel is sufficient to pop the projecting bases back into the container.

In an exemplary embodiment, the activation step would occur at the end of the cooling cycle and would absorb or counter the vacuum created during the

cooling of the hot product. Once the base projections have been re-inverted so that each base surface is relatively flat, the containers may be unloaded from the basket or racks that shuttle the containers through the cooler. As schematically shown in Figure 6, at the cooling exit, a robotic arm RA may lift the containers at their capped neck vertically upwards and then out of the basket B or rack. The containers with the inverted bases would then be released from the robotic arm and sent down another conveying line like a normally filled bottle or container. The conveying line could be an in-line rail belt or could be an in-line conveying system using air to control the movement of the containers. The conveying line may feed the containers to a labeling operation and then to a packaging operation where the containers are loaded into cases for shipping to a grocery store or the like.

In an alternative operation, it is envisioned that containers would continue along the production line from the filling station, the capping station and through a cooling station. That is, instead of queuing up the containers for placement in a basket or rack for the cooling operation, each container would move along a production conveyor line. After each container passed through a cooling station, an activator would force the projecting base into the interior of the container. In a similar alternative embodiment where containers are individually passed through the cooling station, the cooled containers are then re-inverted as previously described. Then, the activated containers could be placed in conventional baskets or racks.

Referring to FIGS. 10 and 11, one system for singularly activating containers C includes a feed-in scroll assembly 84, which feeds and, further, spaces the respective container holding devices and their containers at a spacing appropriate for feeding into a feed-in wheel 86. Feed-in wheel 86 is of similar construction to wheel 22b and includes a generally star-shaped wheel that feeds-in the container holders and containers to turret assembly 88. Turret assembly 88 is of similar construction to turret assembly 30 and includes a container holder wheel 90 for guiding and moving container holding devices H and containers C in a circular path and, further, a plurality of actuator assemblies 104 and 106 for removing the containers from the container holders and for activating the

respective containers, as will be more fully described below. After the respective containers have been activated and the respective containers removed from the container holding devices, the holders are discharged by a discharge wheel 92 to conveyor 94 and the containers are discharged by a discharge wheel 96 to a conveyor 98 for further processing. Wheels 86, 92, and 96 may be driven by a common motor, which is drivingly coupled to gears or sheaves mounted to the respective shafts of wheels 86, 92, and 96.

As previously noted, turret assembly 88 is of similar construction to turret assembly 30 and includes container holder wheel 90, upper and lower cam assemblies 100 and 102, respectively, a plurality of actuator assemblies 104 for gripping the containers, and a plurality of actuator assemblies 106 for activating the containers. In addition, turret system 88 includes a support plate 107, which supports the container holders and containers as they are moved by turret system 88. As best seen in FIG. 11, container holder wheel 90, actuator assemblies 104, actuator assemblies 106, and plate 107 are commonly mounted to shaft 88a so that they rotate in unison. Shaft 88a is similarly driven by the common motor, which is drivingly coupled to a gear or sheave mounted on shaft 88a.

Looking at FIGS 12-14, actuator assemblies 104 and 106 are similarly controlled by upper and lower cam assemblies 100 and 102, to remove the containers C from the container holding devices H and activate the respective containers so that the containers generally assume their normal geometrically stable configuration wherein the containers can be supported from their bottom surfaces and be conveyed on a conventional conveyor. Referring to FIG. 12, each actuator assembly 104 includes actuator assembly 34 and a container gripper 108 that is mounted to the extendable rod 38 of actuator assembly 34. As would be understood, grippers 108 are, therefore, extended or retracted with the extension or retraction of extendable rods 38, which is controlled by upper cam assembly 100.

Similar to upper cam assembly 50, upper cam assembly 100 includes an upper plate 110 and a lower plate 112, which define therebetween a cam surface or recess 114, which guides guide members 72 of actuator assemblies 104 to thereby extend and retract extendable rods 38 and in turn to extend and retract container grippers 108. As the containers are conveyed through turret assembly 88, a

respective gripper 108 is lowered onto a respective container by its respective extendable rod 38. Once the gripper is positioned on the respective container, actuator assemblies 106 are then actuated to extend their respective extendable rods 116, which extend through plate 107 and holders H, to apply a compressive
5 force onto the invertible projections of the containers to move the projections to their recessed or retracted positions to thereby activate the containers. As would be understood, the upward force generated by extendable rod 116 is counteracted by the downward force of a gripper 108 on container C. After the activation of each container is complete, the container then can be removed from the holder by its
10 respective gripper 108.

Referring to FIGS. 12-13, each actuator assembly 106 is of similar construction to actuator assemblies 34 and 36 and includes a housing 120, which supports extendable rod 116. Similar to the extendable rods of actuator assemblies 34 and 36, extendable rod 116 includes mounted thereto a guide 122, which
15 engages the cam surface or recess 124 of lower cam assembly 102. In this manner, guide member 122 extends and retracts extendable rod 116 as it follows cam surface 124 through turret assembly 88. As noted previously, when extendable rod 116 is extended, it passes through the base of container holding device H to extend and contact the lower surface of container C and, further, to apply a force
20 sufficient to compress or move the invertible projection its retracted position so that container C can again resume its geometrically stable configuration for normal handling or processing.

The physics of manipulating the activation panel P or extendable rod 116 is a calculated science recognizing 1) Headspace in a container; 2) Product density
25 in a hot-filled container; 3) Thermal differences from the fill temperature through the cooler temperature through the ambient storage temperature and finally the refrigerated temperature; and 4) Water vapor transmission. By recognizing all of these factors, the size and travel of the activation panel P or extendable rod 116 is calculated so as to achieve predictable and repeatable results. With the vacuum
30 removed from the hot-filled container, the container can be light-weighted because the need to add weight to resist a vacuum or to build vacuum panels is no longer

necessary. Weight reduction of a container can be anticipated to be approximately 10%.

5 The embodiments illustrated and discussed in this specification are intended only to teach those skilled in the art the best way known to the inventors to make and use the invention. Nothing in this specification should be considered as limiting the scope of the present invention. All examples presented are representative and non-limiting. The above-described embodiments of the invention may be modified or varied, without departing from the invention, as appreciated by those skilled in the art in light of the above teachings. It is therefore to be understood that, within the scope
10 of the claims and their equivalents, the invention may be practiced otherwise than as specifically described.

WHAT IS CLAIMED IS:

1. A system for processing a plastic container filled with a hot product, comprising:

means for filling a container body with the hot product in a production line, the container body having a surface surrounding an interior of the container body and a projection extending from the container body;

means for capping a neck of the filled container body with a cap in the next operation of the production line;

means for transporting through the production line the container having the projection extending from the container body;

means for supporting, during the transporting, the container body having the projection extending from the container body;

means for cooling the container body filled with the hot product; and

means for pushing the projection extending from the cooled container body into the interior of the container body so that the resultant, filled and cooled container body is relatively free of structural geometry over a substantial portion of the surface.

2. The system for processing a plastic container according to claim 1, wherein when the container body is cooled by said means for cooling, the cooling produces a vacuum within the container body, and substantially all of the vacuum is taken up by the pushing.

3. The system for processing a plastic container according to claim 1, further comprising means for blow-molding a parison to form the container body, where the surface of the container body has the neck, a shoulder area, a base, and a smooth side surface surrounding the interior of the container body, and the projection extends from the base of the container body before the filling begins.

4. The system for processing a plastic container according to claim 3, further comprising:

means for inverting the projection extending from the container body into the interior of the container body in the next operation of the production line after the parison is blow-molded; and

means for repositioning the projection of the container body with a force prior to the filling by said means for filling so that the projection moves outside of the container body and extends from the container body.

5. The system for processing a plastic container according to claim 1, wherein the container body with the projection extending from the container is conveyed by its neck during the filling and capping.

6. The system for processing a plastic container according to claim 1, wherein the means for pushing the projection extending from the cooled container body into the interior of the container body is configured to position an actuator panel with projections extending therefrom underneath a container holding device where the

projections of the actuator panel correspond with container body projections through a respective opening of the container holding device;

further comprising means for moving the actuator panel so that the actuator panel projections push against the container projections thereby forcing the container projections inside respective container bodies.

7. The system for processing a plastic container according to claim 1, wherein the container body has a grip portion in addition to the substantial portion of the surface that is relatively free of structural geometry.

8. The system for processing a plastic container according to claim 2, further comprising at least a mini vacuum panel wherein the pushing of the projection takes up the majority of the resultant vacuum and the mini vacuum panel takes up the remainder.

1/14

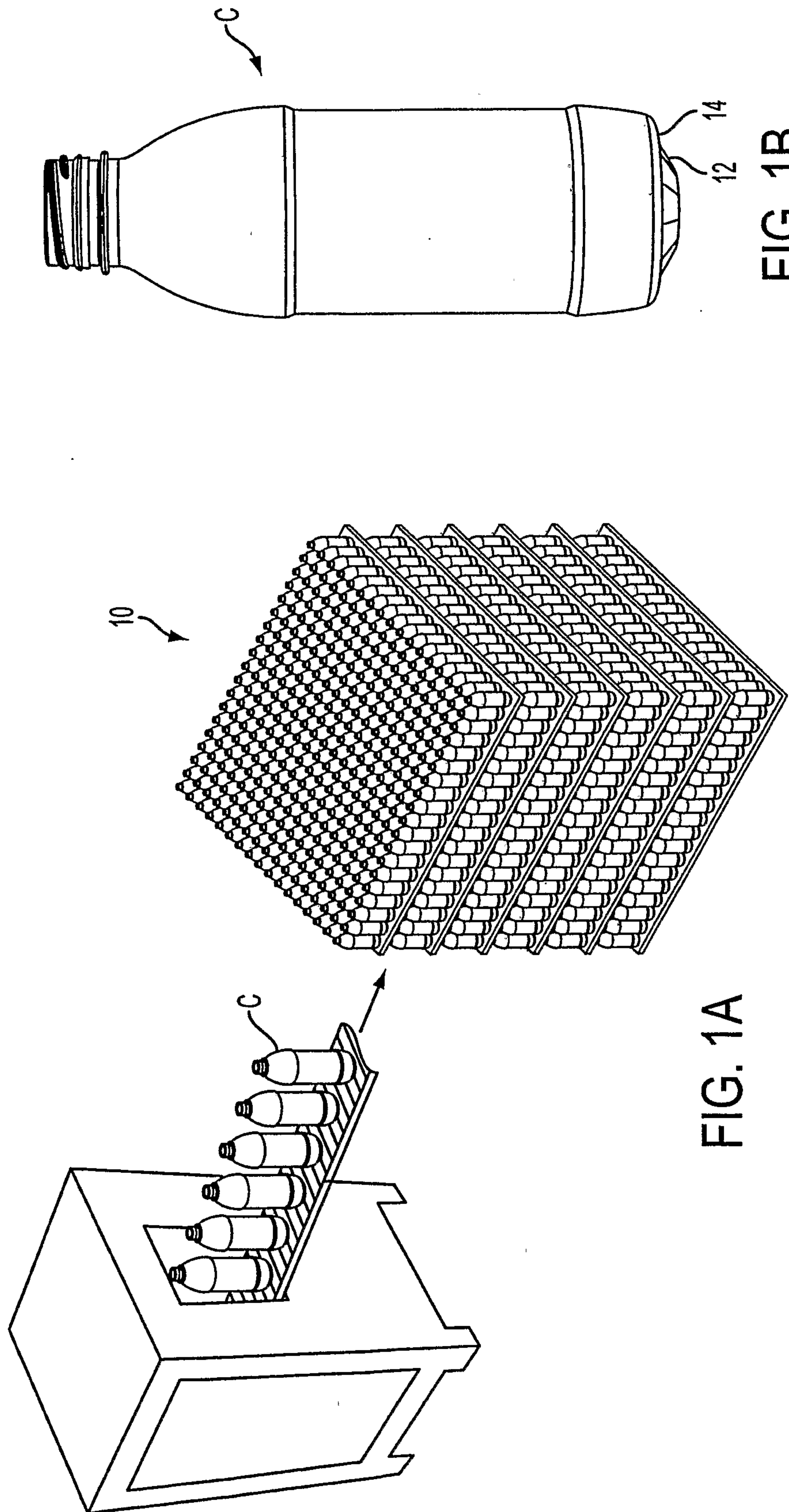

FIG. 1B

FIG. 1A

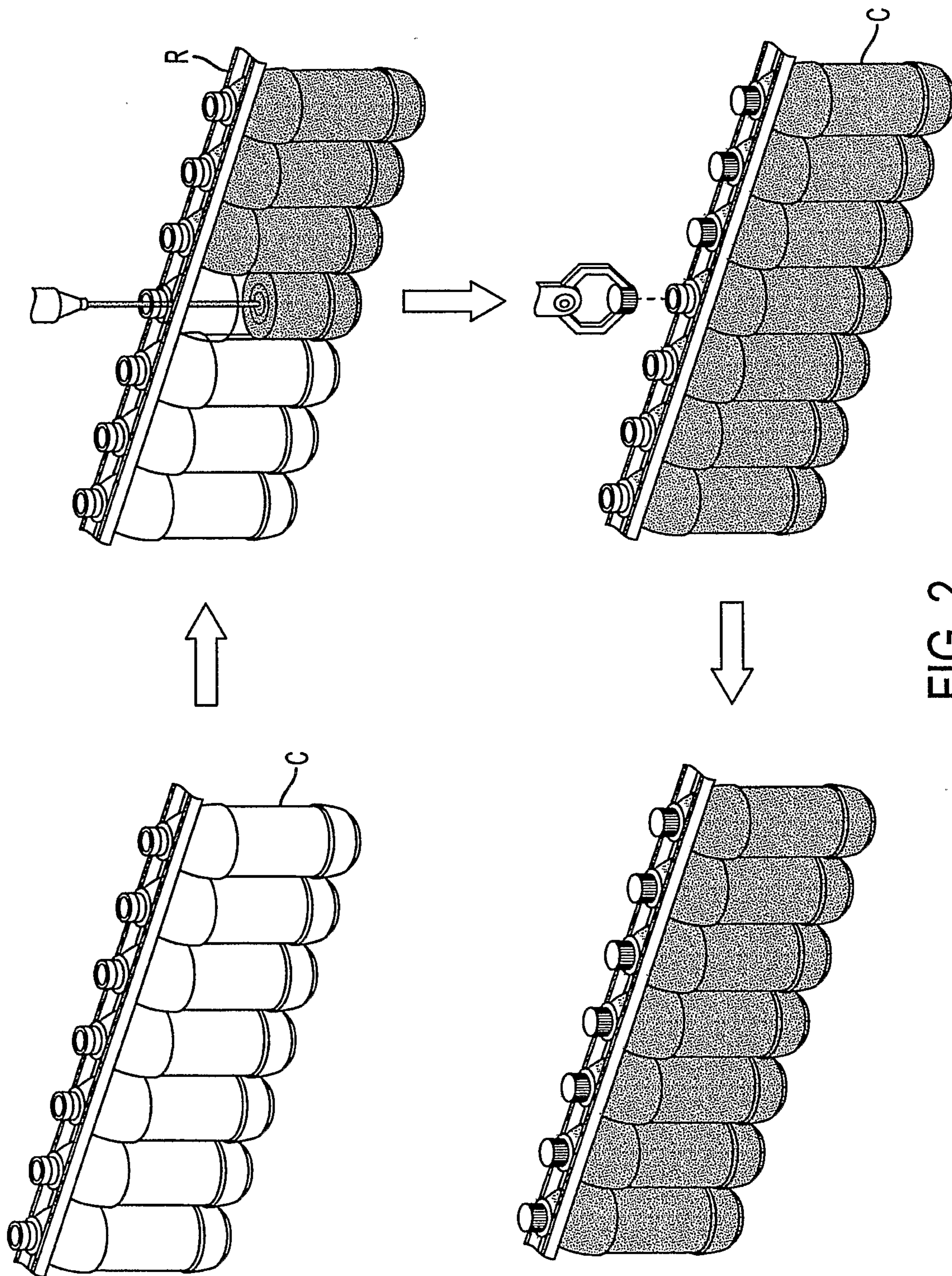

FIG. 2

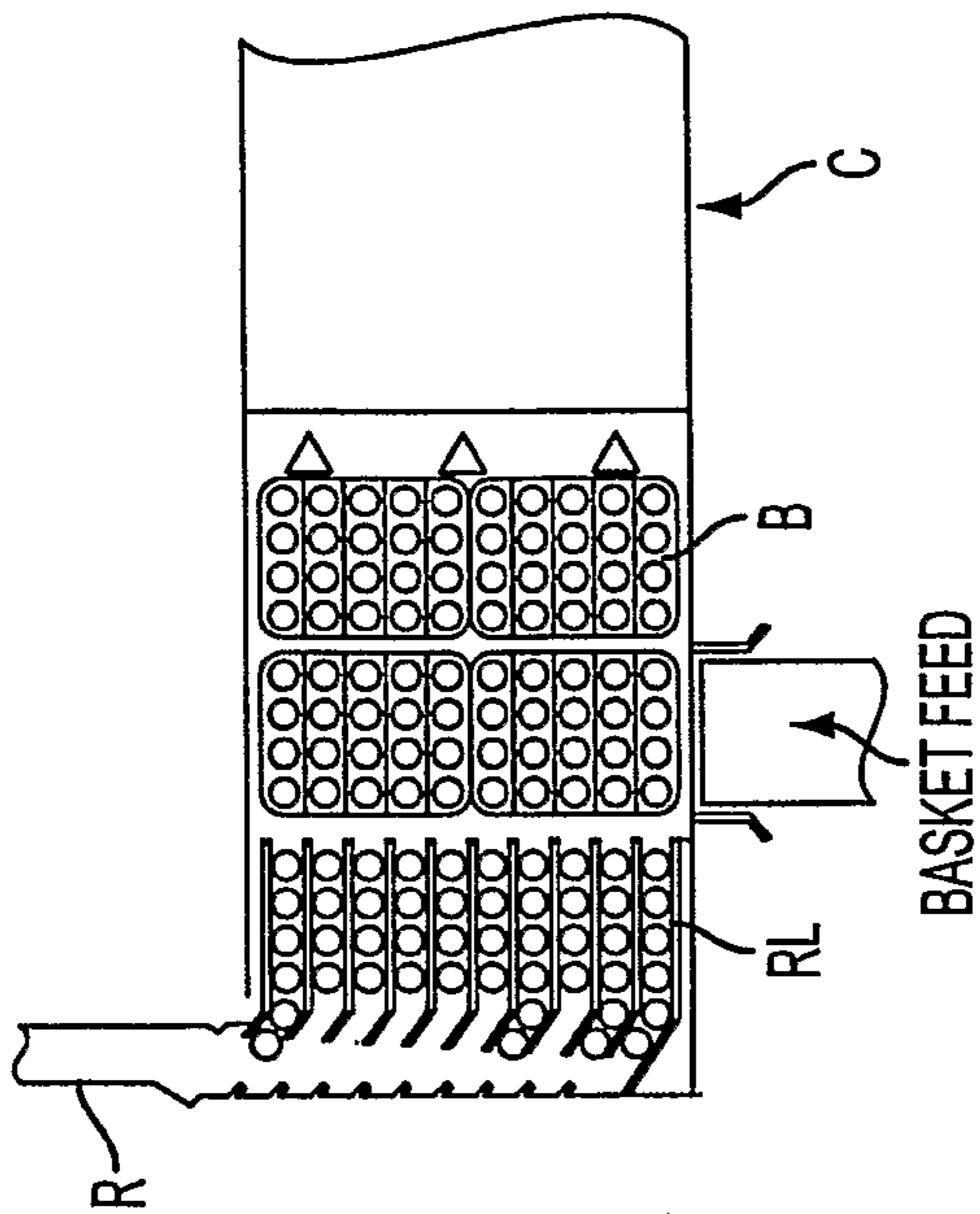

FIG. 3B

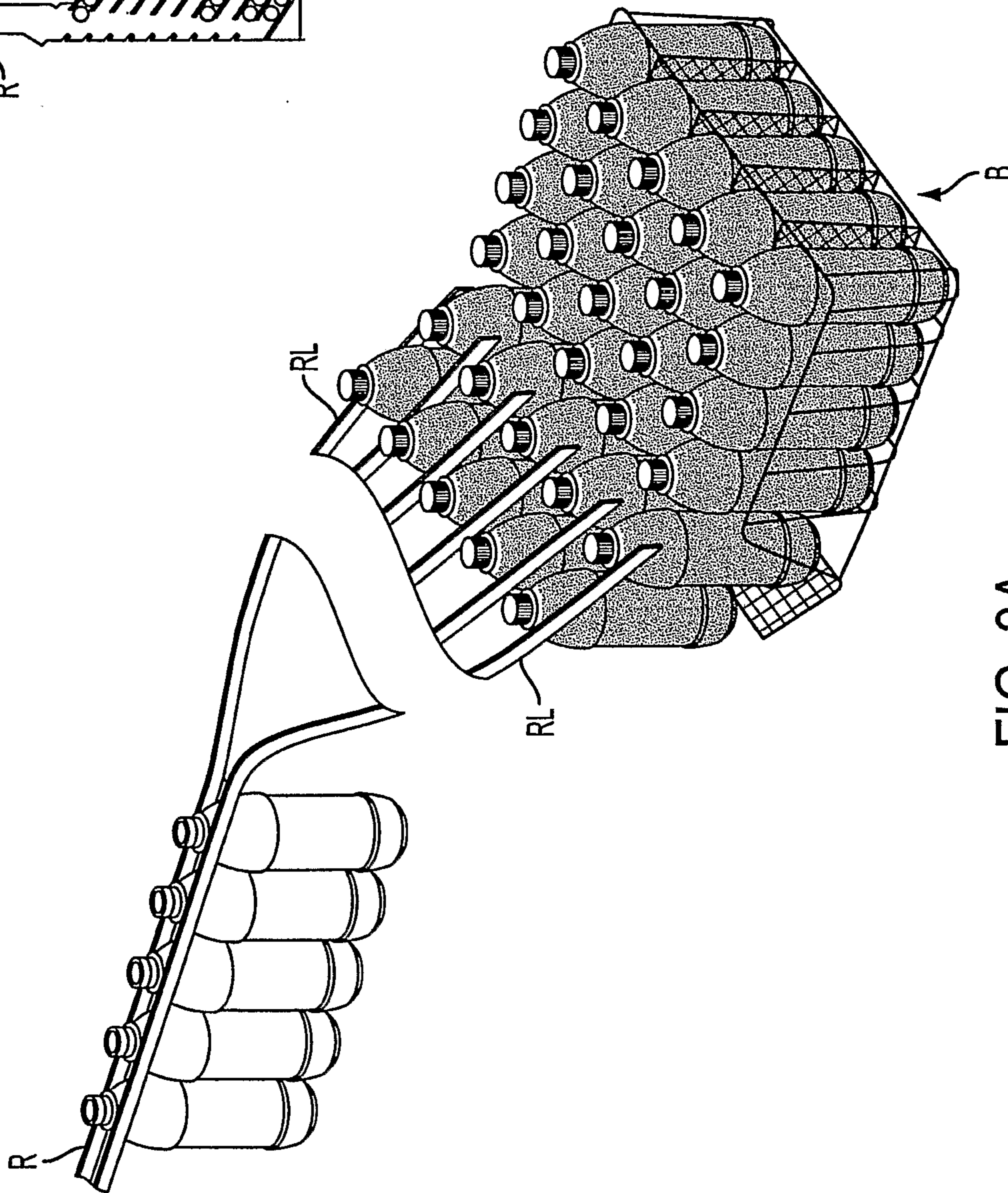

FIG. 3A

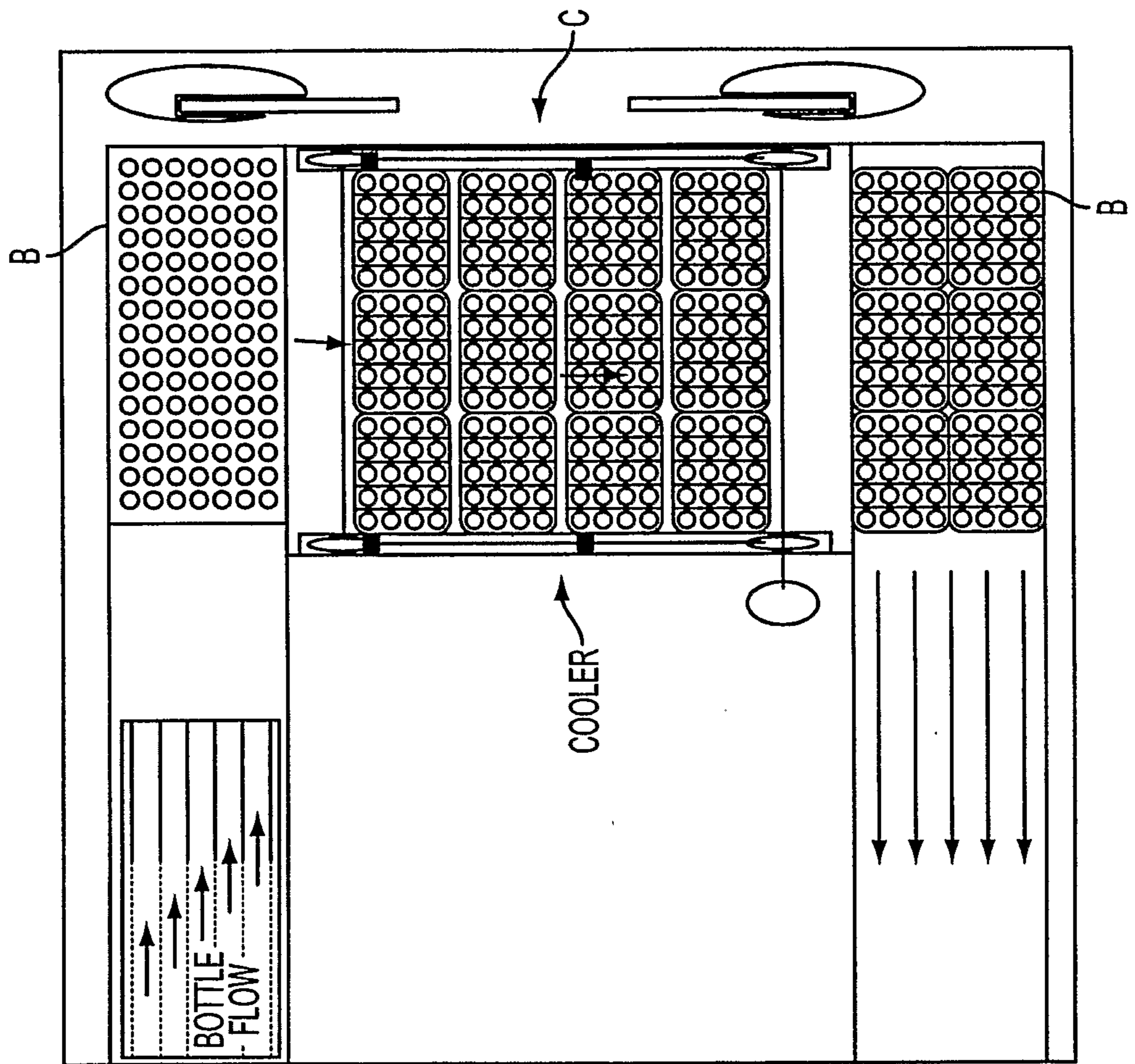

FIG. 4

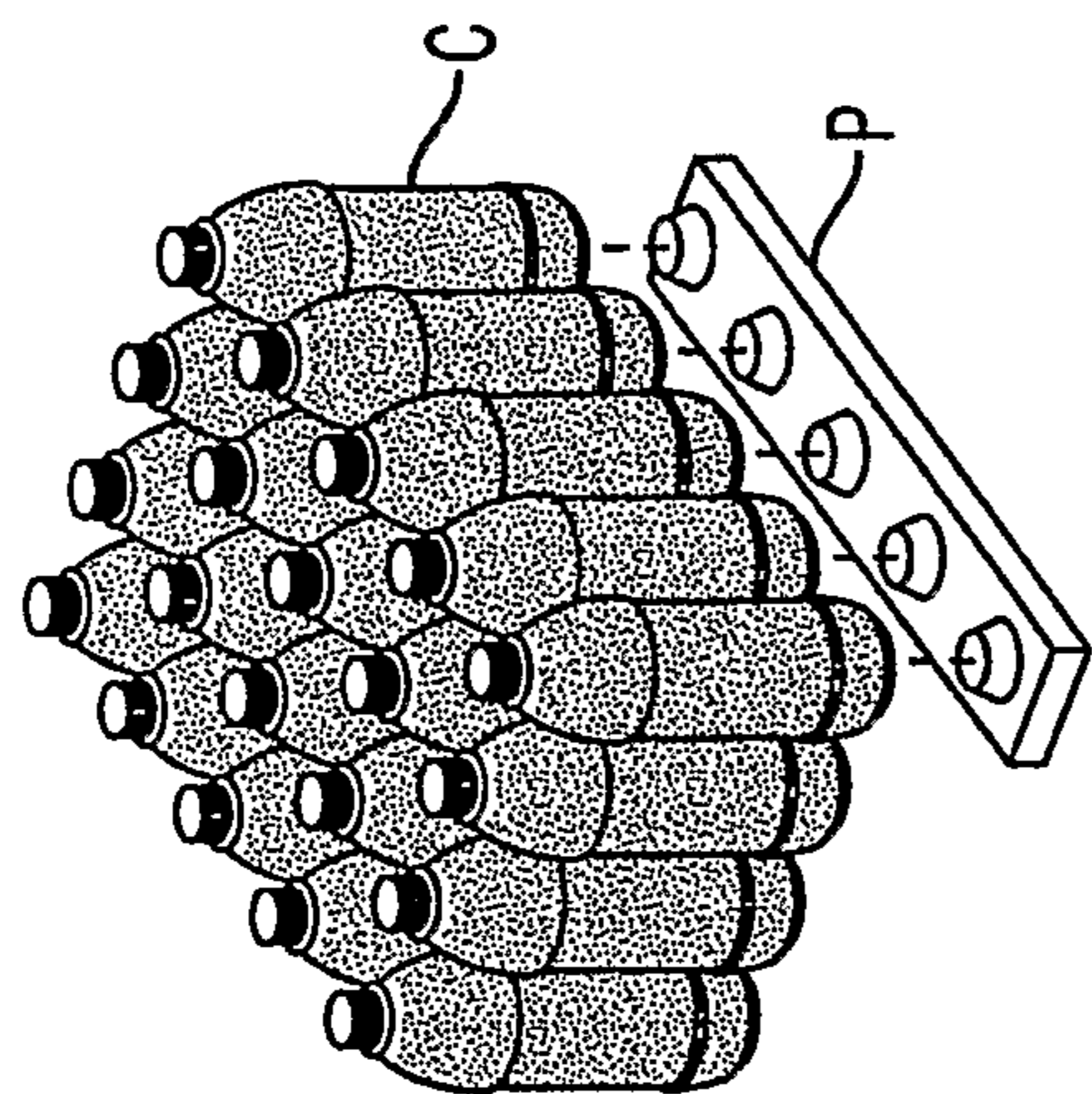

FIG. 5B

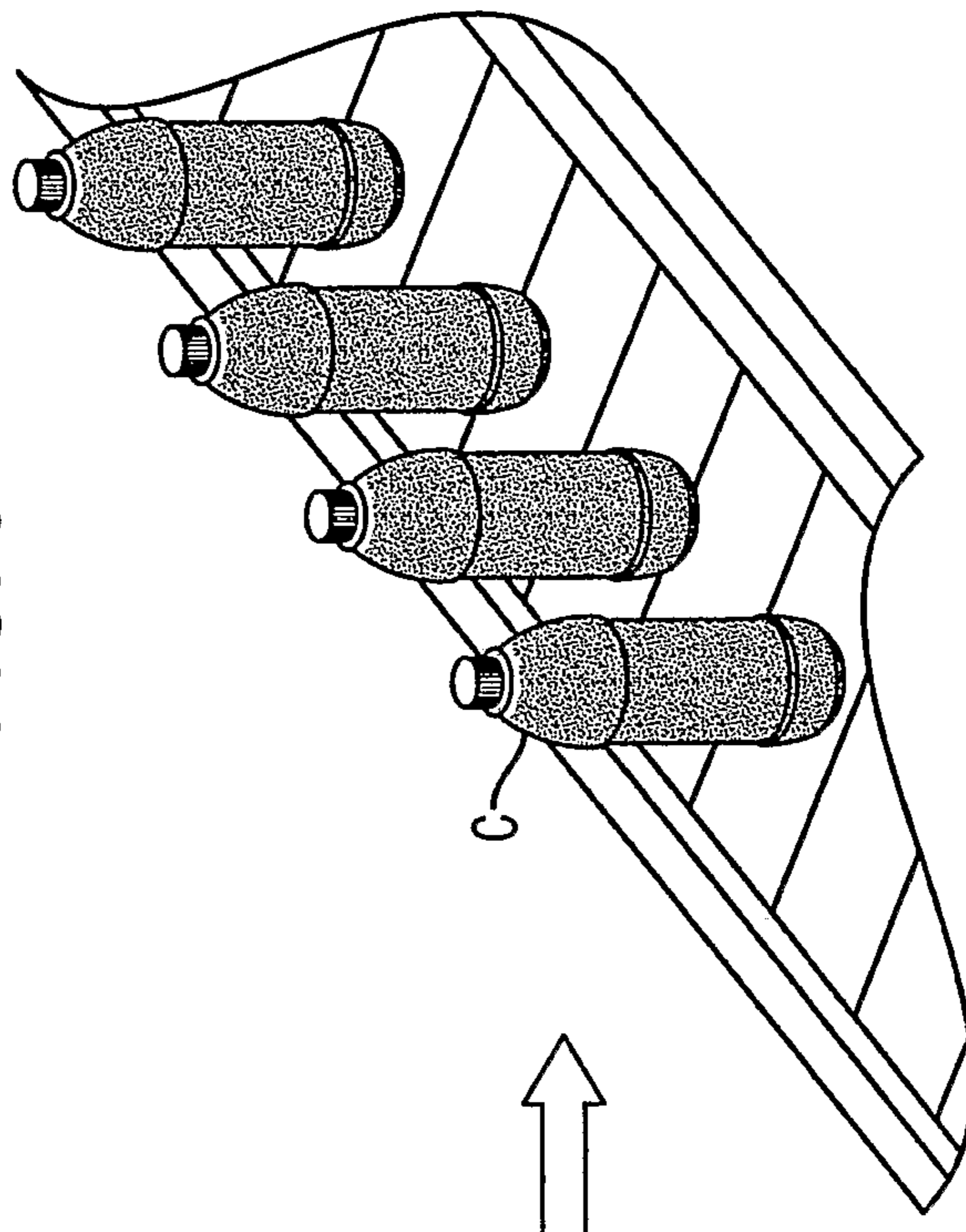

FIG. 5C

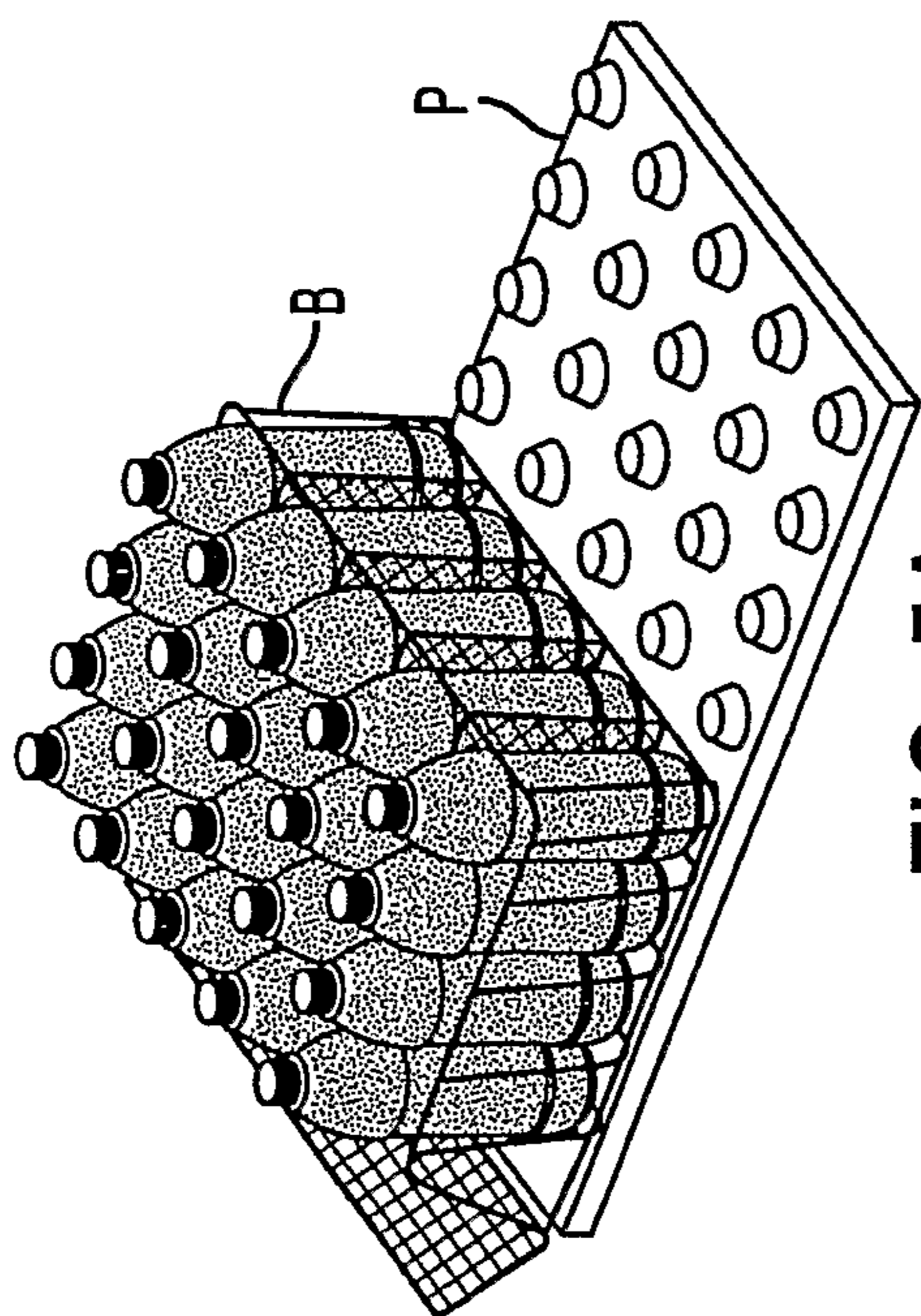

FIG. 5A

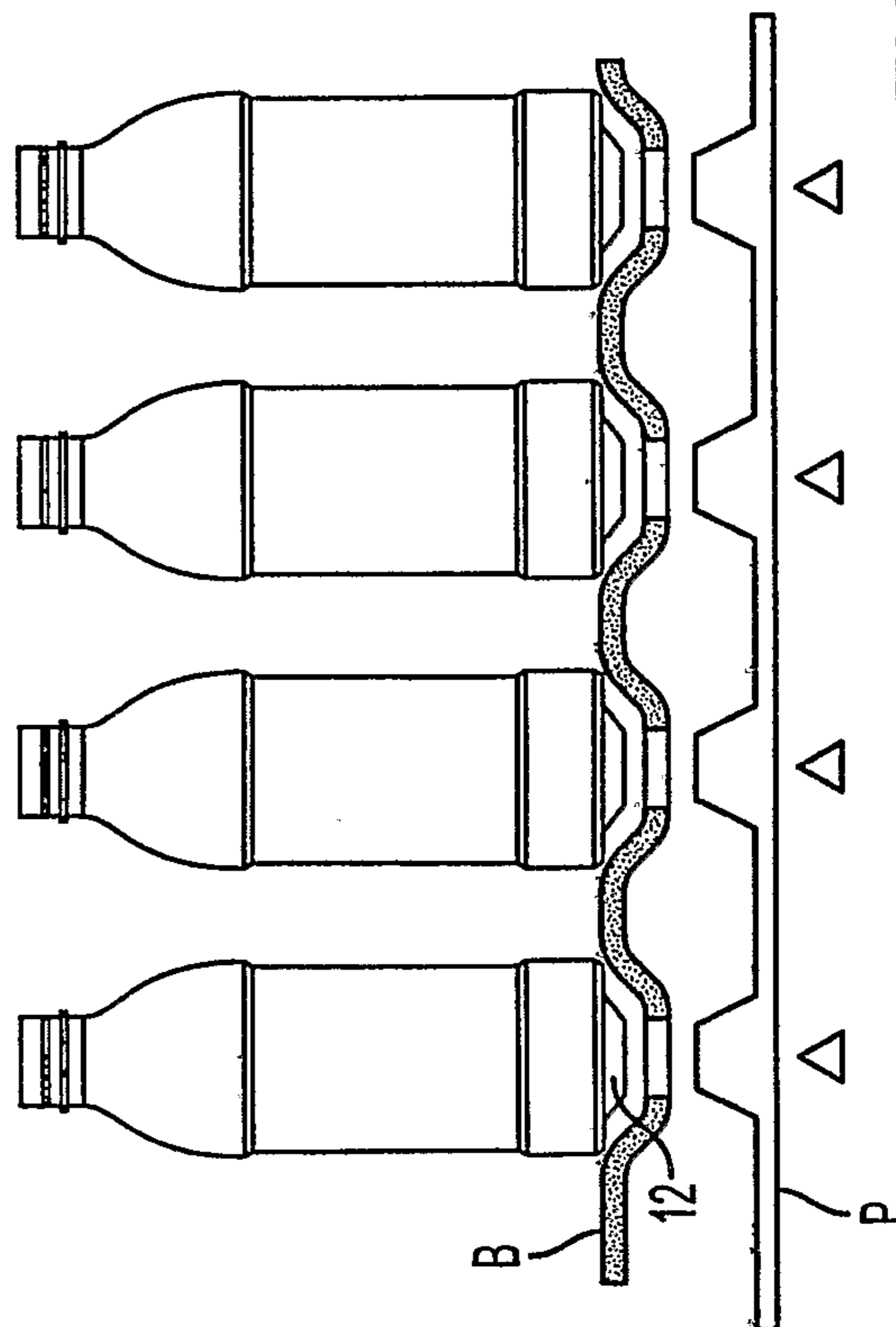

FIG. 5C

6/14

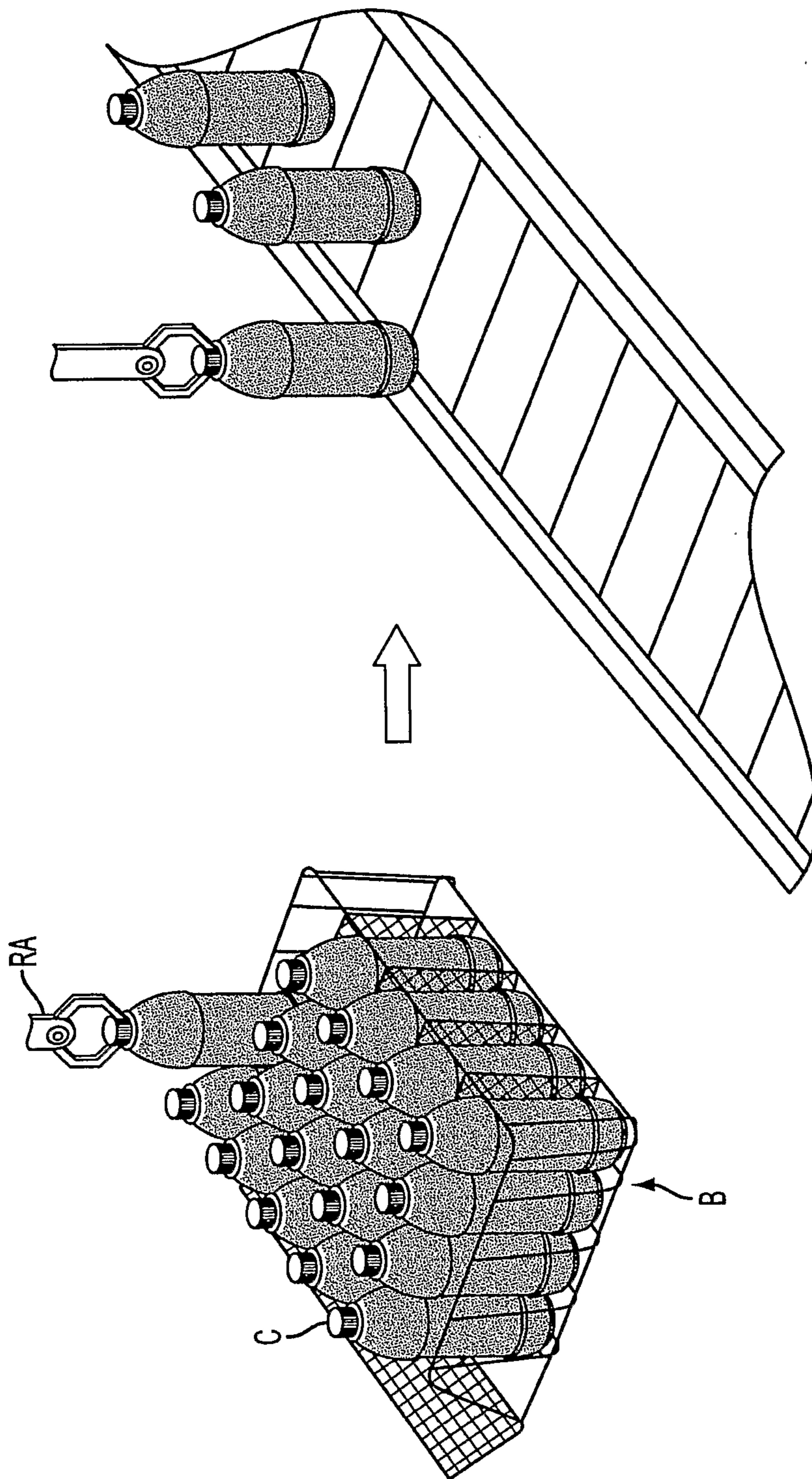

FIG. 6

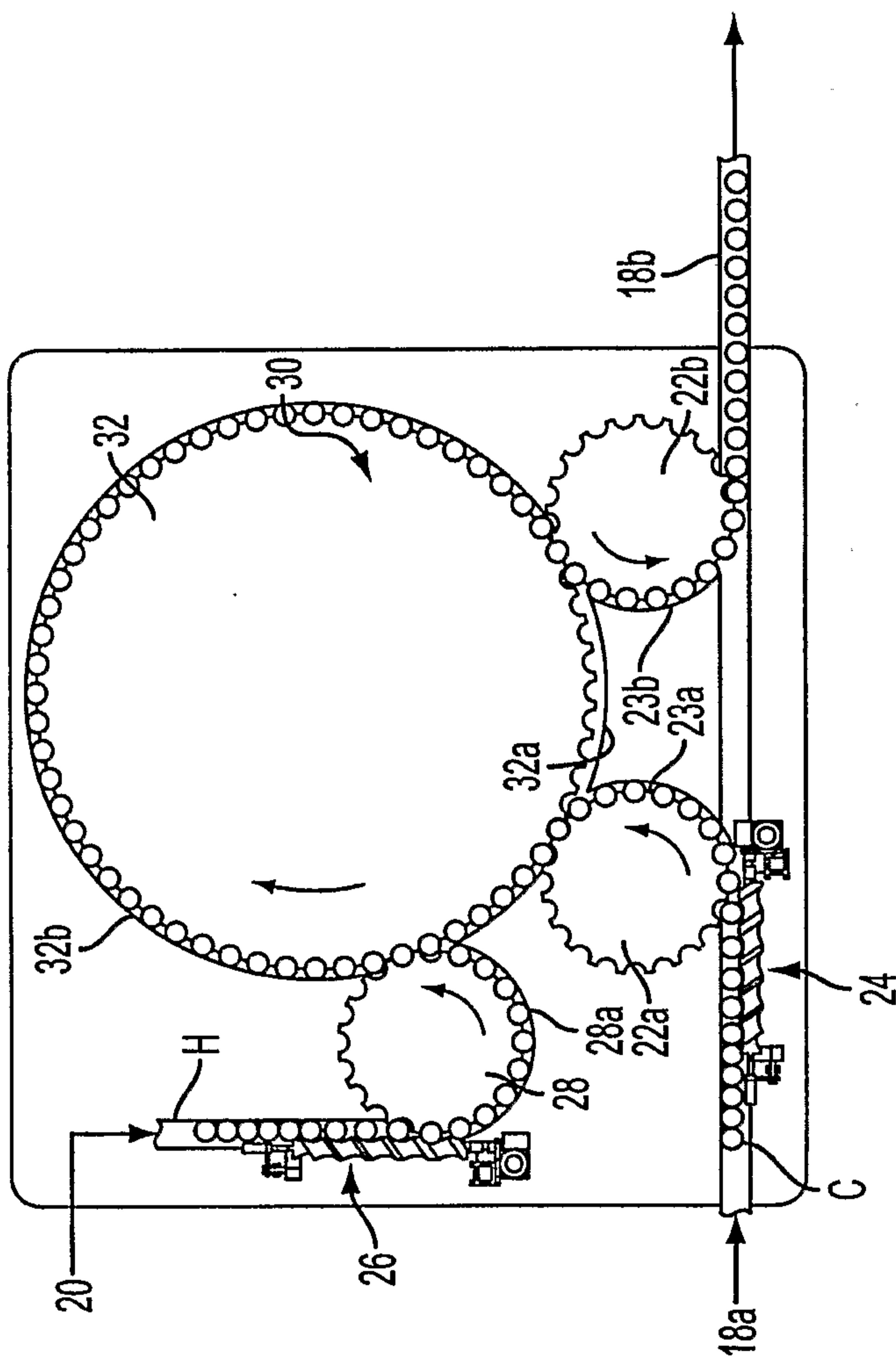

FIG. 7

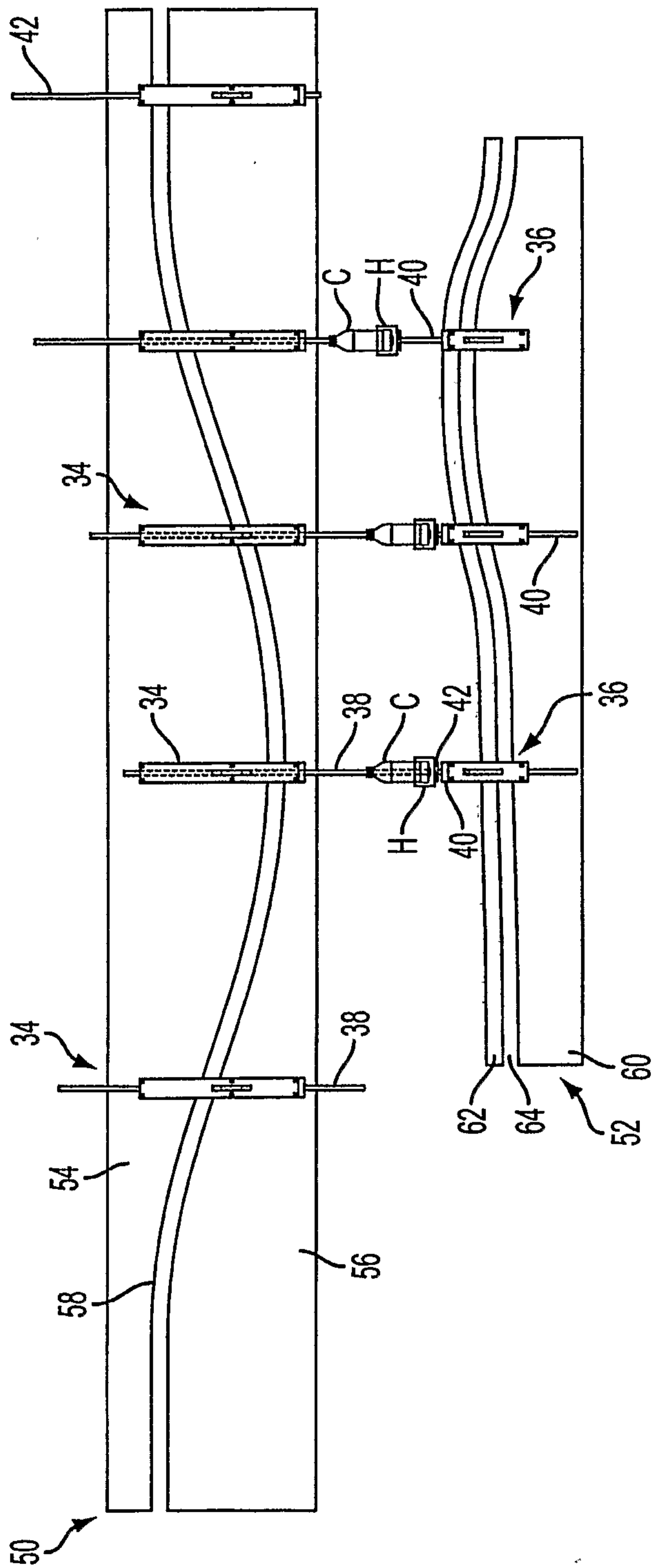

FIG. 9

10/14

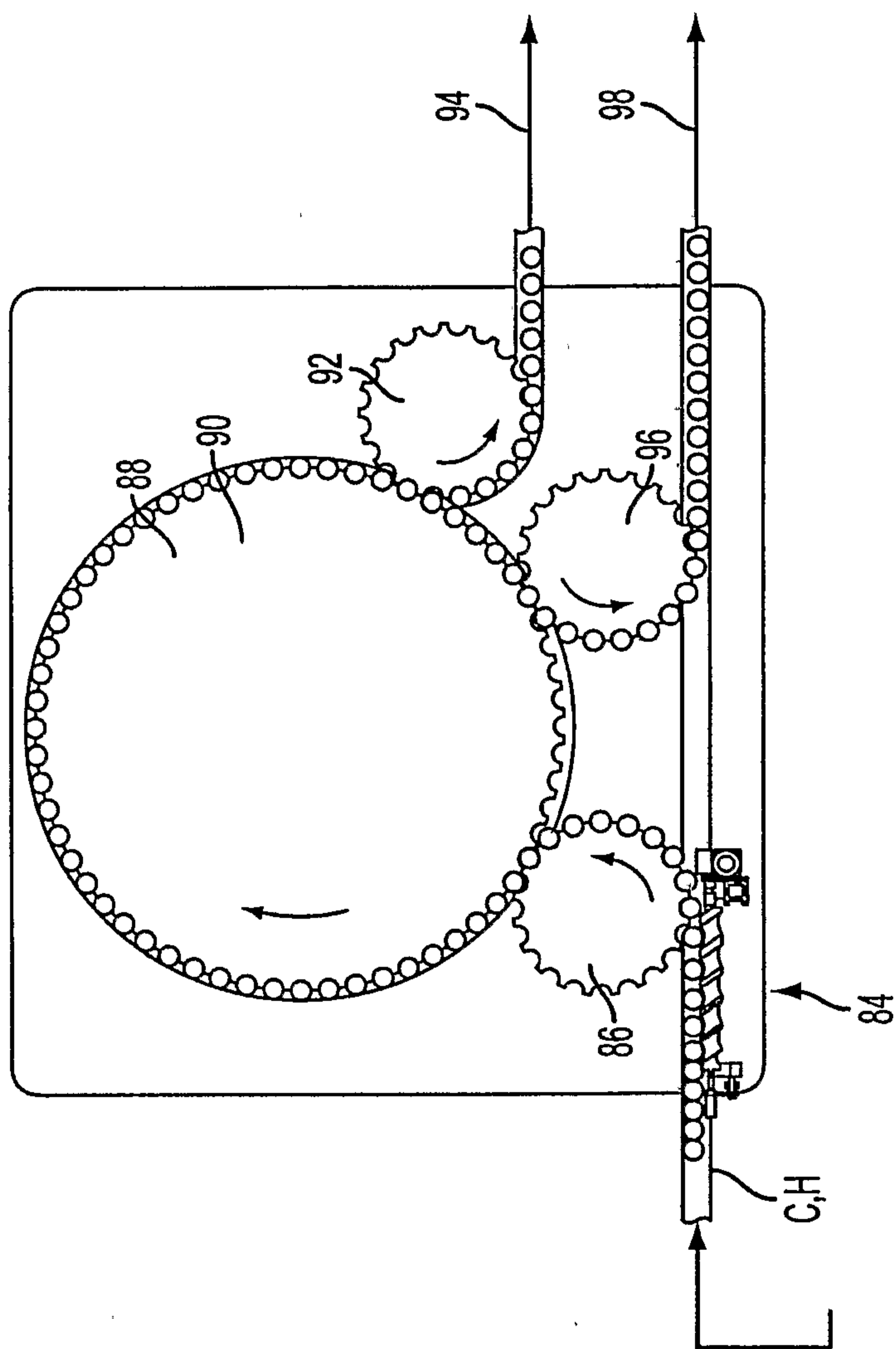

FIG. 10

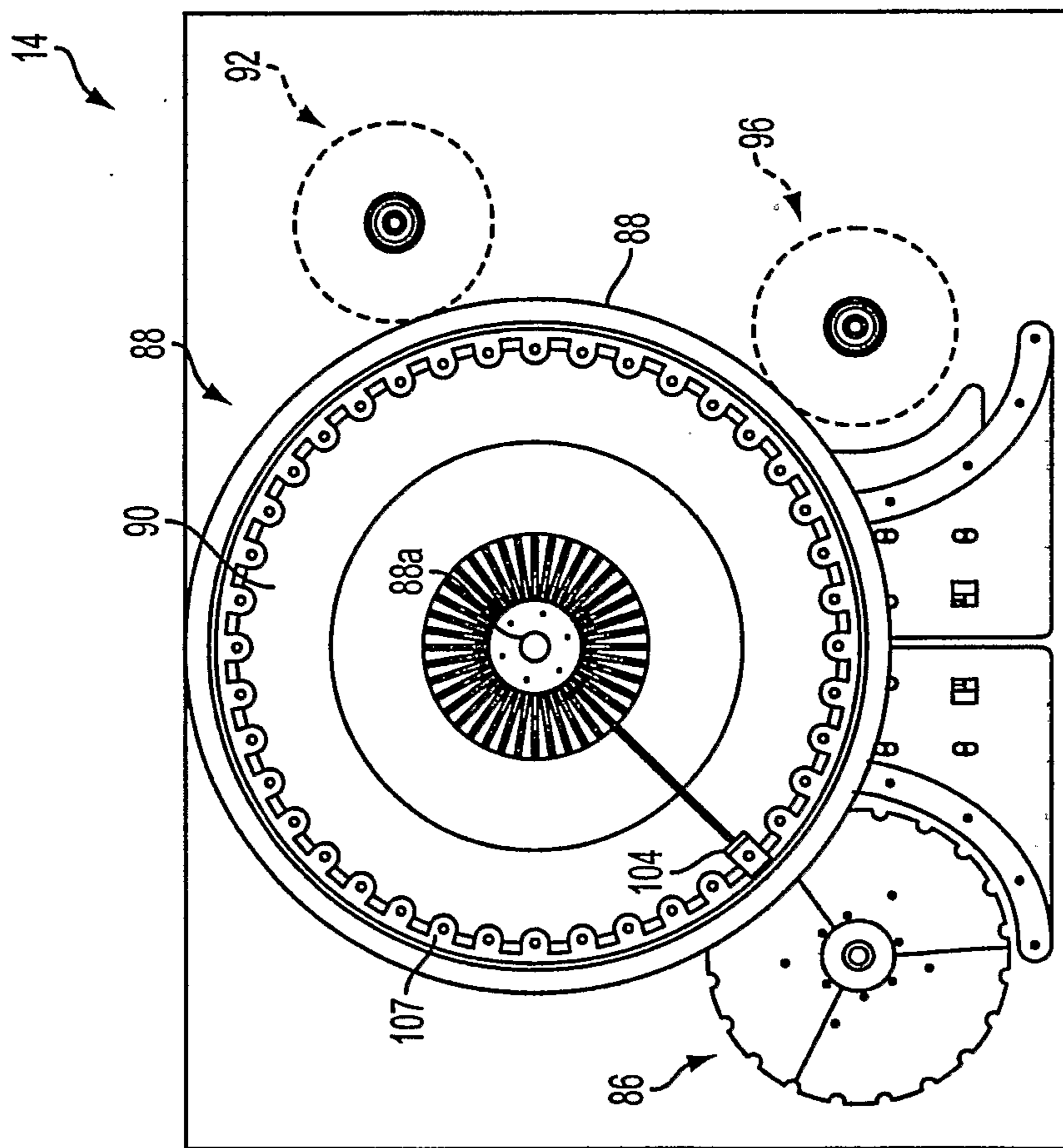

FIG. 11

12/14

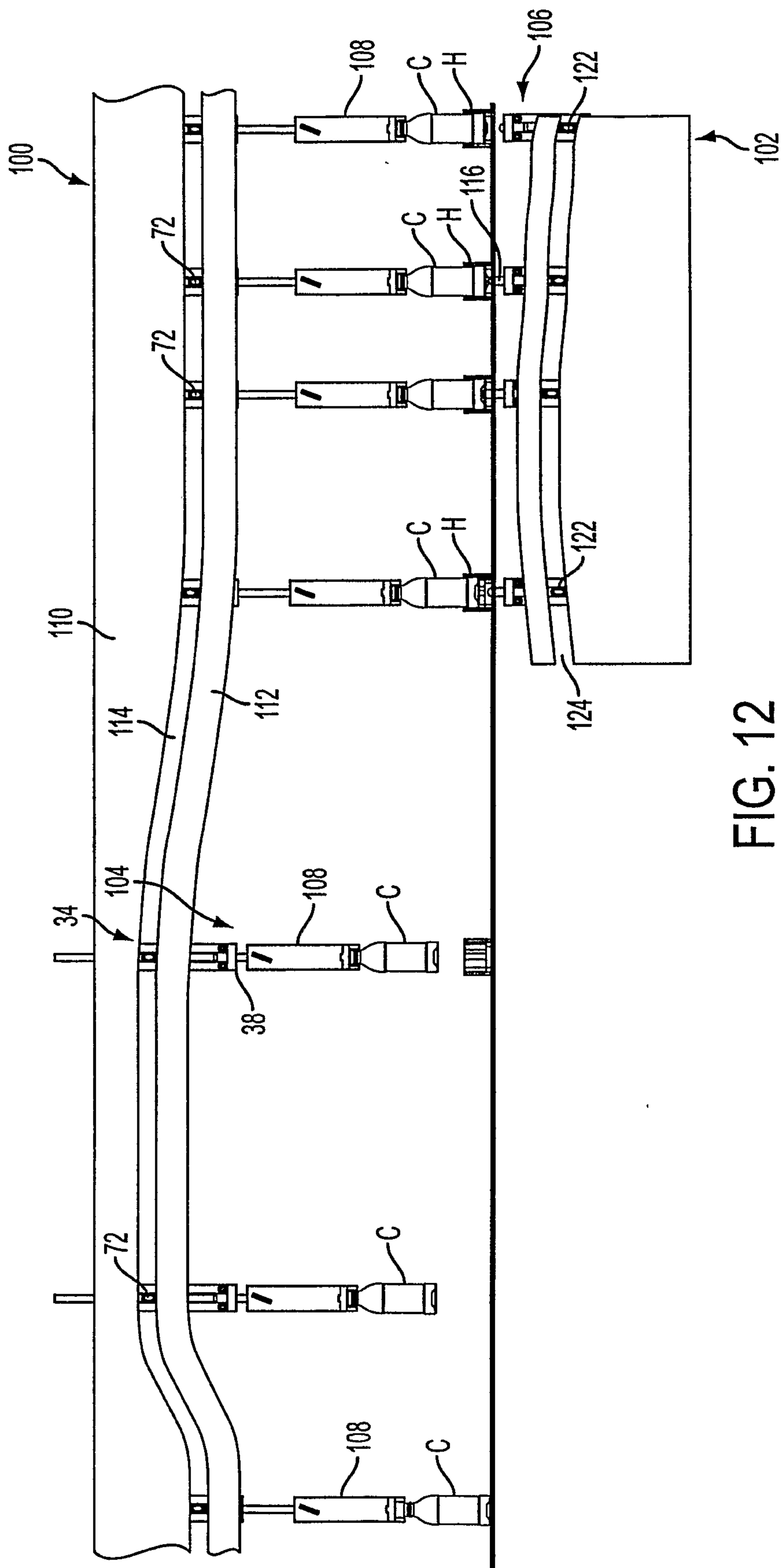

FIG. 12

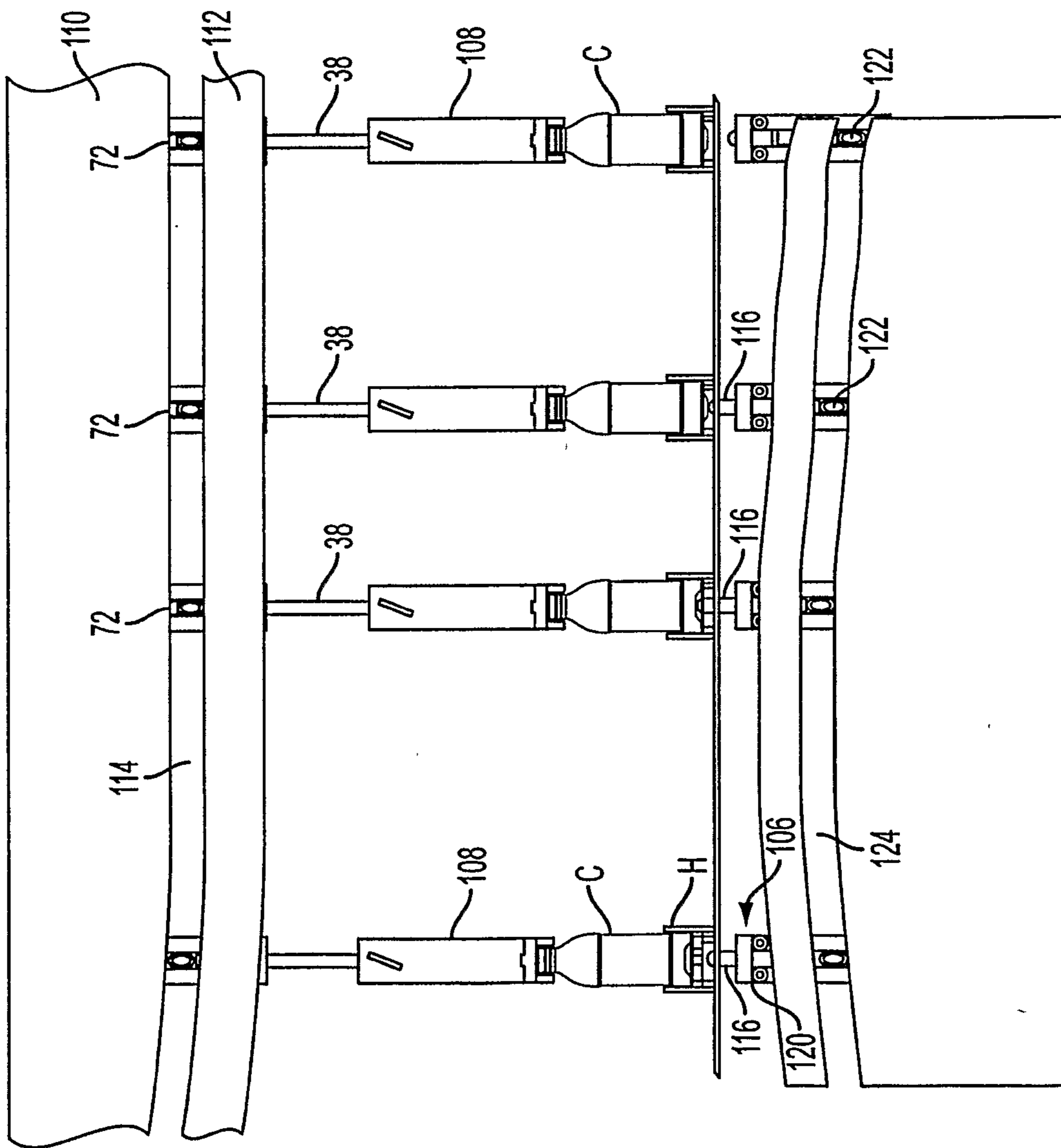

FIG. 13

14/14

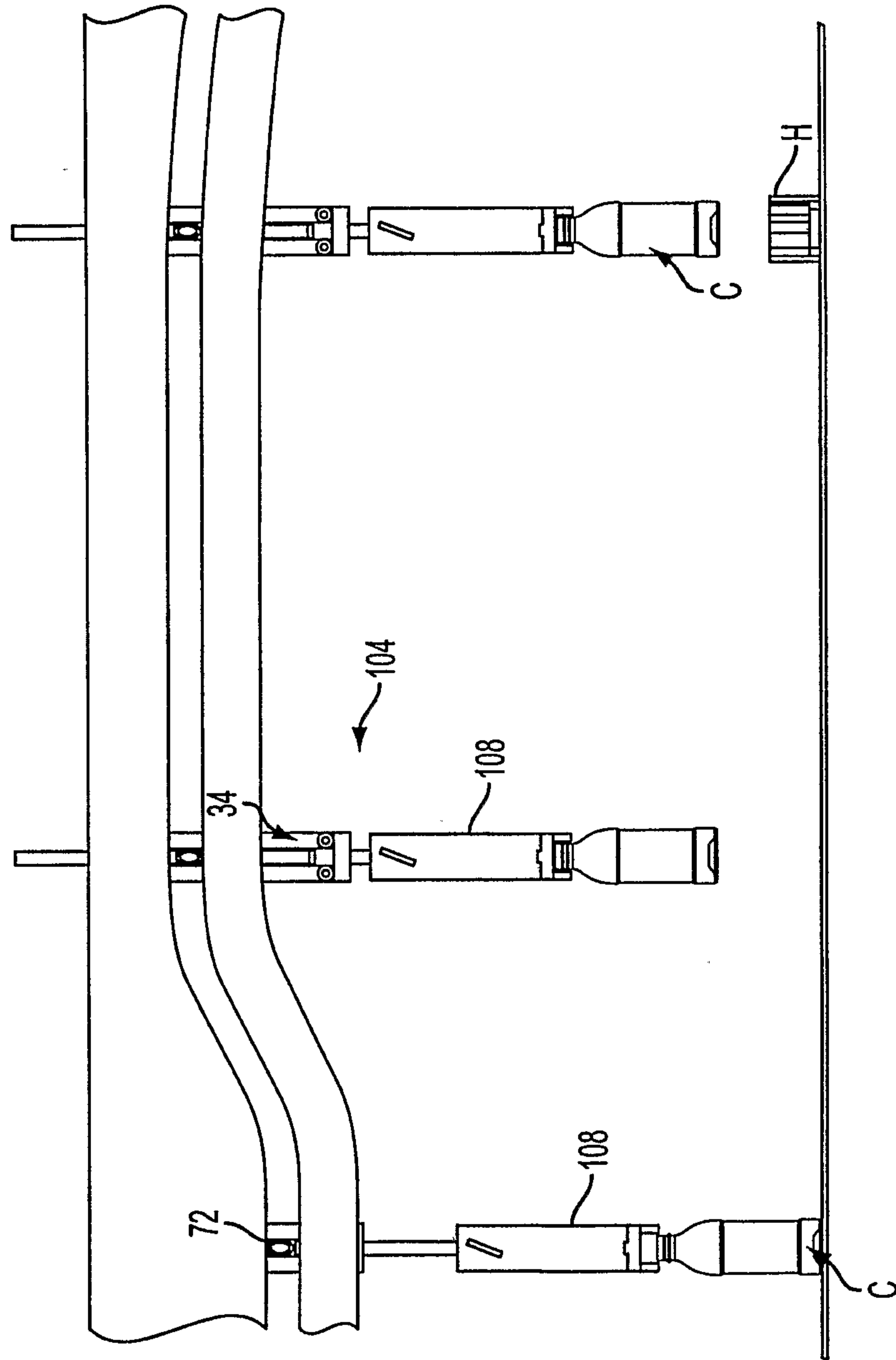

FIG. 14

