



(11) **EP 1 686 324 B1**

(12) **EUROPEAN PATENT SPECIFICATION**

(45) Date of publication and mention of the grant of the patent:  
**16.12.2009 Bulletin 2009/51**

(51) Int Cl.:  
**F24F 1/00<sup>(2006.01)</sup> F24F 13/20<sup>(2006.01)</sup>**

(21) Application number: **05258107.1**

(22) Date of filing: **29.12.2005**

(54) **Indoor unit of air-conditioning system**

Innenraumeinheit einer Klimaanlage

Unité d'intérieur d'un dispositif de conditionnement d'air

(84) Designated Contracting States:  
**DE FR GB IT NL TR**

(30) Priority: **29.12.2004 KR 2004115324**

(43) Date of publication of application:  
**02.08.2006 Bulletin 2006/31**

(73) Proprietor: **LG Electronics, Inc.**  
**Seoul (KR)**

(72) Inventor: **Kim, Kang Young**  
**Masan-si**  
**Gyeongsangnam-do (KR)**

(74) Representative: **Palmer, Jonathan R.**  
**Boulton Wade Tennant**  
**Verulam Gardens**  
**70 Gray's Inn Road**  
**London WC1X 8BT (GB)**

(56) References cited:  
**US-A1- 2002 104 329 US-A1- 2004 035 140**

- **PATENT ABSTRACTS OF JAPAN vol. 2003, no. 09, 3 September 2003 (2003-09-03) -& JP 2003 156226 A (LG ELECTRONICS INC), 30 May 2003 (2003-05-30)**
- **PATENT ABSTRACTS OF JAPAN vol. 2003, no. 12, 5 December 2003 (2003-12-05) -& JP 2003 343871 A (DAIKIN IND LTD), 3 December 2003 (2003-12-03)**

**EP 1 686 324 B1**

Note: Within nine months of the publication of the mention of the grant of the European patent in the European Patent Bulletin, any person may give notice to the European Patent Office of opposition to that patent, in accordance with the Implementing Regulations. Notice of opposition shall not be deemed to have been filed until the opposition fee has been paid. (Art. 99(1) European Patent Convention).

**Description****BACKGROUND OF THE INVENTION****Field of the Invention**

[0001] The present invention relates to a separate air-conditioning system, and more particularly, to an indoor unit of an air-conditioning system that is provided in a room to cool and heat the indoor air.

**Discussion of the Related Art**

[0002] Generally, an air-conditioning system is equipped with a compressor and a heat exchanger to cool or heat indoor places such as living places, restaurants, libraries, or offices by flowing a refrigerant therein. The air-conditioning system is generally divided into a separate air-conditioning system and an integral air-conditioning system.

[0003] The integral air-conditioning system includes an outdoor unit and an indoor unit formed in a single body without being separated from each other. The outdoor unit and the indoor unit are directly provided in a house in a state that they are built in a wall or hung on a window.

[0004] The separate air-conditioning system includes an indoor unit provided with a heat exchanger that carries out room cooling or room heating, an outdoor unit provided with a heat exchanger that performs heat exchange with the outdoor air, and a refrigerant pipe that connects the indoor unit with the outdoor unit.

[0005] In the separate air-conditioning system, the indoor unit and the outdoor unit are separately provided so that the indoor unit is provided at the indoor and the outdoor unit is provided at the outdoor.

[0006] To efficiently cool or heat an indoor place depending on shapes or sizes of the indoor place provided with the separate air-conditioning system or the integral air-conditioning system, the position and a shape of air outlets act as main factors.

[0007] Therefore, it is required to develop an indoor unit of an air-conditioning system that uniformly supplies the air into each portion of the indoor place.

[0008] Document JP 2003 156 226 discloses an air conditioner having inlet ports and outlet ports in a cabinet so that an air state is changed and air can be delivered into the room after sucking the air in the room.

[0009] Document JP 2003 343871 discloses a floor type air conditioner set on an indoor floor comprising a heat exchanger, a blowoff part and a fan, the blowout part having a plurality of blowoff ports arranged in a lateral direction.

**SUMMARY OF THE INVENTION**

[0010] There is provided an indoor unit of an air conditioning system as set out in claim 1.

[0011] Accordingly, the present invention is directed

to an indoor unit of an air-conditioning system that substantially obviates one or more problems due to limitations and disadvantages of the related art.

[0012] An object of the present invention is to provide an indoor unit of an air-conditioning system that quickly and uniformly performs room cooling or room heating.

[0013] Additional advantages, objects, and features of the invention will be set forth in part in the description which follows and in part will become apparent to those having ordinary skill in the art upon examination of the following or may be learned from practice of the invention. The objectives and other advantages of the invention may be realized and attained by the structure particularly pointed out in the written description and claims hereof as well as the appended drawings.

[0014] These objects are achieved with the features of independent claim 1 and of dependent claims 2 to 19.

[0015] It is to be understood that both the foregoing general description and the following detailed description of the present invention are exemplary and explanatory and are intended to provide further explanation of the invention as claimed.

**BRIEF DESCRIPTION OF THE DRAWINGS**

[0016] The accompanying drawings, which are included to provide a further understanding of the invention and are incorporated in and constitute a part of this application, illustrate embodiment(s) of the invention and together with the description serve to explain the principle of the invention. In the drawings:

FIG. 1 is a perspective view illustrating an indoor unit of an air-conditioning system according to the first embodiment of the present invention;

FIG. 2 is a front view illustrating the indoor unit of FIG. 1;

FIG. 3 is a front view illustrating the state that the indoor unit of FIG. 1 stops;

FIG. 4 is an exploded perspective view illustrating the indoor unit of the air-conditioning system according to the first embodiment of the present invention;

FIG. 5 is a sectional view illustrating the indoor unit of the air-conditioning system according to the first embodiment of the present invention;

FIG. 6 is an exploded perspective view illustrating a door driving gear of the indoor unit of the air-conditioning system according to the first embodiment of the present invention;

FIG. 7 is a perspective view illustrating the state that left and right outlet doors are opened by the door driving gear of FIG. 6;

FIG. 8 is a perspective view illustrating the state that the left and right outlet doors are closed by the door driving gear of FIG. 6;

FIG. 9 is a perspective view illustrating an indoor unit of an air-conditioning system according to the second embodiment of the present invention;

FIG. 10 is a front view illustrating the indoor unit of FIG. 9;

FIG. 11 is a perspective view illustrating an indoor unit of an air-conditioning system according to the third embodiment of the present invention;

FIG. 12 is a front view illustrating the indoor unit of FIG. 11;

FIG. 13 is a perspective view illustrating an indoor unit of an air-conditioning system according to the fourth embodiment of the present invention; and

FIG. 14 is a front view illustrating the indoor unit of FIG. 13.

### DETAILED DESCRIPTION OF THE INVENTION

**[0017]** Reference will now be made in detail to the preferred embodiments of the present invention, examples of which are illustrated in the accompanying drawings. Wherever possible, the same reference numbers will be used throughout the drawings to refer to the same or like parts.

**[0018]** Referring to FIG. 1 to FIG. 3, an indoor unit of an air-conditioning system according to the first embodiment of the present invention includes a cabinet 100 provided with various elements of the indoor unit.

**[0019]** Air outlets 101 and 102 are formed at one side and the other side of the cabinet 100 to discharge the air. The air outlets 101 and 102 are opened and closed by outlet doors 210 and 220 that are movably provided in the cabinet 100.

**[0020]** In more detail, the outlet doors 210 and 220 are preferably formed at left and right side portions of the cabinet 100.

**[0021]** Hereinafter, for convenience of description, the air outlet formed at the left side portion of the cabinet 100 is referred to as the left air outlet 101, and the air outlet formed at the right side portion of the cabinet 100 is referred to as the right air outlet 102.

**[0022]** The outlet door that opens and closes the left air outlet 101 is referred to as the left outlet door 210, and the outlet door that opens and closes the right air outlet 102 is referred to as the right outlet door 220.

**[0023]** The left and right air outlets 101 and 102 are formed at both edge portions of the front surface of the cabinet 100 so that they are to be flush with the front surface of the cabinet 100. Alternatively, the left and right air outlets 101 and 102 may be formed at both side portions of the front surface of the cabinet 100.

**[0024]** Further, the left and right air outlets 101 and 102 are preferably formed above the left and right side portions of the cabinet 100. More specifically, the left and right air outlets 101 and 102 are longitudinally formed above the left and right side portions of the cabinet 100 in up and down directions.

**[0025]** In addition, an upper air outlet 103 is preferably formed at an upper side of the cabinet 100.

Meanwhile, at least one air inlet is preferably formed at a lower portion of the cabinet 100, so that the indoor air

is sucked to the air inlet.

**[0026]** In the first embodiment of the present invention, a left air inlet 105 and a right air inlet 106 are longitudinally formed below the left and right side portions of the cabinet 100 in a vertical direction.

**[0027]** A front air inlet 104 is formed at a lower end of the front surface of the cabinet 100.

**[0028]** However, it is noted that the number of the air inlets and their positions are not limited to above cases.

**[0029]** The front air inlet 104, the left air inlet 105, and the right air inlet 106 are formed at the lower portion of the cabinet 100.

**[0030]** Next, the indoor unit of the air-conditioning system will be described in more detail with reference to FIG. 4 and FIG. 5.

**[0031]** Referring to FIG. 4 and FIG. 5, a heat exchanger 300 and a blower 400 are received in the cabinet 100. The heat exchanger 300 serves to cool and heat the air while the blower 400 serves to forcibly flow the air.

**[0032]** The blower 400 is provided at a lower portion inside the cabinet 100 and the heat exchanger 300 is slantingly provided above the blower 400 to perform heat exchange with the air discharged from the blower 400.

**[0033]** The cabinet 100 includes a front cabinet 110, a rear cabinet 120, and a base 130. The base 130 supports lower portions of the front and rear cabinets 110 and 120.

**[0034]** The front cabinet 110 is fixed to the front end of the rear cabinet 120 to form a space that receives the blower 400 and the heat exchanger 300.

**[0035]** The front cabinet 110 has a rear side and a bottom that are opened. The front cabinet 110 includes a front surface, left side portions 111 and 112, and right side portions 113 and 114. The left and right side portions are provided at both sides of the front surface.

**[0036]** Thus, the cabinet 100 provided with the left and right air outlets 101 and 102 include the left and right side portions 111 to 114.

**[0037]** The left and right side portions of the front cabinet 110 may be extended toward the rear in a vertical direction from the front surface of the front cabinet 110. However, it is preferable that the left and right side portions of the front cabinet 110 include a left slant surface 111a and a right slant surface 113a that are spaced apart from each other toward the rear at a predetermined angle from the front surface of the front cabinet 110.

**[0038]** A slant angle between the front surface of the front cabinet 110 and the left slant surface 111a and a slant angle between the front surface of the front cabinet 110 and the right slant surface 113a are preferably within the range of 15° to 25°, more specifically, 20°. However, the slant angles are not limited to the above range.

**[0039]** The left slant surface 111a and the right slant surface 113a may be replaced with a left plane portion (not shown) and a right plane portion (not shown) that are substantially flush with the front surface of the front cabinet. The left air outlet 101 and the right air outlet 102 may respectively be formed at the left plane portion and the right plane portion.

**[0040]** In addition, the front cabinet further include left and right side portions 112 and 114 extended from the rear ends of the left and right slant surfaces 111a and 113a to their rear directions at a predetermined angle from the left and right slant surfaces 111a and 113a.

**[0041]** The left and right side portions 112 and 114 may be substantially vertical to the front surface of the front cabinet 110.

**[0042]** The upper half of the front cabinet 110 provided with the air outlets 101, 102 and 103 and the lower half of the front cabinet 110 provided with the left and right air inlets 105 and 106 may separately provided to be detached from each other.

**[0043]** Preferably, the lower front surface of the front cabinet 110 may be opened to easily repair or clean various elements received in the cabinet 100.

**[0044]** In this embodiment, the left lower half provided with the left air inlet 105 is made of a left lower panel separately provided. The right lower half provided with the right air inlet 106 is also made of a right lower panel separately provided.

**[0045]** Therefore, if the left lower panel and the right lower panel are fixed to the upper half of the front cabinet, an opening is formed between the left lower panel and the right lower panel.

**[0046]** Meanwhile, the left air outlet 101 and the right air outlet 102 are respectively formed at the left side portions 111 and 112 and the right side portions 113 and 114 corresponding to the upper half of the front cabinet.

**[0047]** More specifically, the left and right air outlets 101 and 102 are respectively formed at the left slant surface 111a and the right slant surface 113a of the upper half of the front cabinet 110.

**[0048]** The left air inlet 105 and the right air inlet 106 are respectively formed at both sides 112b and 114b of the lower half of the front cabinet 110.

**[0049]** However, the left air outlet 101 and the right air outlet 102 may respectively be formed at both sides 112a and 114a of the upper half of the front cabinet 110. Alternatively, the left air outlet 101 and the right air outlet 102 may respectively be formed at a left slant surface 111b and a right slant surface 113b of the lower half of the front cabinet.

**[0050]** In addition, it is preferable that a wind controller that controls the wind of the discharged air is respectively provided at the left air outlet 101 and the right air outlet 102.

**[0051]** In this embodiment, a plate shaped left wind vane 141 is provided at the left air outlet 101 and a plate shaped right wind vane 142 is provided at the right air outlet 102.

**[0052]** Upper and lower ends of the left and right wind vanes 141 and 142 are rotatably connected with upper and lower ends of the left and right air outlets 101 and 102, and driving motors 141a and 142a are connected to any one of the upper and lower ends of the left and right wind vanes 141 and 142 to change the wind of the discharged air to left and right directions.

**[0053]** A door driving gear 600 is provided at the upper portion of the front surface of the front cabinet 110 to drive the left and right outlet doors 210 and 220.

**[0054]** The door driving gear is covered with a front cover 150 constituting the front surface of the upper half of the front cabinet 110, and a fitting plate 160 is provided at the rear of the front cover 150 to fit the door driving gear. The door driving gear will be described later in detail with reference to FIG. 6 to FIG. 8.

**[0055]** The upper air outlet 103 is formed at an upper side 115 substantially vertical to the front surface of the front cabinet 110.

**[0056]** The upper air outlet 103 is provided with an upper door 230 rotated by a separate driving motor 231. The upper door 230 opens and closes the upper air outlet 103 and at the same time controls the wind of the discharged air.

**[0057]** Next, left and right inlet vanes 143 and 144 are rotatably provided at the left and right air inlets 105 and 106, respectively. The left and right inlet vanes 143 and 144 open and close the left and right air inlets 105 and 106 and at the same time guide the sucked air.

**[0058]** Upper and lower ends of the left and right inlet vanes 143 and 144 are rotatably connected with upper and lower ends of the left and right air inlets 105 and 106, and separate driving motors 143a and 144a are connected to any one of the upper and lower ends of the left and right inlet vanes 143 and 144.

**[0059]** Further, filter setting portions 161 and 162 are provided inside the left and right air inlets 105 and 106 so that left and right air filters 161a and 162a are set therein. The air filters 161a and 162a are drawn out through the opened front surface of the lower half of the front cabinet 110.

**[0060]** The front cabinet 110 constructed as above is fixed to the upper portion of the base 130, and the front air inlet 104 is formed at the base 130.

**[0061]** A filter assembly 163 is preferably provided at the upper surface of the base 130, particularly, the upper side of the front air inlet 104. The filter assembly 163 purges the air sucked through the front air inlet 104.

**[0062]** The filter assembly 163 includes a plurality of filters 163a, 163b and 163c arranged up and down. Preferably, the filters are comprised of hepa-filters and high performance filters such as nano-filters that remove odor particles or bacilli.

**[0063]** Meanwhile, the rear cabinet 120 has an opened front surface and an opened bottom, and its horizontal section has a trapezoidal shape enlarged toward the front to improve space utility if the indoor unit is provided at a corner of a room.

**[0064]** An upper panel 121 downwardly slanted toward the rear to form a ceiling of the rear cabinet 120 is fixed to the upper portion of the rear cabinet 120.

**[0065]** A front door 170 is provided at the front of the aforementioned cabinet 100 to cover the front surface of the front cabinet 110.

**[0066]** One side at the lower end of the front door 170

is rotatably connected with the base 130 and one side at the upper end of the front door 170 is rotatably connected with the upper end of the front cabinet 110.

**[0067]** The front door 170 includes a glass 171, a door plate 172 provided at the rear of the glass 171, and a door frame 173. The door frame 173 is rotatably connected with the base 130 and the front cabinet 110 to support the glass 171 and the door plate 172.

**[0068]** The door plate 172 is provided with an opening hole 172a, and a display 174 is provided at the rear side of the door plate 172 to display various information such as driving information through the opening hole 172a and the glass 171.

**[0069]** Meanwhile, the blower 400 sucks the indoor air through the air inlets 104, 105 and 106 and forcibly urges air flow to allow the sucked air to be discharged out through the heat exchanger 300 and the air outlets 101, 102 and 103.

**[0070]** The blower 400 includes a blower housing 410 provided at the lower portion inside the cabinet 100 and a blower fan 420 provided inside the blower housing 410.

**[0071]** The blower housing 410 has an opened front surface to communicate with an orifice 430 that guides the air sucked through the air inlets. An air outlet hole 411 is formed at the upper surface of the blower housing 410 to discharge the air toward an upward direction where the heat exchanger 300 is positioned.

**[0072]** As an example of the blower fan 420, there is provided a turbo fan that axially sucks the air by means of driving of a blower motor 421 and radially discharges the air.

**[0073]** In addition, an electric dust collector 500 is preferably provided at the front of the orifice 430.

**[0074]** The electric dust collector 500 includes a high voltage generator 510, an ionizing portion 520, and a collecting portion 530.

**[0075]** The high voltage generator 510 applies a high voltage to the ionizing portion 520 to induce discharge. The ionizing portion 520 ionizes dust in the air using energy generated during discharge and irradiates light energy. The collecting portion 530 collects the ionized dust.

**[0076]** The heat exchanger 300 is provided at the upper side of the blower fan 420 slantingly from the front to the rear, and is comprised of a refrigerant pipe that passes through refrigerant and a plurality of fins provided in the refrigerant pipe. The heat exchanger 300 is connected with a refrigerant pipe (not shown) that guides to the outdoor unit the refrigerant evaporated or condensed by heat exchange with the air.

**[0077]** A fan 310 is arranged below the heat exchanger 300 to store condensed water therein. The condensed water is generated on the surface of the heat exchanger 300 and dropped. A drain hose (not shown) is connected to one side of the fan 310 to drain the condensed water outside the indoor unit.

**[0078]** Hereinafter, the left and right outlet doors 210 and 220 and the door driving gear 600 will be described with reference to FIG. 6 to FIG. 8.

**[0079]** Referring to FIG. 6 to FIG. 8, the door driving gear 600 includes a door transfer unit transferring the left and right outlet doors 210 and 220, and a driving portion driving the door transfer unit.

5 **[0080]** The door transfer unit transfers the left and right outlet doors 210 and 220 in a horizontal direction so that the left and right air outlets 101 and 102 are opened and closed.

10 **[0081]** To reciprocate the left and right outlet doors 210 and 220 in a horizontal direction, the door transfer unit in this embodiment is constructed in such a manner that it switches a rotational motion generated by the driving portion to a rectilinear motion and transfers the rectilinear motion to the air outlet doors 210 and 220. However, the door transfer unit is not limited to such construction.

**[0082]** In detail, the door transfer unit includes a first transfer body 610 provided at the left outlet door 210 and a second transfer body 620 provided at the right outlet door 220.

20 **[0083]** Preferably, the first transfer body 610 and the second transfer body 620 are rotatably connected to the left outlet door 210 and the right outlet door 220, respectively. However, the first and second transfer bodies are not limited to such case.

25 **[0084]** The first and second transfer bodies may be formed in a single body in the same manner as those of the second embodiment that will be described later. In this embodiment, the first transfer body 610 and the second transfer body 620 are separately provided to respectively transfer the left outlet door 210 and the right outlet door 220.

30 **[0085]** To this end, at least one or more hooks 611 and 621 are provided at any one of the left outlet door 210 and the first transfer body 610. At least one or more shafts 210a and 220a are provided at the other of the left outlet door 210 and the first transfer body 610 and caught in the hooks 611 and 621 to form rotational shafts, so that the left outlet door 210 is rotatably connected with the first transfer body 610 and at the same time the left outlet door 210 is detachably connected with the first transfer body 610.

35 **[0086]** In this embodiment, a plurality of the shafts 210a are provided at the right side end of the left outlet door 210, and a plurality of the hooks 611 respectively connected to the shafts 210a are provided at the left end of the first transfer body 610.

40 **[0087]** Preferably, the right outlet door 220 and the second transfer body 620 are connected with each other in the same manner as the left outlet door 210 and the first transfer body 610.

45 **[0088]** In other words, a plurality of the shafts 220a are provided at the left end of the right outlet door 220, and a plurality of the hooks 621 respectively connected to the shafts 220a are provided at the right end of the second transfer body 620.

50 **[0089]** In this way, the first transfer body 610 and the second transfer body 620 respectively connected to the left and right outlet doors 210 and 220 are preferably

driven by a single motor 183.

**[0090]** To this end, the first transfer body 610 includes a first door link portion 612 and a first rack bar 613. The first door link portion 612 is provided with the hooks 611 connected to the shafts 210a of the left outlet door. The first rack bar 613 is extended from the right side of the first door link portion 612 to the second transfer body 620 at a predetermined length.

**[0091]** The second transfer body 620 includes a second door link portion 622 and a second rack bar 623. The second door link portion 622 is provided with the hooks 621 connected to the shafts 220a of the right outlet door. The second rack bar 623 is extended from the left side of the second door link portion 622 to the first transfer body 610 at a predetermined length.

**[0092]** The first rack bar 613 and the second rack bar 623 are respectively provided with a first rack 613a and a second rack 623a. The first rack 613a and the second rack 623a are preferably engaged with a pinion gear 631 rotated by a motor 630. The motor 630 is provided in the driving portion. The pinion gear 631 may directly be fixed to a shaft of the motor 630 to simplify its structure. Therefore, the door transfer unit can be driven by the single motor 630.

**[0093]** In this embodiment, the driving portion including the motor 630 is provided at a middle portion of the fitting plate 160 provided with the door driving gear. The first rack bar 613 is provided below the pinion gear 631, and the second rack bar 623 is provided above the pinion gear 631 in parallel with the first rack bar 613.

**[0094]** In such case, the first rack 613a is formed along the upper side of the first rack bar 613 to be engaged with the lower end of the pinion gear 631, and the second rack 632a is formed along the lower side of the second rack bar 623 to be engaged with the upper end of the pinion gear 631.

**[0095]** Meanwhile, the door driving gear is provided with a guide that guides the door transfer unit.

**[0096]** An example of the guide includes guide bosses 641 and 642 and guide slots 651 and 652. The guide bosses 641 and 642 are formed at any one of the cabinet 100 and the door transfer unit. The guide slots 651 and 652 are longitudinally formed at the other of the cabinet 100 and the door transfer unit in a transfer direction of the door transfer unit.

**[0097]** Referring to FIG. 6 to FIG. 8, the guide slots 651 and 652 are formed at a part of the first transfer body 610 and the second transfer body 620, particularly, the door link portions 612 and 622.

**[0098]** The guide bosses 641 and 642 corresponding to the guide slots 651 and 652 are projected from the fitting plate 160 of the cabinet to the front and respectively inserted into the guide slots 651 and 652.

**[0099]** Therefore, the guide bosses 641 and 642 and the guide slots 651 and 652 guide the first transfer body 610 and the second transfer body 620 when the first transfer body 610 and the second transfer body 620 are transferred in a horizontal direction by rotation of the pin-

ion gear 631.

**[0100]** In addition, it is preferable that the guide further includes a support that guides the door transfer unit, i.e., the first transfer body 610 and the second transfer body 620 and at the same time prevents the first and second transfer bodies 610 and 620 from being detached from the door transfer unit.

**[0101]** As an example of the support, a first support rib 653a and a second support rib 653b are provided in the indoor unit of the air-conditioning system according to the present invention. The first support rib 653a supports one side of the first transfer body 610 while the second support rib 653b supports the second transfer body 620.

**[0102]** In more detail, the first support rib 653a is projected from the fitting plate 160 to the front to adjoin the lower side of the first rack bar 613 while the second support rib 653b is projected from the fitting plate 160 to the front to adjoin the upper side of the second rack bar 623.

**[0103]** Preferably, the first support rib 653a has a '∩' shaped vertical section to improve its strength and minimize friction. The second support rib 653b has a '□' shaped vertical section.

**[0104]** The first support rib 653a and the second support rib 653b constructed as above may be provided separately from the fitting plate 160 to be assembled into the fitting plate 160.

**[0105]** The support may be formed in a rotatable roller type, particularly a train wheel shaped roller type.

**[0106]** Meanwhile, the indoor unit of the air-conditioning system according to the present invention is preferably provided with a friction damper that minimizes friction between the door transfer unit and the cabinet 100.

**[0107]** The friction damper includes first and second slip ribs 661 and 662 projected at one side of the door transfer units 610 and 620 and the cabinet.

**[0108]** In this embodiment, the first slip rib 661 is formed at the rear side of the first transfer body 610, and the second slip rib 662 is formed at the rear side of the second transfer body 620.

**[0109]** More specifically, the slip ribs 661 and 662 are respectively formed at the rear sides of the first door link portion 612 and the second door link portion 622.

**[0110]** Further, the first door link portion 612 and the second door link portion 622 may respectively have bent portions 612a and 622a at a portion where the slip ribs 661 and 662 are formed. The bent portions 612a and 622a have a "L" shaped vertical section and are projected toward the rear.

**[0111]** Preferably, the slip ribs 661 and 662 are linearly in contact with the fitting plate 160 to minimize friction between the slip ribs 661 and 662 and the cabinet 100, particularly, between the slip ribs 661 and 662 and the front surface of the fitting plate 160.

**[0112]** The friction damper may be comprised of a roller (not shown) provided at least one side of the fitting plate 160 of the cabinet and the door transfer unit.

**[0113]** Meanwhile, the first transfer body 610 is preferably flush with the second transfer body 620 to mini-

mize a space occupied by the door transfer unit.

**[0114]** Preferably, the door transfer unit further includes an interference preventing portion that prevents interference between the first transfer body 610 and the second transfer body 620 when the left and right outlet doors 210 and 220 are opened.

**[0115]** The interference preventing portion includes a first interference preventing groove 614 and a second interference preventing groove 624. The first interference preventing groove 614 is formed in the first transfer body 610 to prevent interference with the second rack bar 623. The second interference preventing groove 624 is formed in the second transfer body 620 to prevent interference with the first rack bar 613.

**[0116]** In more detail, the first interference preventing groove 614 is formed in the first door link portion 612 while the second interference preventing groove 624 is formed in the second door link portion 622.

**[0117]** In addition to the above construction, it is preferable that the indoor unit of the air-conditioning system according to the present invention further includes a door guide that guides the left and right outlet doors 210 and 220.

**[0118]** The door guide includes door guide grooves 671a and 671b and door guide bosses 672a and 672b. The door guide grooves 671a and 671b are formed at any one side of the left and right outlet doors 210 and 220 and the cabinet while the door guide bosses 672a and 672b are formed at the other side of the left and right outlet doors 210 and 220 and the cabinet.

**[0119]** In this embodiment, the first door guide groove 671a is formed at the left air outlet 101, and the second door guide groove 671b is formed at the right air outlet 102. The left outlet door 210 is provided with the first door guide boss 672a that moves along the first door guide groove 671a while the right outlet door 220 is provided with the second door guide boss 672b that moves along the second door guide groove 671b.

**[0120]** In more detail, the respective door guide grooves 671a and 671b are longitudinally formed at the upper edges of the left and right air outlets 101 and 102 in left and right directions. The respective door guide bosses 672a and 672b are provided at the upper portions of the left and right outlet doors 210 and 220.

**[0121]** The operation of the aforementioned indoor unit of the air-conditioning system according to the present invention will now be described.

**[0122]** First, if the power is applied to the air-conditioning system and a cooling or heating driving mode is input, the door driving gear is driven so that the left and right outlet doors 210 and 220 are simultaneously opened by horizontal movement, and the upper door 230 is also opened.

**[0123]** More specifically, the left and right outlet doors 210 and 220 are transferred by the first and second transfer bodies 610 and 620, which are simultaneously transferred by rotation of the pinion gear 631, to respectively

open the left and right air outlets.

**[0124]** At the same time, the left inlet vanes 143 and 144 are respectively opened by rotation to open the left and right air inlets 105 and 106.

5 **[0125]** The indoor air is sucked into the cabinet through the respective air inlets 104, 105 and 106 as the blower 400 is driven.

**[0126]** The sucked air is purged while passing through the air filters 161a and 162a and the filter assembly 163 constituting an air purging system.

10 **[0127]** In more detail, the air sucked through the front air inlet 104 of the base 130 is purged while passing through the filters 163a, 163b and 163c provided in the filter assembly 163. The air sucked through the left and right air inlets 105 and 106 is purged while passing through the air filters 161a and 162a.

15 **[0128]** Next, the air that has passed through the air filters 161a and 162a and the filter assembly 163 passes through the electric dust collector 500 positioned at the front of the blower 400. The electric dust collector 500 ionizes dust in the air and odor particles and then collects the ionized dust and the ionized odor particles.

**[0129]** The air purged as above is blown toward the heat exchanger 300 by the blower 400 and is discharged into the indoor through the air outlets 101, 102 and 103 in a state that it is cooled or heated by heat exchange with the refrigerant flowing inside the heat exchanger, thereby carrying out room cooling or room heating.

20 **[0130]** At this time, the left and right wind vanes 141 and 142 control the discharged air.

**[0131]** If the operation of the air-conditioning system is stopped, the left and right outlet doors 210 and 220 are transferred in a horizontal direction by the first and second transfer bodies 610 and 620 transferred by rotation of the pinion gear 631 and at the same time are closed.

**[0132]** Furthermore, the upper door 230 and the left and right inlet vanes 143 and 144 are closed by the respective driving motors to prevent foreign matters from being blown into the cabinet 100.

30 **[0133]** Meanwhile, since the left and right outlet doors 210 and 220 are opened and closed by a single motor and the upper door 230 and the inlet vanes 143 and 144 are separately driven, whether to open and close the left and right outlet doors, the upper door and the inlet vanes depends on room cooling, room heating, and the air blowing amount for air purging.

**[0134]** Meanwhile, if the indoor unit is mainly driven for air purging, the left and right air inlets 105 and 106 are sealed and the air is sucked through the front air inlet 104 only.

35 **[0135]** Although an air purging mode may be carried out in a state that the air outlets 101, 102 and 103 are all opened, the left and right air outlets 101 and 102 are sealed by the left and right outlet doors 210 and 220 and the upper air outlet 103 is only opened considering balance with air suction.

40 **[0136]** Therefore, the air blown into the cabinet 100

through the front air inlet 104 is purged so that fine dust and odor particles are removed from the air while passing through the filter assembly 163 and the electric dust collector 500. Then, the air is discharged to the indoor place through the upper air outlet 103.

**[0137]** Now, the indoor unit of the air-conditioning system according to the second embodiment of the present invention will be described with reference to FIG. 9 and FIG. 10.

**[0138]** In the indoor unit of the air-conditioning system according to the second embodiment of the present invention, a left air inlet 105a is formed at the left slant surface 111b of the lower half of the cabinet, and a right air inlet 106a is formed at the right slant surface 113b of the lower half of the cabinet.

**[0139]** The left and right air inlets 105a and 106a may be opened and closed by an inlet door (not shown) operated in the same manner as that of the aforementioned left and right outlet doors 210 and 220.

**[0140]** The other construction and operation principles of the indoor unit according to the second embodiment are the same as those of the indoor unit according to the first embodiment. Therefore, their repeated description will be omitted.

**[0141]** Next, the indoor unit of the air-conditioning system according to the third embodiment of the present invention will be described with reference to FIG. 11 and FIG. 12.

**[0142]** In the indoor unit of the air-conditioning system according to the third embodiment of the present invention, the left and right inlet vanes 143 and 144 in the first embodiment are replaced with left and right inlet grills 145 and 146. The left and right inlet grills 145 and 146 are respectively provided in the left and right air outlets 105 and 106.

**[0143]** Preferably, the left and right inlet grills 145 and 146 are detachably provided.

**[0144]** The other construction and operation principles of the indoor unit according to the third embodiment are the same as those of the indoor unit according to the first embodiment. Therefore, their repeated description will be omitted.

**[0145]** Subsequently, the indoor unit of the air-conditioning system according to the fourth embodiment of the present invention will be described with reference to FIG. 13 and FIG. 14.

**[0146]** The indoor unit of the air-conditioning system according to the fourth embodiment of the present invention includes a left air outlet 101a and a right air outlet 102a respectively formed at the upper portions of the left and right sides 112a and 114a of the front cabinet.

**[0147]** The left air outlet 101a and the right air outlet 102a are respectively provided with a left outlet vane 141b and a right outlet vane 142b that are rotatable.

**[0148]** The left outlet vane 141b and the right outlet vane 142b control the wind of the air discharged from the left and right air outlets 101a and 102a and at the same time open and close the left and right air outlets 101a

and 102a, respectively.

**[0149]** Therefore, the door driving gear 180 is not required essentially.

**[0150]** Since the other construction and operation principles of the indoor unit according to the third embodiment are the same as those of the indoor unit according to the first embodiment, their repeated description will be omitted.

**[0151]** As described above, the indoor unit of the air-conditioning system according to the present invention has the following advantages.

**[0152]** First, in the indoor unit of the air-conditioning system according to the present invention, the conditioned air can be supplied to the indoor place uniformly and quickly.

**[0153]** Second, since the indoor unit of the air-conditioning system according to the present invention can be arranged properly depending on arrangement of furniture or indoor structure, it is possible to improve space utility.

**[0154]** Third, in the indoor unit of the air-conditioning system according to the first embodiment to the third embodiment of the present invention, since the conditioned air can quickly reach the user located at the front of the indoor unit, the indoor unit is provided at one side along a longitudinal direction of the room having the width narrower than the length, thereby quickly and uniformly supplying the conditioned air to the entire room.

**[0155]** Fourth, in the indoor unit of the air-conditioning system according to the first embodiment and the third embodiment of the present invention, since the left and right air outlets are formed at a portion different from that of the left and right air inlets, it is possible to prevent the air discharged from the cabinet from being mixed with the air sucked into the cabinet, thereby preventing the discharged air from again flowing into the cabinet.

**[0156]** Fifth, in the indoor unit of the air-conditioning system according to the fourth embodiment of the present invention, since the conditioned air can quickly reach the user located next to the indoor unit, the indoor unit is provided at a middle portion of a relatively long wall, thereby quickly and uniformly supplying the conditioned air to the entire room.

**[0157]** Sixth, in the indoor unit of the air-conditioning system according to the first embodiment, the third embodiment and the fourth embodiment of the present invention, since the left and right air inlets are respectively formed at both sides of the cabinet, it is possible to previously avoid any accident that may be caused when children play at the front of the indoor unit.

**[0158]** Finally, in the indoor unit of the air-conditioning system according to the present invention, since the left and right air outlets and the left and right air inlets are longitudinally formed in up and down directions, the conditioned air can uniformly be supplied to the user and air flow can be increased.

**[0159]** It will be apparent to those skilled in the art that various modifications and variations can be made in the present invention without departing from the scope of the



invention as defined by the claims. Thus, it is intended that the present invention covers the modifications and variations of this invention provided they come within the scope of the appended claims.

### Claims

1. An indoor unit of an air-conditioning system comprising:

a cabinet (100) having a front side, left and right side portions provided respectively at a left end and a right end of the front side;

a left and a right air outlet (101, 102) formed at upper portions of the left and right side portions, respectively;

a left and a right air inlet (105, 106) formed at lower portions of the left and right side portions, respectively; and

a heat exchanger received in the cabinet;

**characterised in that** the air-conditioning system further comprises:

a front door (170) that covers the front surface of the cabinet, and wherein the front door (170) is configured to open and close the front surface of the cabinet.

2. The indoor unit of an air-conditioning system according to claim 1, wherein the left and right air outlets (101, 102) are longitudinally formed in up and down directions at upper portions of the left and right side portions, respectively.
3. The indoor unit of an air-conditioning system according to claim 1, wherein the left and right air inlets (105, 106) are longitudinally formed in up and down directions at lower portions of the left and right side portions, respectively.
4. The indoor unit of an air-conditioning system according to claim 1, further comprising an upper air outlet (103) formed at the front of the upper side of the cabinet (100).
5. The indoor unit of an air-conditioning system according to claim 1, further comprising a front air inlet (104) formed at the lower end of the front of the cabinet (100).
6. The indoor unit of an air-conditioning system according to claim 1, wherein the cabinet (100) includes a front cabinet (110), a rear cabinet (120), and a base (130) supporting lower portions of the front and rear cabinets (110, 120).

7. The indoor unit of an air-conditioning system according to claim 6, wherein one side at the lower end of the front door (170) is rotatably connected with the base (130), and one side at the upper end of the front door (170) is rotatably connected with the upper end of the front cabinet (110).
8. The indoor unit of an air-conditioning system according to claim 7, wherein the front door (170) includes a glass (171), a door plate (172) provided at the rear of the glass (171), and a door frame (173) rotatably connected with the base (130) and the front cabinet (110) to support the glass (171) and the door plate (172).
9. The indoor unit of an air-conditioning system according to claim 8, wherein the door plate (172) is provided with an opening hole (172a), and a display (174) is provided at the rear side of the door plate (172) to display various information such as driving information through the opening hole (172a) and the glass (171).
10. The indoor unit of an air-conditioning system according to claim 6, wherein the lower front surface of the front cabinet (110) is opened to easily repair or clean various elements received in the cabinet (100).
11. The indoor unit of an air-conditioning system according to claim 1, further comprising a left and a right outlet vane (141, 142) that is respectively provided at the left and right air outlets (101, 102) to control the wind of the discharged air.
12. The indoor unit of an air-conditioning system according to claim 1, further comprising a left and a right outlet door (210, 220) provided at the cabinet (100) to open and close the left and right outlets, respectively, and a door driving gear (600) provided at the cabinet (100) to drive the left and right outlet doors (210, 220).
13. The indoor unit of an air-conditioning system according to claim 12, wherein the door driving gear (600) includes a door transfer unit transferring the left and right outlet doors (210, 220), and a driving portion driving the door transfer unit.
14. The indoor unit of an air-conditioning system according to claim 13, wherein the door transfer unit transfers the left and right outlet doors (210, 220) in a horizontal direction so that the left and right air outlets (101, 102) are opened and closed.
15. The indoor unit of an air-conditioning system according to claim 14, wherein the door transfer unit switches a rotational motion generated by the driving portion to a rectilinear motion, and transfers the rectilin-

ear motion to the air outlet doors (210, 220).

16. The indoor unit of an air-conditioning system according to claim 15, wherein the door transfer unit includes a first transfer body (610) provided at the left outlet door (210) to transfer the left outlet door (210), and a second transfer body (620) provided at the right outlet door (220) to transfer the right outlet door (220).

17. The indoor unit of an air-conditioning system according to claim 16, wherein the driving portion includes single motor (630), and wherein the first and second transfer bodies (610, 620) are driven by the single motor (630).

18. The indoor unit of an air-conditioning system according to claim 17, wherein the first transfer body (610) includes a first door link portion (612) provided with hooks (611) connected to shafts (210a) of the left outlet door (210), and a first rack bar (613) extended from the right side of the first door link portion (612) to the second transfer body (620) at a predetermined length; and

wherein the second transfer body (620) includes a second door link portion (622) provided with hooks (621) connected to shafts (220a) of the right outlet door (220), and a second rack bar (623) extended from the left side of the second door link portion (622) to the first transfer body (610) at a predetermined length,

wherein the first and second rack bars (613, 623) are respectively provided with a first and second rack (613a, 623a), and wherein the first and second racks (613a, 623a) are engaged with a pinion gear (631) rotated by the single motor (630).

19. The indoor unit of an air-conditioning system according to claim 12, further comprising an upper air outlet (103) formed at the front of the upper side of the cabinet (100), and an upper door (230) driven by a separated driving motor to open and close the upper air outlet (103).

#### Patentansprüche

1. Inneneinheit einer Klimaanlage, welche Folgendes aufweist:

eine Gehäuse (100) mit einer Vorderseite sowie linken und rechten Seitenabschnitten, welche jeweils an einem linken Ende und einem rechten Ende der Vorderseite vorgesehen sind;  
einen linken und einen rechten Luftaustritt (101, 102), welche jeweils an oberen Abschnitten der linken bzw. rechten Seitenabschnitte ausgebildet sind;

einen linken und einen rechten Lufteinlass (105, 106), welche jeweils an unteren Abschnitten der linken bzw. rechten Seitenabschnitte ausgebildet sind; und

einen Wärmetauscher, welcher in dem Gehäuse aufgenommen ist;

**dadurch gekennzeichnet, dass** die Klimaanlage des Weiteren Folgendes aufweist:

eine Fronttür (170), welche die Vorderfläche des Gehäuses abdeckt, und wobei die Fronttür (170) derart konfiguriert ist, dass sie die Vorderfläche des Gehäuses öffnet und schließt.

2. Inneneinheit einer Klimaanlage nach Anspruch 1, **dadurch gekennzeichnet, dass** der linke und rechte Luftaustritt (101, 102) der Länge nach in Aufwärts- und Abwärtsrichtung an oberen Abschnitten der linken bzw. rechten Seitenabschnitte ausgebildet sind.

3. Inneneinheit einer Klimaanlage nach Anspruch 1, **dadurch gekennzeichnet, dass** der linke und rechte Lufteinlass (105, 106) der Länge nach in Aufwärts- und Abwärtsrichtung an unteren Abschnitten der linken bzw. rechten Seitenabschnitte ausgebildet sind.

4. Inneneinheit einer Klimaanlage nach Anspruch 1, welche des Weiteren einen oberen Luftaustritt (103) aufweist, welcher an der Front bzw. Vorderseite der oberen Seite des Gehäuses (100) ausgebildet ist.

5. Inneneinheit einer Klimaanlage nach Anspruch 1, welche des Weiteren einen vorderen Lufteinlass (104) aufweist, welcher am unteren Ende der Front bzw. Vorderseite des Gehäuses (100) ausgebildet ist.

6. Inneneinheit einer Klimaanlage nach Anspruch 1, **dadurch gekennzeichnet, dass** das Gehäuse (100) ein vorderes Gehäuse (110), ein hinteres Gehäuse (120) sowie eine Basis bzw. Grundfläche (130) einschließt, welche die unteren Abschnitte des vorderen und hinteren Gehäuses (110, 120) stützt.

7. Inneneinheit einer Klimaanlage nach Anspruch 6, **dadurch gekennzeichnet, dass** eine Seite am unteren Ende der Fronttür (170) drehbar mit der Basis bzw. der Grundfläche (130) verbunden ist, und dass eine Seite am oberen Ende der Fronttür (170) drehbar mit dem oberen Ende des vorderen Gehäuses (110) verbunden ist.

8. Inneneinheit einer Klimaanlage nach Anspruch 7, **dadurch gekennzeichnet, dass** die Fronttür (170) Glas (171), eine an der Rückseite des Glases vorgesehene Türplatte (172) sowie einen Türrahmen (173) aufweist, welcher drehbar mit der Basis bzw.

- der Grundfläche (130) und dem vorderen Gehäuse (110) zur Stützung des Glases (171) und der Türplatte (172) verbunden ist.
9. Inneneinheit einer Klimaanlage nach Anspruch 8, **dadurch gekennzeichnet, dass** die Türplatte (172) eine Lochöffnung (172a) aufweist, und dass eine Anzeige (174) an der Rückseite der Türplatte (172) zum Anzeigen verschiedener Informationen wie beispielsweise Antriebsinformationen durch die Lochöffnung (172a) und das Glas (171) bereitgestellt ist.
10. Inneneinheit einer Klimaanlage nach Anspruch 6, **dadurch gekennzeichnet, dass** die untere vordere Fläche des vorderen Gehäuses (110) zur einfachen Reparatur oder Reinigung verschiedener in dem Gehäuse (100) aufgenommener Bauelemente geöffnet wird.
11. Inneneinheit einer Klimaanlage nach Anspruch 1, welche des Weiteren einen linken und einen rechten Auslassschieber (141, 142) aufweist, welche jeweils an dem linken bzw. rechten Luftaustritt (101, 102) zur Steuerung des Windes der Abluft bereitgestellt sind.
12. Inneneinheit einer Klimaanlage nach Anspruch 1, welche des Weiteren eine linke und eine rechte Austrittstür (210, 220) aufweist, welche an dem Gehäuse (100) zum Öffnen und Schließen des linken bzw. rechten Austritts bereitgestellt sind, sowie ein Türtriebwerk (600), welches an dem Gehäuse (100) zum Antrieb der linken und rechten Austrittstür (210, 220) bereitgestellt ist.
13. Inneneinheit einer Klimaanlage nach Anspruch 12, **dadurch gekennzeichnet, dass** das Tür-Triebwerk (600) eine Tür-Transfereinheit aufweist, welche die linke und rechte Austrittstür (210, 220) versetzt, sowie einen Antriebsabschnitt, welcher die Tür-Transfereinheit antreibt.
14. Inneneinheit einer Klimaanlage nach Anspruch 13, **dadurch gekennzeichnet, dass** die Tür-Transfereinheit die linke und rechte Austrittstür (210, 220) in eine horizontale Richtung versetzt, so dass der linke und rechte Luftaustritt (101, 102) geöffnet und geschlossen werden.
15. Inneneinheit einer Klimaanlage nach Anspruch 14, **dadurch gekennzeichnet, dass** die Tür-Transfereinheit eine Rotationsbewegung, welche von dem Antriebsabschnitt erzeugt wird, in eine geradlinige Bewegung umschaltet, und die geradlinige Bewegung zu den Luftaustrittstüren (210, 220) überträgt bzw. transferiert..
16. Inneneinheit einer Klimaanlage nach Anspruch 15, **dadurch gekennzeichnet, dass** die Tür-Transfereinheit einen ersten Transferkörper (610) aufweist, welcher an der linken Austrittstür (210) zur Versetzung der linken Austrittstür (210) bereitgestellt ist, sowie einen zweiten Transferkörper (620), welcher an der rechten Austrittstür (220) zur Versetzung der rechten Austrittstür (220) bereitgestellt ist.
17. Inneneinheit einer Klimaanlage nach Anspruch 16, **dadurch gekennzeichnet, dass** der Antriebsabschnitt einen Einzelmotor (630) einschließt, und dass der erste und zweite Transferkörper (610, 620) von dem Einzelmotor (630) angetrieben werden.
18. Inneneinheit einer Klimaanlage nach Anspruch 17, **dadurch gekennzeichnet, dass** der erste Transferkörper (610) einen ersten Türverbindungsabschnitt (612) einschließt, welcher mit Wellen (210a) der linken Austrittstür (210) verbundene Fanghaken (611) aufweist, sowie ein erstes Zahnstangengetriebe (613), welches sich von der rechten Seite des ersten Türverbindungsabschnitts (612) zu dem zweiten Transferkörper (620) eine vorher festgelegte Länge erstreckt; und dass der zweite Transferkörper (620) einen zweiten Türverbindungsabschnitt (622) einschließt, welcher mit Wellen (220a) der rechten Austrittstür (220) verbundene Fanghaken (621) aufweist, sowie ein zweites Zahnstangengetriebe (623), welches sich von der linken Seite des zweiten Türverbindungsabschnitts (622) zu dem ersten Transferkörper (610) eine vorher festgelegte Länge erstreckt, **dadurch gekennzeichnet, dass** das erste und zweite Zahnstangengetriebe (613, 623) jeweils eine erste und zweite Zahnstange (613a, 623a) aufweisen, und dass die erste und zweite Zahnstange (613a, 623a) mit einem Ausgleichskegelrad bzw. Ritzel (631) im Eingriff sind, welches von dem Einzelmotor (630) gedreht wird.
19. Inneneinheit einer Klimaanlage nach Anspruch 12, welche des Weiteren einen oberen Luftaustritt (103) aufweist, welcher an der Vorderseite der oberen Seite des Gehäuses (100) ausgebildet ist, sowie eine obere Tür (230), welche von einem separaten Antriebsmotor zum Öffnen und Schließen des oberen Luftaustritts (103) angetrieben wird.

## Revendications

1. Unité d'intérieur d'un système de conditionnement d'air comprenant:

un boîtier (100) ayant un côté avant, des portions latérales gauche et droite réalisées respectivement à une extrémité gauche et une extrémité droite du côté frontal;

une sortie d'air gauche et droite (101, 102) formée aux portions supérieures des portions latérales gauche et droite, respectivement;  
 une entrée d'air gauche et droite (105, 106) formée aux portions inférieures des portions latérales gauche et droite, respectivement; et  
 un échangeur de chaleur reçu dans le boîtier;

**caractérisée en ce que** le système de conditionnement d'air comprend en outre:

une porte avant (110) qui couvre la surface frontale du boîtier, et où la porte frontale (170) est configurée pour ouvrir et fermer la surface frontale du boîtier.

2. Unité d'intérieur d'un système de conditionnement d'air selon la revendication 1, dans laquelle les sorties d'air gauche et droite (101, 102) sont formées longitudinalement dans les directions vers le haut et vers le bas aux portions supérieures des portions latérales gauche et droite, respectivement.
3. Unité d'intérieur d'un système de conditionnement d'air selon la revendication 1, dans laquelle les entrées d'air gauche et droite (105, 106) sont formées longitudinalement dans les directions vers le haut et vers le bas aux portions inférieures des portions latérales gauche et droite, respectivement.
4. Unité d'intérieur d'un système de conditionnement d'air selon la revendication 1, comprenant en outre une sortie d'air supérieure (103) formée à l'avant du côté supérieur du boîtier (100).
5. Unité d'intérieur d'un système de conditionnement d'air selon la revendication 1, comprenant en outre une entrée d'air frontale (104) formée à l'extrémité inférieure de l'avant du boîtier (100).
6. Unité d'intérieur d'un système de conditionnement d'air selon la revendication 1, dans laquelle le boîtier (100) comporte un boîtier avant (110), un boîtier arrière (120) et une base (130) supportant les portions inférieures des boîtiers avant et arrière (110, 120).
7. Unité d'intérieur d'un système de conditionnement d'air selon la revendication 6, dans laquelle un côté à l'extrémité inférieure de la porte avant (170) est relié d'une manière tournante à la base (130), et un côté à l'extrémité supérieure de la porte frontale (170) est relié d'une manière tournante à l'extrémité supérieure du boîtier avant (110).
8. Unité d'intérieur d'un système de conditionnement d'air selon la revendication 7, dans laquelle la porte frontale (170) comporte une vitre (171), une plaque de porte (172) réalisée à l'arrière de la vitre (171) et

un châssis de porte (173) relié d'une manière tournante à la base (130) et au boîtier avant (110) pour supporter la vitre (171) et la plaque de porte (172).

- 5 9. Unité d'intérieur d'un système de conditionnement d'air selon la revendication 8, dans laquelle la plaque de porte (172) est munie d'un trou d'ouverture (172a), et un affichage (174) est prévu au côté arrière de la plaque de porte (172) pour afficher diverses informations, comme l'information d'entraînement, à travers le trou d'ouverture (172a) et la vitre (171).
- 10 10. Unité d'intérieur d'un système de conditionnement d'air selon la revendication 6, dans laquelle la surface frontale inférieure du boîtier avant (110) s'ouvre pour réparer ou nettoyer facilement divers éléments reçus dans le boîtier (100).
- 15 11. Unité d'intérieur d'un système de conditionnement d'air selon la revendication 1, comprenant en outre une aube de sortie gauche et droite (141, 142) qui est réalisée respectivement aux sorties d'air gauche et droite (101, 102) pour commander le vent de l'air évacué.
- 20 12. Unité d'intérieur d'un système de conditionnement d'air selon la revendication 1, comprenant en outre une porte de sortie gauche et droite (210, 220) réalisée au boîtier (100) pour ouvrir et fermer les sorties gauche et droite, respectivement, et une roue dentée d'entraînement de porte (600) réalisée au boîtier (100) pour entraîner les portes de sortie gauche et droite (210, 220).
- 25 13. Unité d'intérieur d'un système de conditionnement d'air selon la revendication 12, dans laquelle la roue dentée d'entraînement de porte (600) comporte une unité de transfert de porte transférant les portes de sortie gauche et droite (210, 220), et une portion d'entraînement entraînant l'unité de transfert de porte.
- 30 14. Unité d'intérieur d'un système de conditionnement d'air selon la revendication 13, dans laquelle l'unité de transfert de porte transfère les portes de sortie gauche et droite (210, 220) dans une direction horizontale de sorte que les sorties d'air gauche et droite (101, 102) sont ouvertes et fermées.
- 35 15. Unité d'intérieur d'un système de conditionnement d'air selon la revendication 14, dans laquelle l'unité de transfert de porte commute un mouvement de rotation produit par la portion d'entraînement en un mouvement rectiligne et transfère le mouvement rectiligne aux portes de sortie d'air (210, 220).
- 40 16. Unité d'intérieur d'un système de conditionnement d'air selon la revendication 15, dans laquelle l'unité
- 45
- 50
- 55

de transfert de porte comporte un premier corps de transfert (610) réalisé à la porte de sortie gauche (210) pour transférer la porte de sortie gauche (210), et un deuxième corps de transfert (620) réalisé à la porte de sortie droite (220) pour transférer la porte de sortie droite (220). 5

17. Unité d'intérieur d'un système de conditionnement d'air selon la revendication 16, dans laquelle la portion d'entraînement comporte un moteur unique (630), et dans laquelle les premier et deuxième corps de transfert (610, 620) sont entraînés par le moteur unique (630). 10
18. Unité d'intérieur d'un système de conditionnement d'air selon la revendication 17, dans laquelle le premier corps de transfert (610) comporte une première portion d'articulation de porte (612) présentant des crochets (611) reliés à des arbres (210a) de la porte de sortie gauche (210), et un premier porte-encoches (613) s'étendant du côté droit de la première portion d'articulation de porte (612) au deuxième corps de transfert (620) à une longueur prédéterminée; et 15
- dans laquelle le deuxième corps de transfert (620) comporte une deuxième portion d'articulation de porte (622) munie de crochets (621) reliés à des arbres (220a) de la porte de sortie droite (220), et un deuxième porte-encoches (623) s'étendant du côté gauche de la deuxième portion d'articulation de porte (622) au premier corps de transfert (610) à une longueur prédéterminée, 20
- où les premier et deuxième porte-encoches (613, 623) sont respectivement munis d'une première et deuxième crémaillère (613a, 623a) et dans laquelle les première et deuxième crémaillères (613a, 623a) viennent en prise avec un pignon (631) entraîné en rotation par le moteur unique (630). 25
19. Unité d'intérieur d'un système de conditionnement d'air selon la revendication 12, comprenant en outre une sortie d'air supérieure (103) formée à l'avant du côté supérieur du boîtier (100), et une porte supérieure (230) entraînée par un moteur d'entraînement séparé pour ouvrir et fermer la sortie d'air supérieure (103). 30

50

55

FIG. 1

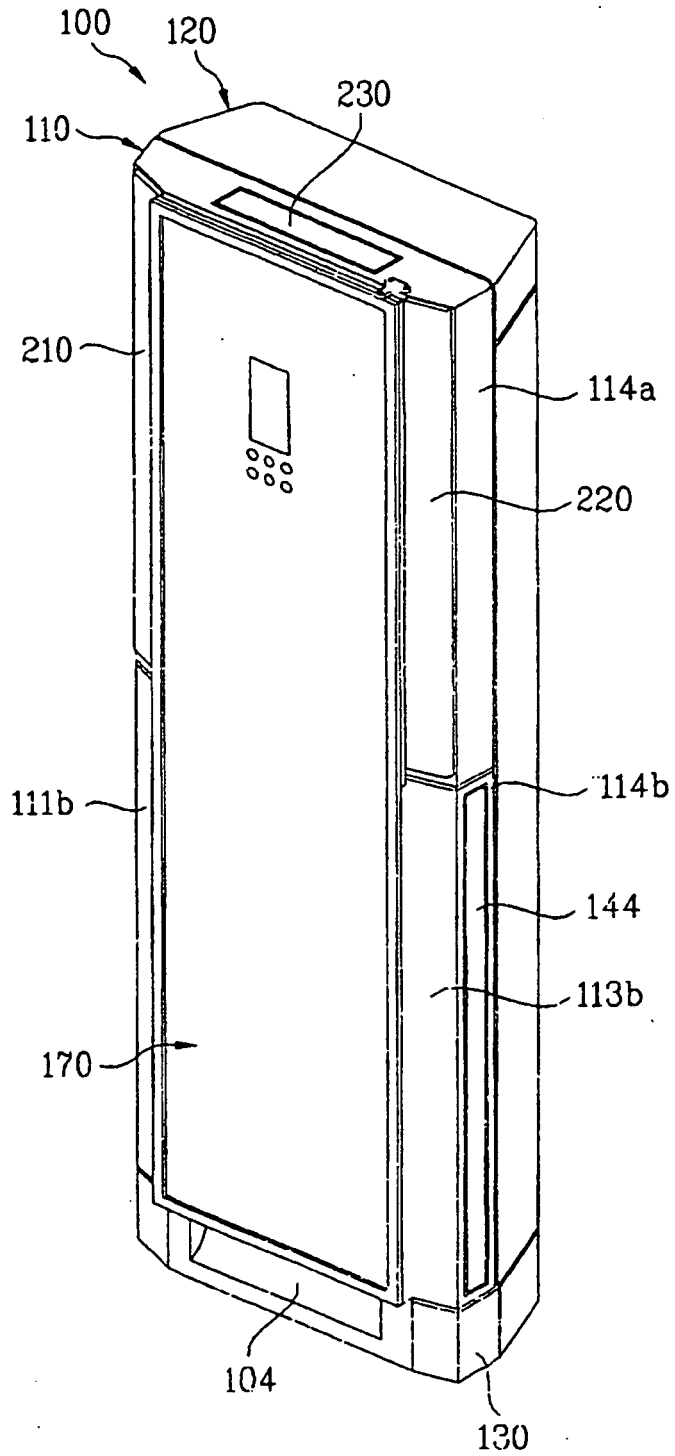

FIG. 2

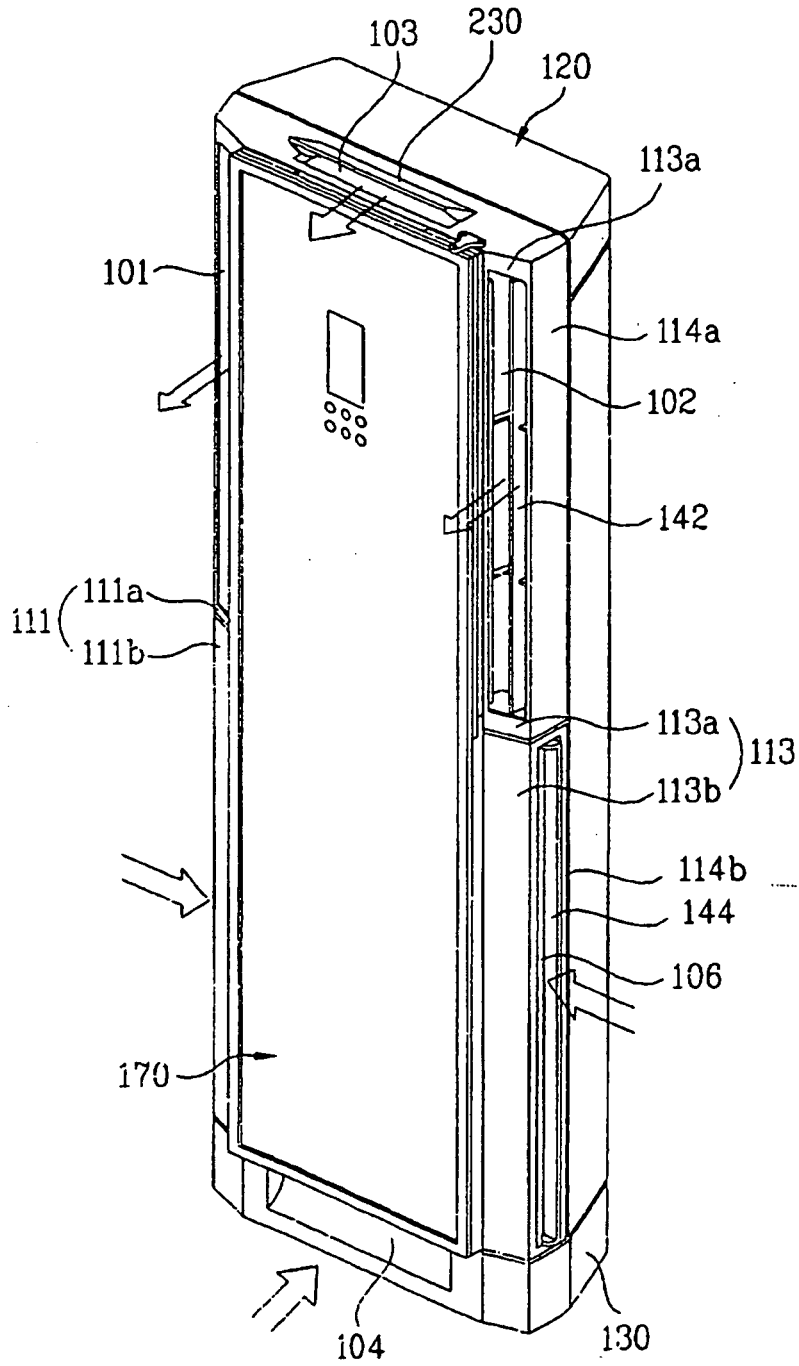

FIG. 3

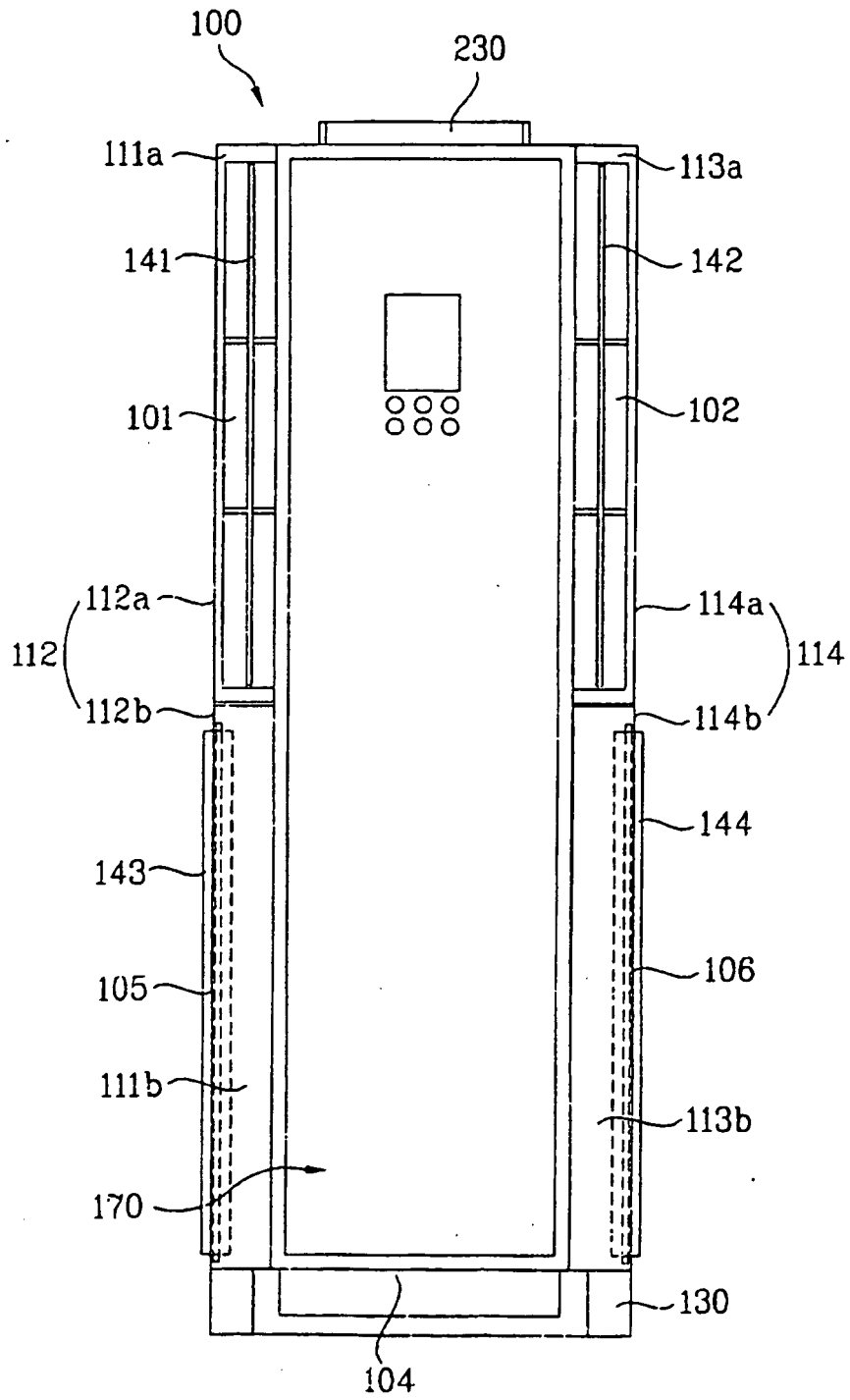





FIG. 5

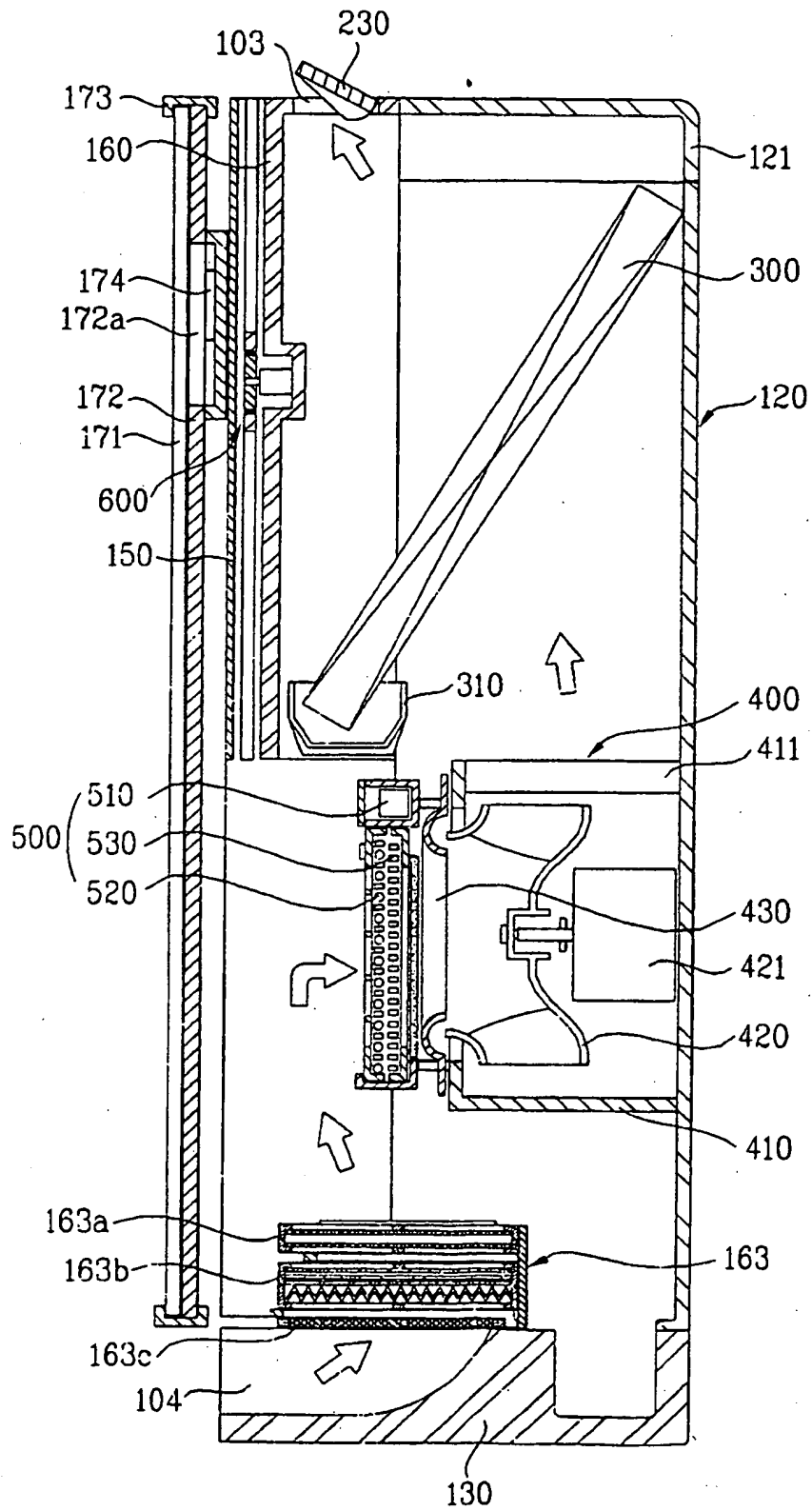

FIG. 6

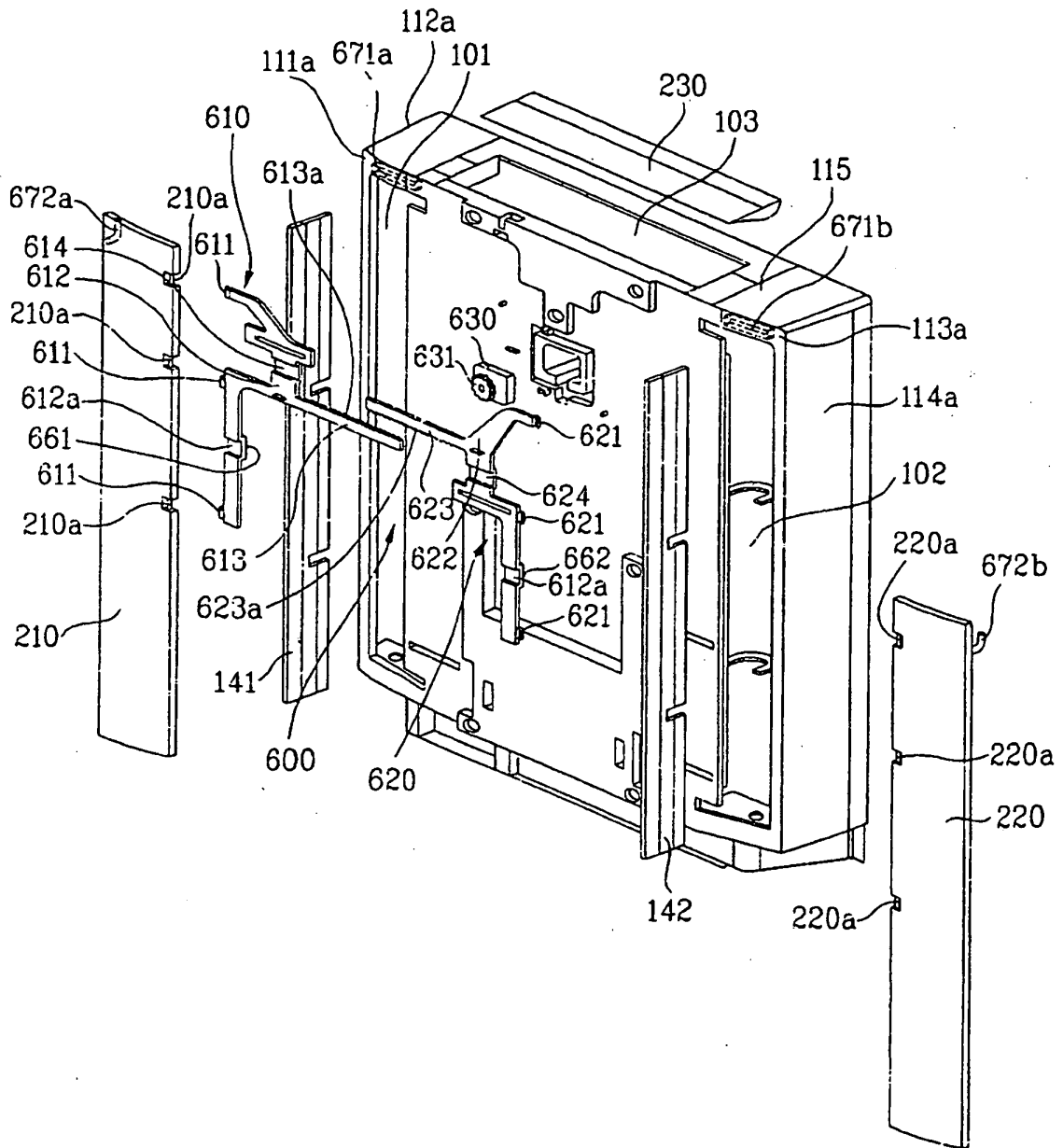

FIG. 7

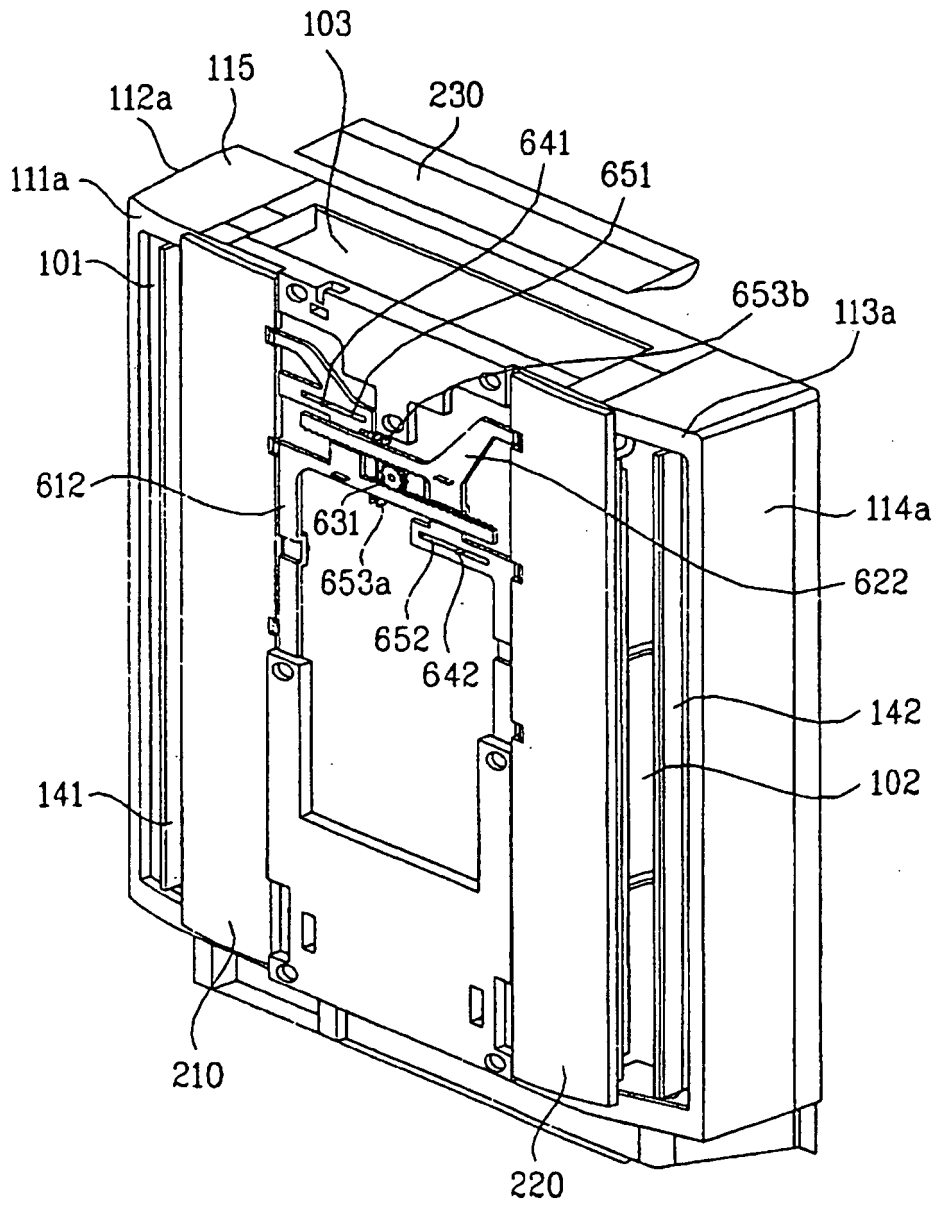

FIG. 8

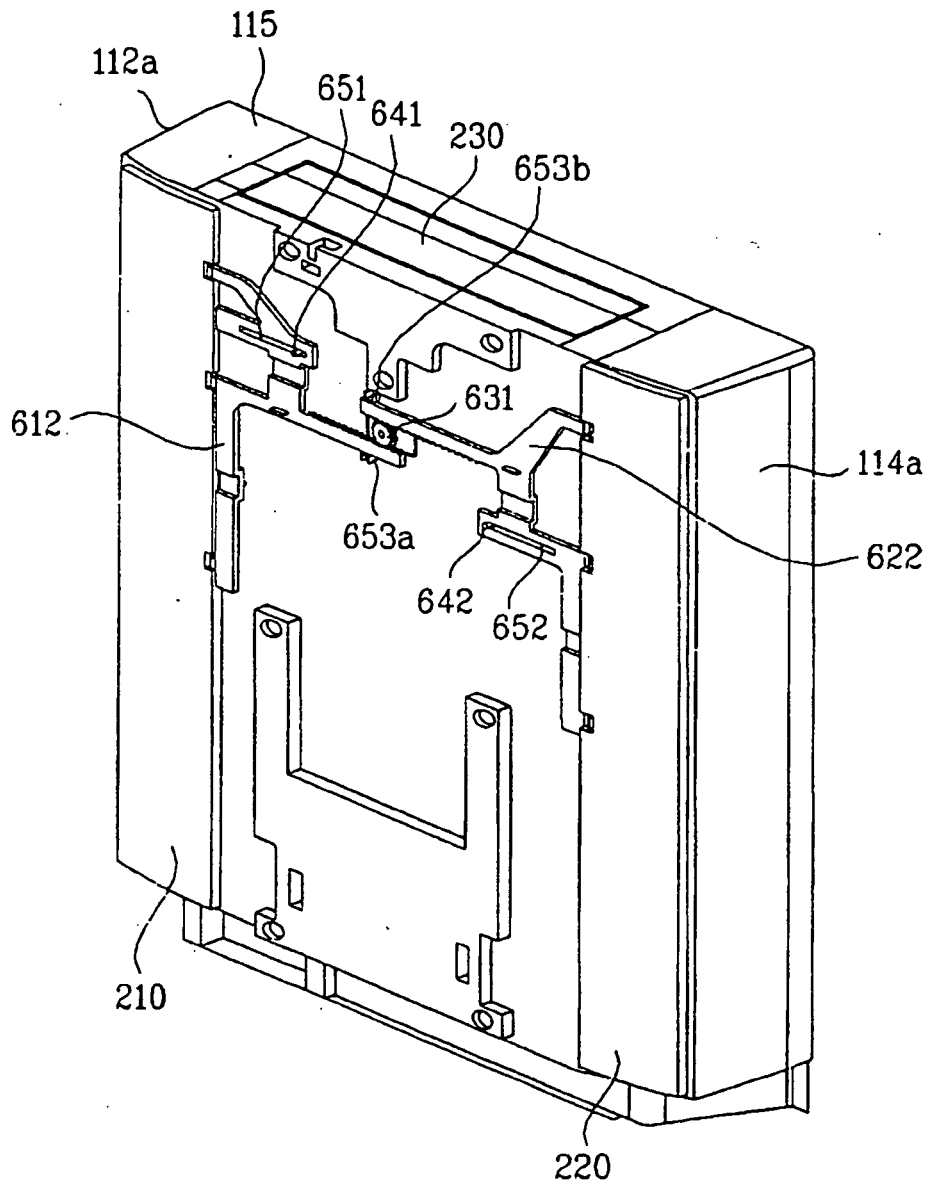



FIG. 10

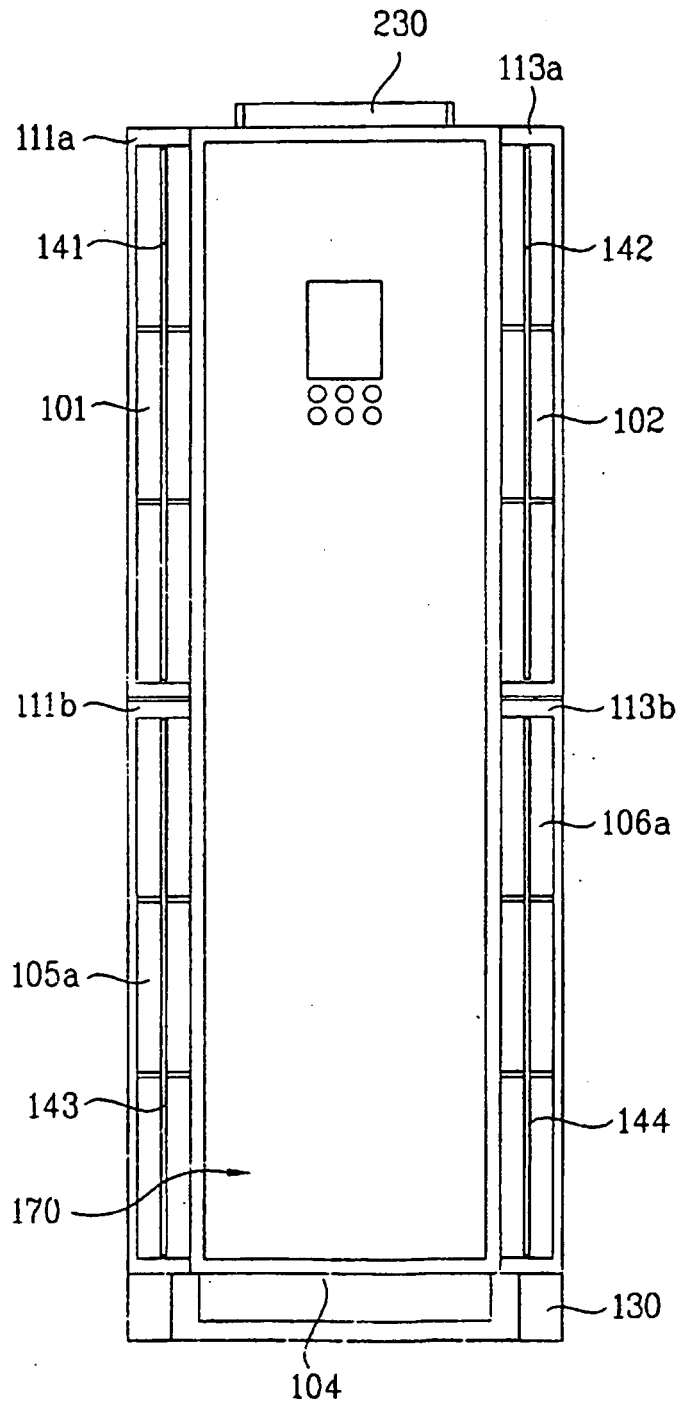

FIG. 11

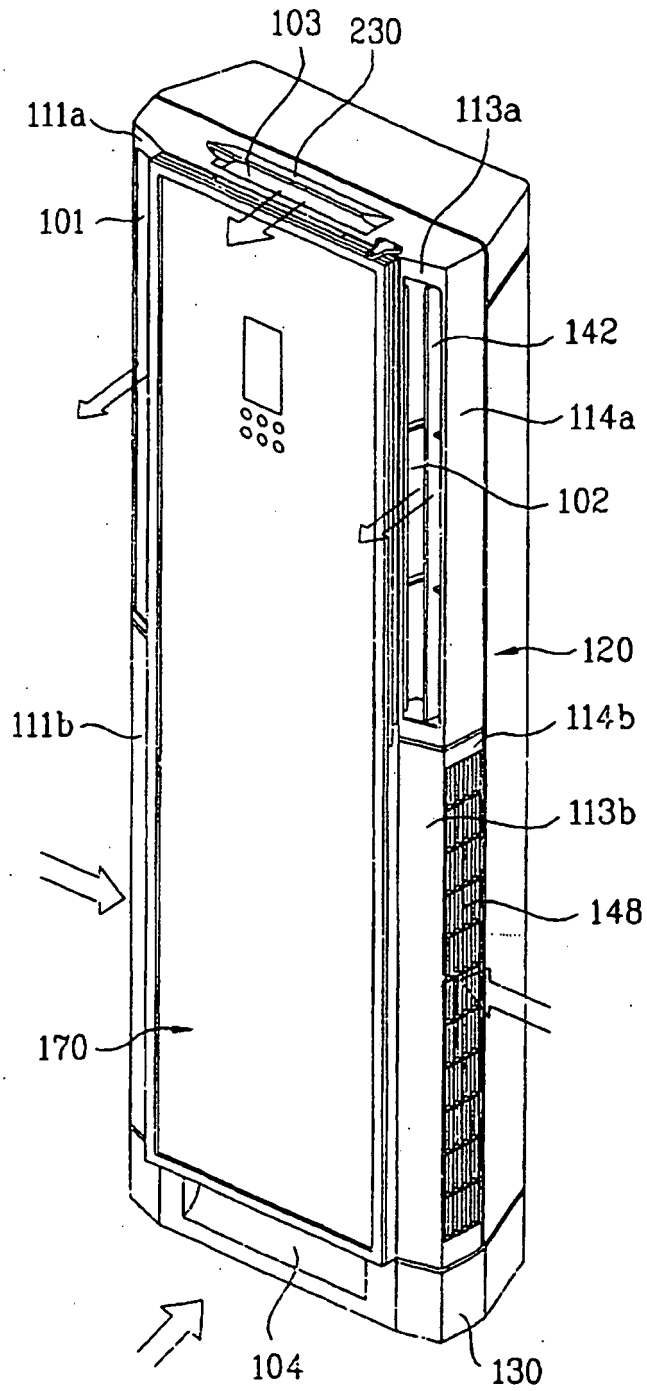



FIG. 12

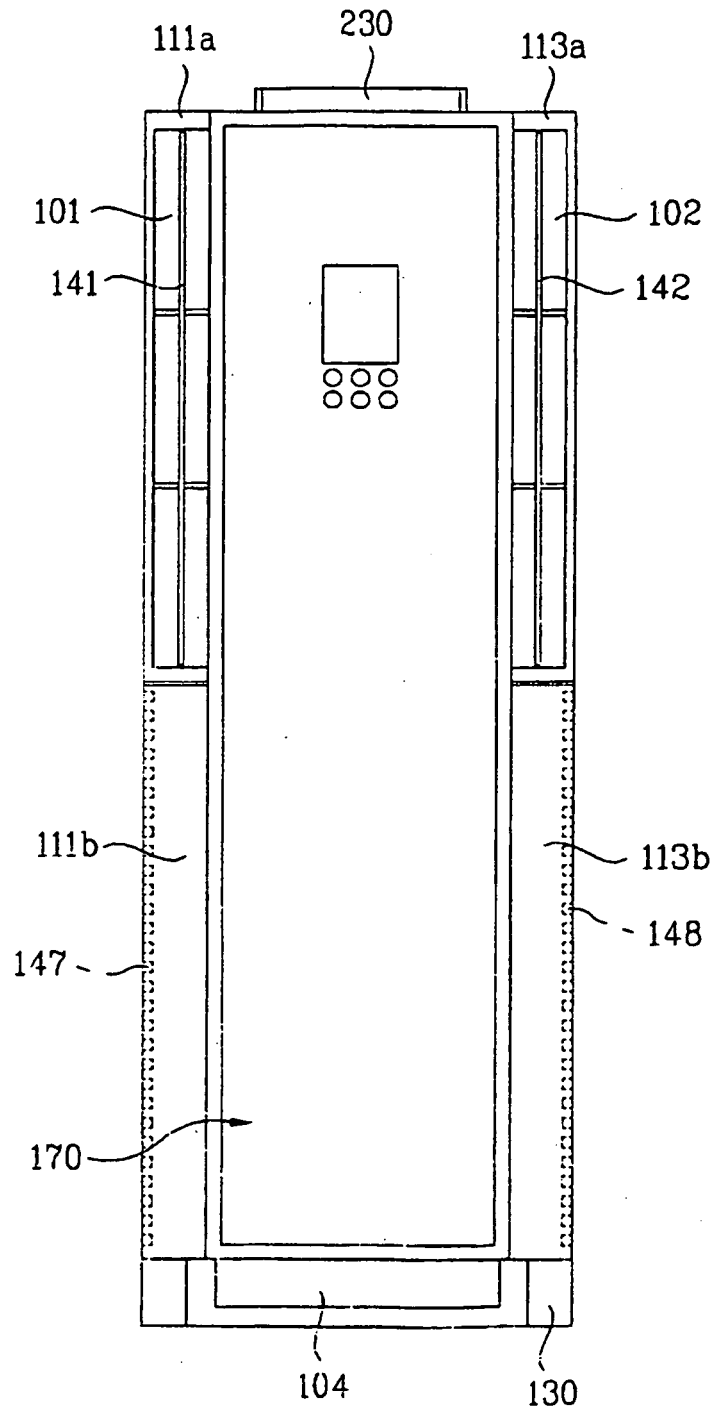

FIG. 13

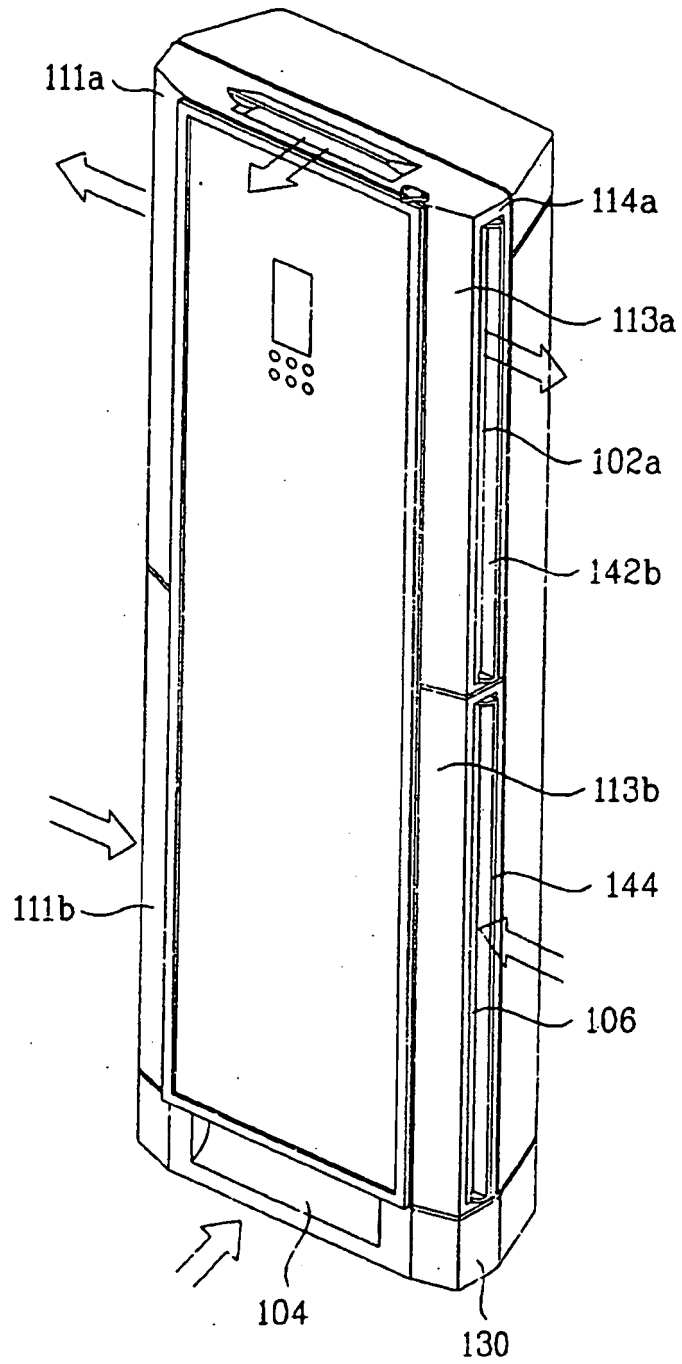
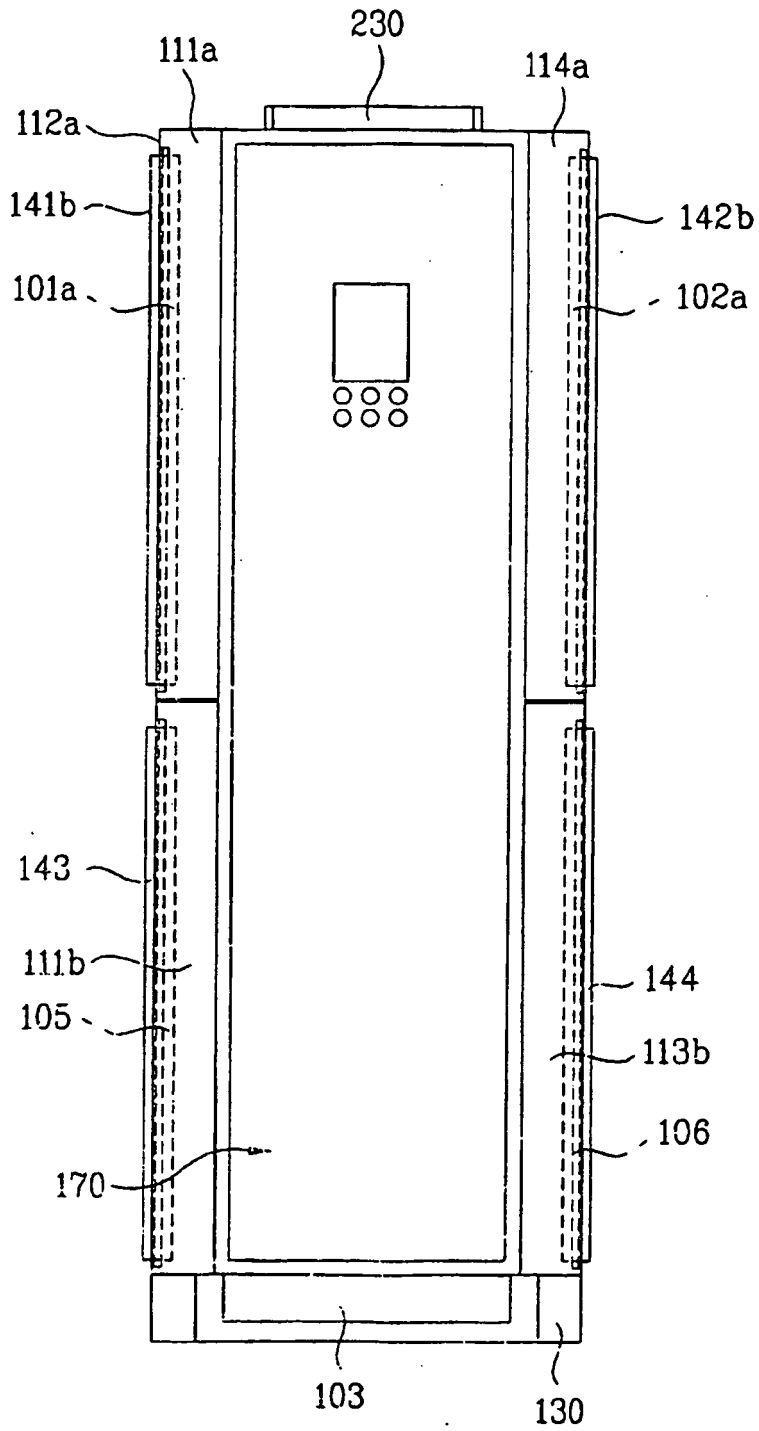

FIG. 14



**REFERENCES CITED IN THE DESCRIPTION**

*This list of references cited by the applicant is for the reader's convenience only. It does not form part of the European patent document. Even though great care has been taken in compiling the references, errors or omissions cannot be excluded and the EPO disclaims all liability in this regard.*

**Patent documents cited in the description**

- JP 2003156226 B [0008]
- JP 2003343871 A [0009]