

(12) PATENT
(19) AUSTRALIAN PATENT OFFICE

(11) Application No. AU 199890096 B2
(10) Patent No. 743210

(54) Title
Support system for banners

(51)⁷ International Patent Classification(s)
G09F 017/00

(21) Application No: **199890096**

(22) Application Date: **1998.08.18**

(87) WIPO No: **WO99/09542**

(30) Priority Data

(31) Number	(32) Date	(33) Country
328588	1997.08.19	NZ

(43) Publication Date : **1999.03.08**

(43) Publication Journal Date : **1999.05.06**

(44) Accepted Journal Date : **2002.01.24**

(71) Applicant(s)
Anthony James McKendry

(72) Inventor(s)
Anthony James McKendry

(74) Agent/Attorney
AHEARN FOX,GPO Box 1149,BRISBANE QLD 4001

(56) Related Art
WO 97/14132
WO 93/11521
AU 11411/95



<p>(51) International Patent Classification⁶ : G09F 17/00</p>	<p>A1</p>	<p>(11) International Publication Number: WO 99/09542 (43) International Publication Date: 25 February 1999 (25.02.99)</p>
<p>(21) International Application Number: PCT/NZ98/00123 (22) International Filing Date: 18 August 1998 (18.08.98) (30) Priority Data: 328588 19 August 1997 (19.08.97) NZ (71)(72) Applicant and Inventor: McKENDRY, Anthony, James [NZ/NZ]; 33 Pinny Avenue, Lower Hutt (NZ). (74) Agents: CUNNINGHAM, Annette, Jean et al.; Remming- ton-Piper, 11 Kings Crescent, Lower Hutt (NZ).</p>	<p>(81) Designated States: AL, AM, AT, AU, AZ, BA, BB, BG, BR, BY, CA, CH, CN, CU, CZ, DE, DK, EE, ES, FI, GB, GE, GH, GM, HR, HU, ID, IL, IS, JP, KE, KG, KP, KR, KZ, LC, LK, LR, LS, LT, LU, LV, MD, MG, MK, MN, MW, MX, NO, PL, PT, RO, RU, SD, SE, SG, SI, SK, SL, TJ, TM, TR, TT, UA, UG, US, UZ, VN, YU, ZW, ARIPO patent (GH, GM, KE, LS, MW, SD, SZ, UG, ZW), Eurasian patent (AM, AZ, BY, KG, KZ, MD, RU, TJ, TM), European patent (AT, BE, CH, CY, DE, DK, ES, FI, FR, GB, GR, IE, IT, LU, MC, NL, PT, SE), OAPI patent (BF, BJ, CF, CG, CI, CM, GA, GN, GW, ML, MR, NE, SN, TD, TG).</p> <p>Published <i>With international search report.</i></p>	

(54) Title: SUPPORT SYSTEM FOR BANNERS

(57) Abstract

A support stand is provided for the presentation of banners (5) in a free standing and substantially vertical orientation, wherein the stand comprises a base portion of preferably two spaced apart elongate support members joined by a connecting member which maintains the support members in a spaced apart relationship, each support member having means for accepting the end of a flexible support rod (11), each accepting means being spaced from one end of the respective support member, means for attaching an elongate banner to one end of each support member so that it extends substantially vertically therefrom, said banner being held in said vertical orientation by two flexible rods (11), one end of each rod engaging said accepting means, the other end of each rod being attached to a top edge of the banner, so that the rods are curved and in tension. The flexible support rods are preferably composed of two or three interconnecting rods (12, 13, 14), and the connecting member is optionally fitted with suction cups. The support stand can provide for banners of varying length and width.

The diagram illustrates a support system for banners. It features a base (5) with two vertical support members (7) connected at the bottom. Flexible support rods (11) are attached to the top of the stand and extend upwards to support a banner (5). The rods are composed of interconnecting segments (12, 13, 14). Arrows indicate the tension and orientation of the rods and the banner.

SUPPORT SYSTEM FOR BANNERS

Field of the Invention

5 The invention relates to a freestanding support system for lightweight banner materials. In particular it relates to a freestanding support system which is readily portable, and is adapted to provide for banners of more than one height or width.

10 Background to the Invention

It has been a common practise up until now, for display banners to be hung from a wall or ceiling. If they need to be independently hung in a self-supporting fashion, then freestanding solid metal frame units have been the only available support system.

15

The problem with the wall or ceiling hung unit is that it cannot be moved easily, and very often property is damaged during the installation process. The freestanding banner support systems currently in use are mainly of steel or a similar alloy and completely surround the banner. They are heavy and bulky to
20 transport and detract from the banner's message by their 'obtrusive' presence.

25

An attempt has been made at overcoming this problem by way of a lightweight and movable bannerstand using a carbon fibre flexible rod system, where the supporting rods are crossed. However, this system has several drawbacks in that the 'crossover' rod design is complicated and fiddly to operate, only one height is available, and only one width is available per system. Furthermore the system is expensive as the carbon fibre rods with their interconnecting internal strings are very costly to produce and ultimately, retail to the end consumer. Finally, there is no way to secure the unit from moving when bumped.

30

There is a need for a support system for banners which is portable, unobtrusive and relatively inexpensive.

Object

- 5 It is an object of the present invention is to provide an improved support system for banners, or at least to provide the public with a useful choice.

Statement of Invention

10 In a first aspect the invention provides a support stand for a banner comprising a base portion having accepting means for accepting at least one flexible support rod, means for attachment of an elongate banner to said base portion so that it extends substantially vertically therefrom, said banner being held in said vertical orientation by at least one flexible rod, one end of said rod engaging said accepting means, the other end of said rod being attached to a top edge of
15 said banner attachment means so that said rod is curved and in tension.

According to another aspect of the invention there is provided a support stand for a banner comprising two spaced apart elongate support members joined by a connecting member which maintains the support members in a spaced apart
20 relationship, each support member having means for accepting the end of a flexible support rod, each accepting means being spaced from one end of the respective support member, means for attaching an elongate banner to one end of each support member so that it extends substantially vertically therefrom, said banner being held in said vertical orientation by two flexible rods, one end
25 of each rod engaging said accepting means, the other end of each rod being attached to a top edge of said banner attachment means, so that the rods are curved and in tension.

Preferably the flexible support rods are comprised of a plurality of interconnecting flexible rods. In the most preferred options the flexible support rods are comprised of either two or three interconnecting flexible rods.

- 5 Optionally the connecting member is provided with suction cups for securing the support system to the ground surface.

Preferably the accepting means is a tube adapted to receive an end of the said flexible rod.

10

Preferably the connecting member is secured to the support members by means of an angled tab at each end, adapted to fit into a receiving projection attached to each support member.

- 15 Preferably a banner is attached to the support system by means of upper and lower cross rods threaded through the banner at each end.

The flexible support rods are prepared from materials, such that, when the rods are not under tension, as in when they are not in use in supporting a banner, they revert to being substantially straight. Preferably the rods are produced from
20 several composite materials, with fibre glass being a main component. However, it is envisaged as within the scope of this invention that the rods may be made from any suitable flexible material which bends readily under tension, but returns to being substantially straight when the tension is removed.

25

Preferably the support members and connecting member are prepared from lightweight metals which may be powder coated, although it is within the scope of the invention that any other suitable material may be used.

In another aspect of the invention there is provided a support stand for a banner comprising two spaced apart elongate support members joined by a connecting member which maintains the support members in a spaced apart relationship, each support member having means for accepting the end of a flexible support rod, each accepting means being spaced from one end of the respective support member, means for attaching an elongate banner to one end of each support member so that it extends substantially vertically therefrom, said banner being held in said vertical orientation by two flexible rods, one end of each rod engaging said accepting means, the other end of each rod being attached to a top edge of the banner attachment means, so that the rods are curved and in tension, wherein the support stand is disassembled into its component parts including two support members, a connecting member, a plurality of flexible rods and means for attachment of a banner.

Optionally the support system is provided with an accompanying storage bag into which the component parts can be readily fitted, and assembled on removal from the bag.

In yet a further aspect of the invention there is provided a method of supporting a banner in a free standing, substantially vertical orientation comprising attaching said banner to a support system comprising two spaced apart elongate support members joined by a connecting member which maintains the support members in a spaced apart relationship, each support member having means for accepting the end of a flexible support rod, each accepting means being spaced from one end of the respective support member, means for attaching an elongate banner to one end of each support member so that it extends substantially vertically therefrom, said banner being held in said vertical orientation by two flexible rods, one end of each rod engaging said accepting means, the other end of each rod being attached to a top edge of the banner attachment means, so that the rods are curved and in tension.

The support system is adapted to accommodate banners of different heights and widths. Variable heights of banners may be accommodated by varying the lengths and numbers of interconnecting flexible rods used to support the banner. In a most preferred version of the invention two heights of banner are catered for, being 1.5m when each flexible rod is comprised of two interconnecting rods, and a height of 2.15m when each flexible rod is comprised of three interconnecting rods.

Banners of different widths can be accommodated as the support system is adapted to receive cross bars of varying width. Preferably the banner widths are between 60cm and 100cm.

These and other aspects of the invention, which should be considered in all its novel aspects, will become apparent by way of the following description, which is given by way of example only, with reference to the accompanying drawings, in which:

Figure 1 is an isometric view of the base unit of the support system.

Figure 2 is an isometric view of the attachment of the cross member to the support member.

Figure 3 is a side view of the connecting member and optional suction cup.

Figure 4 is an isometric view of the assembled support stand and banner.

Figure 5 is an exploded view of the interconnecting support rods.

In a preferred embodiment of the invention the base unit of the support stand comprises the left and right support members (1) and the connecting member (2), which can be made of basic lightweight metals, then powder coated. The bottom of both support members has a semi-circular cutaway section(4) at the front end allowing for the lower banner rod (7), to be placed underneath. The rod, prior to this, has been inserted in a loop provided in the bottom of the banner(5). The bottom of both the left and right support members is flat with a gentle curved top rising to a maximum height around the centre of its length. Adjacent to the centre, on the inside edge of the curved portion of the support members is a small tube(6) acting as base receptacle for the flexible support rods. This tube is inclined at such a backward angle so as to create sprung tension in the flexible rods when connection is made to the top banner at cross rod (7).

The connecting member(2) provides both rigidity and support for both side support members, plus a platform for the suction cups if they are employed. These cups, when attached to a flat surface, assist in deterring the support system from moving. They are held in place by a wing nut atop connecting member, and a securing nut(8) underneath. At either end of the connecting member is an angled tab (9), which neatly slips into a flat shaped projection(10) attached to the left and right support members.

In total there are provided six interconnecting flexible rods (12), (13) and (14), and either two or three may be employed on each side to form the complete flexible support rod(11). The middle and top rods(13) and (14), are of equal length, whilst the lower rods(12), are slightly longer. The rod material is constructed of several composite materials, fibreglass being the main substance. A unidirectional pattern provides good flexibility and pretension when 'bent'. There is high tensile strength, and excellent 'memory' when the rods are returned to the straight position. The bottom flexible rod(12), has a sleeve at

one end (12a). The unsleeved end is inserted into the support members (1) by way of the tube(6). The sleeved end receives the unsleeved centre rod (13). At the other end of the center rod is another sleeve (13a), which receives the top rod's(14) unsleeved end. At the end of the top rod is a curved cup-like shape(16) that is slipped under the top banner cross rod (7). By removing the
5 centre rod(13) and connecting the top rod(14) to the bottom rod(12),the support stand is adapted to provide for a banner of a different height. The invention, in this way, is able to provide a support stand for two different heights of banner.

10 The banner support cross rods (7), are of the same material as the support rods (11), and come in differing lengths, depending on banner width requirements.

In the preferred method of assembly of the support stand the two support members(1), are connected by clipping the connecting member to them by
15 means of the angled tab(9) and the projection(10). The banner cross rods(7) are the inserted into the sleeves provided at the upper and lower ends of the banner(5), and the lower banner cross rod is inserted into the semi-circular cut-away sections(4), on each support member(1). The required number of flexible rods are then joined to provide the flexible support rod(11), which is inserted
20 into the support member by way of the tube(6) provided to receive it. The rod is then compressed so as to enable it to clip into the upper banner cross rod(7) by way of the hook(16).

The result is a constant pre-tensioning of the banner. Light pressure is
25 constantly exerted on the banner. The support stand is thus virtually invisible from a front-on angle, and only slightly visible at other angles. This gives more emphasis to the image being promoted on the actual banner.

The whole assembly then forms a compact unit which is easily dismantled and
30 packed away into a lightweight tote bag.

WHAT I CLAIM IS

1. A support stand assembly for displaying a banner comprising:
 - an upper transverse rod and a lower transverse rod;
 - two flexible support rods;
 - a base including two elongate support members removably joined by a transverse connecting member to maintain the support members in a spaced apart relationship, each support member having female receiving means spaced from and inclined toward a first end thereof to removably receive a first end of one flexible support rod, and means on or adjacent a second end thereof for receiving an end of said lower transverse rod; and
 - means for removably attaching a second end of each flexible support rod to the said upper transverse rod;
 - such that when the upper and lower ends of a banner are attached to the upper and lower transverse rods respectively, each end of the lower transverse rod is received in each said support member, and each flexible support rod is attached to the said support member and said upper transverse rod the banner is displayed in substantially upright orientation and the flexible support rods are not in contact and are curved and under compression.
2. A support stand as claimed in claim 1 wherein each flexible support rod is comprised of a plurality of interconnecting flexible rods.
3. A support stand as claimed in claim 2 wherein each flexible support rod is comprised of either two or three interconnecting flexible rods.
4. A support stand as claimed in any one of the preceding claims wherein the transverse connecting member is provided with suction cups.
5. A support stand as claimed in any one of the preceding claims wherein the accepting means for the flexible support rod is a tube adapted to receive the said rod.



6. A support stand as claimed in any one of the preceding claims, wherein the flexible rods are straight when not in use in supporting said banner.
7. A support stand for a banner, substantially as described herein with reference to the accompanying drawings.
8. A method of supporting a banner in a free standing and substantially upright orientation comprising attaching said banner to a support stand as claimed in any one of the preceding claims.
9. A support stand and banner, when assembled substantially as herein described with reference to the accompanying drawings.

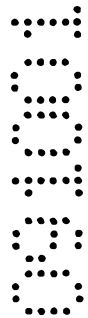
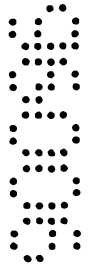

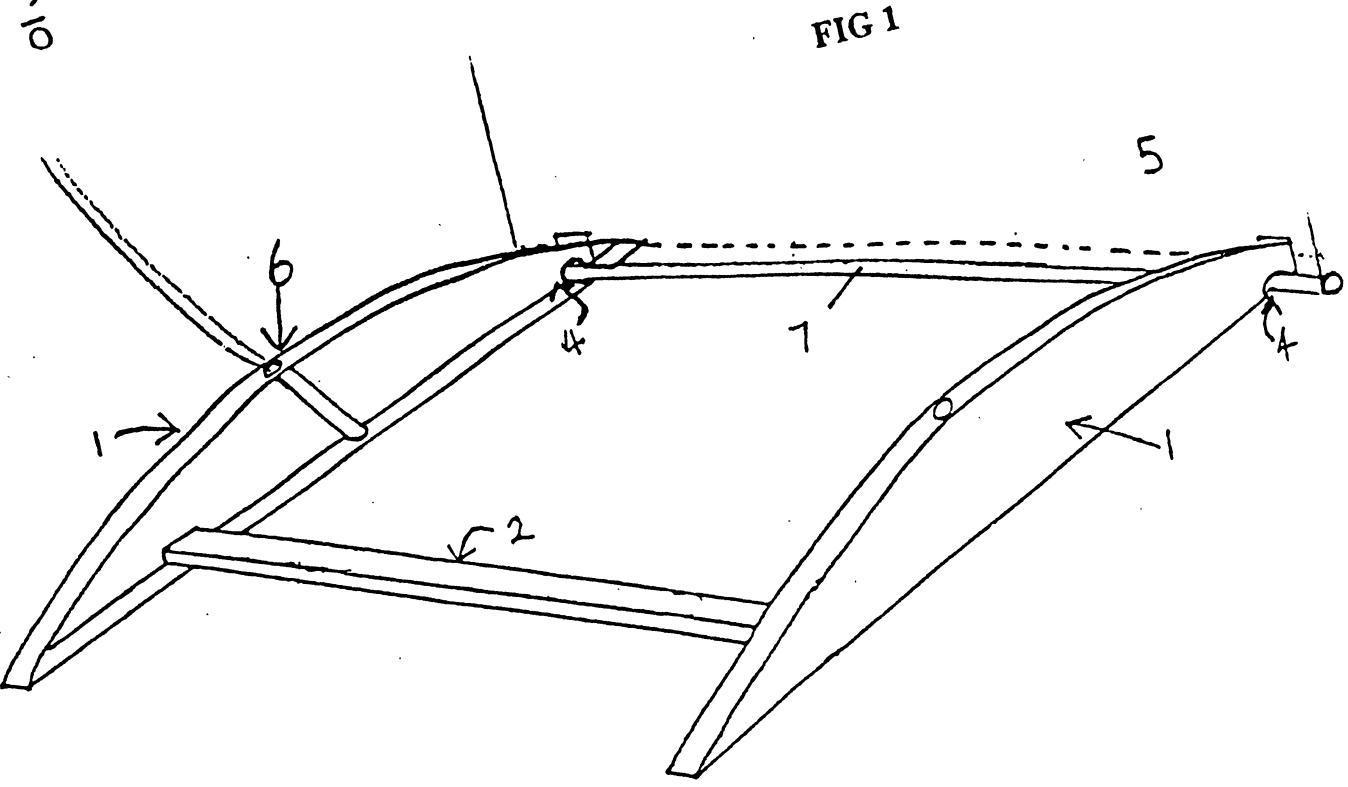

FIG 1

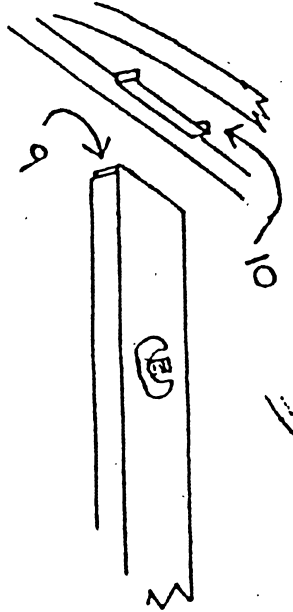

FIG 2

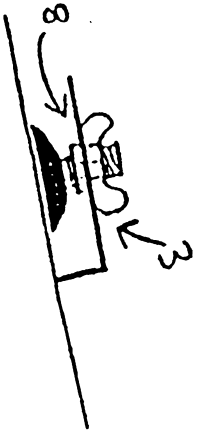

FIG 3

1/2

