

(19) **DANMARK**

(10) **DK/EP 2803258 T3**



Patent- og
Varemærkestyrelsen

(12) **Oversættelse af
europæisk patentskrift**

-
- (51) Int.Cl.: **A 01 D 87/12 (2006.01)** **A 01 D 85/00 (2006.01)** **A 01 D 90/08 (2006.01)**
- (45) Oversættelsen bekendtgjort den: **2018-05-22**
- (80) Dato for Den Europæiske Patentmyndigheds bekendtgørelse om meddelelse af patentet: **2018-03-14**
- (86) Europæisk ansøgning nr.: **13382180.1**
- (86) Europæisk indleveringsdag: **2013-05-15**
- (87) Den europæiske ansøgnings publiceringsdag: **2014-11-19**
- (84) Designerede stater: **AL AT BE BG CH CY CZ DE DK EE ES FI FR GB GR HR HU IE IS IT LI LT LU LV MC MK MT NL NO PL PT RO RS SE SI SK SM TR**
- (73) Patenthaver: **Arcusin S.A., Pol. Ind. Pla d'Urgell , Av. Merlet, 8, 25245 Vila-Sana, Spanien**
- (72) Opfinder: **Cusine Barber, Manuel, ARCUSIN, S. A., Pol. Ind. Pla d'Urgell, Av. Merlet, 8, 25245 VILA-SANA, Spanien**
- (74) Fuldmægtig i Danmark: **Zacco Denmark A/S, Arne Jacobsens Allé 15, 2300 København S, Danmark**
- (54) Benævnelse: **Maskine til stabling af baller**
- (56) Fremdragne publikationer:
DE-A1- 2 331 868
DE-A1- 3 924 490
FR-A2- 2 319 554
GB-A- 1 504 888
US-A1- 2006 245 880

DESCRIPTION

Background of the invention

[0001] Accumulators that group hay bales to facilitate handling or transport thereof from the field to a storage location are available in the market. However, most of these accumulators are destined for grouping small prismatic bales.

[0002] In order to group large prismatic bales, there are accumulators that comprise a horizontal platform whereon three bale packages are formed, which is then tilted to deposit and unload the three packages onto the ground. These accumulators have the drawback of being complicated to handle, as the horizontal platform requires a large amount of space.

[0003] Patent DE19954487 discloses a large prismatic bale accumulator having the advantage over the other accumulators in the market that it dispenses with the aforementioned horizontal platform and is capable of vertically stacking the bales by lifting them directly off the ground.

[0004] The accumulator of the aforementioned patent DE19954487 comprises a frame configured to be towed and positioned over a hay bale resting on the ground in a field. This frame includes a clamp for holding and vertically lifting the bale from a lower stacking position to an upper stacking position. Once the bale is disposed in this upper stacking position, the accumulator moves until the frame is positioned over a new bale, in such a manner that the bale suspended by the clamp can be deposited on top of the new bale so as to form a stack.

[0005] However, it has been proven that the accumulator of the aforementioned patent has several drawbacks. One of said drawbacks lies in the fact that it works at a very slow rate, as the accumulator must stop over an incoming bale long enough for the clamp's gripping arms to descend and grip the bale. Also, in many cases the tractor operator must have sufficient expertise to ensure that the bale entering the frame is centered with respect to the clamp's arms, as otherwise the bale itself will prevent the clamp from descending to the loading position. This results in a slower work pace, which negatively affects accumulator performance.

Description of the invention

[0006] The objective of the present invention is to resolve the aforementioned drawbacks by developing an accumulator for grouping small or large hay bales which has the following advantages.

[0007] In accordance with this objective, the present invention provides a hay bale accumulator that comprises a frame configured to be dragged and positioned over a hay bale

resting on the ground, said frame comprising means for holding and vertically lifting said bale off the ground to an upper stacking position, and is characterised in that said means for vertically lifting the bale include at least one pair of vertical slide carriages of said bale holding means, said carriages being disposed in opposition to each other on the sides of a bale holding compartment of said frame, said accumulator also comprising means for suspending said bale in said upper stacking position while said carriages move towards a lower loading position in the interior of said compartment to receive a new bale, the entrance of said compartment being susceptible of becoming free to receive said new bale while said slide carriages remain on standby.

[0008] The accumulator of the present invention has the advantage over the other accumulators in the state of the art that it allows vertical stacking of the bales, lifting them directly off the ground at a very fast work pace, without need to stop the accumulator.

[0009] In the accumulator of the present invention, the carriages that include the means for holding the bales are disposed in opposition to each other on the sides of a bale holding compartment awaiting an incoming bale. As a result, when the frame is disposed over a hay bale, the holding means act almost immediately, gripping the bale and moving it vertically to the upper stacking position where the bale is suspended.

[0010] Therefore, as opposed to the accumulator of patent application DE19954487, in the accumulator claimed the carriages do not have to ascend to an upper position to allow entry of a bale nor do they subsequently have to descend to a lower position in order to hold and lift the same bale, but rather said carriages can wait for a bale, without interfering with the entry thereof in the compartment.

[0011] Additionally, in the present invention the carriages can descend to the lower loading position in order to hold and lift the last incoming bale while the previously loaded bale remains suspended.

[0012] In the accumulator of patent DE19954487, this stacking process is not possible, as there are no means for suspending the bales and when the carriages are in a lower loading position, the carriages themselves will prevent the entry of a new bale in the compartment.

[0013] According to one embodiment, the bale holding means comprise at least two gripping arms joined in an articulated manner to each of said slide carriages, said arms being susceptible of being extended to come into contact with said bale when said bale enters said compartment.

[0014] The gripping arms have the peculiarity that they are retracted to free the entrance and are extended to come into contact with the bale when said bale enters the compartment.

[0015] These gripping arms are configured in the manner of clamps and can optionally include spikes that are introduced or driven into the bale to hold it.

[0016] According to the same embodiment, the means for suspending the bale in the upper stacking position comprise at least two grasping arms joined in an articulated manner to structures on the sides of the bale holding compartment of said frame, said arms being susceptible of being extended to grasp said bale when said bale is in the upper stacking position.

[0017] Also according to the same embodiment, said accumulator comprises at least one pair of slide rails of said carriages vertically disposed in opposition to each other on the structures on the sides of said compartment, said rails allowing said carriages to move from said lower loading position to said upper stacking position and vice versa.

[0018] Therefore, as opposed to the accumulators of the state of the art, the weight of the stack rests on the structures on the sides of the compartment. In the accumulator of DE19954487, the weight of the stack is cantilevered, making it more unstable.

[0019] Also, this configuration with lateral carriage slide rails has the advantage over the accumulator of DE19954487 that it considerably reduces total accumulator height, as the carriages can be disposed at a lower height without interfering with the entry of the bale.

[0020] Preferably, the accumulator comprises a rear stopper to hold the bales in the interior of said compartment while said accumulator is towed by a tractor and, advantageously, said rear stopper includes at least one door that is joined in an articulated manner to the exit of said compartment, said door being susceptible of being opened to release a stack of bales from the interior of said compartment while said accumulator is being towed by the tractor.

[0021] This rear stopper pushes the incoming bale to the interior of the compartment, dragging it along the ground long enough for the bale to be held by the carriage gripping arms. When the stack is unloaded, the door opens to release the load. Therefore, the stacking process can be carried out in a continuous manner without need to stop the tractor, thereby improving performance.

[0022] Preferably, the accumulator comprises a draw bar to join said frame to the drive train of said tractor in an articulated manner, said accumulator being susceptible of being misaligned with respect to the tractor to facilitate the entry of a bale in the interior of said compartment.

[0023] Advantageously, said frame comprises a structure disposed in a bridge-like manner between the structures on the sides of said compartment, said structure determining the upper limit of the entry to said compartment in a bridge-like manner.

[0024] Preferably, said accumulator comprises means for guiding the bales on entering the bale holding compartment of the frame.

[0025] According to one embodiment, said bale guiding means comprise a pair of guides

disposed horizontally on either side of said compartment and, optionally, at least a second guide that projects from the compartment to guide the bales to the entrance of the compartment while the accumulator is being towed by the tractor.

[0026] This second guide could be disposed, for example, on the draw bar that joins the frame to the tractor.

[0027] The aforementioned guides facilitate the entry and correct positioning of the bale in the interior of the compartment while the accumulator is being towed by the tractor, allowing a very fast work pace.

[0028] The accumulator of the present invention is specially designed to collect and vertically stack large hay bales directly from the field or meadow where the bales are resting. As a result, the accumulator dispenses with horizontal or intermediate loading platforms, due to which it is very simple and easy to operate. In addition, the vertical stacking facilitates subsequent loading onto trailers or trucks.

[0029] Additionally, this accumulator works at a very fast pace in the field, as the stacks are formed and unloaded continuously while being towed and the frame being positioned consecutively over the hay bales resting in the field.

[0030] Further, the guides that guide the bales allow the loading operation to always be carried out ensuring the correct position of the bale package and, thus, stack stability.

Brief description of the drawings

[0031] In order to better understand the foregoing, drawings have been attached where an embodiment has been represented schematically and by way of non-limiting example:

Figure 1 shows an elevational view of one side of the accumulator.

Figure 2 shows a top plan view of the accumulator of figure 1.

Figure 3 shows a perspective view of the rear of the accumulator of figure 1.

Figures 4 to 8 show various perspective and elevational views of the loading cycle of a stack formed by the accumulator of figure 1.

Figure 9 shows a perspective view of the accumulator during unloading of a stack.

Description of a preferred embodiment

[0032] Following is a description of the accumulator (1) of the present invention, making reference to the foregoing figures.

[0033] The accumulator (1) claimed includes a frame (2) configured to be towed and positioned over a hay bale (3) resting directly on the ground in a field.

[0034] The frame (2) includes a pair of carriage (5a, 5b) slide guides (4) vertically disposed in opposition to each other on the sides of a bale (3) holding compartment (6) of the frame (2). In the embodiment described, the guides (4) are disposed in opposition to structures on the sides (17) of the compartment (6) that rest on the drive train of the wheels (7). As can be observed in figure 2, these wheels (7) and the carriages (5a, 5b) are disposed centered in an intermediate position that facilitates the load balancing of the structures (17) on the sides of the frame (2).

[0035] The same frame (2) comprises a structure (8) disposed in a bridge-like manner between the structures (17) on the sides of the compartment (6). This structure (8) defines the upper limit of the entrance of the bale (3) holding compartment (6).

[0036] The frame (2) is joined to the drive train of a tractor in an articulated manner by means of a draw bar (9). In this manner, the operator can misalign the accumulator (1) with respect to the tractor in a working position that facilitates the entry of the bales (3) in the interior of the compartment (6).

[0037] The sides of the bale (3) holding compartment (6) of the frame (2) include horizontally disposed guides (10) for positioning the bales (3). As can be observed in the top plan view of figure 2, in addition to the guides (10) of the interior of the compartment (6), the accumulator (1) includes a second guide (11) that projects from the compartment (6) to guide the bales (2) towards the entrance while the accumulator (1) is being towed by the tractor.

[0038] A swinging door (12) has been envisaged at the rear of the compartment (6) of the frame (2) which acts as a rear stopper when closed in order to grasp the bales (3) in the interior of the compartment (6) while the accumulator (1) is being towed by the tractor.

[0039] This door (12) is joined in an articulated manner to the exit of the compartment (6) and is actuated by a fluid dynamic cylinder to allow the exit and unloading of the bales (3) that form the stack (13).

[0040] The bale (3) holding means are joined to the slide carriages (5a, 5b). In the embodiment being described, these holding means are configured by two gripping arms (14) which can move simultaneously on actuating the carriages (5a, 5b) in order to hold and lift a bale (3) in the interior of the compartment (6). The carriages (5a, 5b) are actuated by means of a pair of fluid dynamic cylinders (15) mounted on the slide rails (4) of the carriages (5a, 5b). The gripping arms (14) are joined to their respective carriage (5a, 5b) in an articulated manner in such a manner that they are susceptible of being extended to come into contact with a bale

(3) when said bale (3) is in the interior of the compartment (6) (see figure 6).

[0041] As already mentioned in the description of the invention, the accumulator (1) comprises means for suspending a bale (3) in the upper stacking position while the carriages (5a, 5b) move towards a lower stacking position to receive a new bale (3).

[0042] These suspension means are configured by two grasping arms (16) joined in an articulated manner to the structures on the sides (17) of the frame (2) and are susceptible of being extended to hold a bale (3) in the aforementioned upper stacking position (see figure 7).

[0043] In the embodiment being described, both the gripping arms (14) and the grasping arms (16) are configured in the manner of a clamp. However, these arms (14, 16) can be configured, for example, in the manner of spikes or other type of appropriate means for holding the bales (3).

[0044] Following is a description of the operation of the accumulator (1), making reference to figures 4 to 9, which describe a loading and unloading cycle of the accumulator (1).

[0045] The accumulator (1) moves along the road completely aligned with the tractor. On arriving at the field, the frame (2) moves by means of the draw bar (9) to adopt a working position wherein it becomes misaligned in order to facilitate the entry of the bales (3) in the interior of the compartment (6) of the frame (2).

[0046] As the accumulator (1) moves forward and encounters the first bale (3a) which is resting on the ground in the field, the guides (10, 11) guide the bale (3a) to position it in the interior of the compartment (6), until stopping against the swinging door (12) located at the rear of the compartment (6).

[0047] While the accumulator (1) moves forward, the bale (3a) is grasped momentarily in the interior of the compartment (6) by the door (12) which acts as a rear stopper. Simultaneously, the gripping arms (14) are vertically extended so that they come into contact with the bale (3a) to hold it. Next, the carriages (5a, 5b) are simultaneously actuated to vertically move the gripping arms (14) in order to lift the bale (3a) to a predetermined upper stacking position. In this position, the grasping arms (14) can descend to the lower loading position to await a new bale (3b).

[0048] Next, without stopping the accumulator (1), the frame (2) moves over a second bale (3b) that enters the compartment (6) and is positioned beneath the first bale (3a), which is suspended in the upper stacking position.

[0049] Figure (7) shows this upper stacking position wherein the first bale (3a) is suspended by the grasping arms (16) of the structures on the sides (17) of the frame (2), while the gripping arms (14) hold a new bale (3b) disposed at the lower loading position of the compartment (6).

[0050] Once the second bale (3b) is held in place, the carriages (5a, 5b) ascend to approximate the second bale (3b) to the first bale (3a) and form a stack (13). Next, the grasping arms (16) are extended to deposit the first bale (3a) on top of the second bale (3b). In this position, the first bale (3a) rests on the second bale (3b), forming a stack (13) so that the arms (14) of the carriages (5a, 5b) can descend to the lower loading position (see figure 8).

[0051] At this point, without stopping the accumulator (1), the operator may choose between releasing the stack (13) of the two bales (3a, 3b) and opening the door (12) or starting a new loading cycle, collecting a third bale (3c) located inside the compartment (6). In this second case, the operator must move the carriages (5a, 5b) to the upper position, raising the stack (13) and then actuating the grasping arms (16) to hold the stack (13) and release the gripping arms (14) so that these can descend to the lower position to deliver a new bale (3c).

[0052] Figure 9 shows the unloading of a stack (13) of three bales (3a, 3b, 3c) formed in the interior of the compartment (6). When the accumulator (1) is in the forward position and the bale (3) package of the stack (13) is stopped on the ground, the load is automatically evacuated.

[0053] In order to unload the stack (13) on a nearby path or in a specific loading area, the accumulator (1) is transferred to the desired unloading place with the load suspended in its interior.

[0054] Despite the fact that reference has been made to a specific embodiment of the invention, it is evident to a person skilled in the art that the described accumulator (1) is susceptible of numerous variations and modifications, and that all the aforementioned details may be substituted for other, technically equivalent ones without detracting from the scope of protection defined by the attached claims.

REFERENCES CITED IN THE DESCRIPTION

This list of references cited by the applicant is for the reader's convenience only. It does not form part of the European patent document. Even though great care has been taken in compiling the references, errors or omissions cannot be excluded and the EPO disclaims all liability in this regard.

Patent documents cited in the description

- [DE19954487](#) [\[0003\]](#) [\[0004\]](#) [\[0010\]](#) [\[0012\]](#) [\[0018\]](#) [\[0019\]](#)

Patentkrav

- 5
10
15
- 1.** Høballe (3) -samler (1) omfattende en ramme (2), der er udformet til at blive trukket og positioneret over en høballe (3), der ligger på jorden, hvor rammen (2, 17) omfatter midler til at holde og vertikalt løfte en balle (3a) fra jorden til en øvre stablingsposition, **kendetegnet ved, at** midlerne (5, 14, 15) til vertikalt at løfte ballen (3a) indbefatter mindst et par vertikale glideslæder (5a, 5b) af balleholdemidlerne (14), hvor slæderne (5a, 5b) er anbragt modsat hinanden på siderne af et balle (3) -holderum (6), hvor balleholdemidlerne omfatter mindst to gribearme (14), der hver især er ledforbundet med hver af glideslæderne (5a), hvor gribearmene (14) kan forlænges til at komme i kontakt med ballen (3), når ballen (3) kommer ind i rummets (6) indre, hvor samleren også omfatter midler (16) til ophængning af ballen (3a) i den øvre stablingsposition i rummets (6) indre, mens slæderne (5a, 5b) bevæger sig mod en nedre læsseposition til modtagelse af en ny balle (3b), hvor gribearmene kan trækkes tilbage til frigørelse af indgangen til rummet (6) til modtagelse af en ny balle (3b), mens glideslæderne (5a, 5b) forbliver klar til indsats i den nedre læsseposition.
- 20
- 2.** Samler (1) ifølge krav 1, hvor midlerne til ophængning af ballen i den øvre stablingsposition omfatter mindst to gribearme (16), der er ledforbundet med strukturer (8) på siderne af rammens (2, 17) balle (3) -modtagelsesrum (6), hvor armene (16) kan forlænges til at komme i kontakt med ballen (3), når ballen (3) er i den øvre stablingsposition.
- 25
- 3.** Samler (1) ifølge et af de foregående krav, omfattende mindst et par glide-skiner (4) af slæderne (5a, 5b), der er anbragt vertikalt modsat hinanden på strukturerne på siderne (17) af rummet (6), hvor skinnerne (4) muliggør, at slæderne (5a, 5b) kan bevæge sig fra den nedre læsseposition til den øvre stablingsposition og omvendt.
- 30
- 4.** Samler (1) ifølge et af kravene 1 til 3, omfattende en bagstopper (12) til at gribe ballerne (3) i rummets (6) indre, mens samleren (1) trækkes af en traktor.

5. Samler (1) ifølge krav 4, hvor bagstopperen indbefatter mindst en dør (12), der er ledforbundet med udgangen af rummet (6), hvor døren (12) kan åbnes til frigivelse af en stabel (13) baller (3a, 3b) fra rummets (6) indre, mens samleren (1) trækkes af traktoren.

5

6. Samler (1) ifølge et af kravene 1 til 5, omfattende en trækstang (9) til at ledforbinde rammen (2) med traktorens drivanordning, hvor samleren (1) kan justeres skævt i forhold til traktoren for at muliggøre indføring af en balle (3) i rummets (6) indre.

10

7. Samler (1) ifølge et af kravene 3 til 6, hvor rammen (2, 17) omfatter en struktur (8), der er anbragt på en bro lignende måde mellem strukturerne på siderne (17) af rummet (6), hvor strukturen (8) bestemmer rummets (6) øvre indgangsgrænse på en bro lignende måde.

15

8. Samler (1) ifølge et af kravene 1 til 7, omfattende midler (10, 11) til føring af ballerne (3) til rummets (6) indgang.

20

9. Samler (1) ifølge krav 8, hvor midlerne til føring af ballerne omfatter et par føringer (10), der er anbragt horisontalt på hver side af rummet (6).

10. Samler (1) ifølge krav 8, hvor midlerne til føring af ballerne omfatter mindst en føring (11), der rager frem fra rummet (6) til føring af ballerne (3) mod indgangen, mens samleren (1) trækkes af traktoren.

25

DRAWINGS

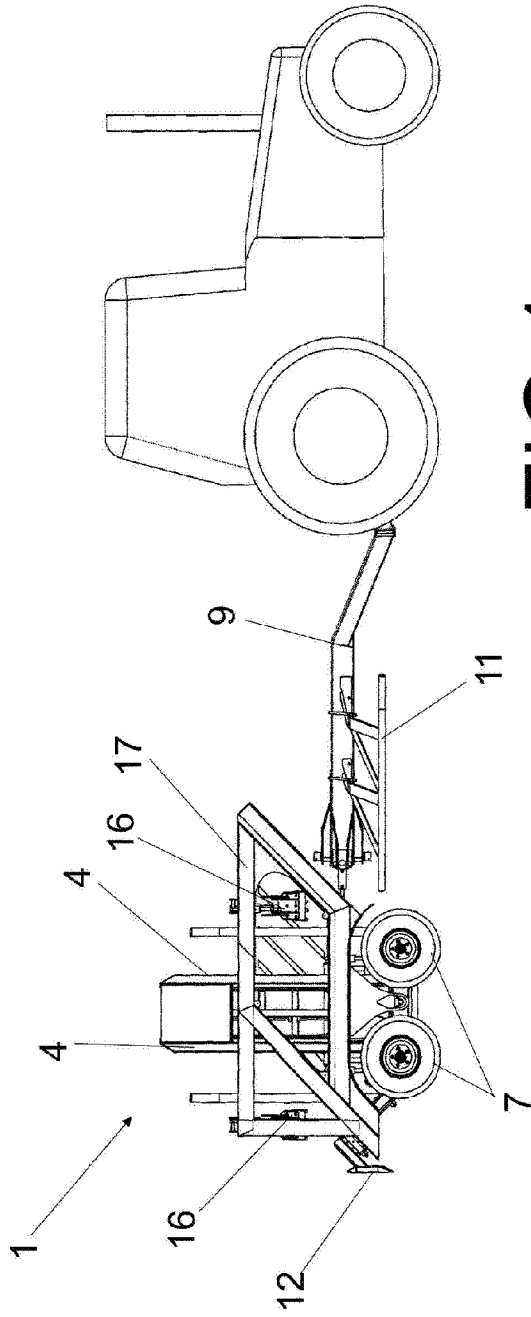

FIG.1

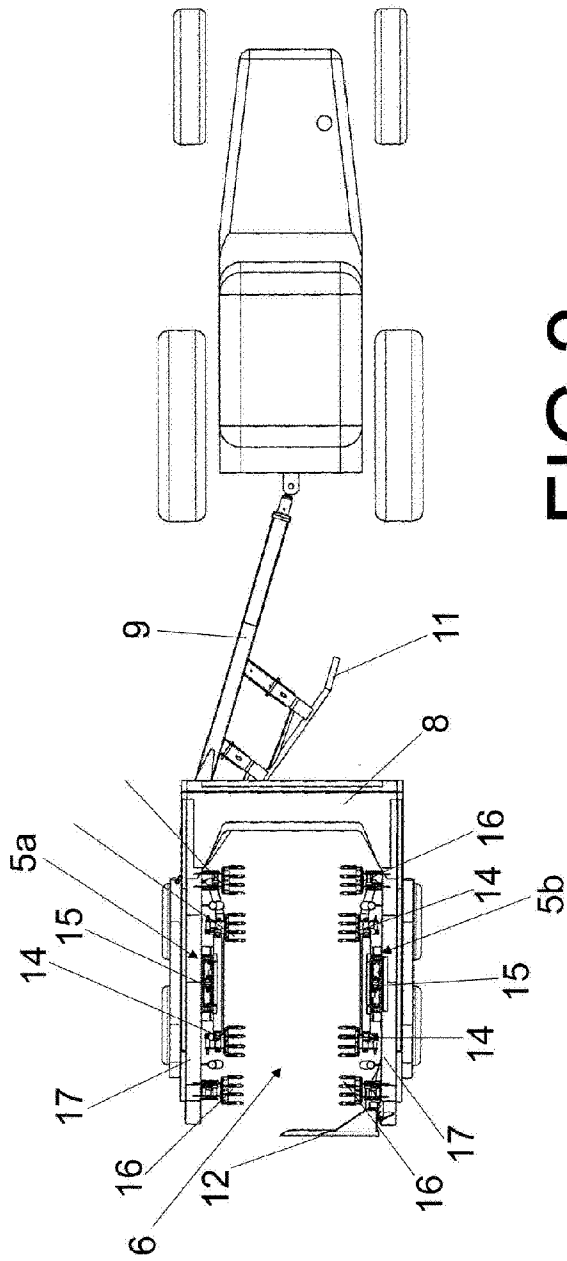

FIG.2

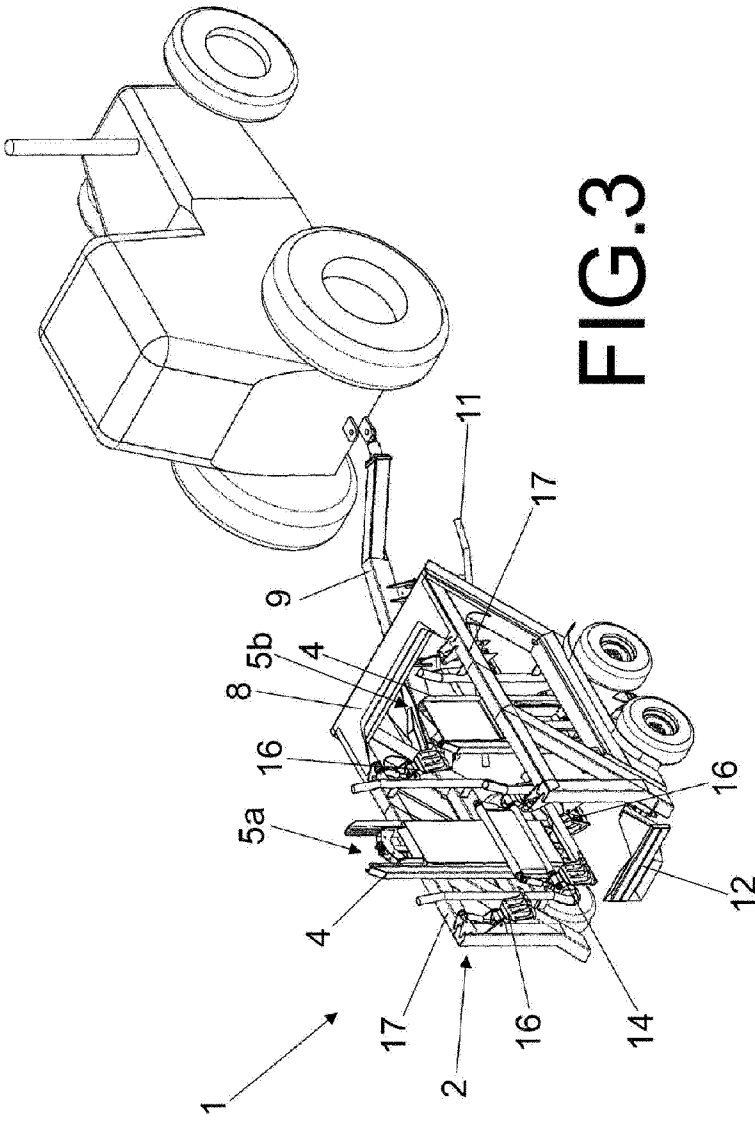

FIG. 3

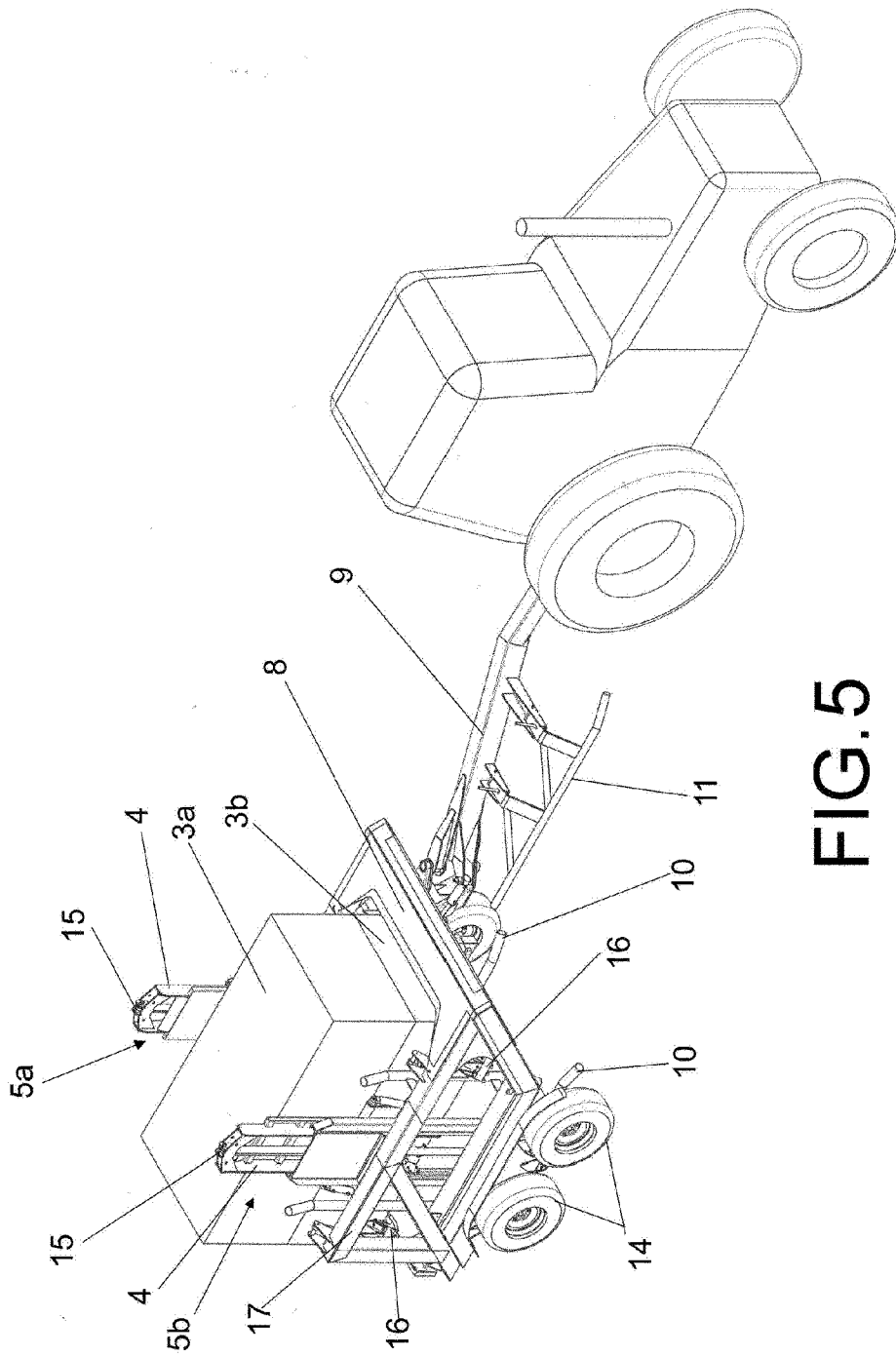

FIG.5

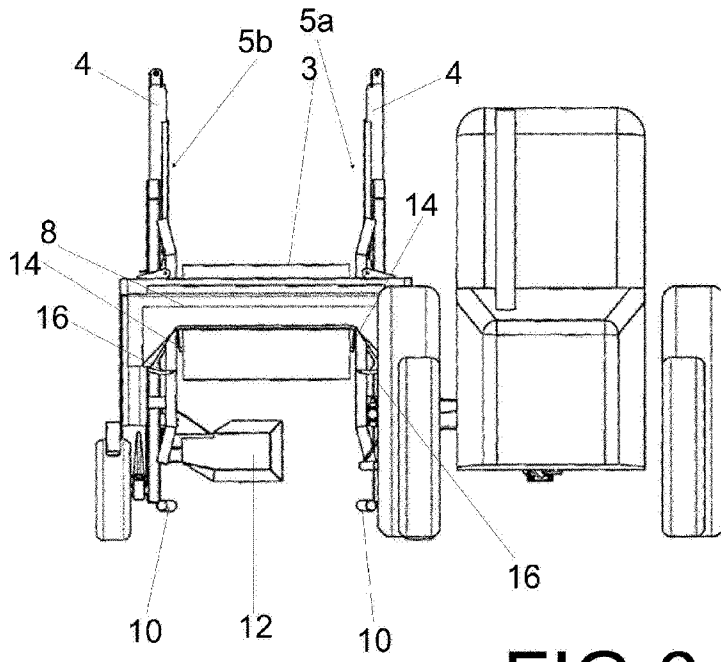
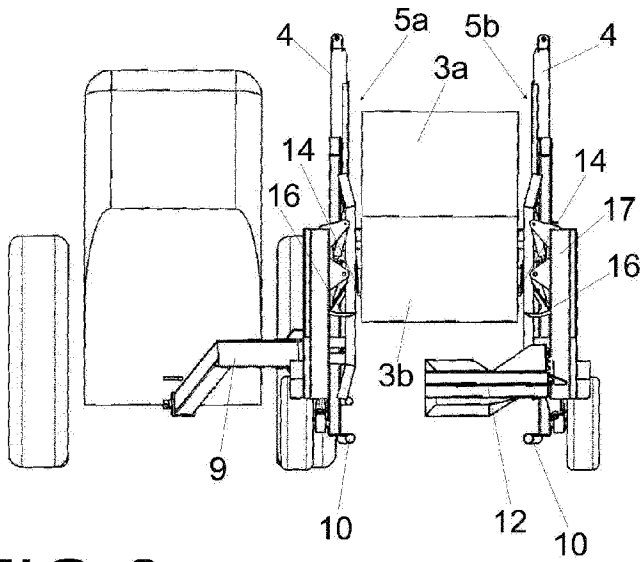
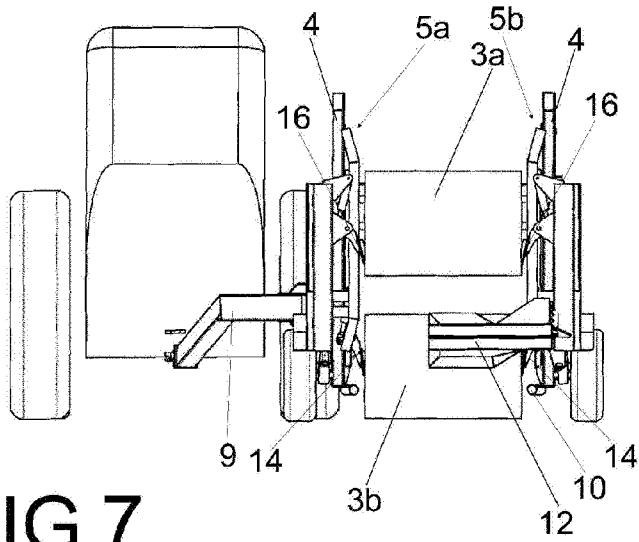

FIG. 6



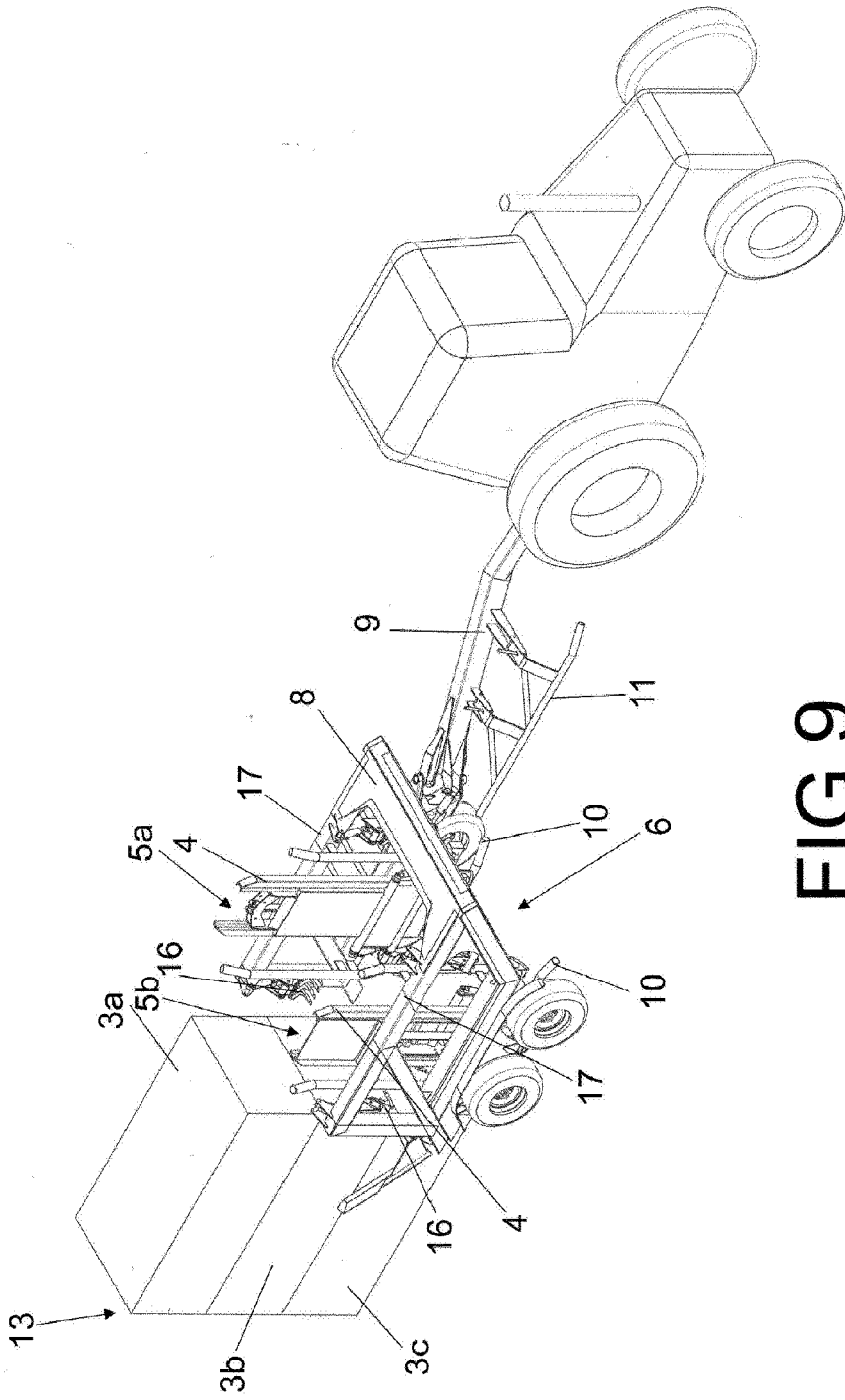

FIG.9