



- (51) International Patent Classification: *H04N 19/50* (2014.01)
- (21) International Application Number: PCT/CN2014/091140
- (22) International Filing Date: 14 November 2014 (14.11.2014)
- (25) Filing Language: English
- (26) Publication Language: English
- (30) Priority Data: 61/904,068 14 November 2013 (14.11.2013) US
- (71) Applicant (for all designated States except US): **MEDI-ATEK SINGAPORE PTE. LTD.** [SG/SG]; #03-01 Solaris, No.1 Fusionopolis Walk, Singapore 138628 (SG).
- (72) Inventors; and
- (71) Applicants (for US only): **LIU, Shan** [US/US]; 1155 Nevada Ave., San Jose, California 95125 (US). **XU, Xiaozhong** [CN/US]; 38457 Crosspointe Cmn Fremont, California 94536 (US).
- (74) Agent: **BEIJING SANYOU INTELLECTUAL PROPERTY AGENCY LTD.**; 16th Fl., Block A, Corporate Square, No.35 Jinrong Street, Beijing 100033 (CN).
- (81) Designated States (unless otherwise indicated, for every kind of national protection available): AE, AG, AL, AM, AO, AT, AU, AZ, BA, BB, BG, BH, BN, BR, BW, BY, BZ, CA, CH, CL, CN, CO, CR, CU, CZ, DE, DK, DM, DO, DZ, EC, EE, EG, ES, FI, GB, GD, GE, GH, GM, GT, HN, HR, HU, ID, IL, IN, IR, IS, JP, KE, KG, KN, KP, KR, KZ, LA, LC, LK, LR, LS, LU, LY, MA, MD, ME, MG, MK, MN, MW, MX, MY, MZ, NA, NG, NI, NO, NZ, OM, PA, PE, PG, PH, PL, PT, QA, RO, RS, RU, RW, SA, SC, SD, SE, SG, SK, SL, SM, ST, SV, SY, TH, TJ, TM, TN, TR, TT, TZ, UA, UG, US, UZ, VC, VN, ZA, ZM, ZW.
- (84) Designated States (unless otherwise indicated, for every kind of regional protection available): ARIPO (BW, GH, GM, KE, LR, LS, MW, MZ, NA, RW, SD, SL, ST, SZ, TZ, UG, ZM, ZW), Eurasian (AM, AZ, BY, KG, KZ, RU, TJ, TM), European (AL, AT, BE, BG, CH, CY, CZ, DE, DK, EE, ES, FI, FR, GB, GR, HR, HU, IE, IS, IT, LT, LU, LV, MC, MK, MT, NL, NO, PL, PT, RO, RS, SE, SI, SK,

[Continued on next page]

(54) Title: METHOD OF VIDEO CODING USING PREDICTION BASED ON INTRA PICTURE BLOCK COPY

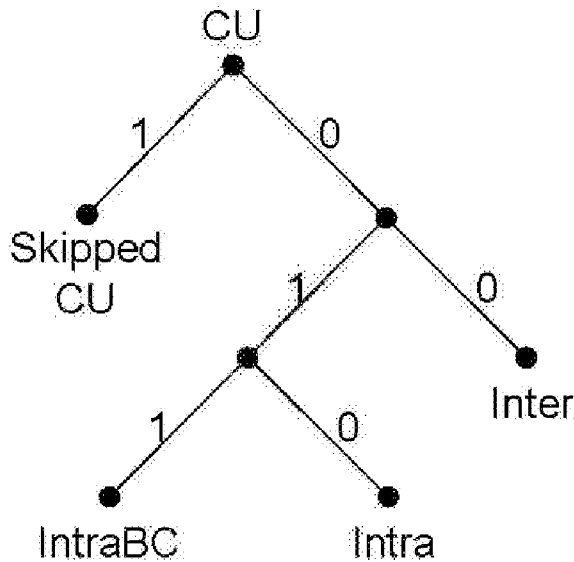

Fig.4B

(57) Abstract: A method of signaling of coding modes including an IntraBC mode (Intra-block copy mode) to improve the coding efficiency is disclosed. The embodiment takes into consideration the facts that Inter prediction is more common in Inter slices than IntraBC prediction. In another embodiment, a binary sub-tree is disclosed that includes all the partition modes associated with IntraBC mode and the binary sub-tree consists of only said all members of the partition mode group.



SM, TR), OAPI (BF, BJ, CF, CG, CI, CM, GA, GN, GQ, GW, KM, ML, MR, NE, SN, TD, TG). **Published:**

— *with international search report (Art. 21(3))*

Declarations under Rule 4.17:

- *as to the applicant's entitlement to claim the priority of the earlier application (Rule 4.17(iii))*

METHOD OF VIDEO CODING USING PREDICTION **BASED ON INTRA PICTURE BLOCK COPY**

CROSS REFERENCE TO RELATED APPLICATIONS

[0001] The present invention claims priority to U.S. Provisional Patent
5 Application, Serial No. 61/904,068, filed on November 14, 2013, entitled “Methods
and apparatus for intra picture block copy in video compression”. The U.S.
Provisional Patent Application is hereby incorporated by reference in its entirety.

TECHNICAL FIELD

[0002] The present invention relates to video coding using Intra-block copy
10 (IntraBC) mode. In particular, the present invention relates to techniques to improve
the performance or simplify the processing of the Intra-block copy (IntraBC) coding
mode for screen content coding or video coding.

BACKGROUND

[0003] In the current development of range extension (RExt) or screen content
15 coding for High Efficiency Video Coding (HEVC) standard, some tools have been
adopted due to their improvements in coding efficiency for screen contents. For Intra
blocks, Intra prediction according to the conventional approach is performed using
prediction based on reconstructed pixels from neighboring blocks. Intra prediction
may select an Intra Mode from a set of Intra Modes, which include a vertical mode,
20 horizontal mode and various angular prediction modes. For HEVC Range Extension
and screen content coding, a new Intra coding mode, named Intra-block copy
(IntraBC) has been used. The IntraBC technique that was originally proposed by
Budagavi in *AHG8: Video coding using Intra motion compensation*, Joint
Collaborative Team on Video Coding (JCT-VC) of ITU-T SG 16 WP 3 and ISO/IEC
25 JTC 1/SC 29/WG 11, 13th Meeting: Incheon, KR, 18–26 Apr. 2013, Document:
JCTVC-M0350 (hereinafter JCTVC-M0350). An example according to JCTVC-
M0350 is shown in Fig. 1, where a current coding unit (CU, 110) is coded using Intra

MC (motion compensation). The prediction block (120) is located from the current CU and a displacement vector (112). In this example, the search area is limited to the current CTU (coding tree unit), the left CTU and the left-left CTU. The prediction block is obtained from the already reconstructed region. Then, the displacement vector, also named motion vector (MV), and residual for the current CU are coded. It is well known that the HEVC adopts CTU and CU block structure as basic units for coding video data. Each picture is divided into CTUs and each CTU is reclusively divided into CUs. During prediction phase, each CU may be divided into multiple blocks, named *prediction units* (PUs) for performing prediction process. After prediction residue is formed for each CU, the residue associated with each CU is divided into multiple blocks, named *transform units* (TUs) to apply transform (such as discrete cosine transform (DCT)).

[0004] In JCTVC-M0350, the Intra MC is different from the motion compensation used for Inter prediction in at least the following areas:

- MVs are restricted to be 1-D for Intra MC (i.e., either horizontal or vertical) while Inter prediction uses 2-D motion estimation.
- Binarization is fixed length for Intra MC while Inter prediction uses exponential-Golomb.
- Intra MC introduces a new syntax element to signal whether the MV is horizontal or vertical.

[0005] Based on JCTVC-M0350, some modifications are disclosed by Pang, et al. in *Non-RCE3: Intra Motion Compensation with 2-D MVs*, Joint Collaborative Team on Video Coding (JCT-VC) of ITU-T SG 16 WP 3 and ISO/IEC JTC 1/SC 29/WG 11, 14th Meeting: Vienna, AT, 25 July – 2 Aug. 2013, Document: JCTVC-N0256 (hereinafter JCTVC- N0256). Firstly, the Intra MC is extended to support 2-D MVs, so that both MV components can be non-zero at the same time. This provides more flexibility to Intra MC than the original approach, where the MV is restricted to be strictly horizontal or vertical.

[0006] In JCTVC-N0256, two MV coding methods were disclosed:

- Method 1- *Motion vector prediction*. The left or above MV is selected as the MV predictor and the resulting motion vector difference (MVD) is coded. A flag is used to indicate whether the MVD is zero. When MVD is not zero, exponential-

Golomb codes of the 3rd order are used to code the remaining absolute level of the MVD. Another flag is used to code the sign.

- Method 2: *No Motion vector prediction*. The MV is coded using the exponential-Golomb codes that are used for MVD in HEVC.

5 [0007] Another difference disclosed in JCTVC-N0256 is that the 2-D Intra MC is further combined with the pipeline friendly approach:

1. No interpolation filters are used,
2. MV search area is restricted. Two cases are disclosed:
 - a. Search area is the current CTU and the left CTU or
 - 10 b. Search area is the current CTU and the rightmost 4 column samples of the left CTU.

[0008] Among the proposed methods in JCTVC-N0256, the 2-D Intra MC, the removal of interpolation filters, and the search area constraint to the current CTU and the left CTU have been adopted in a new version draft standard. The CU level syntax

15 corresponding to JCTVC-N0256 has been incorporated in *High Efficiency Video Coding (HEVC) Range Extension text specification: Draft 4 (RExt Draft 4)*, Flynn, et al., Joint Collaborative Team on Video Coding (JCT-VC) of ITU-T SG 16 WP 3 and ISO/IEC JTC 1/SC 29/WG 11, 14th Meeting: Vienna, AT, 25 July – 2 Aug. 2013, Document: JCTVC-N1005. The CU level syntax adopted in RExt Draft 4 is shown in

20 Table 1.

Table 1.

	Descriptor	Note
coding_unit(x0, y0, log2CbSize) {		
if(transquant_bypass_enabled_flag)		
cu_transquant_bypass_flag	ae(v)	
if(slice_type != I)		
cu_skip_flag[x0][y0]	ae(v)	
nCbS = (1 << log2CbSize)		
if(cu_skip_flag[x0][y0])		
prediction_unit(x0, y0, nCbS, nCbS)		
else {		
if(intra_block_copy_enabled_flag)		(1-1)
intra_bc_flag[x0][y0]	ae(v)	
if(!intra_bc_flag[x0][y0]) {		(1-2)
if(slice_type != I)		(1-3)
pred_mode_flag	ae(v)	
if(CuPredMode[x0][y0] != MODE_INTRA log2CbSize == MinCbLog2SizeY)		(1-4)
part_mode	ae(v)	
}		
.....		

[0009] As shown in Table 1, a test “if(intra_block_copy_enabled_flag)” is performed as indicated by Note (1-1). The IntraBC flag (i.e., **intra_bc_flag**[x0][y0]) is incorporated if Intra block copy is enabled as indicated by intra_block_copy_enabled_flag. Syntax element **intra_bc_flag** indicates whether the associated block is coded in the IntraBC mode. Whether the current block is coded in Non-Intra block copy mode (i.e., if(!intra_bc_flag[x0][y0]) is checked as indicated by Note (1-2), and **pred_mode_flag** and **part_mode** may be incorporated according to the tests in Notes (1-3) and (1-4) if the block is not coded in the Intra block copy mode. Syntax element **pred_mode_flag** equal to 0 specifies that the current coding unit is coded in Inter prediction mode. **pred_mode_flag** equal to 1 specifies that the current coding unit is coded in Intra prediction mode. Syntax element **part_mode** specifies partitioning mode of the current coding unit.

[0010] Another variation of IntraBC method, named *Line-based Intra Block Copy* has been disclosed by Chen, et al., in *AHG8: Line-based Intra Block Copy*, Joint Collaborative Team on Video Coding (JCT-VC) of ITU-T SG 16 WP 3 and ISO/IEC JTC 1/SC 29/WG 11, JCTVC-O0205, 15th Meeting: Geneva, CH, 23 Oct. – 1 Nov. 2013, Document: JCTVC-O0205 (hereinafter JCTVC-O0205). Fig. 2A and Fig. 2B illustrate examples of line-based IntraBC method as disclosed in JCTVC-O0205, where a $2N \times 2N$ CU is split equally into multiple block partitions of size $M \times 2N$ (Fig. 2A) or $2N \times M$ (Fig. 2B). The partitioned blocks are termed as *lines* and M represents a power-of-2 integer and is smaller than $2N$. For each line, pixels are predicted in the same way as the original IntraBC except: (1) the block size is of $M \times 2N$ or $2N \times M$, and (2) blocks of size $M \times 2N$ and $2N \times M$ are restricted to only perform horizontal search and vertical search, respectively. Therefore, there are $2N/M$ Intra displacement vectors per CU needed to be searched and signaled. Fig. 2A illustrates an example of partitioning the CU horizontally into $M \times 2N$ lines or line blocks. Each line block may be predicted by a prediction line block in the left CTU that has been reconstructed already. The arrows in Fig. 2A represent the displacement vectors or motion vectors for corresponding line blocks. Fig. 2B illustrates an example of partitioning the CU vertically into $2N \times M$ lines or line blocks. Each line block may be predicted by a prediction line block in the CTU above the current CU that has been reconstructed already. The arrows in Fig. 2B represent the displacement vectors or motion vectors for corresponding line blocks. The improvement according to JCTVC-O0205 has shown significant BD-rate reduction over the conventional IntraBC approach. The

BD-rate is a well-known performance measurement in the field of video coding.

[0011] Table 2 illustrates an example of CU level syntax modification to support the line-based IntraBC as disclosed in JCTVC-O0205.

Table 2.

	Descriptor	Note
coding_unit(x0, y0, log2CbSize) {		
if(transquant_bypass_enabled_flag)		
cu_transquant_bypass_flag	ae(v)	
if(slice_type != I)		
cu_skip_flag [x0][y0]	ae(v)	
nCbS = (1 << log2CbSize)		
if(cu_skip_flag[x0][y0])		
prediction_unit(x0, y0, nCbS, nCbS)		
else {		
if(intra_block_copy_enabled_flag)		
intra_bc_flag [x0][y0]	ae(v)	
if(!intra_bc_flag[x0][y0]) {		
if(slice_type != I)		
pred_mode_flag	ae(v)	
if(CuPredMode[x0][y0] != MODE_INTRA log2CbSize == MinCbLog2SizeY)		
part_mode	ae(v)	
if(CuPredMode[x0][y0] == MODE_INTRA && PartMode != PART_NxN) {		(2-1)
ivm_flag	ae(v)	(2-2)
if(ivm_flag)		(2-3)
ivm_dir	ae(v)	(2-4)
}		
}		
}		
.....		

5 [0012] As shown in Table 2, a flag **ivm_flag** is incorporated in the syntax table as indicated by Note (2-2) if the prediction mode is MODE_INTRA and the partition mode is not PART_NxN as indicated by Note (2-1). **ivm_flag** equal to 1 specifies that line-based IntraBC is used for the current CU. **ivm_flag** equal to 0 specifies that line-based IntraBC is not used for the current CU. If the flag **ivm_flag** has a value of 1 as

10 indicated by Note (2-3), an addition flag **ivm_dir** is incorporated as indicated by Note (2-4). **ivm_dir** equal to 1 specifies that line-based IntraBC is along the vertical direction for the current CU. **ivm_dir** equal to 0 specifies that line-based IntraBC is along the horizontal direction for the current CU. According to JCTVC-O0205, the value of M (i.e., 1, 4, or N) is pre-set, i.e. hard coded without signaling.

15 [0013] The signaling orders of The Inter, Intra and IntraBC prediction modes according to the existing RExt for the Intra slice and the Inter slice are shown in Fig. 3A and Fig. 3B respectively.

SUMMARY

[0014] A method of signaling of coding modes including an IntraBC mode (Intra-block copy mode) according to the present invention is disclosed. This embodiment takes into consideration the facts that Inter prediction is more common in Inter slices than IntraBC prediction, and IntraBC prediction is currently treated as a special Intra prediction. Accordingly, a binary tree for signaling prediction modes of a coding unit (CU) is disclosed for improving the performance.

[0015] In another embodiment, multiple partition modes are allowed for IntraBC coding. A binary sub-tree according to this embodiment includes all the partition modes associated with IntraBC mode and the binary sub-tree consists of only said all members of the partition mode group. The partition mode group may consist of $2N \times 2N$, $2N \times M$, and $M \times 2N$ modes, and N and M are positive integers and M is not larger than N . In one example, the binary sub-tree for the $2N \times 2N$, $2N \times M$ mode and $M \times 2N$ modes corresponds to {1, 01, 00} respectively. In another example, the partition mode group consists of $2N \times 2N$ mode, $2N \times N$ mode, $N \times 2N$ mode, and $N \times N$ modes and the binary sub-tree for the $2N \times 2N$, $2N \times N$, $N \times 2N$ and $N \times N$ modes corresponds to {1, 01, 001, 000} respectively or {1, 001, 01, 000} respectively. The partition mode group may consist of $2N \times 2N$, $2N \times N$ and $N \times 2N$ modes when the CU is larger than 8×8 , and the binary sub-tree for the $2N \times 2N$, $2N \times N$ and $N \times 2N$ modes corresponds to {1, 01, 00} respectively or {1, 00, 01} respectively. The partition mode group may also consist of $2N \times 2N$, $2N \times N$, $N \times 2N$, $nL \times 2N$, $nR \times 2N$, $2N \times nU$ and $2N \times nD$ modes if the current coding unit is larger than 8×8 , and the binary sub-tree for the $2N \times 2N$, $2N \times N$, $N \times 2N$, $nL \times 2N$, $nR \times 2N$, $2N \times nU$ and $2N \times nD$ modes corresponds to {1, 011, 001, 0100, 0101, 0000, 0001} respectively or {1, 001, 011, 0000, 0001, 0100, 0101} respectively.

[0016] Various control syntax elements may be incorporated in a sequence level, a picture level or a slice level of the bitstream. For example, an enable flag may be used to indicate whether the partition mode group is allowed to include one or more asymmetric partition modes for a corresponding sequence, a corresponding picture or a corresponding slice. In another example, an enable flag may be used to indicate whether the partition mode group is allowed to include one or more non-square partition modes. In another example, an enable flag may be used to indicate whether

the partition mode group is allowed to include one or more multiple partition modes to partition the coding unit into more than two sub-blocks. In another example, an enable flag may be used to indicate a total number of sub-blocks that the coding unit is partitioned into the total number of sub-blocks.

5 BRIEF DESCRIPTION OF DRAWINGS

[0017] Fig. 1 illustrates an example of Intra motion compensation according to the Intra-block copy (IntraBC) mode, where a horizontal displacement vector is used.

[0018] Figs. 2A-B illustrate examples of line-based Intra-block copy (IntraBC) prediction, where a coding unit (CU) is partitioned into vertical or horizontal blocks,
10 named lines.

[0019] Figs. 3A-B illustrate binary trees of CU (coding unit) prediction modes according to the current Range Extension for High Efficiency Video Coding (RExt) for Intra and Inter slices.

[0020] Figs. 4A-B illustrate binary trees of CU (coding unit) prediction modes
15 according to an embodiment of the present invention for Intra and Inter slices.

[0021] Figs. 5A-B illustrate binary trees of CU (coding unit) prediction modes according to method disclosed in JCTVC-O0205 for Intra and Inter slices.

[0022] Figs. 6A-B illustrate binary trees of CU (coding unit) prediction modes under one sub-tree according to an embodiment of the present invention for Intra and
20 Inter slices.

DETAILED DESCRIPTION

[0023] In order to improve the performance or to reduce the complexity of Intra-block copy (IntraBC) prediction, the present invention discloses various improvements and simplified IntraBC prediction.

25 [0024] **First Embodiment.** In the binary tree associated with IntraBC prediction mode signaling shown in Fig. 3A and Fig. 3B, the binary coding tree may not be efficient for the following reasons. Inter prediction is sometimes more common in Inter slices than IntraBC prediction. However, the binary code for Inter mode in an Inter Slice as shown in Fig. 3B has a bit length of 3, which is a longest one. Also,
30 IntraBC prediction is currently treated as a special Intra prediction (i.e.

MODE_INTRA). Accordingly, the priority of Inter prediction and IntraBC prediction modes are modified according to the first embodiment of the present invention, as shown in Fig. 4A and Fig. 4B.

[0025] The binary coding tree for the Intra slice as shown in Fig. 4A remains to be the same. However, the binary coding tree for the Inter slice as shown in Fig. 4B has been modified to assign a codeword with code length of 2 to the Inter mode. Furthermore, the code lengths for IntraBC and Intra modes are 3. Table 3 illustrates an example of CU level syntax design to support the first embodiment.

Table 3.

coding_unit(x0, y0, log2CbSize) {	Descriptor	Note
if(transquant_bypass_enabled_flag)		
cu_transquant_bypass_flag	ae(v)	
if(slice_type != I)		
cu_skip_flag[x0][y0]	ae(v)	
nCbS = (1 << log2CbSize)		
if(cu_skip_flag[x0][y0])		
prediction_unit(x0, y0, nCbS, nCbS)		
else {		
if(intra_block_copy_enabled_flag)		(3-1)
intra_bc_flag[x0][y0]	ae(v)	
if(!intra_bc_flag[x0][y0]) {		(3-2)
if(slice_type != I)		
pred_mode_flag	ae(v)	
if(intra_block_copy_enabled_flag&&pred_mode_flag)		(3-3)
intra_bc_flag[x0][y0]	ae(v)	(3-4)
if(!intra_bc_flag[x0][y0] (CuPredMode[x0][y0] != MODE_INTRA log2CbSize == MinCbLog2SizeY))		(3-5)
part_mode	ae(v)	
}		
.....		

[0026] In Table 3, the syntax shown with slant lined background as indicated from Note (3-1) to Note (3-2) are deleted according to this embodiment. The IntraBC flag (i.e., **intra_bc_flag[x0][y0]**) is incorporated as indicated by Note (3-4) if the IntraBC mode enabled and **pred_mode_flag** has a value of 1 as indicated by Note (3-3). Furthermore, the test as indicated in Note (3-5) has also been modified by including “!**intra_bc_flag[x0][y0]**”.

[0027] **Second Embodiment.** In RExt Draft 4, when IntraBC mode is used and the prediction block size is not 2Nx2N, the prediction direction (i.e., vertical or horizontal) is actually signaled under the Intra prediction mode branch, as shown in Fig. 5A and Fig. 5B for the Intra slice and the Inter slice respectively. One drawback of this arrangement is that the IntraBC direction needs the Intra prediction partition

information to parse when the IntraBC prediction block size is not 2Nx2N. In other words, the parsing of IntraBC prediction partition modes regarding size and direction is dependent on Intra prediction partition mode. This dependency is not desired in hardware as well as software design and it is not necessary. In order to overcome this issue, the second embodiment of the present invention consolidates the IntraBC prediction mode signaling (i.e. 2Nx2N, 2NxM or Mx2N) into one branch, as shown in Fig. 6A and Fig. 6B for the Intra slice and the Inter slice respectively. As shown in Fig. 6A and Fig. 6B, the branches associated with the IntraBC prediction mode signaling (i.e. 2Nx2N, 2NxM or Mx2N) for both the Intra slice and the Inter slice are the same.

Table 4.

	Descriptor	Note
coding_unit(x0, y0, log2CbSize) {		
if(transquant_bypass_enabled_flag)		
cu_transquant_bypass_flag	ae(v)	
if(slice_type != I)		
cu_skip_flag[x0][y0]	ae(v)	
nCbS = (1 << log2CbSize)		
if(cu_skip_flag[x0][y0])		
prediction_unit(x0, y0, nCbS, nCbS)		
else {		
if(intra_block_copy_enabled_flag)		
intra_bc_flag[x0][y0]	ae(v)	
if(!intra_bc_flag[x0][y0] && slice_type != I)		(4-1)
if(slice_type != I)		(4-2)
pred_mode_flag	ae(v)	(4-3)
if(intra_bc_flag[x0][y0] CuPredMode[x0][y0] != MODE_INTRA log2CbSize == MinCbLog2SizeY)		(4-4)
part_mode	ae(v)	
}		
.....		

[0028] In Table 4, a test condition for non-IntraBC mode in a non-Intra slice is incorporated as indicated by Note (4-1). On the other hand, the test for a non-Intra slice in the conventional syntax design is removed as indicated by Note (4-2). The flag **pred_mode_flag** is incorporated as indicated by Note (4-3). An additional element “**intra_bc_flag[x0][y0]**” is added to the test as indicated by Note (4-4).

[0029] When **intra_bc_flag** equals to 1, the binarization of **part_mode** according to the second embodiment is shown in Table 5, M can be any positive integer that is a power of 2 and less than or equal to N. It is noted that the second embodiment may also be combined with the first embodiment.

Table 5.

part_mode	PartMode	Bin string
0	PART_2Nx2N	1
1	PART_2NxM	01
2	PART_Mx2N	00

[0030] *Third Embodiment.* In this embodiment, IntraBC prediction can also be applied to where an NxN partition is used, such as the NxN Intra prediction mode. Each NxN partition is independently predicted from a matching block within a picture, a slice, or a partial picture, or a partial slice, a region of the picture or slice, or the same CTU containing the current block. Accordingly, there are four Intra motion vectors per CU that need to be searched and signaled. Two examples for the binarization of **part_mode** according to this embodiment including 2NxM and Mx2N partition modes are shown in Tables 6 and 7, where M is set to N and **intra_bc_flag** is equal to 1.

Table 6.

part_mode	PartMode	Bin string
0	PART_2Nx2N	1
1	PART_2NxN	01
2	PART_Nx2N	001
3	PART_NxN	000

Table 7.

part_mode	PartMode	Bin string
0	PART_2Nx2N	1
1	PART_Nx2N	01
2	PART_2NxN	001
3	PART_NxN	000

[0031] In another example, the NxN partition for IntraBC is only allowed when the block is a SCU (smallest CU). Two examples of the binarization of **part_mode** are shown in Tables 8 and 9 with **intra_bc_flag** equal to 1. In Tables 8 and 9, the condition, “log2CbSize > MinCbLog2SizeY” implies that the current block size is greater than the smallest CU, and the condition, “log2CbSize == MinCbLog2SizeY” implies that the current block is an SCU.

Table 8.

part_mode	PartMode	Bin string	
		log2CbSize > MinCbLog2SizeY	log2CbSize == MinCbLog2SizeY
0	PART_2Nx2N	1	1
1	PART_2NxN	01	01
2	PART_Nx2N	00	001
3	PART_NxN		000

Table 9.

part_mode	PartMode	Bin string	
		log2CbSize > MinCbLog2SizeY	log2CbSize == MinCbLog2SizeY
0	PART_2Nx2N	1	1
1	PART_Nx2N	01	01
2	PART_2NxN	00	001
3	PART_NxN		000

[0032] In yet another example, the NxN partition is only allowed when the IntraBC CU size is greater than 8x8 (i.e., N > 4). The binarization of **part_mode** is shown in Tables 10 and 11 for **intra_bc_flag** equal to 1. The condition, “log2CbSize > MinCbLog2SizeY || log2CbSize == MinCbLog2SizeY && log2CbSize == 3” implies that the current block size is “8x8” or the current block is not an SCU. The condition, “log2CbSize == MinCbLog2SizeY && log2CbSize > 3” implies that “the current block is an SCU but the size is greater than 8x8”.

Table 10.

part_mode	PartMode	Bin string	
		log2CbSize > MinCbLog2SizeY log2CbSize == MinCbLog2SizeY && log2CbSize == 3	log2CbSize == MinCbLog2SizeY && log2CbSize > 3
0	PART_2Nx2N	1	1
1	PART_2NxN	01	01
2	PART_Nx2N	00	001
3	PART_NxN		000

10

Table 11.

part_mode	PartMode	Bin string	
		log2CbSize > MinCbLog2SizeY log2CbSize == MinCbLog2SizeY && log2CbSize == 3	log2CbSize == MinCbLog2SizeY && log2CbSize > 3
0	PART_2Nx2N	1	1
1	PART_Nx2N	01	01
2	PART_2Nx2N	00	001
3	PART_NxN		000

[0033] The same CU level syntax as shown in Table 4 can be used to support the exemplary binarization tables of **part_mode** as shown in Tables 6-12.

- 5 [0034] In another example, only NxN and 2Nx2N partition modes are allowed for IntraBC prediction. The binarization of **part_mode** for **intra_bc_flag** equal to 1 is shown in Table 12.

Table 12.

part_mode	PartMode	Bin string	
		log2CbSize > MinCbLog2SizeY	log2CbSize == MinCbLog2SizeY
0	PART_2Nx2N	-	1
1	PART_NxN	-	0

[0035] A CU level syntax design to support the binarization of Table 12 is shown in Table 13.

10

Table 13.

coding_unit(x0, y0, log2CbSize) {	Descriptor	Note
if(transquant_bypass_enabled_flag)		
cu_transquant_bypass_flag	ae(v)	
if(slice_type != I)		
cu_skip_flag [x0][y0]	ae(v)	
nCbS = (1 << log2CbSize)		
if(cu_skip_flag[x0][y0])		
prediction_unit(x0, y0, nCbS, nCbS)		
else {		
if(intra_block_copy_enabled_flag)		
intra_bc_flag [x0][y0]	ae(v)	
if(!intra_bc_flag[x0][y0] && slice_type != I)		(13-1)
if(slice_type != I)		(13-2)
pred_mode_flag	ae(v)	(13-3)
if(CuPredMode[x0][y0] != MODE_INTRA log2CbSize == MinCbLog2SizeY)		

part_mode	ae(v)	
}		
.....		

[0036] In Table 13, a test condition for non-IntraBC mode in a non-Intra slice is incorporated as indicated by Note (13-1). On the other hand, the test for a non-Intra slice in the conventional syntax design is removed as indicated by Note (13-2). The flag **pred_mode_flag** is incorporated as indicated by Note (13-3). The third embodiment can be combined with the first embodiment, the second embodiment or both.

[0037] *Fourth Embodiment.* In this embodiment, the IntraBC prediction is allowed to apply to $2N \times 2N$, $2N \times N$, $N \times 2N$, $2N \times M$ and $M \times 2N$ partitions. In one example, M can be any positive power-of-2 integer, but less than N (e.g., $M=N/2$). Examples of the binarization of **part_mode** with **intra_bc_flag** equal to 1 are shown in Tables 14 and 15. According to this embodiment, a $2N \times 2N$ IntraBC predicted CU is evenly split into $(2N/M)$ line-based partitions, either in vertical direction (i.e. $2N \times M$ mode) or in horizontal direction (i.e. $M \times 2N$ mode). Each $2N \times M$ or $M \times 2N$ partition is independently predicted from a matching block within a picture, a slice, or a partial picture, or a partial slice, a region of the picture or slice, or the same CTU containing the current block. Thus, there are $2N/M$ Intra motion vectors per CU that need to be searched and signaled. In the example that M is equal to $N/2$, when $2N \times (N/2)$ partition mode or $(N/2) \times 2N$ partition mode is selected, the $2N \times 2N$ IntraBC CU is evenly split into four $2N \times (N/2)$ or $(N/2) \times 2N$ line-based partitions, respectively. Each $2N \times (N/2)$ or $(N/2) \times 2N$ partition can be predicted from a different region within the search range in the current picture, with a distinct motion vector. The fourth embodiment can be combined with any combination of the first embodiment, the second embodiment and the third embodiment.

Table 14.

part_mode	PartMode	Bin string	
		$\log_2 \text{CbSize} > \text{MinCbLog}_2 \text{SizeY}$	$\log_2 \text{CbSize} == \text{MinCbLog}_2 \text{SizeY}$
0	PART_2Nx2N	1	1
1	PART_2NxN	011	01
2	PART_Nx2N	001	001
3	PART_NxN		000
4	PART_2NxM	010	

5	PART_Mx2N	000	
---	-----------	-----	--

Table 15.

part_mode	PartMode	Bin string	
		log2CbSize > MinCbLog2SizeY	log2CbSize == MinCbLog2SizeY
0	PART_2Nx2N	1	1
1	PART_Nx2N	011	01
2	PART_2NxN	001	001
3	PART_NxN		000
4	PART_Mx2N	010	
5	PART_2NxM	000	

[0038] **Fifth Embodiment.** In this embodiment, the IntraBC prediction is applied to asymmetric partitions. In one example, similar to the AMP (Asymmetric Motion Partition) in HEVC Inter prediction, partition modes PART_2Nx2N, PART_2NxN, PART_nLx2N and PART_nRx2N can be applied to a 2Nx2N IntraBC predicted CU. Furthermore, in another example, the definitions of PART_2Nx2N, PART_2NxN, PART_nLx2N and PART_nRx2N are the same as the definitions of those partition modes for HEVC inter prediction when AMP is enabled. In another example, nU, nD, nL and nR can be any positive integer that is power of 2 but less than N. Examples of the binarization of **part_mode** for **intra_bc_flag** equal to 1 are shown in Tables 16 and 17. In this case, each 2Nx2N, 2NxN, nLx2N or nRx2N partition is independently predicted from a matching block within a picture, a slice, or a partial picture, or a partial slice, a region of the picture or slice, or the same CTU containing the current block. Two Intra motion vectors per CU need to be searched and signaled. The fifth embodiment can be combined with any combination of the first embodiment, the second embodiment and the third embodiment.

Table 16.

part_mode	PartMode	Bin string	
		log2CbSize > MinCbLog2SizeY	log2CbSize == MinCbLog2SizeY
0	PART_2Nx2N	1	1
1	PART_2NxN	011	01
2	PART_Nx2N	001	001
3	PART_NxN		000

4	PART_2NxN _U	0100	
5	PART_2NxN _D	0101	
6	PART_nLx2N	0000	
7	PART_nRx2N	0001	

Table 17.

part_mode	PartMode	Bin string	
		log2CbSize > MinCbLog2SizeY	log2CbSize == MinCbLog2SizeY
0	PART_2Nx2N	1	1
1	PART_2NxN	011	01
2	PART_Nx2N	001	001
3	PART_NxN		000
4	PART_2NxN _U	0100	
5	PART_2NxN _D	0101	
6	PART_nLx2N	0000	
7	PART_nRx2N	0001	

[0039] *Sixth Embodiment.* In this embodiment, combinations of the above embodiments are disclosed. Also, high level syntax flags to enable or disable these methods in sequence level, picture level or slice level are disclosed. In one example, an SPS (sequence parameter set) flag (e.g., non_square_ibc_enabled_flag) is used to specify whether non-square IntraBC prediction partitions is allowed for this sequence. The syntax and semantics are illustrated in Table 18.

Table 18.

seq_parameter_set_rbsp() {	Descriptor	Note
.....	u(4)	
sps_extension1_flag	u(1)	
if(sps_extension1_flag) {		
transform_skip_rotation_enabled_flag	u(1)	
transform_skip_context_enabled_flag	u(1)	
intra_block_copy_enabled_flag	u(1)	
if(intra_block_copy_enabled_flag)		(18-1)
non_square_ibc_enabled_flag	u(1)	(18-2)
residual_dpcm_intra_enabled_flag	u(1)	
residual_dpcm_inter_enabled_flag	u(1)	
extended_precision_processing_flag	u(1)	
intra_smoothing_disabled_flag	u(1)	
sps_extension2_flag	u(1)	

}		
.....		
}		

[0040] As shown in Table 18, a new flag **non_square_ibc_enabled_flag** to indicate whether non-square IntraBC is enabled is incorporated as indicated by Note (18-2) if **intra_block_copy_enabled_flag** has a value of 1 as indicated by Note (18-1). **non_square_ibc_enabled_flag** equal to 1 specifies that non-square prediction partitions may be used in IntraBC predicted coding tree blocks. **non_square_ibc_enabled_flag** equal to 0 specifies that non-square prediction partitions cannot be used in IntraBC predicted coding tree blocks.

[0041] In another example, an SPS flag **asymmetric_ibc_enabled_flag** is used to specify whether asymmetric IntraBC prediction partitions may be applied to this sequence. An example of the syntax and semantics are shown in Table 19.

Table 19.

seq_parameter_set_rbsp() {	Descriptor	Note
.....	u(4)	
sps_extension1_flag	u(1)	
if(sps_extension1_flag) {		
transform_skip_rotation_enabled_flag	u(1)	
transform_skip_context_enabled_flag	u(1)	
intra_block_copy_enabled_flag	u(1)	
if(intra_block_copy_enabled_flag) {		(19-1)
non_square_ibc_enabled_flag	u(1)	(19-2)
if(non_square_ibc_enabled_flag)		(19-3)
asymmetric_ibc_enabled_flag	u(1)	(19-4)
}		
residual_dpcm_intra_enabled_flag	u(1)	
residual_dpcm_inter_enabled_flag	u(1)	
extended_precision_processing_flag	u(1)	
intra_smoothing_disabled_flag	u(1)	
sps_extension2_flag	u(1)	
}		
.....		
}		

[0042] As shown in Table 19, a new flag **non_square_ibc_enabled_flag** to indicate whether **non-square IntraBC** is enabled is incorporated as indicated by Note (19-2) if **intra_block_copy_enabled_flag** has a value of 1 as indicated by Note (19-1). Furthermore, a flag **asymmetric_ibc_enabled_flag** is incorporated as indicated by

Note (19-4) if **intra_block_copy_enabled_flag** has a value of 1 as indicated by Note (19-3). **asymmetric_ibc_enabled_flag** equal to 1 specifies that asymmetric prediction partitions (e.g., PART_2NxN_U, PART_2NxN_D, PART_nLx2N, or PART_nRx2N) may be used in IntraBC predicted coding tree blocks. **asymmetric_ibc_enabled_flag** equal to 0 specifies that asymmetric prediction partitions is disabled for the IntraBC predicted coding tree blocks.

[0043] In yet another example, a new SPS flag **multi_part_ibc_enabled_flag** is used to specify whether more than two prediction partitions may be applied to one IntraBC CU in this sequence. Two exemplary syntax and semantics are shown in Tables 20A and 20B.

Table 20A.

	Descriptor	Note
seq_parameter_set_rbsp() {		
.....	u(4)	
sps_extension1_flag	u(1)	
if(sps_extension1_flag) {		
transform_skip_rotation_enabled_flag	u(1)	
transform_skip_context_enabled_flag	u(1)	
intra_block_copy_enabled_flag	u(1)	
if(intra_block_copy_enabled_flag) {		(20-1)
non_square_ibc_enabled_flag	u(1)	(20-2)
if(non_square_ibc_enabled_flag)		(20-3)
multi_part_ibc_enabled_flag	u(1)	(20-4)
}		
residual_dpcm_intra_enabled_flag	u(1)	
residual_dpcm_inter_enabled_flag	u(1)	
extended_precision_processing_flag	u(1)	
intra_smoothing_disabled_flag	u(1)	
sps_extension2_flag	u(1)	
}		
.....		
}		

Table 20B.

	Descriptor	Note
seq_parameter_set_rbsp() {		
.....	u(4)	
sps_extension1_flag	u(1)	
if(sps_extension1_flag) {		
transform_skip_rotation_enabled_flag	u(1)	
transform_skip_context_enabled_flag	u(1)	
intra_block_copy_enabled_flag	u(1)	

if(intra_block_copy_enabled_flag)		(20-5)
multi_part_ibc_enabled_flag	u(1)	(20-6)
residual_dpcm_intra_enabled_flag	u(1)	
residual_dpcm_inter_enabled_flag	u(1)	
extended_precision_processing_flag	u(1)	
intra_smoothing_disabled_flag	u(1)	
sps_extension2_flag	u(1)	
}		
.....		
}		

[0044] The modifications of Table 20A from conventional syntax table are highlighted by Notes (20-1) and (20-4). As indicated by Note (20-2), **non_square_ibc_enabled_flag** is incorporated if **intra_block_copy_enabled_flag** has a value of 1 as indicated by Note (20-1). As indicated by Note (20-4),

5 **multi_part_ibc_enabled_flag** is incorporated if **non_square_ibc_enabled_flag** has a value of 1 as indicated by Note (20-3). **multi_part_ibc_enabled_flag** equal to 1 specifies that more than two prediction partitions (i.e. 2N×M and M×2N, or 2N×(N/2) and (N/2)×2N) may be used in one IntraBC predicted coding tree block. **multi_part_ibc_enabled_flag** equal to 0 specifies that no more than two prediction

10 partitions cannot be used in one IntraBC predicted coding tree block.

[0045] The modifications of Table 20B from conventional syntax table are highlighted by Notes (20-5) and (20-6). As indicated by Note (20-6), **multi_part_ibc_enabled_flag** is incorporated if **intra_block_copy_enabled_flag** has a value of 1 as indicated by Note (20-5).

15 [0046] In yet another example, a new SPS flag **log2_num_part_ibc_minus2** is used to specify the number of partitions that the current IntraBC predicted coding unit is split into. An example of the syntax and semantics is shown in Table 21.

Table 21.

	Descriptor	Note
seq_parameter_set_rbsp() {		
.....	u(4)	
sps_extension1_flag	u(1)	
if(sps_extension1_flag) {		
transform_skip_rotation_enabled_flag	u(1)	
transform_skip_context_enabled_flag	u(1)	
intra_block_copy_enabled_flag	u(1)	
if(intra_block_copy_enabled_flag) {		(21-1)
non_square_ibc_enabled_flag	u(1)	(21-2)
if(non_square_ibc_enabled_flag)		(21-3)
multi_part_ibc_enabled_flag	u(1)	(21-4)
if(multi_part_ibc_enabled_flag)		(21-5)
log2_num_part_ibc_minus2	ue(v)	(21-6)
}		
residual_dpcm_intra_enabled_flag	u(1)	
residual_dpcm_inter_enabled_flag	u(1)	
extended_precision_processing_flag	u(1)	
intra_smoothing_disabled_flag	u(1)	
sps_extension2_flag	u(1)	
}		
.....		
}		

[0047] The modifications of Table 21 from conventional syntax table are highlighted by Notes (21-1) and (21-6). As indicated by Note (21-2), **non_square_ibc_enabled_flag** is incorporated if **intra_block_copy_enabled_flag** has a value of 1 as indicated by Note (21-1). Furthermore, additional flags may also be incorporated in this case depending on test results. As indicated by Note (21-4), **multi_part_ibc_enabled_flag** is incorporated if **non_square_ibc_enabled_flag** has a value of 1 as indicated by Note (21-3). As indicated by Note (21-6), **log2_num_part_ibc_minus2** is incorporated if **multi_part_ibc_enabled_flag** has a value of 1 as indicated by Note (21-5). **log2_num_part_ibc_minus2** plus 2 specifies the value of the number of partitions in the IntraBC coding unit as follows:

$$\text{NumPartitionIntraBC} = 2^{(\text{log2_num_part_ibc}+2)}$$

For example, the IntraBC predicted CU may be evenly split into NumPartitionIntraBC partitions either in vertical or in horizontal direction.

[0048] The above description is presented to enable a person of ordinary skill in the art to practice the present invention as provided in the context of a particular application and its requirement. Various modifications to the described embodiments

will be apparent to those with skill in the art, and the general principles defined herein may be applied to other embodiments. Therefore, the present invention is not intended to be limited to the particular embodiments shown and described, but is to be accorded the widest scope consistent with the principles and novel features herein disclosed. In the above detailed description, various specific details are illustrated in order to provide a thorough understanding of the present invention. Nevertheless, it will be understood by those skilled in the art that the present invention may be practiced.

[0049] Embodiment of the present invention as described above may be implemented in various hardware, software codes, or a combination of both. For example, an embodiment of the present invention can be a circuit integrated into a video compression chip or program code integrated into video compression software to perform the processing described herein. An embodiment of the present invention may also be program code to be executed on a Digital Signal Processor (DSP) to perform the processing described herein. The invention may also involve a number of functions to be performed by a computer processor, a digital signal processor, a microprocessor, or field programmable gate array (FPGA). These processors can be configured to perform particular tasks according to the invention, by executing machine-readable software code or firmware code that defines the particular methods embodied by the invention. The software code or firmware code may be developed in different programming languages and different formats or styles. The software code may also be compiled for different target platforms. However, different code formats, styles and languages of software codes and other means of configuring code to perform the tasks in accordance with the invention will not depart from the spirit and scope of the invention.

[0050] The invention may be embodied in other specific forms without departing from its spirit or essential characteristics. The described examples are to be considered in all respects only as illustrative and not restrictive. The scope of the invention is therefore, indicated by the appended claims rather than by the foregoing description. All changes which come within the meaning and range of equivalency of the claims are to be embraced within their scope.

CLAIMS

1. A method of signaling of coding mode including an IntraBC mode (Intra-block copy mode) for a picture, wherein the picture is divided into multiple coding units (CU), the method comprising:

5 receiving input data associated with a current coding unit in a current picture, wherein the current coding unit is coded using a prediction mode selected from a prediction mode group comprising a Skip mode, an Inter mode, the IntraBC mode and an Intra mode;

if the Skip mode is selected for the current coding unit:

10 encoding or decoding the Skip mode using a first binary codeword with 1 bit; and

encoding or decoding the current coding unit without any residue information and motion information;

if the Inter mode is selected for the current coding unit:

15 encoding or decoding the Inter mode using a second binary codeword with 2 bits; and

encoding or decoding the current coding unit using temporal prediction;

if the IntraBC mode is selected for the current coding unit:

20 encoding or decoding the IntraBC mode using a third binary codeword with 3 bits; and

encoding or decoding the current coding unit using Intra motion compensated prediction based on reconstructed pixels of the current picture; and

if the Intra mode is selected for the current coding unit:

25 encoding or decoding the Intra mode using a fourth binary codeword with 3 bits; and

encoding or decoding the current coding unit using spatial prediction.

2. The method of Claim 1, wherein the first codeword, the second codeword, the third codeword and the fourth codeword correspond to {1, 00, 011, 010} respectively.

3. A method of signaling of coding mode including an IntraBC mode (Intra-block copy mode) for a picture, wherein the picture is divided into multiple coding units, the method comprising:

30 receiving input data associated with a current coding unit in a current slice of a current picture;

if the IntraBC mode is selected for the current coding unit:

encoding or decoding a partition mode associated with the IntraBC mode selected from a partition mode group for the current coding unit using a binary sub-tree representing all members of the partition mode group and the binary sub-tree consists of only said all members of the partition mode group; and

encoding or decoding the current coding unit according to the partition mode selected using Intra motion compensated prediction based on reconstructed pixels of the current picture, wherein the current coding unit is partitioned into multiple sub-blocks according to the partition mode.

4. The method of Claim 3, wherein the partition mode group consists of a $2N \times 2N$ mode indicating no partitioning, a $2N \times M$ mode for partitioning each $2N \times 2N$ block horizontally into $(2N/M)$ sub-blocks of size $2N \times M$, and an $M \times 2N$ mode for partitioning each $2N \times 2N$ block vertically into $(2N/M)$ sub-blocks of size $M \times 2N$, and wherein N and M are positive integers and M is not larger than N .

5. The method of Claim 4, wherein M is a power-of-2 integer.

6. The method of Claim 4, wherein the binary sub-tree for the $2N \times 2N$ mode, the $2N \times M$ mode and the $M \times 2N$ mode corresponds to $\{1, 01, 00\}$ respectively.

7. The method of Claim 3, wherein the partition mode group consists of a $2N \times 2N$ mode, a $2N \times N$ mode, an $N \times 2N$ mode, and an $N \times N$ mode.

8. The method of Claim 7, wherein the binary sub-tree for the $2N \times 2N$ mode, the $2N \times N$ mode, the $N \times 2N$ mode and the $N \times N$ mode corresponds to $\{1, 01, 001, 000\}$ respectively or $\{1, 001, 01, 000\}$ respectively.

9. The method of Claim 3, wherein the partition mode group consists of a $2N \times 2N$ mode, a $2N \times N$ mode and an $N \times 2N$ mode when the current coding unit is larger than 8×8 .

10. The method of Claim 9, wherein the binary sub-tree for the $2N \times 2N$ mode, the $2N \times N$ mode and the $N \times 2N$ mode corresponds to $\{1, 01, 00\}$ respectively or $\{1, 00, 01\}$ respectively.

11. The method of Claim 3, wherein the partition mode group consists of a $2N \times 2N$ mode, a $2N \times N$ mode, a $N \times 2N$ mode, an $nL \times 2N$ mode, an $nR \times 2N$ mode, a $2N \times nU$ mode and a $2N \times nD$ mode if the current coding unit is larger than 8×8 .

12. The method of Claim 11, wherein the binary sub-tree for the $2N \times 2N$ mode, the $2N \times N$ mode, the $N \times 2N$ mode, the $nL \times 2N$ mode, the $nR \times 2N$ mode, the

2NxnU mode and the 2NxnD mode corresponds to {1, 011, 001, 0100, 0101, 0000, 0001} respectively or {1, 001, 011, 0000, 0001, 0100, 0101} respectively.

13. The method of Claim 3, wherein an enable flag is incorporated in a sequence level, a picture level, or a slice level of a bitstream to indicate whether the partition mode group is allowed to include one or more non-square partition modes for a corresponding sequence, a corresponding picture, or a corresponding slice.

14. The method of Claim 3, wherein an enable flag is incorporated in a sequence level, a picture level, or a slice level of a bitstream to indicate whether the partition mode group is allowed to include one or more asymmetric partition modes for a corresponding sequence, a corresponding picture, or a corresponding slice.

15. The method of Claim 3, wherein an enable flag is incorporated in a sequence level, a picture level, or a slice level of a bitstream to indicate whether the partition mode group is allowed to include one or more multiple partition modes to partition the coding unit into more than two sub-blocks for a corresponding sequence, a corresponding picture, or a corresponding slice.

16. The method of Claim 3, wherein an enable flag is incorporated in a sequence level, a picture level, or a slice level of a bitstream to indicate a total number of sub-blocks that the coding unit is partitioned according to the total number of sub-blocks for a corresponding sequence, a corresponding picture, or a corresponding slice.

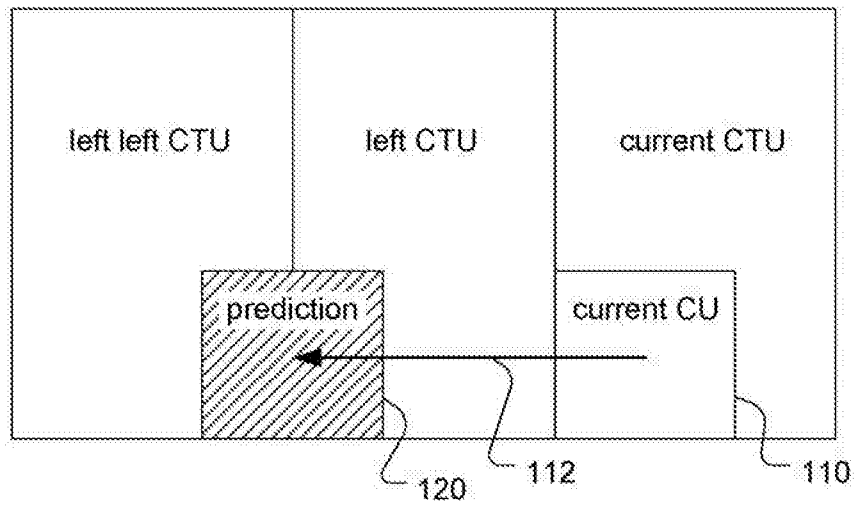

Fig.1

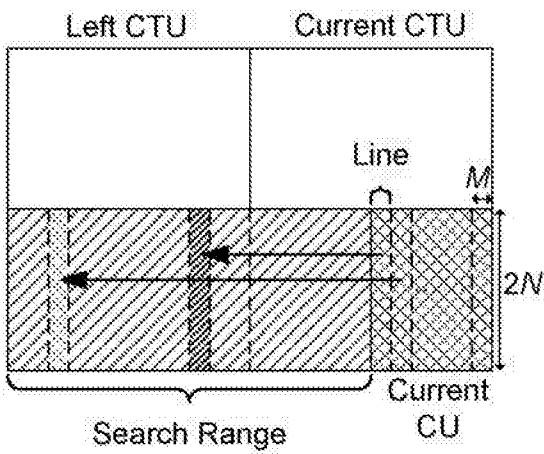

Fig.2A

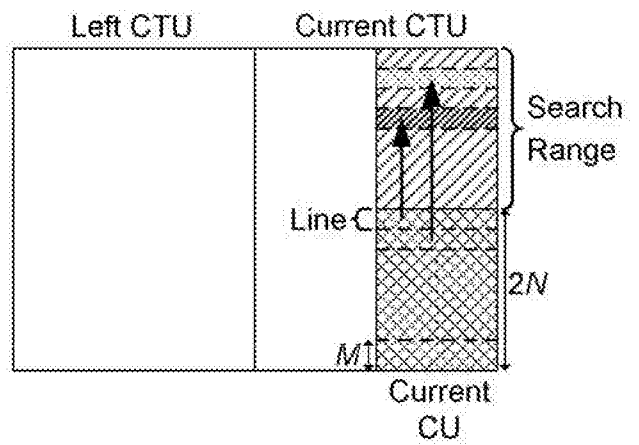

Fig.2B

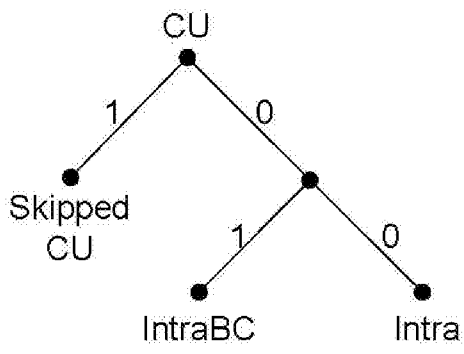

Fig.3A

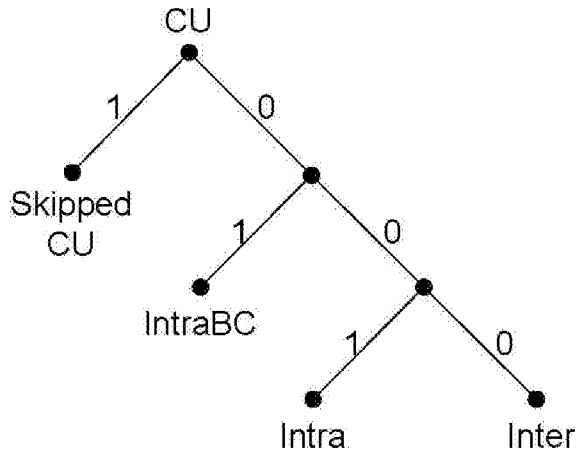

Fig.3B

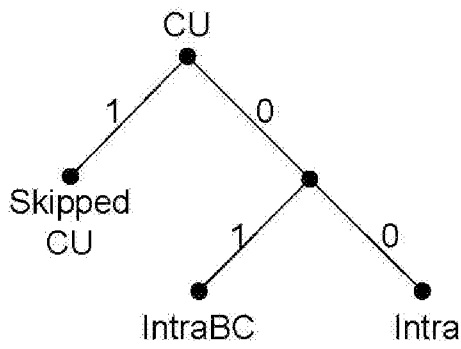

Fig.4A

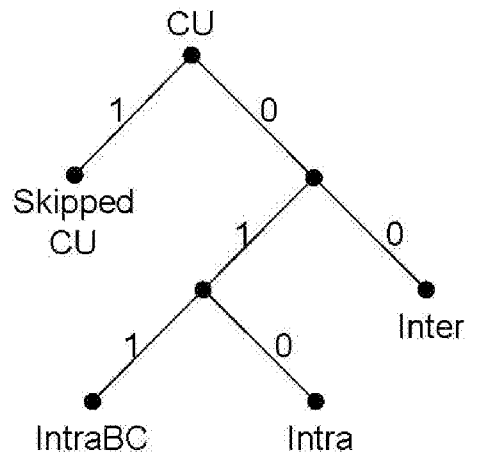

Fig.4B

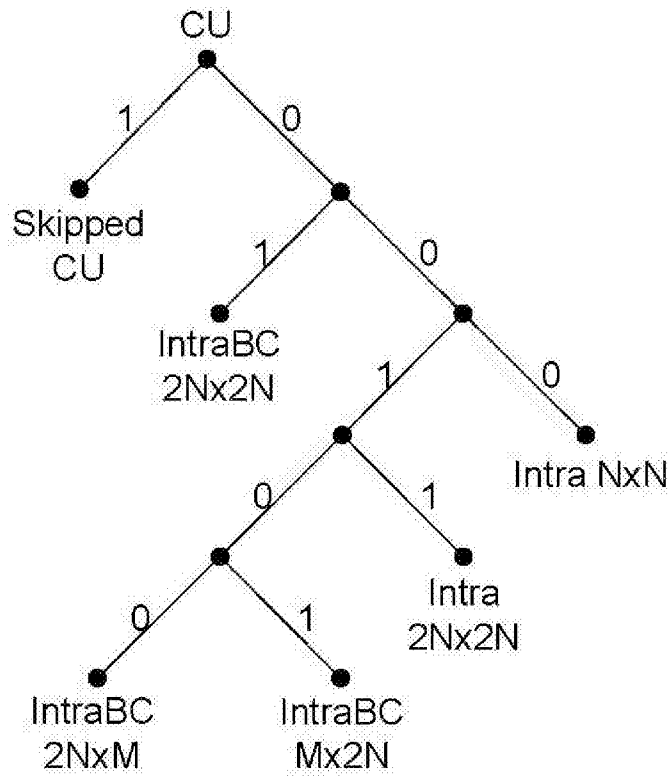

Fig.5A

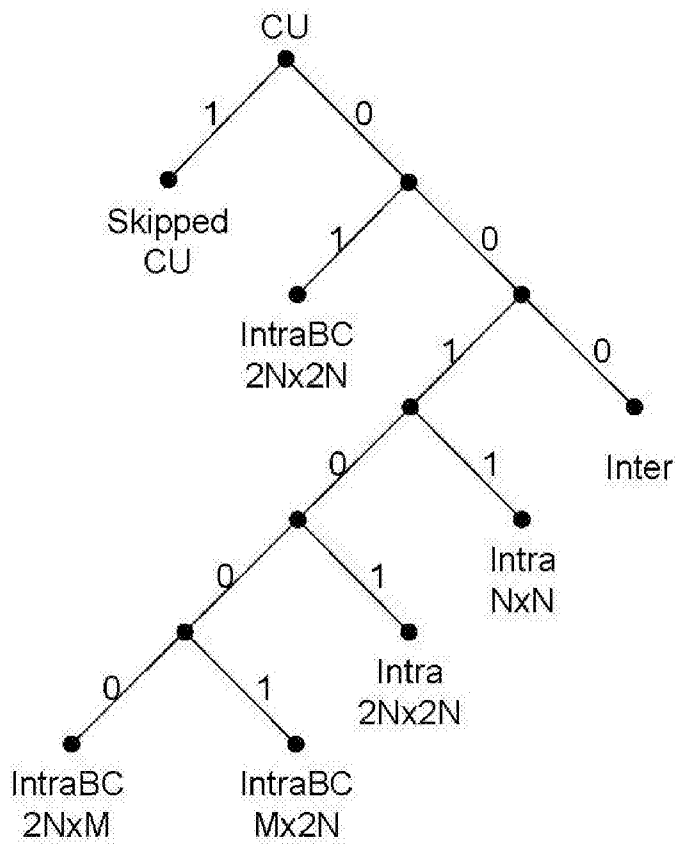

Fig.5B

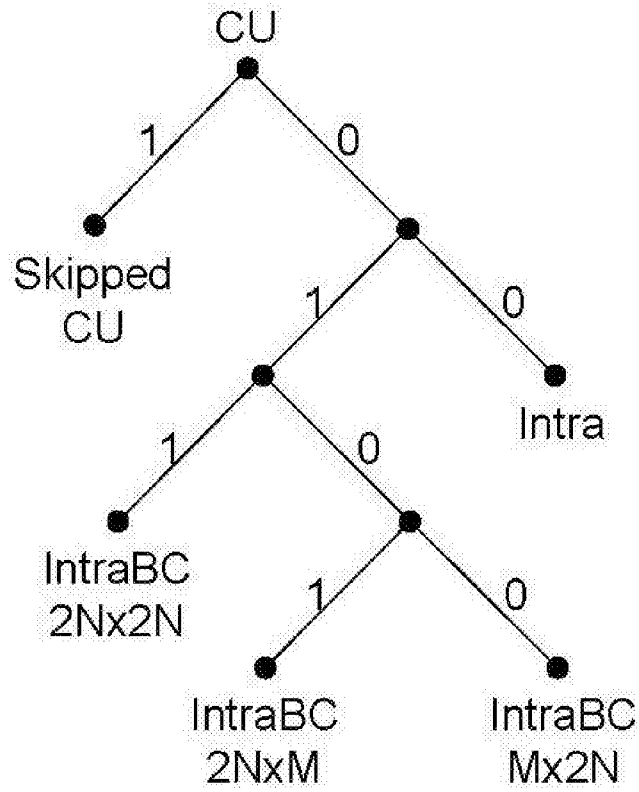

Fig.6A

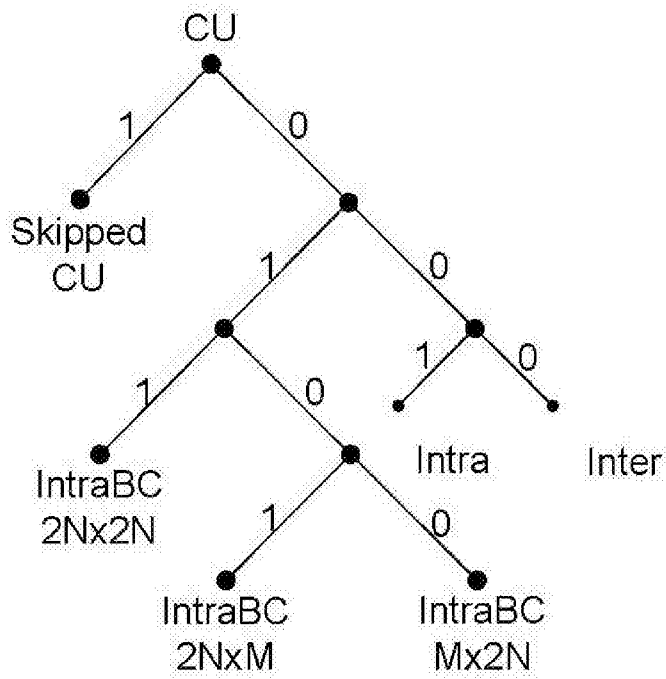

Fig.6B

INTERNATIONAL SEARCH REPORT

International application No.

PCT/CN2014/091140

A. CLASSIFICATION OF SUBJECT MATTER		
H04N 19/50(2014.01)i		
According to International Patent Classification (IPC) or to both national classification and IPC		
B. FIELDS SEARCHED		
Minimum documentation searched (classification system followed by classification symbols)		
H04N		
Documentation searched other than minimum documentation to the extent that such documents are included in the fields searched		
Electronic data base consulted during the international search (name of data base and, where practicable, search terms used)		
DWPI;SIPOABS;USTXT: HEVC, prediction, mode, intra BC, motion, skip mode, block copy, intra block copy, 3 bits, 2 bits, codeword, coding unit, 1 bit, intraBC, binary, spatial prediction, slice?, partition mode, tree, member?, group		
C. DOCUMENTS CONSIDERED TO BE RELEVANT		
Category*	Citation of document, with indication, where appropriate, of the relevant passages	Relevant to claim No.
A	US 2013083844 A1 (CHONG IN SUK ET AL.) 04 April 2013 (2013-04-04) the whole document	1-16
A	US 2009232217 A1 (SAMSUNG ELECTRONICS CO LTD) 17 September 2009 (2009-09-17) the whole document	1-16
A	US 2011249721 A1 (QUALCOMM INC) 13 October 2011 (2011-10-13) the whole document	1-16
A	US 2013188727 A1 (GEN INSTRUMENT CORP ET AL.) 25 July 2013 (2013-07-25) the whole document	1-16
A	WO 2010082886 A1 (TELEFON ERICSSON PUBL AB L M ET AL.) 22 July 2010 (2010-07-22) the whole document	1-16
<input type="checkbox"/> Further documents are listed in the continuation of Box C. <input checked="" type="checkbox"/> See patent family annex.		
* Special categories of cited documents:		
“A”	document defining the general state of the art which is not considered to be of particular relevance	“T” later document published after the international filing date or priority date and not in conflict with the application but cited to understand the principle or theory underlying the invention
“E”	earlier application or patent but published on or after the international filing date	“X” document of particular relevance; the claimed invention cannot be considered novel or cannot be considered to involve an inventive step when the document is taken alone
“L”	document which may throw doubts on priority claim(s) or which is cited to establish the publication date of another citation or other special reason (as specified)	“Y” document of particular relevance; the claimed invention cannot be considered to involve an inventive step when the document is combined with one or more other such documents, such combination being obvious to a person skilled in the art
“O”	document referring to an oral disclosure, use, exhibition or other means	“&” document member of the same patent family
“P”	document published prior to the international filing date but later than the priority date claimed	
Date of the actual completion of the international search		Date of mailing of the international search report
20 January 2015		26 January 2015
Name and mailing address of the ISA/CN		Authorized officer
STATE INTELLECTUAL PROPERTY OFFICE OF THE P.R.CHINA(ISA/CN) 6,Xitucheng Rd., Jimen Bridge, Haidian District, Beijing 100088 China		SUN, Jiachen
Facsimile No. (86-10)62019451		Telephone No. (86-10)62411520

INTERNATIONAL SEARCH REPORT
Information on patent family members

International application No.

PCT/CN2014/091140

Patent document cited in search report			Publication date (day/month/year)	Patent family member(s)			Publication date (day/month/year)
US	2013083844	A1	04 April 2013	WO	2013049309	A1	04 April 2013
US	2009232217	A1	17 September 2009	KR	20090099234	A	22 September 2009
				US	8625670	B2	07 January 2014
				KR	101431545	B1	20 August 2014
US	2011249721	A1	13 October 2011	JP	2013524734	A	17 June 2013
				CN	103098463	A	08 May 2013
				KR	20130010124	A	25 January 2013
				EP	2572509	A2	27 March 2013
				WO	2011130334	A3	06 December 2012
				WO	2011130334	A2	20 October 2011
US	2013188727	A1	25 July 2013	WO	2013109993	A1	25 July 2013
WO	2010082886	A1	22 July 2010	US	8577164	B2	05 November 2013
				JP	2012515498	A	05 July 2012
				JP	5203513	B2	05 June 2013
				US	2011235928	A1	29 September 2011
				EP	2380353	A1	26 October 2011