

B. CORTRITE.

2 Sheets—Sheet 1.

Fanning Mill.

No. 101,713.

Patented Aug. 12, 1870.

Fig. 1

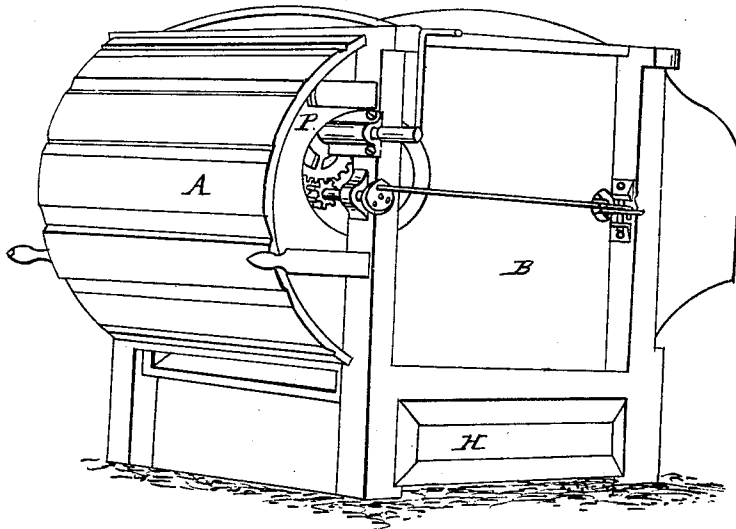
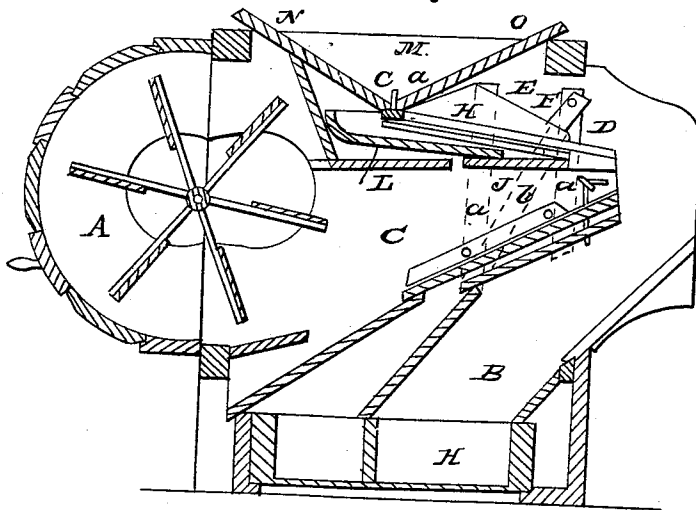

Fig. 2



WITNESSES  
G. H. Burdette  
D. C. W. Murphy

INVENTOR  
B. Cortrite  
Per Burdette & Co

B. CORTRITE.  
Fanning Mill.

2 Sheets—Sheet 2.

No. 101,713.

Patented Aug. 12, 1870.

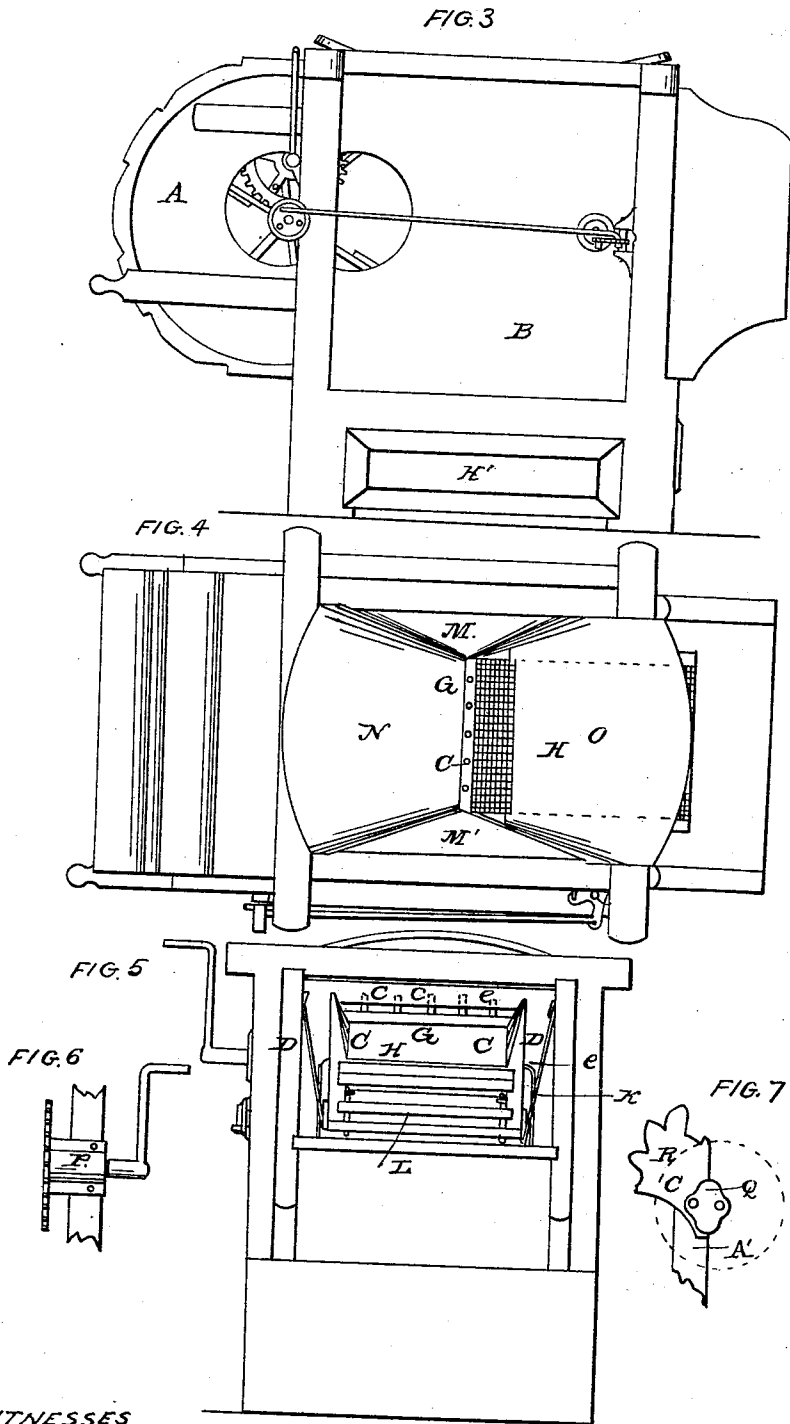

WITNESSES  
J. H. Burridge  
L. L. Humphrey

INVENTOR  
B. Cortrite  
Per Burridge & Co

# United States Patent Office.

BARNARD CORTRITE, OF NORWALK, OHIO.

Letters Patent No. 101,713, dated April 12, 1870.

## IMPROVEMENT IN FANNING-MILLS

The Schedule referred to in these Letters Patent and making part of the same

### To all whom it may concern:

Be it known that I, BARNARD CORTRITE, of Norwalk, in the county of Huron and State of Ohio, have invented a certain new and improved Fanning-Mill; and I do hereby declare that the following is a full, clear, and complete description of the same; reference being had to the accompanying drawings making part of this specification, in which—

### Drawings.

Figure 1, plate 1, is a perspective view of the mill.

Figure 2, a vertical section.

Figure 3, plate 2, is a side view of the mill.

Figure 4, a top view.

Figure 5, a view of the front end.

Figures 6 and 7, detached sections.

Like letters of reference refer to like parts in the several views.

### Objective.

The nature of this invention relates to so hanging the shoe of a fanning-mill that the rear and front end thereof shall have an equal and common vibratory movement.

It also relates to the manner of arranging the sieves and grain-boards of the shoe so that much of the chaff is separated from the grain before the application of the blast, as hereinafter more fully described.

A further improvement consists in the construction of the hopper so that its sides shall have an equal angle, said hopper being framed into the top of the mill, and with it forming a constructive part thereof, instead of being made separate therefrom.

It also relates to the construction and adaptation of a journal-seat for the axle or shaft of the fan, so that it forms an angle-iron, for securing the sides of the mill to the frame thereof, all of which is hereinafter more fully described.

### Descriptive.

Fig. 1 represents a perspective view of the mill, of which A is the fan-case thereof, and B the section, in which is arranged the shoe and sieves, the general shape, size, and construction of which are like this class of mills in ordinary use.

The shoe C, fig. 5, in which the several sieves are arranged, is suspended in the body of the mill in front by a pair of stirrups, D, the upper end of which is attached to the side of the mill, whereas the lower end is connected to the bottom of the shoe. A pair of stirrups, E, corresponding to these, suspends the rear end of the shoe.

The shoe is braced longitudinally by diagonal straps F, which, and also the stirrups, are indicated by the dotted lines *a b*.

It will be obvious that, in suspending the shoe in the manner above described, not only the toe or front of the shoe will be allowed a vibratory lateral movement, but also the heel or rear end will have the same action.

The ordinary way of attaching the shoe is to pivot the rear end, and hang up the front end, the consequence of which is that the front end only has a direct vibratory action, whereas the rear end swings around upon its pivot with but little movement in a lateral direction, and not sufficient to shake up the grain in order that it may run through the sieves.

This difficulty is avoided by hanging the shoe as above described, as both ends are shaken alike, and the grain thereby caused to pass through the sieves much more readily and with greater uniformity than in the old way.

To facilitate the passage of the grain to the hopper, an agitator, G, figs. 4 and 5, is attached to the rear end of the shoe.

Said agitator consists of a series of fingers, *c*, projecting upward from the shoe into the hopper, which, as said shoe vibrates, they also vibrate with it, thereby constantly agitating the grain in the throat of the hopper, and preventing it from lodging therein.

The sieves are arranged in the shoe in the order as follows:

The first or uppermost one, H, fig. 4, extends back to the rear of the shoe; therefrom directly under the throat of the hopper. Mills as ordinarily made have a grain-board immediately under the throat, instead of a sieve, upon which the grain falls; thence onto a coarse sieve or series of sieves. In this way all or most of the small foul stuff runs through the sieves with the grain, and is either separated by being blown out of the pan, or by the use of a number of screens introduced for that purpose, the result of which is that much grain is blown out with the foul stuff and lost, and more or less of the foul stuff goes through along with the grain. This objection is avoided by allowing the grain to fall directly from the hopper onto the screen, through which most of the foul stuff and small seeds will fall onto the seed-boards L and J, fig. 2, immediately under the sieve H, and to which it forms a close tight bottom. The seeds, &c., escape from under the screen H through openings on each side of the shoe at the points *e*, fig. 5, and are conveyed into the seed-box H' by conductors K, attached to the outsides of the shoe. By this means the grain falls over the front end of the sieve H, and is exposed to the wind as it falls down upon the lower range of sieves, with much less foul stuff to be blown out by the fan, therefore requiring less wind to clean the grain and labor to run the mill.

A further improvement consists in constructing the

hopper M, fig. 2, so as to form permanently a part of the machine, and not detachable therefrom. The two lateral sides of the hopper are secured in a permanent manner to the sides of the mill; so also is the rear end N, whereas the front end O is movable therein, grooves being cut in the inner sides of the wall, in which the end is fitted so as to slide upward or downward, for opening or closing the bottom or throat of the hopper, as may be required.

It will be observed that each of the two opposite sides of the hopper are arranged at an equal angle, the purpose of which is to allow the grain to plow down and out of the hopper equally from all sides; therefore it is less liable to lodge upon the sides of the hopper, and will be fed more evenly than if the sides were of unequal angles.

A further improvement consists in the journal-box, in which runs the shaft of the fan. Said box consists of a long sleeve, P, fig. 1, in which is fitted and runs the journal of the shaft.

From the inner end of the sleeve projects at right angles a lug, Q, which, together with the sleeve, forms an angle-iron.

By the use of this peculiar angle-iron and journal-box, the side of the mill is firmly secured to the front of the frame, as shown in fig. 7, in which R represents a section of the side of the mill; Q, the lug of the iron; and A', the post.

In said figure it will be seen that the lug embraces

the side of the mill, and is secured thereto by a screw or bolt, d, whereas the sleeve part of the box is bolted to the part as seen in fig. 6.

It will be obvious that, by this means, the shaft of the fan is not only provided with a journal-box, but that the side of the mill and port are connected in a most substantial manner, thereby making the machine stronger and more durable.

#### *Claims.*

What I claim as my improvement, and pray may be granted to me by Letters Patent, is—

1. The angle-iron and journal-box P, when combined and applied to the purposes in the manner substantially as specified.

2. The auxiliary screen H and conductors K, in combination with the shoe C, agitator G, and hopper, substantially as and for the purpose described.

3. The arrangement of the agitator G and shoe C, in combination with the hopper M, when said hopper is so constructed as to form a part of the frame-work of said mill, and provided with the slide O, and groove for the same in the sides of the frame, as and for the purpose substantially as set forth.

B. CORTRITE.

Witnesses:

ETHAN A. PRAY,  
JOHN KENNAN.