



12

## EUROPEAN PATENT SPECIFICATION

45 Date of publication of patent specification :  
**03.03.93 Bulletin 93/09**

51 Int. Cl.<sup>5</sup> : **E03D 9/03**

21 Application number : **90201892.8**

22 Date of filing : **12.07.90**

54 **Delayed release dispenser.**

30 Priority : **27.07.89 GB 8917224**

43 Date of publication of application :  
**20.02.91 Bulletin 91/08**

45 Publication of the grant of the patent :  
**03.03.93 Bulletin 93/09**

84 Designated Contracting States :  
**CH DE ES FR GB IT LI NL SE**

56 References cited :  
**EP-A- 0 102 891**  
**EP-A- 0 168 075**  
**EP-A- 0 268 945**  
**AT-B- 374 859**

73 Proprietor : **UNILEVER N.V.**  
**Weena 455**  
**NL-3013 AL Rotterdam (NL)**

84 **CH DE ES FR IT LI NL SE**  
Proprietor : **UNILEVER PLC**  
**Unilever House Blackfriars P.O. Box 68**  
**London EC4P 4BQ (GB)**

84 **GB**

72 Inventor : **Rennie, George Kerr**  
**Port Sunlight Lab., Quarry Road East**  
**Bebington, Wirral, Merseyside L63 3JW (GB)**

74 Representative : **Elliott, Peter William et al**  
**Unilever PLC Patent Division Colworth House**  
**Sharnbrook**  
**Bedford MK44 1LQ (GB)**

**EP 0 413 373 B1**

Note : Within nine months from the publication of the mention of the grant of the European patent, any person may give notice to the European Patent Office of opposition to the European patent granted. Notice of opposition shall be filed in a written reasoned statement. It shall not be deemed to have been filed until the opposition fee has been paid (Art. 99(1) European patent convention).

## Description

The present invention relates to a dispenser. More in particular, it relates to a delayed release dispensing system for delivering amounts of a chemical product to a discontinuous stream of a fluid, such as the flush water in a toilet. The chemicals to be delivered by the dispenser may be cleansing agents, sanitizing agents, deodorants and the like.

Cistern dosing devices are known. EP-168 075 discloses a passive dosing dispenser for immersion in a still body of water as found in a toilet cistern. The body of water is intermittently replaced. This complex device is particularly adapted to dispense chemicals into a body of water when immersed in the water for an extended period of time.

Lavatory rim block dispensing devices are also known, in the art. They may, for instance, comprise a cage-like container with holds and a hook for mounting inside the toilet bowl. Inside the container there is a solid block of sparingly soluble cleansing agent, which is continuously delivered to the flush water for the duration of the flush.

When such cage-like containers are used, most of the delivered cleaning agent does not remain in the bowl to fulfil its cleansing purposes but is directly flushed into the sewage system. This inefficiency constitutes an economical disadvantage and is environmentally undesirable there being a growing tendency from an environmental point of view to reduce the amount of chemicals which are fed into the sewage system. Moreover, it is often difficult to attain an effective level of the chemical in the toilet bowl because of the block of chemical is sparingly soluble and delivery only takes place during the relatively short period of the flush.

It has therefore been proposed to provide a time delay to the in-bowl; dispensing systems, such that the greater part of the chemical is only added to the last part of the flush water, most of which remains in the bowl after the flush.

For instance, the European patent application EP-92,283 (Unilever) describes a cage-like toilet bowl dispenser which is equipped with a siphon system in order to achieve a time delay during the flush cycle. Although such a dispenser functions satisfactorily in that some of the dissolved chemical is delivered at the end of the flush, the efficiency is still low. Furthermore, drip stains are sometimes observed and the cost of manufacturing is high due to the complexity of the siphon system.

The international patent application WO-83/01974 (Wellcome) discloses a liquid dispensing system for connecting to a flush-water pipe, comprising a connecting pipe and a casing having therein a chamber a float-operated valve, whereby a predetermined amount of a liquid product is dispensed into the chamber when the chamber is flooded with flush wa-

ter.

It is an object of the present invention to provide an improved delayed release dispensing system which obviates the above-mentioned disadvantages. Above all, it should effectively provide a time delay such that the chemicals are used more efficiently and at the same time the system should be easy and economical to manufacture.

We have now found that these and other objects can be achieved by the delayed release dispensing system of the present invention which comprises a substantially closed container for holding the chemical product and fastening means for mounting the container, said container having an opening both for receiving the steam of a fluid, such as water, and for allowing it to flow out again after a delay, said system being free of any moving parts.

There are provided means to direct the steam of the fluid to the opening in the container.

It is advantageous in the dispensing system according to the invention if the opening is placed above the lowest point of the container, such that some of the fluid is retained inside the container after the stream of the fluid has ceased.

Preferably, there are provided one or more further openings in the upper part of the container for equalizing the air pressure in and outside the container when the container is being filled with the fluid.

It is especially preferred when the opening in the container for letting the fluid in and out is non-wetting to the fluid to reduce dripping. For use with aqueous liquids, the openings may have a hydrophobic finish to reduce dripping. Alternatively, the entire container may be made from an hydrophobic material or an hydrophobic insert may be introduced in the openings. Suitable materials for these purposes include for instance poly tetra-fluoro ethylene (teflon) and silicone resins.

The dispensing system according to the invention may be used as a toilet bowl dispensing system. In that case, the fluid is water and there are provided fastening means to mount the container inside a toilet bowl. It is preferred when there are also provided means to lock the dispensing system in place under the rim of the toilet bowl. For example, a pin may be provided which fits into a hole under the rim.

Preferably, there is provided a secondary support inside the container to cradle the block of chemical. The dispenser of the invention may further comprise one or more additional compartments which are open to the atmosphere, and which are designed to deliver volatile components such as perfume, from a suitable impregnated pad, a chemical block or gel.

The dispensing system according to the invention may also be used inside spray-cleaning machines such as dish washing machines, more in particular in industrial ware washing machines. In that case, the dispenser comprises a deflector funnel to

direct the water to the opening in the container.

According to a further embodiment of the invention, the dispensing system may be attached to the end of pipes and taps. In that case it comprises a suitable clamping device and a deflector to direct the fluid into the container.

The invention will now be further illustrated by means of the following specific descriptions, in which:

Figure 1 is a schematic cross-section through a toilet bowl dispensing system according to the invention.

Figure 2 is a schematic projection of the toilet bowl dispensing system shown in figure 1 along the line A-A.

Figure 3 is a schematic perspective view of a dispensing system according to the invention for use in a mechanical ware washing machine.

Figure 4 is a schematic perspective view of a dispensing system according to the invention attached to a pipe or tap.

Figure 5 is a schematic perspective view of a dispensing system according to the invention for use in the sink on top of a Japanese type of toilet.

Figure 1 is a cross-section through a toilet bowl dispensing system showing a substantially closed container 1 to be held close to the flush water channel by an appropriate hanger 2 which fits onto the toilet rim. Inside the container 1 there is a block of a sparingly soluble chemical 3, suitable for cleaning and sanitizing a toilet bowl. Such blocks are known in the art. Furthermore, the container 1 possesses a hole 4 allowing the flush water which may be taken from the flush stream by a deflector 5 to enter the container 1. Near the end of the flush the pressure of the water flow into the container 1 decreases and is finally reduced to zero. The water inside the container which has been in contact with the block of chemical for some time now flows back through the opening 4 into the toilet bowl. Through the optional holes 6 at the top of the device air may escape during the filling phase, thereby allowing more water to enter the container. The air may be perfumed so that a perfume is dispensed during the early stages of flushing the toilet. In a depicted preferred embodiment a sump 7 is formed because the opening 4 is situated above the lowest point of the container 1. A small volume of water is retained in this sump, dissolving some of the chemical to form a solution ready for the next flush.

Although in the depicted situation there is only one container 1, it can also be envisaged that there are provided more containers, each containing a separate type of chemical. This is especially useful when several mutually incompatible chemicals have to be dispensed.

In figure 2 a schematical projection of the device of figure 1 is shown along the line A-A. It shows a wedge-shaped part 5 to direct the flow of flush water to the opening 4 in the container 1.

Figure 3 shows a dispensing system according to the invention for use in a mechanical ware washing machine. The discontinuous stream of water originates from the rotating spray arms or a shower head. The device comprises a substantially closed container 10 holding a sparingly soluble block of chemical 13, which is in this case a caustic detergent composition. By means of the fastening means 12 for mounting the container, the device is positioned inside the machine to receive water from the shower head. The container has an opening 14 allowing the spray water caught in the deflector funnel 15 to enter the container rapidly to contact the block of chemical. The entry of the spray water is facilitated by the small opening 16 for equalizing the pressure inside and outside the container. When the funnel water back pressure is reduced near the end of the spraying, a solution of the chemical flows back from the opening 14 via opening 18 into the interior of the machine. In the shown preferred embodiment of the invention, the opening 14 is positioned above the lowest point of the container 10 such that a residual amount of water is left in sump 17 to dissolve some of the chemical for the next spraying cycle.

Figure 4 shows a dispensing system according to the invention for use on an inlet pipe or tap. The discontinuous stream of fluid indicated by the arrows originates from a pipe or tap 21. The device comprises a substantially closed cylindrical container 20 holding one or more blocks of a chemical 23. The device is held at the end of a pipe 21 by means of fastening means 22, such that liquid may flow through the device. The container 20 has an opening 24 allowing liquid to enter until it is filled or until the back pressure stops the entry of further liquid. The liquid is directed towards the opening 24 by the deflection means 25. When the liquid pressure is reduced, for example when the tap is closed, the liquid containing the chemical flows from the container through opening 24 and down the pipe. In the shown embodiment the opening 24 is positioned above the lowest point of the container such that a residual amount of liquid is left to dissolve some of the chemical 23 for the next time liquid is drawn from the pipe.

Figure 5 shows a dispensing system according to the invention for use in the sink which can be found on top of a Japanese-type toilet. The water used to wash the hands is thereby collected in a tank and used subsequently to flush the toilet. The device according to the invention is placed onto the drain of the sink and is thus used to deliver an amount of cleaning or sanitizing agent to the flush water in the toilet. The device shown in Figure 5 comprises a substantially closed container 26 having therein a block of a sparingly soluble chemical 27, suitable for cleaning and sanitizing a toilet bowl. As said before, such blocks are known in the art. The device also possesses fastening means in the form of two hooks 28 to keep it

in place onto the drain of the sink. The upwardly curved edge 29 of the device causes the water falling from the tap to enter the container via hole 30. When the tap is closed and there is no longer water dropping onto the device, the pressure of the water flow into the container decreases and is finally reduced to zero. The water inside the container which has been in contact with the block of chemical for some time now flows back through the opening 30 onto the edge 29. This edge comprises a number of small holes 31 which allow the water to flow down the drain of the sink into the tank, where it is kept until the toilet is flushed again.

### Claims

1. Dispensing system for delivering amounts of a chemical product to a discontinuous stream of a fluid, comprising a substantially closed container (1) for holding the chemical product (3) and fastening means (2) for holding the container in place, said container having an opening (4) both for receiving the stream of a fluid and for allowing it to flow out again after a delay, characterised in that it has means (5) to direct the stream of fluid to the opening in the container, said system being free of any moving parts.
2. Dispensing system according to Claims 1, wherein the opening (4) is placed above the lowest point of the container, such that some of the fluid is retained inside the container after the stream of fluid has ceased.
3. Dispensing system according to Claims 1-2, whereby there are provided one or more further openings (6) in the upper part of the container for equalizing the air pressure in and outside the container when the container is being filled with fluid.
4. Dispensing system according to claims 1-3, whereby the opening (4) in the container is non-wetting to the fluid to reduce dripping.
5. Dispensing system according to Claim 4, whereby the opening (4) in the container has a hydrophobic finish to reduce dripping of an aqueous fluid.
6. Dispensing system according to Claims 1-5 for use inside a toilet bowl, comprising fastening means for mounting the container inside a toilet bowl.
7. Dispensing system according to Claim 6, further comprising means to lock the system in place un-

der the rim of the toilet bowl.

8. Dispensing system according to Claim 1-5 for use in spray-cleaning machines, comprising a deflector funnel (15) to direct the water to the opening (14) in the container (10).
9. Dispensing system according to Claim 1-5 for use on the end of pipes and taps, comprising a suitable clamping device (22) and a deflector (25) to direct the fluid to the opening (24) in the container (20).

### 15 Patentansprüche

1. Spendersystem zur Abgabe einer Menge eines chemischen Produktes an einen diskontinuierlichen Strom eines Fluids, mit einem im wesentlichen geschlossenen Container (1), zum Halten des chemischen Produktes (3), und mit Befestigungsmitteln (2), die den Container an Ort und Stelle halten, wobei der Container eine Öffnung (4), sowohl für das Eindringen des Stromes eines Fluids, als auch, um diesem nach einer Verzögerung wieder das Ausfließen zu gestatten, aufweist, dadurch gekennzeichnet, daß es Einrichtungen (5), zum Leiten des Stroms des Fluids zu der Öffnung im Container aufweist, wobei das System frei von jeglichen beweglichen Teilen ist.
2. Spendersystem gemäß Anspruch 1, bei welchem die Öffnung (4) oberhalb des tiefsten Punktes des Containers plaziert ist, so daß etwas von dem Fluid innerhalb des Containers zurückbleibt, nachdem der Strom des Fluids geendet hat.
3. Spendersystem gemäß Anspruch 1 bis 2, wobei sich zum Ausgleich des Luftdruckes innerhalb und außerhalb des Containers, wenn der Container mit dem Fluid gefüllt wird, eine oder mehrere weitere Öffnungen (6) im oberen Teil des Containers befinden.
4. Spendersystem gemäß Ansprüchen 1 bis 3, wobei die Öffnung (4) in dem Container nicht-benetzend für das Fluid ist, um das Tropfen zu reduzieren.
5. Spendersystem gemäß Anspruch 4, wobei die Öffnung (4) in dem Container eine hydrophobische Oberfläche besitzt, um das Tropfen eines wässrigen Fluids zu reduzieren.
6. Spendersystem gemäß den Ansprüchen 1 bis 5 zur Benutzung in einem Toilettenbecken, mit Befestigungsmitteln zum Montieren des Containers innerhalb eines Toilettenbeckens.

7. Spendersystem gemäß Anspruch 6, weiterhin mit Einrichtungen zum Festhalten des Systems an Ort und Stelle unter dem Rand des Toilettenbeckens.
8. Spendersystem gemäß den Ansprüchen 1 bis 5 zur Benutzung in Sprühreinigungsmaschinen, mit einem Ablenktrichter (15) zum Leiten des Wassers zu der Öffnung (14) im Container (10).
9. Spendersystem gemäß den Ansprüchen 1 bis 5 zur Benutzung am Ende von Rohren und Hähnen, mit einem geeigneten Klemmteil (22) und einer Ablenkrichtung (25) zur Leitung des Fluids zu der Öffnung (24) im Container (20).

5

10

15

### Revendications

1. Système distributeur destiné à fournir certaines quantités d'un produit chimique à un courant discontinu d'un fluide, comportant un récipient (1) sensiblement fermé destiné à contenir le produit chimique (3) et des moyens (2) de fixation destinés à maintenir en place le récipient, ledit récipient ayant une ouverture (4) destinée à la fois à recevoir le courant d'un fluide et à lui permettre de s'écouler en ressortant après un retardement, caractérisé en ce qu'il possède des moyens (5) pour diriger le courant de fluide vers l'ouverture ménagée dans le récipient, ledit système étant exempt de quelques pièces mobiles que ce soit.
2. Système distributeur conforme à la Revendication 1, dans lequel l'ouverture (4) est placée au-dessus du point le plus bas du récipient, de manière qu'une certaine quantité du fluide soit retenue à l'intérieur du récipient après que le courant de fluide a cessé.
3. Système distributeur conforme aux Revendications 1 - 2, grâce auquel sont ménagées une ou plusieurs autres ouvertures (6) dans la partie supérieure du récipient pour égaliser la pression d'air à l'intérieur et à l'extérieur du récipient lorsque ce récipient est en train d'être rempli de fluide.
4. Système distributeur conforme aux revendications 1 - 3, grâce auquel l'ouverture (4) ménagée dans le récipient n'est pas susceptible d'être mouillée par le fluide de façon à réduire l'égouttement.
5. Système distributeur conforme à la revendication 4, grâce auquel l'ouverture (4) ménagée dans le récipient présente un fini hydrophobe de façon à réduire l'égouttement d'un fluide aqueux.

20

25

30

35

40

45

50

55

6. Système distributeur conforme aux Revendications 1 - 5 destiné à être utilisé à l'intérieur d'une cuvette de water-closet, comportant des moyens de fixation destinés à installer le récipient à l'intérieur d'une cuvette de water-closet.
7. Système distributeur conforme à la Revendication 6, comportant en outre des moyens de verrouiller le système en place sous le rebord de la cuvette de water-closet.
8. Système distributeur conforme aux Revendications 1 - 5 destiné à être utilisé dans des machines de nettoyage par pulvérisation, comportant un entonnoir formant déflecteur (15) pour diriger l'eau vers l'ouverture (14) ménagée dans le récipient (10).
9. Système distributeur conforme aux revendications 1 - 5 destiné à être utilisé sur l'extrémité de tuyaux et de robinets, comportant un dispositif approprié (22) de serrage et un déflecteur (25) pour diriger le fluide vers l'ouverture (24) ménagée dans le récipient (20).

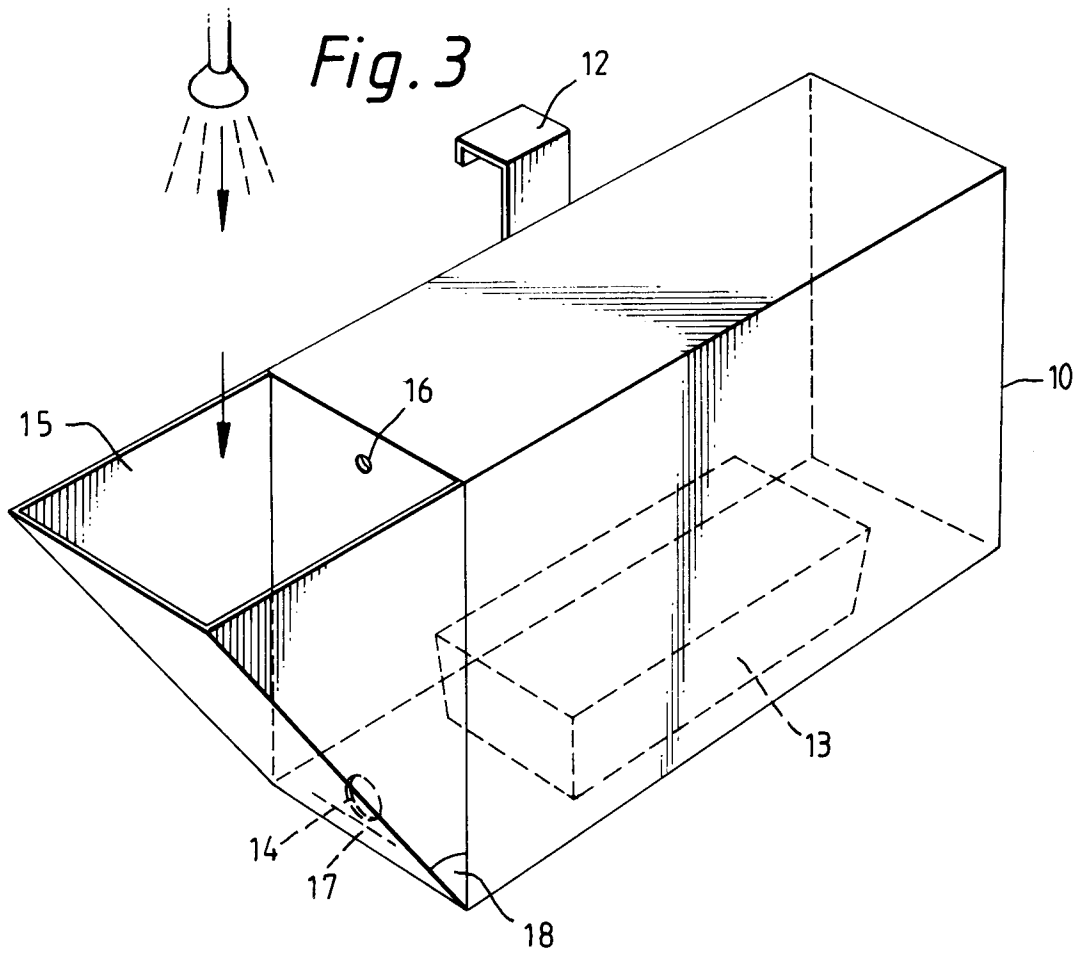
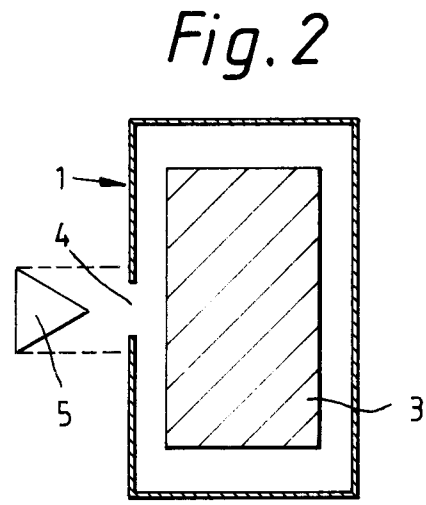
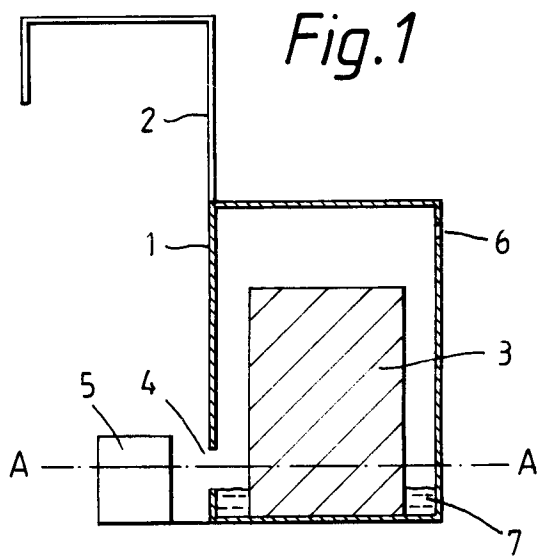

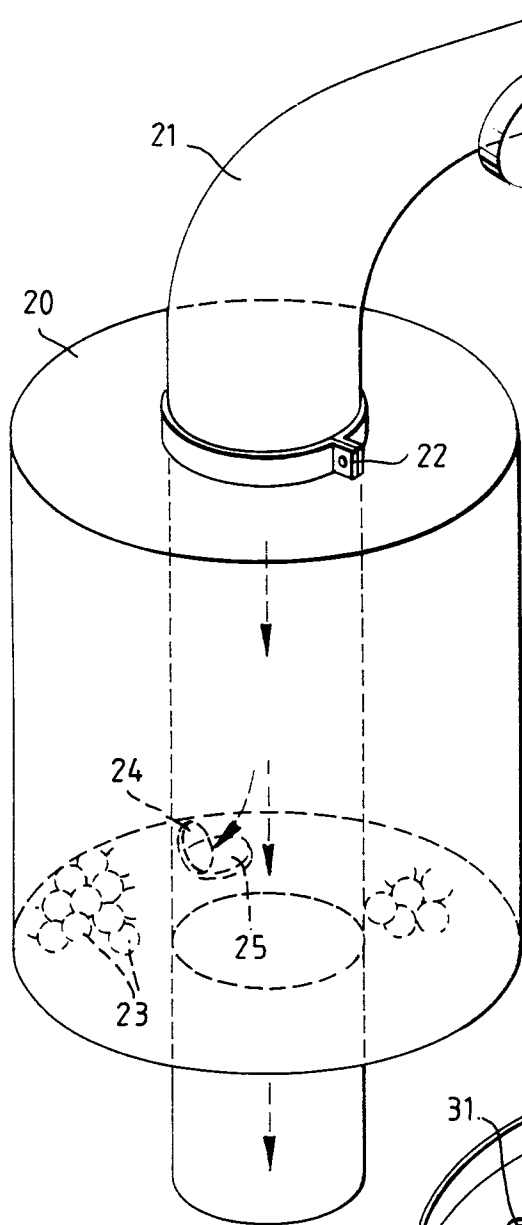

Fig. 4

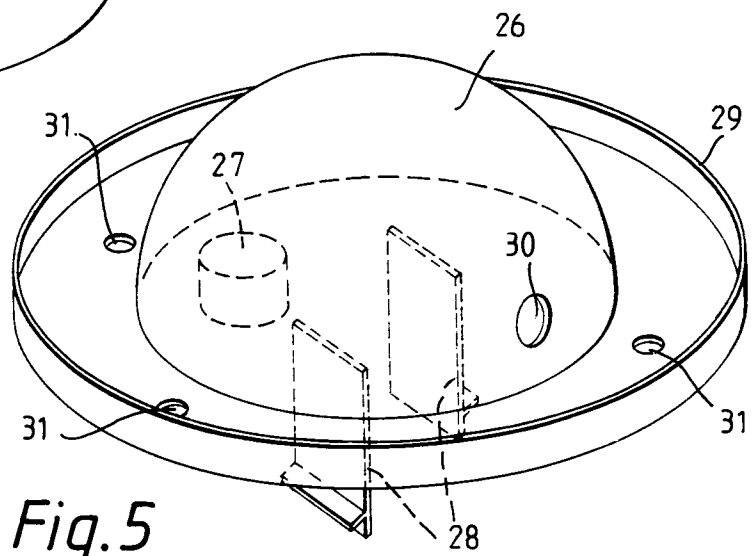

Fig. 5