



INTERNATIONAL APPLICATION PUBLISHED UNDER THE PATENT COOPERATION TREATY (PCT)

<p>(51) International Patent Classification ⁶ : G09F 3/18, 3/20, 7/18, 19/22, E01F 9/04, 9/06</p>	<p>A1</p>	<p>(11) International Publication Number: WO 95/16255 (43) International Publication Date: 15 June 1995 (15.06.95)</p>
---	------------------	---

(21) International Application Number: PCT/NZ94/00141

(22) International Filing Date: 9 December 1994 (09.12.94)

(30) Priority Data:
250430 10 December 1993 (10.12.93) NZ

(71)(72) Applicant and Inventor: SKIPPER, Meihana, Wayne
[NZ/NZ]; 5rd Waughs Road, Fielding (NZ).

(74) Agents: WEST-WALKER, Francis, Nigel et al.; West-Walker
McCabe, 3rd floor, Fraser House, 160-162 Willis Street,
Wellington 6001 (NZ).

(81) Designated States: AM, AT, AU, BB, BG, BR, BY, CA, CH, CN, CZ, DE, DK, EE, ES, FI, GB, GE, HU, JP, KE, KG, KP, KR, KZ, LK, LR, LT, LU, LV, MD, MG, MN, MW, NL, NO, NZ, PL, PT, RO, RU, SD, SE, SI, SK, TJ, TT, UA, US, UZ, VN, European patent (AT, BE, CH, DE, DK, ES, FR, GB, GR, IE, IT, LU, MC, NL, PT, SE), OAPI patent (BF, BJ, CF, CG, CI, CM, GA, GN, ML, MR, NE, SN, TD, TG), ARIPO patent (KE, MW, SD, SZ).

Published

*With international search report.
Before the expiration of the time limit for amending the claims and to be republished in the event of the receipt of amendments.*

(54) Title: INDICATOR DEVICE

(57) Abstract

An indicator device primarily for outdoor use and which can house a sign in a manner that the sign will be protected from damage and yet be readily visible. The device consists of an escutcheon (10) at least a portion of which is transparent, with the escutcheon being formed in a manner that it can clip over a rim of a base member (15) to cover at least one face of the base member (15). A display member (12) which can carry indicia can be positioned on the base member (15) so the indicia will be visible through the transparent portion of the escutcheon (10). Means are provided to attach the base member (15) to a surface.

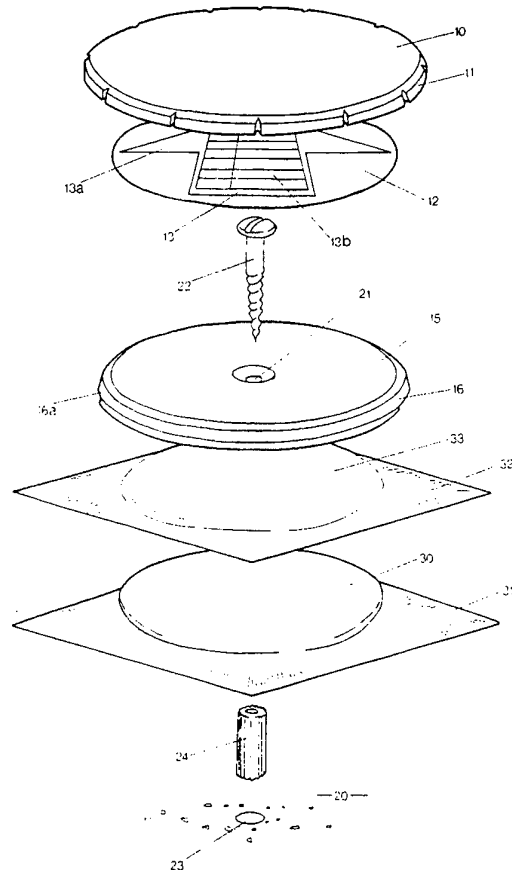

FOR THE PURPOSES OF INFORMATION ONLY

Codes used to identify States party to the PCT on the front pages of pamphlets publishing international applications under the PCT.

AT	Austria	GB	United Kingdom	MR	Mauritania
AU	Australia	GE	Georgia	MW	Malawi
BB	Barbados	GN	Guinea	NE	Niger
BE	Belgium	GR	Greece	NL	Netherlands
BF	Burkina Faso	HU	Hungary	NO	Norway
BG	Bulgaria	IE	Ireland	NZ	New Zealand
BJ	Benin	IT	Italy	PL	Poland
BR	Brazil	JP	Japan	PT	Portugal
BY	Belarus	KE	Kenya	RO	Romania
CA	Canada	KG	Kyrgystan	RU	Russian Federation
CF	Central African Republic	KP	Democratic People's Republic of Korea	SD	Sudan
CG	Congo	KR	Republic of Korea	SE	Sweden
CH	Switzerland	KZ	Kazakhstan	SI	Slovenia
CI	Côte d'Ivoire	LI	Liechtenstein	SK	Slovakia
CM	Cameroon	LV	Latvia	SN	Senegal
CN	China	LU	Luxembourg	TD	Chad
CS	Czechoslovakia	MC	Monaco	TG	Togo
CZ	Czech Republic	MD	Republic of Moldova	TJ	Tajikistan
DE	Germany	MG	Madagascar	TT	Trinidad and Tobago
DK	Denmark	ML	Mali	UA	Ukraine
ES	Spain	MN	Mongolia	US	United States of America
FI	Finland			UZ	Uzbekistan
FR	France			VN	Viet Nam
GA	Gabon				

INDICATOR DEVICE

This invention relates to an improved indicator device and in particular the invention relates to an indicator device which is particularly adapted to be directly attached to a surface and which has the facility to display a variety of indicia and which is able to substantially protect the displayed indicia from damage.

Technical Field

Various forms of indicator devices are already known such as plaques which can be formed of metal or of a plastics material and on which indicia can be either cast, inscribed or written. Such plaques are generally utilized to be fixed for instance to the walls of buildings, to walls, posts, fences and the like to display information. The fixing for such plaques is often screws or the like which have exposed heads and which therefore invite the unwanted removal of the plaque.

A further disadvantage with known indicator devices is that the face carrying the information or indicia is exposed and consequently is subject to the effects of the weather particularly if the indicator is located in an outdoor situation.

Background Art

It is known to produce indicator devices which can have a reflecting surface and which are generally of a disk shape and which can be used for instance for road marking. Such indicators generally have a reflectorized surface on one face and a suitable adhesive on the other face so that the disk can be permanently attached by the adhesive to a surface such as the road.

A major disadvantage with known indicator devices is that if they are to display indicia and the device is to be located where they are accessible or liable to damage or wear, then the indicia has to be of a permanent nature. This is usually effected by inscribing or casting the indicia on the exposed face of the indicator device during the

manufacture of the indicator device. This severely limits the versatility of the indicator device.

It is apparent the need exists for an indicator device that is not only resistant to the effects of the weather and which will provide a degree of protection to the indicia displayed on the indicator device but which is also versatile in that the indicia can be incorporated with the indicator device subsequent to manufacture of the device.

Objects of the Invention

It is therefore an object of this invention to provide an improved indicator device which will enable indicia to be readily applied to a visible surface and be protected from damage and for the device to have the facility of being easily attachable either permanently or removably to a suitable surface.

Disclosure of the Invention

Accordingly, one form of the invention may be said to comprise an indicator device consisting of:

- a base member adapted to be secured to a surface,
- an escutcheon, at least a portion of which is substantially transparent, the said escutcheon being adapted to be secured to the base member, and
- a display member to receive and display indicia and to be positioned between the said base member and the escutcheon.

Brief Description of the Drawings

Preferred forms of the invention will now be described with the aid of the accompanying drawings wherein:

- Fig. 1 is a plan view of one preferred form of the indicator device,
- Fig. 2 is a side elevation of the indicator device shown in Fig. 1,
- Fig. 3 is a sectional view along the line III-III of Fig. 1, and

Fig. 4 is an exploded view of the preferred form of the indicator device shown in Fig. 1.

Modes for Carrying out the Invention

Referring to the drawings, the indicator device is preferably formed of a number of elements which are more particularly illustrated in Fig. 4. As shown in this Figure, the indicator device includes an escutcheon 10 which is preferably formed from a clear or substantially clear plastics material such as a ultraviolet rated polycarbonate material. The escutcheon as indicated in the drawing is essentially circular and is of a dished formation and has a rim 11 which depends from the face of the escutcheon. A display member 12 is also of a circular formation and may be formed from a suitable metal sheet or a plastics material, cardboard or the like. The obverse face of the display member is essentially planar and is so formed or coated that indicia such as that indicated at 13 may be inscribed on the face. In one form, when the indicator device is intended to point to a desired location, the display member can include an outline such as the arrow 13. The space on the display member bounded by the outline of the arrow may include an area divided into a chart 13b to assist in the setting out the indicia which is to be additionally displayed within the chart.

The display member 12 may have suitable adhesive material which may be of a removable or permanent variety located on the reverse face so that the display member can be presented to and adhered to a base member 15. The base member may also be formed of a plastics material and has a rim 16 which has a bevel edge 16a so that when the escutcheon 10 is applied to the base member 15, the rim 11 of the escutcheon may pass over the rim 16 of the base plate and the lower edge of the rim 11 of the escutcheon will snap under the bevel edge 16a so that the escutcheon 10 will be firmly attached to the base plate 16.

It will thus be understood that any information that may be written on, placed on or inscribed on the obverse face of the display member 12 will then be housed and

so protected between the escutcheon 11 and the base member 15. Since the escutcheon 10 is formed of a transparent material, the indicia displayed on the face of the display member 12 will be readily visible.

Various methods of attaching the indicator to a surface such as that indicated at 20 may be utilized. One method comprises forming a mounting hole 21 in the base member 15 through which a screw such as that indicated at 22 may be passed. If the surface 20 is of a material that will accept a screw, then the screw 22 can be screwed directly into the surface 20. If the composition of the surface is such that the screw cannot be directly screwed into the surface, then a hole 23 can be first formed which may or may not be tapped to receive the threaded shank of the screw which in such a case can be a machine screw rather than the wood type screw indicated at 22. Another method of attaching the base plate to the surface 20 may consist, for instance, in forming a hole 23 in the surface and then placing within the hole a suitable sleeve such as that indicated at 24 with the sleeve having an axial hole as indicated in the drawings. If the sleeve is formed of a suitable composition, the screw 22 can be screwed directly into the axial hole in the sleeve 24.

Another method of attaching the indicator to a surface consists in utilising a suitable adhesive in conjunction with the base member 15. Various forms of adhesives can be utilized and one preferred form comprises an air curing epoxy adhesive. Preferably the adhesive is spread onto a suitable sealing member 31 and the adhesive is located between a second sealing member 32. One form of composition of the sealing members 31 and 32 may be a metal or a metal foil or an air impervious plastics material so that after the adhesive has been placed on the sealing member 31, the sealing member 32 can be placed to cover the adhesive and the first sealing member 31. The edges of the two sealing members 31 and 32 are then suitably adhered to each other to retain the adhesive out of contact with the air.

The sealing member 32 may be permanently attached, such as by additional adhesive indicated at 33, to the underside of the base member 15. Preferably the

underside of the base member 15 is rebated as at 15a to accommodate the adhesive and to enable a minimum gap to exist between the base member 15 and the surface 20 after the base member has been adhered to the surface. Immediately prior to the application of the indicator device to the surface 20, the seal member 31 can be removed to expose the adhesive 30 which will then enable the base member 15 to be placed on and thus adhered to the surface. Either prior to or subsequent to the adhering of the indicator device to the surface, indicia can be inscribed on the display member which is placed on the base member and the escutcheon 10 can then be attached to the base member 15.

Preferably a series of spikes or similar protuberances 31 (see Fig 3) project from the reverse face of the base member with the protuberances being so formed that when the base member has been placed on a surface to which the indicator device is to be secured, the protuberances will engage on the said surface to assist in resisting movement of the indicator device on the said surface.

In a modification of the invention, instead of utilizing a display member 12 on which the indicia is displayed, the display member can be in the form of a self-adhesive label. In this form, part or all of the obverse face of the label can be coated with the adhesive which will normally be protected by a release sheet. By removing the release sheet the label can then be adhered directly to the underside of the escutcheon thereby substantially eliminating the possibility of condensation occurring between the escutcheon and the label.

While the indicator device as herein described is of a disk formation, in that it is essentially circular in outline, the indicator device can be manufactured in any other desired shape such as a polygonal shape or any suitable geometric or non-geometric shape.

The indicator device as herein described can have many uses. For instance it can mark the presence of underground services for ready identification by utility field

workers, contractors and the like. The indicator device can, by reason of the arrow and other indicia on the visible face, also provide an accurate indication as a back up to, for instance survey plans.

The indicator device itself can be reflectorized and or the indicia displayed by the device can be reflectorized to aid identification and interpretation at night.

Because of the form of the indicator device, although it is simple to assemble and be located at the desired place, it will be difficult to illegally remove the device from the site because the fixing device is not accessible. In addition, since the indicator device can be constructed from for instance a tough plastics material, high resistance is provided against damage by accident or deliberately such as by vandalism. The plastics material can also be chosen so the indicator device will resist deterioration by the effects of weather, such as sun, rain and wind and in this regard to comparatively smooth exterior will resist the accumulation of dirt and dust when the indicator device is exposed to the weather.

To assist ready identification, all or part of the visible face of the indicator device can be coloured or colour coded.

While the above description relates to a preferred form of the invention it is to be understood that various modifications and alterations to the invention particularly as the size, shape and constitution of the materials is concerned may be made as will be apparent to those skilled in the art.

CLAIMS

1. An indicator device consisting of:
 - a substantially planar base member having an obverse face, a reverse face and a peripheral edge,
 - a substantially planar escutcheon having a peripheral skirt to engage over the peripheral edge of said base member and to be located over the said obverse face of the base member, with at least a portion of the escutcheon being substantially transparent,
 - a display member adapted to be positioned between the obverse face of said base member and the substantially transparent portion of the escutcheon, said display member having a face to receive and display indicia,
 - means associated with the said base member to enable the said base member to be secured to a surface.
2. The indicator device as claimed in claim 1, wherein the means associated with the base member to enable the base member to be secured to a surface comprises at least one hole formed through the base member.
3. The indicator device as claimed in claim 1, wherein the reverse face of the base member is rebated to form a cavity to receive an adhesive to enable the said base member to be adhered to said surface.
4. The indicator device as claimed in claim 4, wherein a first sealing member is adhered to the reverse face of the base member and wherein adhesive is positioned on the said first sealing member and is covered by a second removable sealing member.
5. The indicator device as claimed in claim 1, wherein the display member comprises a substantially planar sheet and is adapted to receive indicia on an observe face which when the escutcheon has been positioned on the base member, will be

visible through said transparent portion of the escutcheon.

6. The indicator device as claimed in claim 1, including means projecting from the reverse face of said base member and adapted to contact the said surface on which the base member is located.

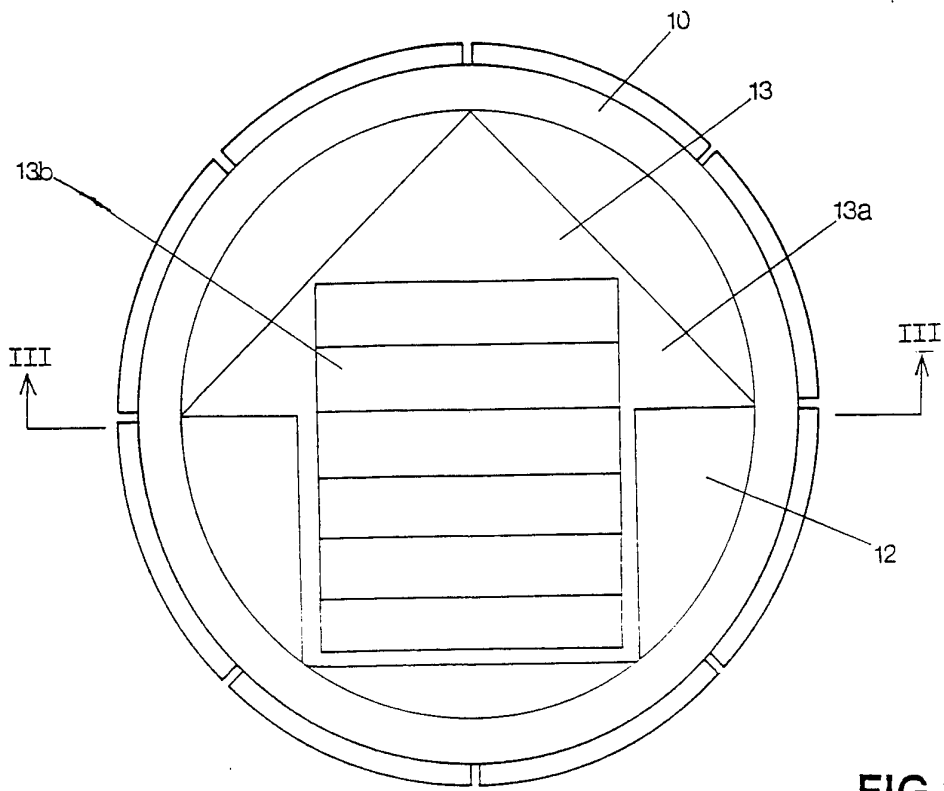

FIG 1

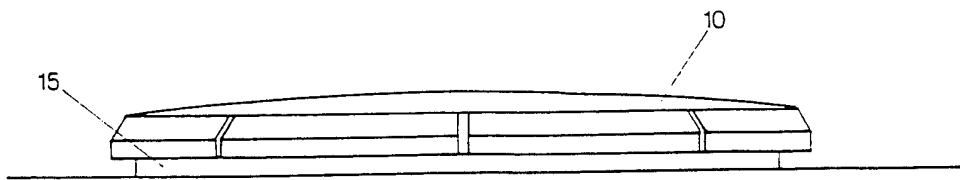

FIG 2

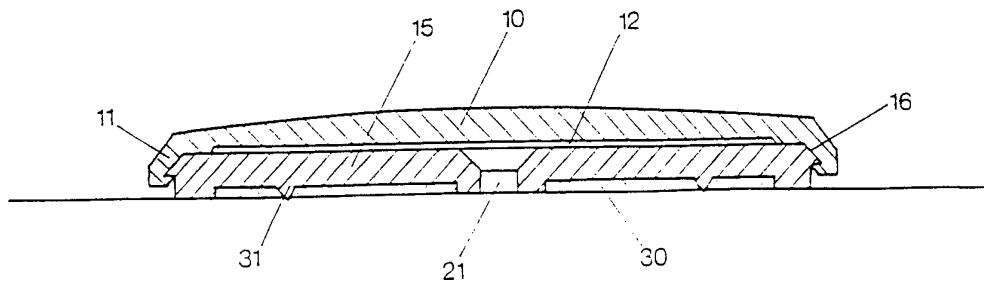
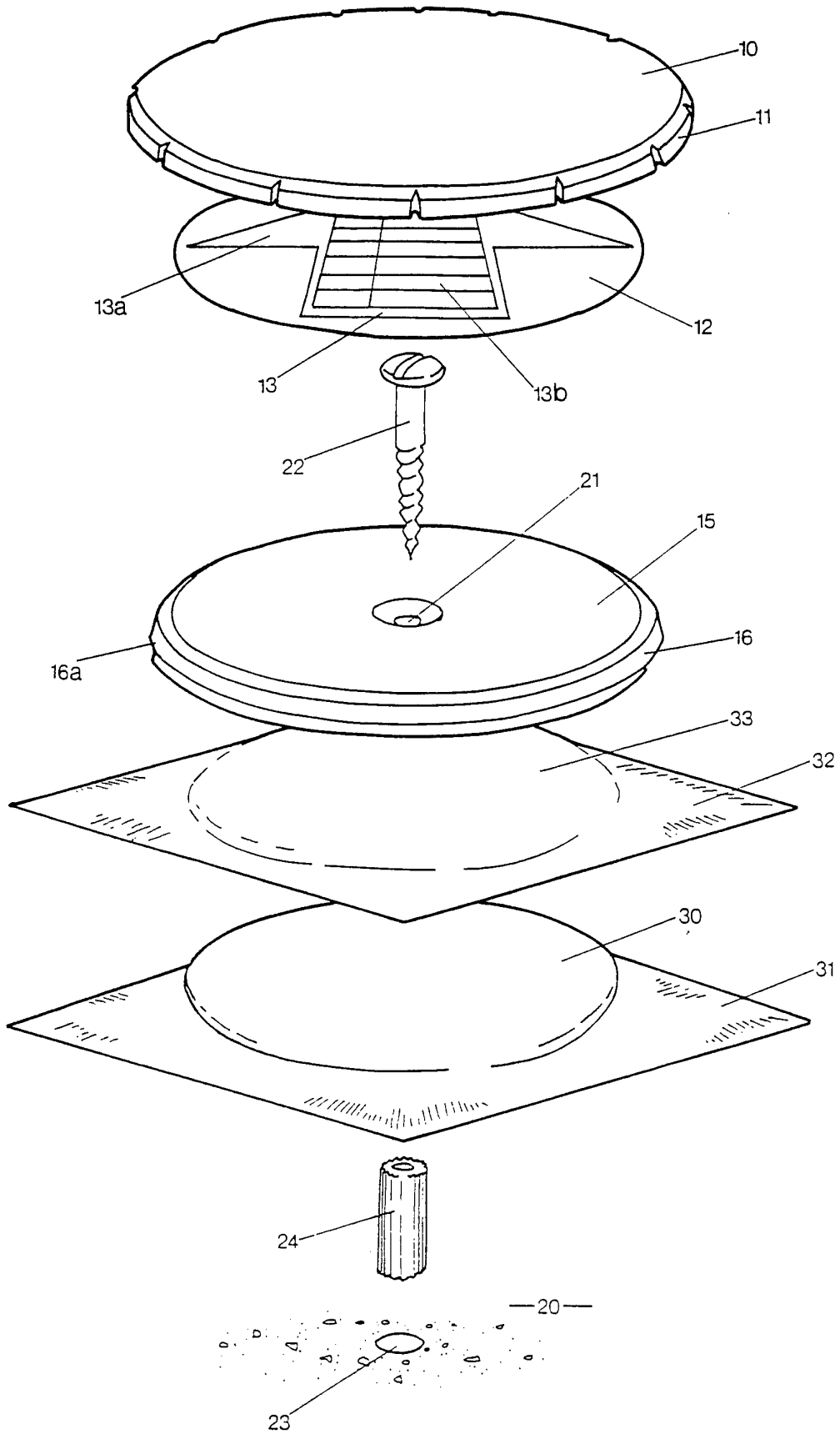

FIG 3

FIG 4



INTERNATIONAL SEARCH REPORT

International application No.

PCT/NZ 94/00141

C(Continuation). DOCUMENTS CONSIDERED TO BE RELEVANT		
Category*	Citation of document, with indication, where appropriate of the relevant passages	Relevant to Claim No.
X	GB 1527263 A (J.F. KENURE LIMITED) 4 October 1978 whole document	1
X	US 3407523 A (WINSTON) 29 October 1968 whole document	1,2,5
X	GB 528363 A (BECKER) 28 October 1940 whole document	1
A	FR 1243934 A (HOLOPHANE) 12 September 1960 Fig 3	1
A	AU 105474 A (BRITISH DUPLEX SEALS LIMITED) 12 October 1938 Fig 2	1
A	GB 360761 A (WALTON) 12 November 1931 whole document	1
A	AU 9045/27 (MALONYAY) 17 January 1928 Figs 1 and 2	

