

(No Model.)

H. F. DUNHAM.
WATER OR GAS MAIN.

No. 481,935.

Patented Sept. 6, 1892.

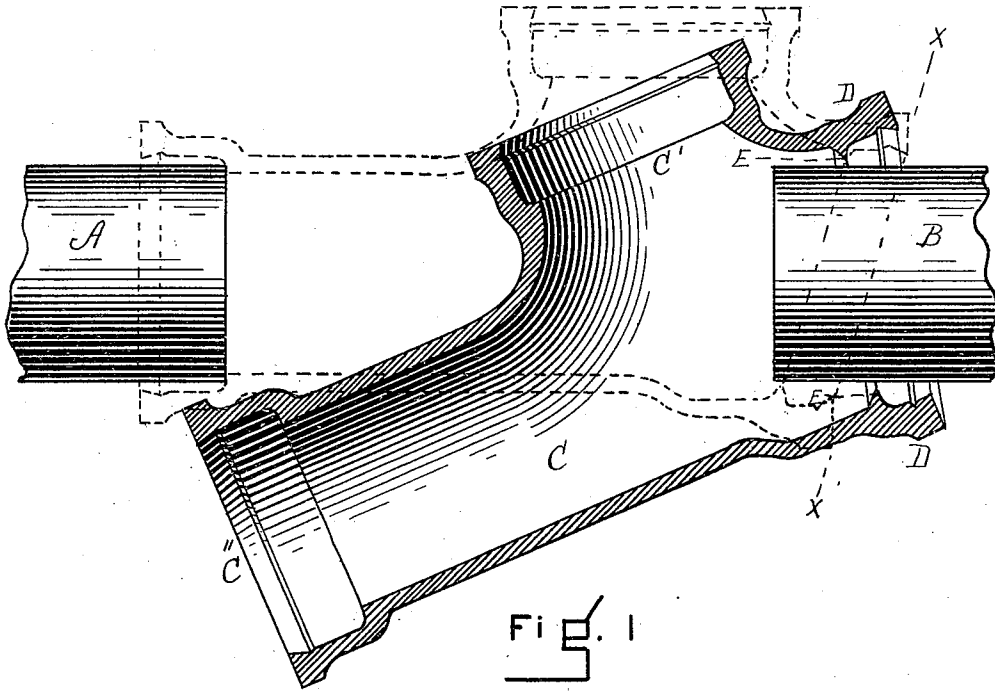

FIG. 1.

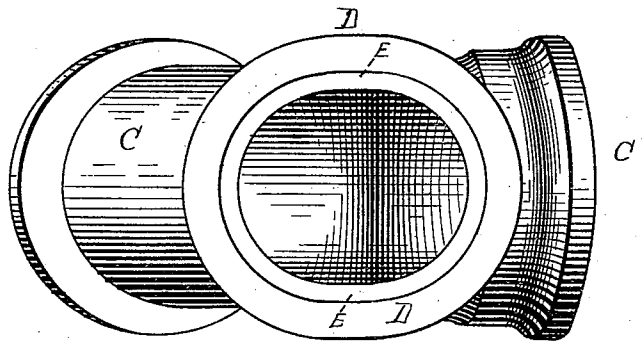

FIG. 2.

WITNESSES.

L. H. Smith
B. M. Williams

INVENTOR

Herbert F. Dunham,
By his Atty
Sherry Williams

UNITED STATES PATENT OFFICE.

HERBERT F. DUNHAM, OF NEW YORK, N. Y.

WATER OR GAS MAIN.

SPECIFICATION forming part of Letters Patent No. 481,935, dated September 6, 1892.

Application filed February 24, 1892. Serial No. 422,601. (No model.)

To all whom it may concern:

Be it known that I, HERBERT F. DUNHAM, of the city, county, and State of New York, have invented new and useful Improvements in Water or Gas Mains, of which the following is a specification.

It often happens in the maintenance of a water or gas distributing system that branches for new streets or new hydrants or other uses have to be put into the original lines of pipes. The ordinary method of accomplishing this requires the employment of three different pieces—viz., the branch or T, a short piece of common pipe, and a sleeve of larger diameter reinforced at each end to furnish opportunity for calking, said sleeve being passed on over one of the newly-cut ends of the new pipe to be moved forward after the other pieces are in position, in order to secure the last joint. The method or practice is to cut away a portion of the main pipe, slip the sleeve on over one of the cut ends, put the branch and short piece in place, and then move the sleeve forward into its final position. The four joints thus produced are then yarned, leaded, and calked or otherwise made secure. The above method requires considerable excavation, and it is often troublesome to support all the different pieces in position while the work is being done. My improvement does away with the use of the sleeve and the short piece of pipe, and thus reduces the number of joints to two and the number of pieces to one—viz., the branch or T (often called a "special") which is to be applied.

My invention relates, therefore, particularly to the construction of the improved branch or special, fully described below, and while this special is more particularly adapted for use in connection with gas and water mains I do not confine myself to its application to these systems, as it may be of use in connection with vitrified or sewer and drain pipes.

In the accompanying drawings, in which similar letters of reference indicate like parts, Figure 1 is a horizontal section of my improved special or branch in the position assumed while it is being moved into place over the ends of the main, which are shown in plan. The special is shown in broken lines

in its final position. Fig. 2 is an elevation, the plane of which is parallel to the oblique face of the branch or special, as indicated by broken line *x*, Fig. 1.

A B represent the adjacent ends of the main over which the special is to be placed, a portion of said main having been cut out to receive it.

C is the special or T or branch, the branch proper being shown at C'. One end of this special, which for the sake of convenience I will term the "rear" end, is provided with an ordinary bell C''. The other end or front end is constructed in the following manner:

First. Its bell D is enlarged horizontally into the shape of an ellipse, as shown in Fig. 2. In other words, while in vertical section its diameter need be little or no greater than that of the bell C''. Its oblique diameter in horizontal section is decidedly greater, as shown in both Figs. 1 and 2.

Second. The face of the enlarged bell end D is beveled off, so as to be at an oblique instead of a right angle with the axis of the special, thus bringing the outer end of the bell at one side of the special nearly opposite the inner end or bottom of the bell at the other side.

Third. The inner surface of this bell D is provided with an oblique bead or rib E, which is also of the elliptical shape shown in Fig. 2.

Fourth. The branch or side opening C' is not located centrally in the special, but is set near the enlarged end or bell D.

To place the special in position, the enlarged end is first placed over the end of the portion B of the main and the special moved forward. Afterward the opposite end or bell C'' is moved laterally and backward and placed over the end of the portion A of the main, as shown in broken lines, Fig. 1. The horizontal enlargement of the bell D, so that that end is elliptical in shape, is to permit the entrance of the pipe B and its admission to a point far enough back of the usual shoulder to allow the opposite end C'' to swing into a position from which it can be carried back and slipped over the end A of the main pipe. The beveling of the enlarged end B, so as to bring it into an oblique angle with the axis of the special, is for the purpose of allowing

greater amplitude of the horizontal movement while the special is being placed into position. The oblique bead or rib E, which passes over the end B of the main during the process of applying the special, comes so nearly in contact with said special after it is in position as to form a stop against which the yarn can be driven before the joint is completed or before the lead is introduced. Of course the office of its oblique shape and elliptical form is the same as that of the similar shape and form of the bell D.

The object of locating the branch or side opening C' near the enlarged end D is to provide space for the required movement of the special upon or about the end of the pipe B while said special is being placed in position. In other words, thus locating the branch avoids necessity of forming a pocket or auxiliary chamber in the special for the accommodation of the end of the pipe B during the process of applying the special or T.

It is obvious that by enlarging one end of a special sufficiently it could be slipped on over the end of the main pipe far enough to permit the special to be moved into position; but in such a construction the space around the end of the main would be too great to insure good work unless the length of the special were so great that there would be no economy over the old method. By combining the enlargement with the beveled end the space between the bead or rib E and the pipe B, while great enough to accommodate the movement of the special, is gradually diminished as the special is being brought into position, becoming eventually very slight and of even width around the main.

The method of or materials used in packing or otherwise rendering tight the joints needs no detailed description, as it may be modified as desired.

It will be observed that the special is decidedly enlarged just back of the bell, this being an enlargement of the body of the special rather than the bell, for the accommoda-

tion of the end of the main while the parts are being placed in position.

This improvement is applicable not only to a T—*i. e.*, a special with one branch, as shown—but to a “cross”—*i. e.*, a special with opposite branches. Moreover, the invention is applicable to a “gate” as well as a special, and it is my intention to use the same in both connections.

Having thus fully described my invention, what I claim, and desire to secure by Letters Patent, is—

1. In a pipe system of the character described, a special or branch, as C, one of whose bell ends is enlarged horizontally, so that its diameter in horizontal section is greater than its diameter in vertical section, said special being provided with a branch or side discharge-opening C' near said enlarged bell end, whereby space is provided for the end of the main pipe during the application of the special without recourse to a pocket, substantially as described.

2. In a pipe system of the character described, an enlarged bell end, as D, whose face or end is beveled off at an oblique angle with the axis of the special, substantially as described.

3. In a pipe system of the character described, an enlarged bell end, as D, provided on its inner surface with the oblique bead or rib E, substantially as set forth.

4. In a pipe system of the character described, the special or branch herein specified and consisting, essentially, of the round pipe C, provided with the ordinary round bell end C', the enlarged elliptical bell end D, having an oblique face, as described, the oblique bead or rib E, and the branch or side discharge-opening C', placed near the enlarged bell end, substantially as specified.

HERBERT F. DUNHAM.

Witnesses:

JOSEPH FLESHIEM,
HENRY W. PACKER.