



INTERNATIONAL APPLICATION PUBLISHED UNDER THE PATENT COOPERATION TREATY (PCT)

| | | |
|---|---|---|
| (51) International Patent Classification ⁶ : G01B 11/22, 21/18 | A1 | (11) International Publication Number: WO 96/10727 |
| | | (43) International Publication Date: 11 April 1996 (11.04.96) |
| <p>(21) International Application Number: PCT/GB95/02340</p> <p>(22) International Filing Date: 3 October 1995 (03.10.95)</p> <p>(30) Priority Data: 9418091.6 3 October 1994 (03.10.94) GB</p> <p>(71)(72) Applicant and Inventor: RUSSELL, Malcolm, Brian [GB/GB]; 27 Claymoor Park, Marlow, Buckinghamshire SL7 3DZ (GB).</p> <p>(74) Agent: LYND, Michael, Arthur; Edward Evans & Co., Chancery House, 53-64 Chancery Lane, London WC2A 1SD (GB).</p> | <p>(81) Designated States: AM, AT, AU, BB, BG, BR, BY, CA, CH, CN, CZ, DE, DK, EE, ES, FI, GB, GE, HU, IS, JP, KE, KG, KP, KR, KZ, LK, LR, LT, LU, LV, MD, MG, MN, MW, MX, NO, NZ, PL, PT, RO, RU, SD, SE, SG, SI, SK, TJ, TM, TT, UA, UG, US, UZ, VN, European patent (AT, BE, CH, DE, DK, ES, FR, GB, GR, IE, IT, LU, MC, NL, PT, SE), OAPI patent (BF, BJ, CF, CG, CI, CM, GA, GN, ML, MR, NE, SN, TD, TG), ARIPO patent (KE, MW, SD, SZ, UG).</p> <p>Published <i>With international search report. Before the expiration of the time limit for amending the claims and to be republished in the event of the receipt of amendments.</i></p> | |

(54) Title: TYRE SCANNING APPARATUS AND METHOD

(57) Abstract

The present invention provides apparatus (1) for determining physical characteristics of a tyre (14, 27) mounted on a wheel (16) fitted to a vehicle (17, 30), which apparatus comprises scanning means (5) adapted to scan a tyre (14, 27) and to produce an output indicative of information relating to tread depth, and indicator (21, 22, 34) means responsive to the output of the scanning means to provide an indication of tread depth. The invention also provides a method for determining physical characteristics of a tyre, which method comprises scanning a tyre (14, 27) mounted on a wheel (16) fitted to a vehicle (17, 30) and producing therefrom an output indicative of information relating to tread depth, and providing from said output an indication of tread depth. Preferably the invention employs a laser or ultrasonic sensor and includes means (18, 19; 35, 36) whereby the tyre may be rotated during scanning. The invention may employ image-capture means to capture an image of a region of the tyre under inspection.

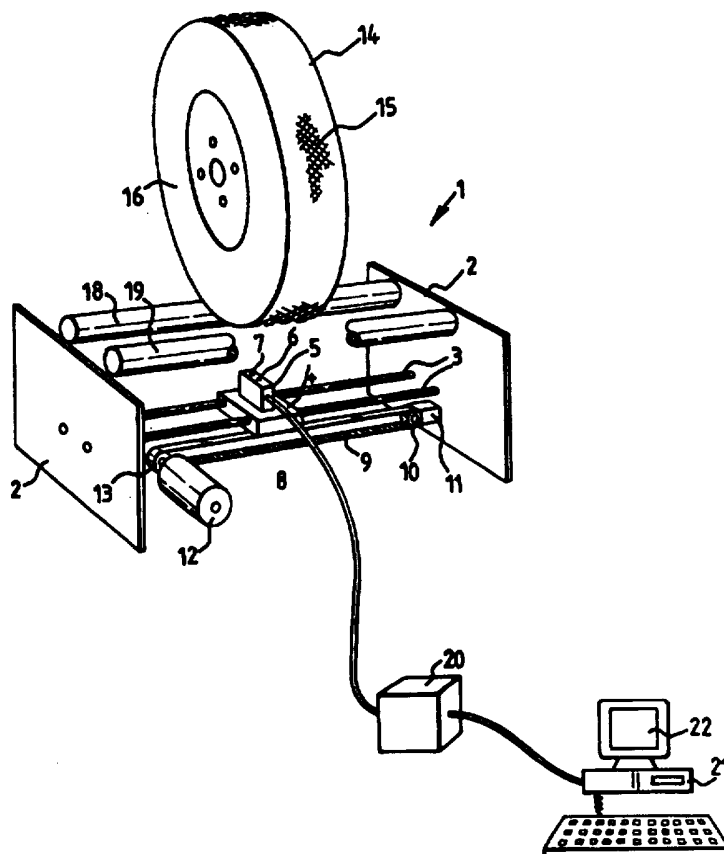

FOR THE PURPOSES OF INFORMATION ONLY

Codes used to identify States party to the PCT on the front pages of pamphlets publishing international applications under the PCT.

| | | | | | |
|----|--------------------------|----|--|----|--------------------------|
| AT | Austria | GB | United Kingdom | MR | Mauritania |
| AU | Australia | GE | Georgia | MW | Malawi |
| BB | Barbados | GN | Guinea | NE | Niger |
| BE | Belgium | GR | Greece | NL | Netherlands |
| BF | Burkina Faso | HU | Hungary | NO | Norway |
| BG | Bulgaria | IE | Ireland | NZ | New Zealand |
| BJ | Benin | IT | Italy | PL | Poland |
| BR | Brazil | JP | Japan | PT | Portugal |
| BY | Belarus | KE | Kenya | RO | Romania |
| CA | Canada | KG | Kyrgystan | RU | Russian Federation |
| CF | Central African Republic | KP | Democratic People's Republic of Korea | SD | Sudan |
| CG | Congo | KR | Republic of Korea | SE | Sweden |
| CH | Switzerland | KZ | Kazakhstan | SI | Slovenia |
| CI | Côte d'Ivoire | LI | Liechtenstein | SK | Slovakia |
| CM | Cameroon | LK | Sri Lanka | SN | Senegal |
| CN | China | LU | Luxembourg | TD | Chad |
| CS | Czechoslovakia | LV | Latvia | TG | Togo |
| CZ | Czech Republic | MC | Monaco | TJ | Tajikistan |
| DE | Germany | MD | Republic of Moldova | TT | Trinidad and Tobago |
| DK | Denmark | MG | Madagascar | UA | Ukraine |
| ES | Spain | ML | Mali | US | United States of America |
| FI | Finland | MN | Mongolia | UZ | Uzbekistan |
| FR | France | | | VN | Viet Nam |
| GA | Gabon | | | | |

TYRE SCANNING APPARATUS AND METHOD

This invention relates to apparatus for determining physical characteristics of a tyre and to a method of determining physical characteristics of a tyre. The invention is particularly useful for determining the depth of tread remaining on a tyre and/or for detecting defects in a tyre. The invention enables tyres to be scanned *in situ*, that is to say when mounted on a wheel or rim fitted to a vehicle.

According to a first aspect of the present invention there is provided apparatus for determining physical characteristics of a tyre mounted on a wheel fitted to a vehicle, which apparatus comprises scanning means adapted to scan a tyre and to produce an output indicative of information relating to tread depth, and indicator means responsive to the output of the scanning means to provide an indication of tread depth.

According to a second aspect of the present invention, there is provided a method for determining physical characteristics of a tyre, which method comprises scanning a tyre mounted on a wheel fitted to a vehicle and producing therefrom an output indicative of information relating to tread depth, and providing from said output an indication of tread depth.

In order for the scanning means of the apparatus of this invention to scan a tyre, the scanning means may be driven across the width of the tyre, e.g. by means of an electric motor. Alternatively, or as well, the tyre itself may be moved transversely of the scanner and/or may be rotated relative to the scanner. In other embodiments the scanning means may include a sufficient number of scanner devices, which may be of the same or different type, or a

sufficiently wide scanning head to scan the width of the tyre without a requirement for relative movement between the apparatus of this invention and the tyre. In yet other embodiments a movable mirror may be used to scan the tyre.

Any suitable scanning means may be employed in the apparatus of this invention. Thus for example electromagnetic radiation, e.g. continuous or pulsed laser light, may be directed onto the tyre and a reflection of that radiation detected to provide tread depth information. In other embodiments high frequency, e.g. ultrasonic, sound may be reflected from the tyre surface to provide tread depth information. It is envisaged that other scanning means may be used, such as, for example, the direction onto a tyre of one or more hydraulic or pneumatic jets, with variations in jet pressure (either reflected pressure or back pressure) being measured to obtain tread depth information, or that, for example one or more metal detectors could be used to derive tread depth information, e.g by measuring the changes caused by tread depth variation, in the strength of a signal resulting from the presence of metal in the tyre. (In one embodiment of the scanning apparatus of the present invention, a succession of scanning means are arranged to lie beneath, e.g., in the case of an optical scanning means, underneath a panel of transparent material, a path of travel of a tyre to be tested; as the vehicle drives along said path, the successive scanning means scan the region of the tyre presented to the successive scanning means to provide the requisite tread depth information. Where non-optical scanning means are employed, the scanning means may be embedded in the surface over which the tyre passes.

In a preferred embodiment, pulses of visible or invisible laser light are directed on to the tyre surface and the reflections of those pulses from the tyre

tread detected, the time delay in receiving the pulses being used to derive an indication of tread depth in respect of the tyre.

In another embodiment, visible light reflected from the surface of the tyre, e.g. from an obliquely arranged light source, is recorded, e.g. by means of a charge couple device (CCD), CMOS, video camera or the like, the image then digitized, converted to, e.g., a grey scale, and the shades of grey used to provide an estimate of tread depth. The visible light employed may be ambient light but preferably in these embodiments the apparatus includes a light source providing a light output of known intensity and known spectral properties. It will of course be possible to provide means for varying the intensity of the light source or, e.g. by means of suitable filters, to vary the spectral properties of the light.

It will be understood that if a CCD, CMOS or camera is used, whether as the scanning means or as an adjunct to the scanning means, the CCD, CMOS or camera may be arranged to produce an actual image of the tyre tread or a portion thereof, which image may be printed or stored in any suitable storage means, such as digitally on hard or floppy disk.

In yet another embodiment, a stereoscopic image of the tyre tread is obtained, e.g. by use of a pair of spaced cameras or lenses, and information derived from the stereoscope image (e.g. length of shadows, etc.) in respect of tread depth.

Although in a simple embodiment there may be no need to obtain tread depth information from more than one region of the tyre, in general it is desirable to obtain tread depth information for some or all of the tyre's circumference. Although the apparatus of this invention may be arranged to rotate about the

tyre, it is more convenient to provide means for rotating the tyre to present different regions of the tyre's circumference to the apparatus of this invention for scanning. Such tyre rotation means may comprise a pair of rollers for receiving and supporting a tyre mounted on a wheel and fitted to a vehicle, one or both of the rollers being drivable in rotation to rotate the tyre. It is to be understood that the apparatus of this invention may be fitted, retro-fitted or installed in other vehicle maintenance or inspection equipment, such as for example a vehicle lift or hoist or a vehicle brake-testing apparatus such as a rolling road, or a weighbridge. In such circumstances, it will may be possible to use the wheel rotation facility provided in that other apparatus, provided always of course that means can be provided to ensure that the tyre/wheel can be rotated at a speed suitable for the apparatus of the present invention.

The output of the apparatus of the present invention will most suitably be in the form of an electric signal, the voltage of which is proportional to tread depth. If analogue, this signal may be converted to a digital signal and then passed e.g. to a computer and VDU for processing and display.

The indicator means responsive to the output of the scanning means need not of course be a computer and VDU and any suitable indicator means may be employed. In a simple case the indicator means may be no more than a PASS/FAIL indicator, indicating for example whether or not the depth of tread remaining at one region of the tyre is sufficient to comply with applicable law. In other embodiments the display may show a profile of the tyre to reveal tread depth variations, or may indicate deviations from a standard tread pattern. The indicator means may be audible rather than visible, e.g. to provide a pleasing sound intended to indicate a PASS, and a loud, unpleasant noise intended to indicate a FAIL.

Furthermore, successive tread scans may be compiled to build a virtual 3-dimensional image of the tyre, which image may for example be mapped by suitable software onto an image of a torus to create a picture of a tyre and may for example be rendered in false colours to provide easily visible depth information. Thus, for example, parts of the tyre which have satisfactory tread depth might be indicated in green while other parts of the tyre which do not have satisfactory tread depth might be indicated in red.

An advantage of using a computer as the indicator means of this invention is that the information derived from the scanner means may be manipulated and processed in many different and useful ways. Thus, for example, it may be possible to 'zoom in' on a specific region of the tyre for a detailed inspection of that region; it may also be possible to rotate on screen a 3-dimensional image of the tyre or of a region of the tyre to examine it from different aspects. It may also be possible to alter the relative scaling of the image to provide, for example, an image with exaggerated depth of tread as compared to overall tread width.

In a preferred embodiment of the present invention, a tyre mounted on a wheel fitted to a vehicle is rotated over or in front of a scanning apparatus according to the present invention. A computer associated with the scanning apparatus is programmed to obtain data from the scanning means in respect of the tyre tread and to process that data. Specifically, the program is provided with predetermined maximum and minimum permissible tyre circumferences. The rotating tyre is scanned and data is obtained for the entire width of the tyre and for several circumferential rotations of the tyre. The software then scans through the data to find one or more identifiable marks, tread depth anomalies or other unique identifiers on the tyre

circumference. Using this identifier or set of identifiers the program then scans the collected data to find one or more repetitions of that identifier or set of identifiers. Having achieved this, the program then checks that the circumferential distance between the repeated identifier or set of identifiers is within the maximum and minimum permitted tyre circumferences. If the circumferential distance is between those limits then that circumferential distance is taken as the circumference of the tyre. The software then processes the data to obtain tread depth information for a complete revolution of the tyre, i.e. for one circumference of the tyre to check whether the tread depths measured comply with preprogrammed legal criteria. For example, in the case of the United Kingdom, the central 75% of the width of the tyre tread must have a tread depth of at least 1.6mm about the entire circumference of the tyre. The software compares the tread depth information derived from the data collected with the preprogrammed criteria and indicates by suitable means whether the tyre complies or not with the legal requirements.

The apparatus of the present invention may be capable not only of providing tread depth information but also of providing other information about the condition of the tyre. Thus, the apparatus of this invention may be adapted to reveal bulges in a tyre wall, nicks or notches in a tyre wall, uneven wear caused by over-inflation, under-inflation, or vehicle suspension and/or steering geometry set-up errors. Indeed the apparatus of this invention can under certain circumstances be used as a diagnostic tool for assessing the correctness of such suspension and/or steering geometry set-up.

The apparatus and method of the present invention may also be used to measure other tyre parameters such as, for example, overall concentricity of the tyre, or whether a side wall of the tyre lies adequately in or about a single

plane. For this purpose it may be necessary to drive the wheel in rotation by means other than rollers bearing upon the tyre itself, for example by driving the wheel in rotation by a force applied to the wheel rim or to the axle of the wheel, with the tyre out of contact with the ground or any other surface imposing load upon the tyre itself.

The apparatus of this invention may also, for example, include detection means for detecting the presence of metal, thus to reveal, for example, whether or not the tyre has picked up a nail. Such detection means may employ an induction loop for detecting the presence of metal.

If a computer is used to process the results of the scanning, then other data manipulation also becomes possible. For example, on a conventional tyre, the tread pattern repeats about the circumference of the tyre at fixed intervals, normally of 2 or 3 centimetres in the case of a tyre for a private car. Thus, by examining only a few regions of the tyre (preferably at non-uniformly spaced locations about the tyre, the overall tread pattern of the tyre may be determined, since differences in tread depth will not significantly affect the tread pattern. Once the repeat of the tread pattern has been identified (which may, as will be recognised by one skilled in the art, be simply achieved by means of appropriate software) the repeat can then be compared with other sections of the tread about the circumference of the tyre to reveal gross differences between the portions of tread being compared such as the presence of a bald patch, a piece of glass, a stone or a nail.

The inventor recognises that it may be useful to have a database of common tyre tread patterns for tread identification and comparison purposes, and to provide information which may be used for marketing and other purposes.

For example, it is illegal in the United Kingdom to drive a car on a public highway with certain combinations of radial and cross-ply tyres; the ability automatically to identify a tyre by its tread and thus to determine rapidly whether it is radial or cross-ply is of great value to the police, garages and others in assessing the legality of any particular combination of tyres present on a vehicle. Again, on trucks and heavy goods vehicles, it is fairly common to find tyres of different sizes (diameter or width) being employed at the same time. The apparatus of the present invention makes it possible readily to identify the individual tyres present on the vehicle and thus to determine whether the tyres meet legal requirements.

For marketing purposes, for example, the apparatus of the present invention can, subject to the requirements of the United Kingdom Data Protection Act 1984, provide tyre sellers and manufacturers, and car manufacturers, with useful information about tyre popularities, by type of vehicle, by geographical region, etc. In conjunction with information relating to the vehicle (e.g. age of vehicle, year of registration, mileage, body type, company/ personal car and date of last test/inspection) and/or the address of its registered owner/keeper, it is possible for the police and others to send out reminders of the need to replace tyres at intervals calculated from knowledge of the make of the tyres, of tyre wear rates and of the condition of the tyres on the vehicle.

The scanning apparatus may also include recorder means, e.g. one or more of a video camera, a still camera or digital storage device (e.g. a hard disk, floppy disk, magneto-optical disk or CD-Rom), and printout means to provide a permanent record, e.g. on paper or on floppy disk, of a tyre and/or of the vehicle to which the tyre is fitted, which record may be in a form suitable for use e.g. by the police for evidentiary purposes.

The scanning apparatus of this invention may be adapted also to measure the gross dimensions of the tyre under test, for example the circumference (and hence the radius and diameter) of the tyre and its overall width, in order to facilitate a more rapid and accurate identification of the tyre under test by reference to a tyre tread database, which database may be present either in an adjacent computer or in a remote computer accessible by modem, by digital telephone or by any other suitable means.

The scanning apparatus of this invention may also be provided with one or more lateral support devices for supporting on the apparatus either a tyre per se or a tyre mounted on a wheel but off a vehicle. With such a tyre suitably supported, the tyre rotation means may drive the tyre in rotation to enable scanning of the tyre. It is to be appreciated that such lateral support devices are adjuncts to the apparatus of the present invention. Suitable support devices include simple guide elements positionable to support the tyre in an upright position, and guide elements equipped with one or more rollers or other low-friction contact devices to support the tyre in an upright position and yet permit rotation of the tyre, and means for supporting and rotating a tyre about a vertical axis.

The apparatus of the present invention may include ancillary means for viewing one or both of the sidewalls of a tyre to enable an assessment to be made of the condition of the or each sidewall and to view information present on one or both of the sidewalls of a tyre under test, e.g. the maker's name, the tyre dimensions, the recommended pressures, the recommended use to which the tyre is to be put, the construction of the tyre, etc. For example, such ancillary means may include one or more scanning means as discussed above, the output of said scanning means being delivered to a processor able to

subject the output to optical character reading (OCR) thereby to read that information and input it into a database or to print out the information in conjunction with the tyre tread scan.

The apparatus of this invention may also include weight-measuring means to determine the weight applied to the wheel by the vehicle and its load. In conjunction with information that may be obtained from the scanning means about the area of tyre in contact with the ground (the 'footprint' of the tyre) it may be possible to calculate a numerical value for the tyre pressure. This calculated tyre pressure may be compared with a database of known or recommended tyre pressures for specific tyre and/or vehicle combinations to provide an indication of whether the tyre is currently over- or under-inflated.

An embodiment of the scanning apparatus of the present invention will now be described, by way of example only, by reference to the accompanying drawings, in which:

Fig 1 is a diagrammatic view of the elements of an embodiment of apparatus according to the present invention;

Fig 2 is a 2-dimensional plot of the results of scanning a tyre;

Fig 3 is a further 2-dimensional plot of the results of scanning a tyre;

Fig 4 is a 3-dimensional plot of the results of scanning

a tyre;

Fig 5 is a mapping of 3-dimensional tyre tread depth data onto a torus;

Fig 6 is a photograph of a region of a tyre which includes both a stone and a nail in its tread;

Figs 7a to 7e are diagrammatic illustrations of different tyre wear anomalies that may be detected and/or diagnosed by means of embodiments of the present invention;

Fig 8 is a perspective view of an embodiment of apparatus according to the present invention in the form of a 'drive through' system, with a vehicle in a preliminary position;

Fig 9 is a second illustration of the embodiment of the apparatus according to the present invention which is shown in Fig 8, with the vehicle in place for its front tyres to be scanned;

Fig 10 is an illustration of another embodiment of apparatus according to the present invention, suitable for installation in, e.g., a garage or petrol filling station environment; and

Fig 11 is an illustration of another embodiment of apparatus according to the present invention, in a form capable of easy assembly and disassembly for road-side use by the police for conducting spot-checks on tyre condition.

Referring to the drawings, and particularly to Fig 1, there is shown an embodiment of apparatus 1 according to the present invention. The apparatus 1 consists of a frame 2 supporting a pair of slide rods or bars 3. Mounted on the slide rods or bars 3 is a support 4 carrying a 12 volt laser analog sensor 5. This sensor 5, which in this embodiment is one available from Matsushita Electronics Inc. as part No. NAIS ANL1451RE, consists of a laser 6 adapted to emit pulses of red light and a detector 7 for receiving reflected pulses. The support 4 includes a clamp 8 carrying a toothed belt 9 which extends about pulley 10 supported by bracket 11. A 24 volt electric motor 12 is provided with a drive 13 for driving the toothed belt 9 in rotation, thus to drive the support 4 and its laser analog sensor 5 along the slide rods or bars 3. The direction of rotation of electric motor 12 is controlled by suitable software to cause the support 4 to be driven back and forth along slide rods or bars 3 as required. The frame 2, slide rods or bars 3, support 4, clamp 8, belt 9, pulley 10, bracket 11, electric motor 12 and drive 13 are conveniently derived from or obtained from a conventional inkjet printer such as is available from companies such as Epson, Star Microelectronics and Hewlett Packard, whence also can be derived the desired control software for driving the support 4 back and forth along slide rods or bars 3. (It will be appreciated that any suitable software, whether derived from existing drivers or custom-written may be used for this purpose.)

A tyre 14, provided with a tread 15 is mounted on a wheel 16 and fitted to a vehicle 17 (not shown in Fig 1). The tyre 14 is positioned over laser analog sensor 5 and is supported upon rollers 18, 19. At least one of rollers 18, 19 is rotatably drivable by means of a motor (not shown) to cause rotation of the tyre 14. The tyre 14 is conveniently positioned at a distance of between 30mm and 50mm from sensor 5, although this distance will vary in accordance with the capability of the laser sensor selected for use in the invention. (In order to minimise any risk to the public or to an operative of the apparatus, the laser is preferably selected to be of a power that complies with relevant safety laws, e.g. as required by the British Health and Safety Executive. Suitable lasers are Class 1 or Class 2 lasers in accordance with British Standard BSEN 60825-1, emitting visible light.)

With tyre 14 suitably positioned over laser analog sensor 5, the apparatus is driven to cause laser sensor 5 to scan the tyre tread 15.

When the system is initially activated the electronics resets its operating memory to zero and runs a software routine which causes the motor (not shown) to rotate the tyre.

The analogue output from sensor 5 is converted to a digital signal by means of analogue-to-digital converter 20 and then passes to a computer 21 with VDU 22. The scanning may take place at a scanning speed of approximately 10cm/sec. With the laser pulsing at a rate of 1000 pulses/second and a distance to be scanned of, say, 15 to 20 cm, this provides several thousand individual measurements of the depth of the tread, with a resolution of approximately 0.7 by 0.2mm per measurement (i.e. laser spot size) and a depth accuracy of approximately 50µm. The tyre may be driven in rotation

at a constant rate equivalent to a road speed of, say, up to 5 to 7 miles per hour (224 to 312 cm/second). For the convenience of the user, it is preferred that the time taken to scan an entire tyre be no longer than approximately 90 seconds. It is to be understood that the manner and rate of rotation may be selected in accordance with the drive means employed to drive the tyre in rotation. Thus, if a stepper motor is used to rotate the tyre, the tyre may be intermittently rotated between scans effected on a momentarily stationary tyre. It is also to be understood that in other embodiments the tyre may be rotated at a rate considerably greater than is indicated above, e.g. at a rate equivalent to a road speed of approximately 25 kilometres/hour and an adequate number of individual scans still be obtained to provide a satisfactory quantity of data to enable useful tread depth information to be obtained about the tyre under test.

Information corresponding to the image scanned by the detection device is stored in the memory of the system and is analyzed to observe the tyre pattern and to identify the cyclic pattern of the tyre; when it has identified what it thinks is the pattern the system will then rotate the tyre again and this time look for variances to this pattern.

As hereinbefore, the software identifies a point on the circumference of the tyre and takes this as a datum point; all comparisons are then made relative to this point.

If a point of variance to the cyclic pattern is detected it marks this in its memory (anomaly map) as a point to investigate further, it also scans the surface at this region to measure the depth of tread pattern and records into memory the depth memory map for the total circumference of the tyre under

test.

The decision as to whether a tyre has passed or failed comes from the criteria programmed into the software based upon the law of the land where the system is used and upon judgements programmed into the system software e.g. by trade bodies, by tyre associations manufacturers, by local equivalents of the United Kingdom Department of Transport, or by other interested parties.

It is to be noted that in normal circumstances, the apparatus of this invention will be protected from environmental factors such as rain, dust, etc. by ensuring that e.g. sensitive parts of the apparatus are screened, e.g. by a glass panel or by providing a suitably; e.g. horizontally, directed air curtain.

An example of an output obtained by means of the apparatus and method of this invention is shown in Fig 2. In Fig 2, a scale factor of 1 has been used for the horizontal scale but the vertical scale has been multiplied by a factor of approximately 5. As may be seen from the output plot of Fig 2, which in this case is taken from a Dunlop DM2 205x60 R91V tyre, the tyre has along the line of scan a tread depth of not less than approximately 4mm. The results of another, similar scan are shown in Fig 3.

Successive scanning measurements may be plotted on a 3-dimensional graph or chart to build a 3-dimensional picture of the tread of the tyre. An example of such a graph is shown in Fig 4. As may be seen, the elevated portions 23 of tread 15, as well as valley portions 24 of tread 15 and also minimum tread depth indicator bars 25, are clearly visible. (These minimum tread depth indicator bars, if present, may be conveniently used to provide a depth datum

point from which to measure the tread depth variations.)

The 3-dimensional tread depth data may be mapped, e.g. by using suitable software such as 'Autocad', onto a torus to provide a clear visual indication of the tyre being scanned. An example of such a 3-dimensional mapping is shown in Fig 5, the tread shown in Fig 5 being an actual reproduction of the tread on the tyre scanned. It is possible to render this 3-dimensional mapping in false colours in accordance with the depth of tread present at any particular region of the tyre to provide an immediately recognizable indication of whether the regions of the tyre complies with applicable local law concerning minimum permissible tread depths.

As mentioned hereinbefore, the apparatus and method of the present invention may be used to detect gross anomalies in or on the tyre. The system stores in its memory the output from the scanning process and by taking samples of this is able to build-up an image of the actual tread pattern, compare various points on the tyres surface where the tread pattern is found to repeat, and detect differences in the pattern between the points. These anomalies could be bald patches, nails stuck into the surface, cut tread, uneven wear or similar defects.

Figs 6 and 7 are pertinent to these purposes. Fig 6 shows a region 26 of a tyre 27 which has embedded in it both a stone 28 and a nail 29. The presence of both the stone 28 and the nail 29 can be detected by employing in the computer 21 suitable tread identification and comparison software to draw the attention of an operative to the differences which are manifested by the presence of these intrusions. Of course, if the apparatus of the present incorporates a metal detector as discussed above then this will detect the

presence in the tyre of the nail. Fig 7, which is taken from 'Fundamentals of Motor Vehicle Technology', by V.A.W. Hillier, 4th edition, ISBN 0-7487-5016-3, indicates how different conditions can affect the state of the tread of a tyre. As shown in Fig 7a, under-inflation of a tyre will cause measurably more wear on the shoulders of the tyre than on its centre portion. This pattern of anomalous wear can be detected by the apparatus and method of the present invention and can be used to diagnose a long-term under-inflation condition. Similarly, as shown in Fig 7b, a long-term over-inflated condition of the tyre will result in relatively greater wear towards the centre of the tyre than at the shoulders of the tyre. This pattern of anomalous wear too can be detected by the apparatus and method of the present invention and can be used to diagnose such a long-term over-inflation condition. In Fig 7c, there is illustrated a condition in which the tyre has suffered asymmetric tread wear, which may well be due to the presence of excessive camber in the suspension/steering geometry of the vehicle. Once again, the apparatus and method of the present invention can detect this condition and offer a diagnosis. Fig 7d illustrates a tyre condition in which the grooves of the treads of the tyre have 'feathered edges'. This condition can be caused by an incorrect amount of toe-in or toe-out of the tyre as mounted on the vehicle and once again the apparatus and method of the present invention can detect this condition and offer a diagnosis. If by means of the apparatus and method of the present invention there be detected a condition such as that illustrated in Fig 7e (the presence of one or more bald or relatively bald spots about the circumference of the tyre), then the apparatus can suggest that this condition may be due to other defects in the vehicle, such as steering slackness, brake drum or disc wear or distortion, worn shock absorbers or dampers or road wheels inadequately balanced in rotation.

Referring now to Figs 8 and 9, there is shown an illustration for a right-hand drive vehicle of an installation employing the apparatus and method of the present invention. A vehicle 30 drives towards fixed ramps 31a and 31b, pausing to insert into slot 32 of pillar 33 a suitable coin, credit card, charge card, jetton or token, to pay for the tyre tread analysis. Acceptance of the payment is signalled to the driver on display 34 and the driver is instructed to drive the vehicle slowly forwards until the front wheels travel up ramps 31a and 31b and are supported by rollers 35 and 36. (N.B. The customer is kept informed of the systems operation at all times via a variety of output devices. These could be either a computer monitor screen, e.g. a Zenith Cruise Pad wireless-linked computer display screen, a LED or LCD display screen or moving message device or via recorded messages played to the customer at the appropriate time.) A scanning apparatus according to the present invention is located beneath and between each pair of rollers 35 and 36. Once a sensor detects that the vehicle is in the correct position, the rotation of the wheels and the scanning of the tread of the tyre is effected. Once this has been completed the driver is instructed to drive the vehicle forwards again to position the rear wheels in a position on the rollers suitable for scanning. The scanning process is then once more carried out. Once the scanning is complete, the results are processed and analyzed and a printout of the results is produced, in readily understandable form and presented by means of slot 37 in pillar 38 to the driver for retention and inspection. (Additionally, the apparatus looks for worn areas of the tyres' surfaces; if the system detects an anomaly which it cannot resolve it will call for or indicate that a visual inspection by a suitable trained operative is required.) The display device 34, which may be a LCD or LED moving message sign or TV screen, is used to indicate to the vehicle driver or the operator the status of the test scanning unit, the remaining time needed to complete the testing and instructions to

proceed forwards, collect printout, etc. The display device 34 can also indicate at which point on the tyre's surface the anomalies have been detected. In the case of a TV screen an actual picture may be displayed to show a bad defect to the customer.

It will be appreciated that the operation of the apparatus of this invention can be initiated via any suitable initiation circuit e.g. a push button, beeping of the horn of the vehicle or flashing of its headlights.

The arrangement shown in Fig 10 of the drawings is similar to that shown in Figs 8 and 9 and shows how the apparatus of this invention might be installed in a garage or petrol filling station, rather in the manner of a car-wash. The wording on the panel 39 is an example of the display that might appear to a motorist, displayed on display 34.

The apparatus illustrated in fig 11 of the drawings is suitable for use by law enforcement personnel, by the side of a road or elsewhere. In this embodiment, the apparatus is small, compact and portable and is arranged to be easily set up and dismantled for temporary use. The apparatus should be capable of being easily assembled with the pairs of ramps arranged in parallel and at a suitable spacing, and with the ramps fixed in position by any suitable means for the duration of use. For example, the ramps may be linked together and/or be of sufficient weight to remain in their proper position during usage. The apparatus is connected, e.g. by means of an RS232 cable or an infra-red link to a portable computer e.g. a notebook or laptop computer, which has facilities for producing hard copy, eg by means of an inkjet or bubblejet printer. The power source for the apparatus of this invention may be the onboard power supply of a vehicle, e.g. a police car, or may be provided by

electrical storage batteries or by an electricity generator. For evidentiary purposes, the printer will normally produce a plurality of identical reports, some for retention by the police and one for the vehicle driver.

The apparatus and method of this invention provide the ability to perform fast, accurate and sophisticated investigations into the condition of a vehicle tyre, and will be greatly welcomed by law enforcement agencies, tyre fitting organizations, tyre manufacturers and by motorists, truck drivers etc.

The invention may be performed otherwise than as has been particularly described; the invention includes within its scope all modifications, alterations, substitutions and improvements that would be apparent to one skilled in the art.

CLAIMS:

1. Apparatus for determining physical characteristics of a tyre mounted on a wheel fitted to a vehicle, which apparatus comprises scanning means adapted to scan a tyre and to produce an output indicative of information relating to tread depth, and indicator means responsive to the output of the scanning means to provide an indication of tread depth.
2. Apparatus according to Claim 1, further comprising means for driving a said tyre in rotation.
3. Apparatus according to Claim 1 or 2, wherein the scanning means comprises a laser sensor.
4. Apparatus according to Claim 1 or 2, wherein the scanning means comprises an ultrasonic sensor.
5. Apparatus according to any of Claims 1 to 4, wherein said indicator means comprises a computer and a display device.
6. Apparatus according to Claim 5, wherein said computer is conditioned to produce a printed record.
7. Apparatus according to Claim 5 or 6, wherein said computer is conditioned to identify the tread pattern of a said tyre.
8. Apparatus according to Claim 7, wherein said computer is conditioned to compare regions of the tread pattern with the identified tread

pattern and to indicate differences found.

9. Apparatus according to Claim 7 or 8, wherein the computer is conditioned to compare the tread pattern of a said tyre with an existing database of tyre tread patterns.

10. Apparatus according to any one of the preceding Claims, wherein the indicator means is adapted in use to provide an indication of whether or not the depth of tread of a said tyre complies with a predetermined criterion.

11. Apparatus according to any one of the preceding Claims, and including pre-payment means for initiating operation of the apparatus.

12. Apparatus for determining physical characteristics of a tyre mounted on a wheel fitted to a vehicle, substantially as hereinbefore described or with reference to the accompanying drawings.

13. A method for determining physical characteristics of a tyre, which method comprises scanning a tyre mounted on a wheel fitted to a vehicle and producing therefrom an output indicative of information relating to tread depth, and providing from said output an indication of tread depth.

14. A method according to Claim 13, which employs a laser sensor to scan the tyre.

15. A method according to Claim 13, which employs an ultrasonic sensor to scan the tyre.

16. A method according to any one of Claims 13 to 15, wherein the tyre is rotated during scanning.
17. A method according to Claim 16, wherein the output from the scanning is processed to identify a tread pattern on the tyre.
18. A method according to Claim 17, wherein regions of the tread are compared with the identified tread pattern and differences therebetween are displayed.
19. A method according to Claim 16 or 17, wherein the tread pattern of the tyre is compared with an existing database of tyre tread patterns.
20. A method of determining physical characteristics of a tyre, substantially as hereinbefore described, or with reference to the accompanying drawings.

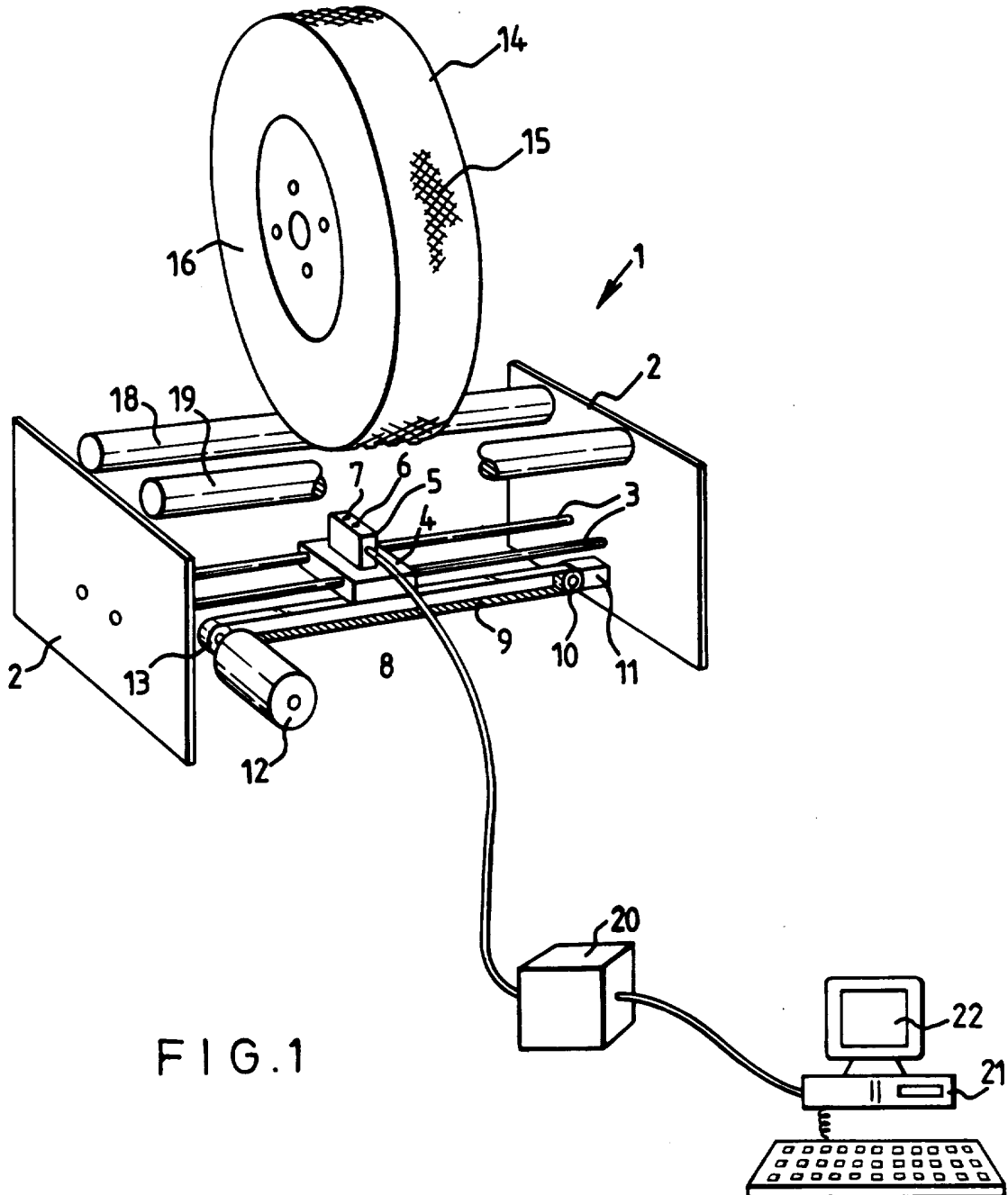

FIG. 1

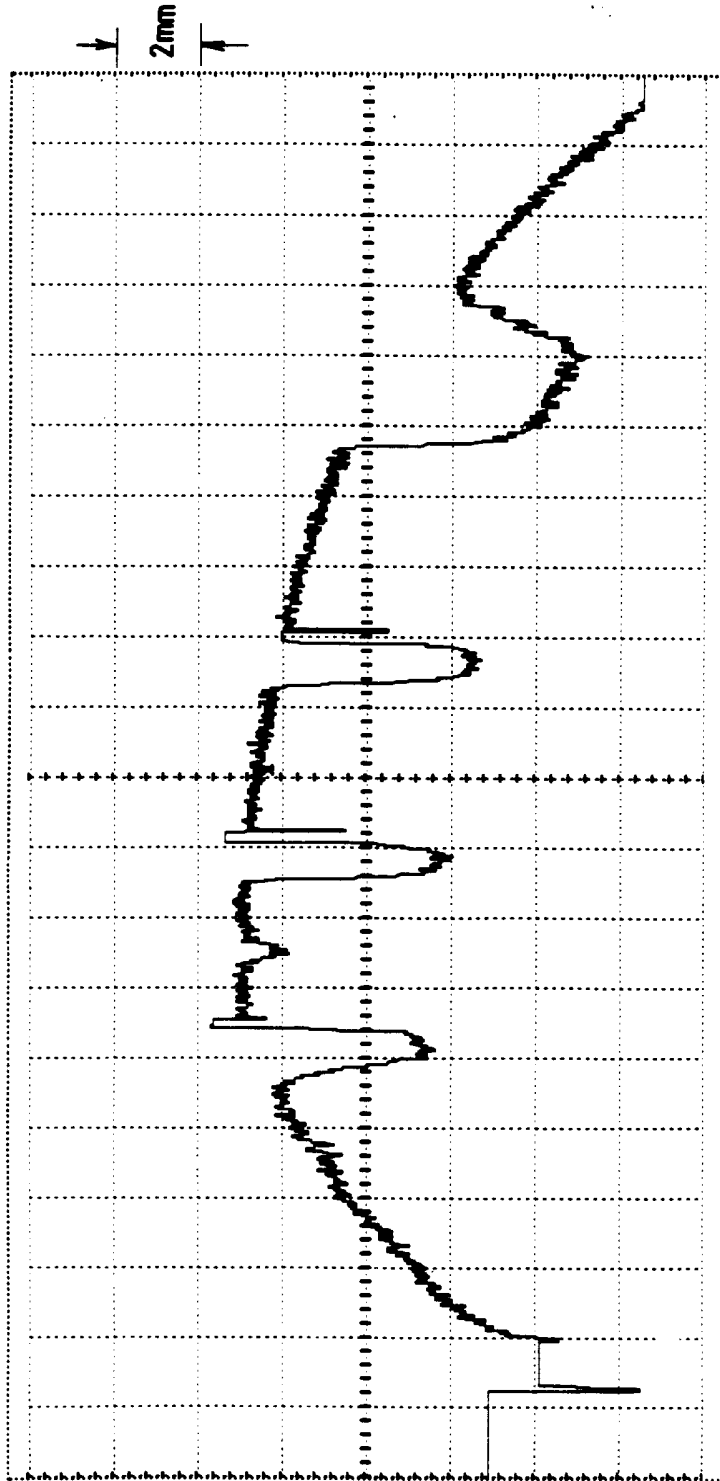

FIG.2

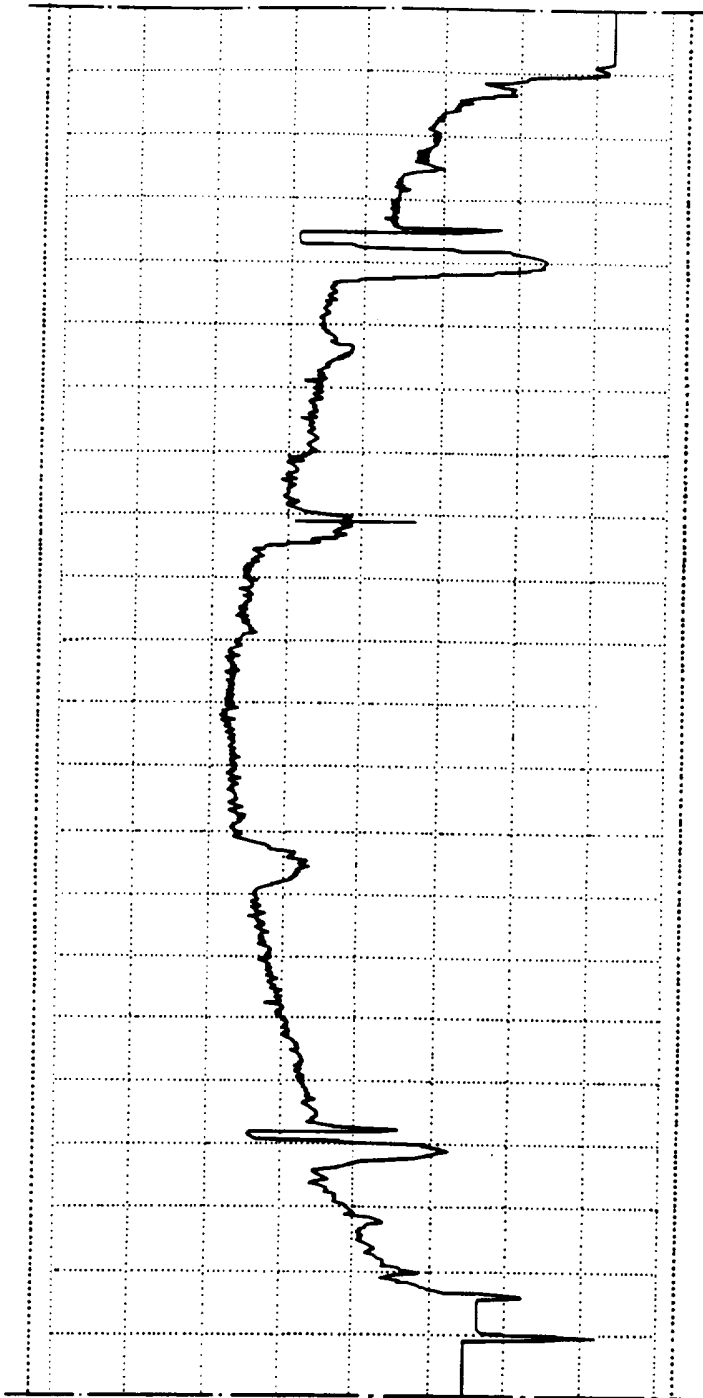

FIG. 3

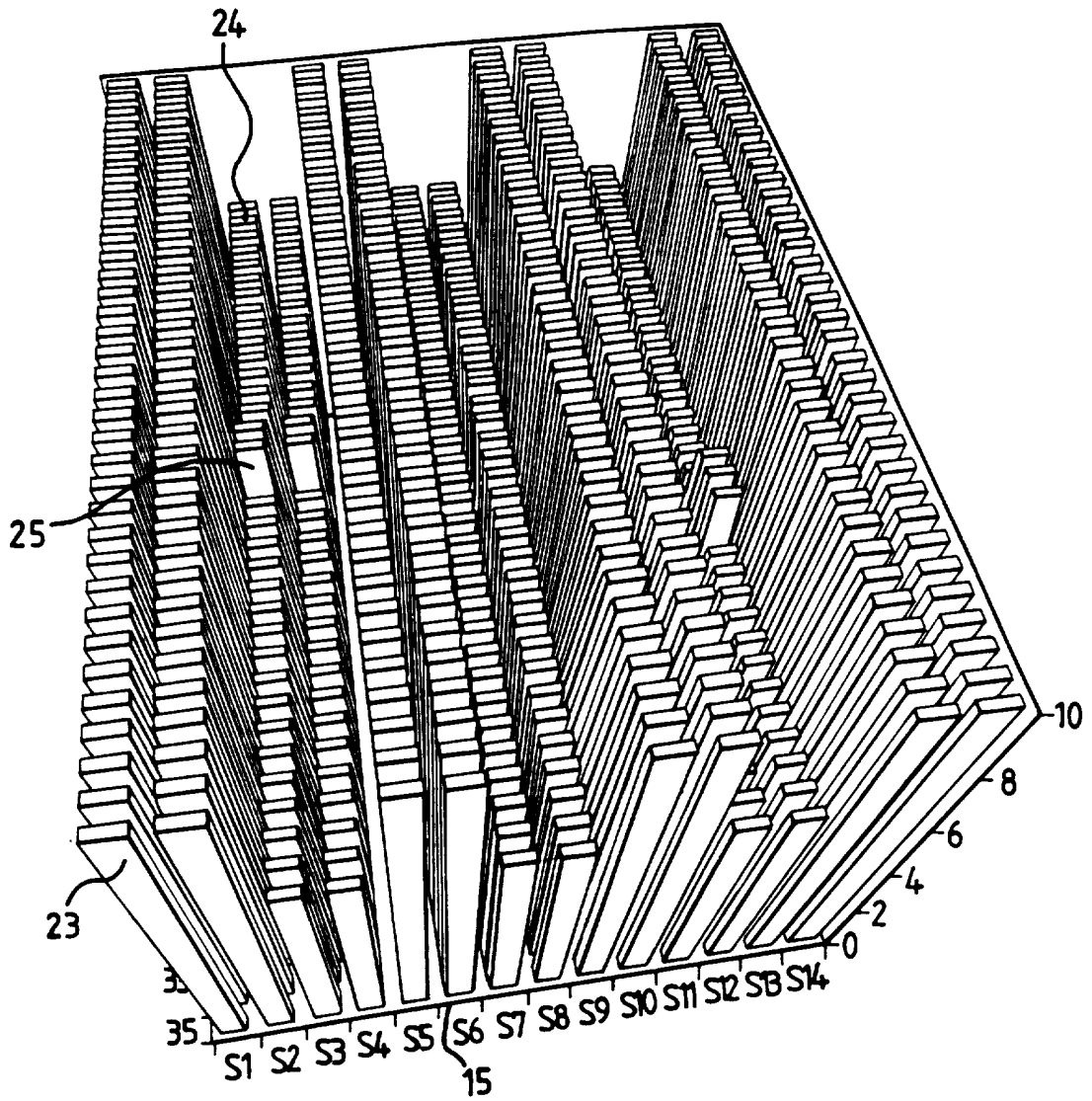

FIG. 4



FIG. 5

6 / 9

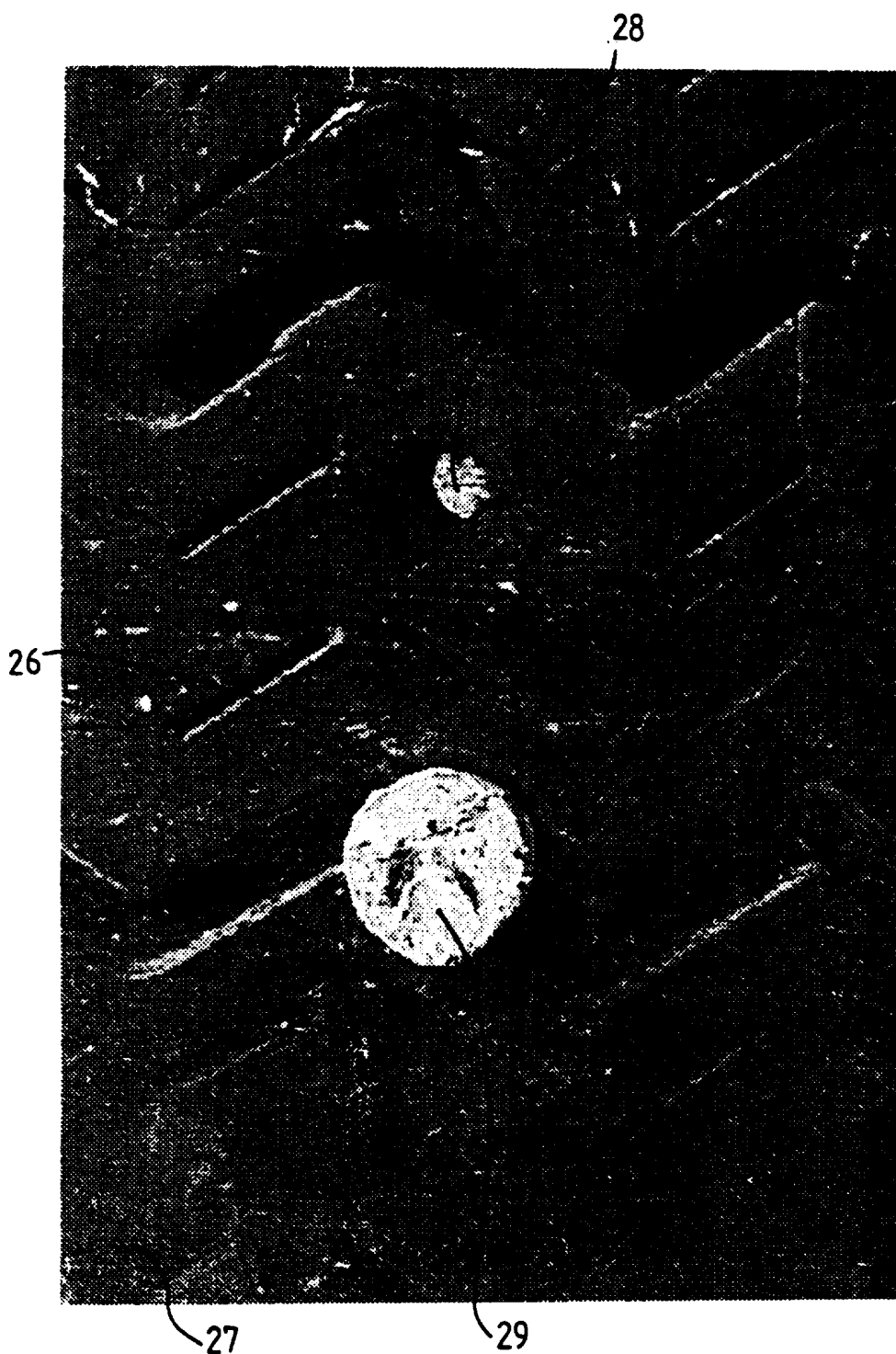
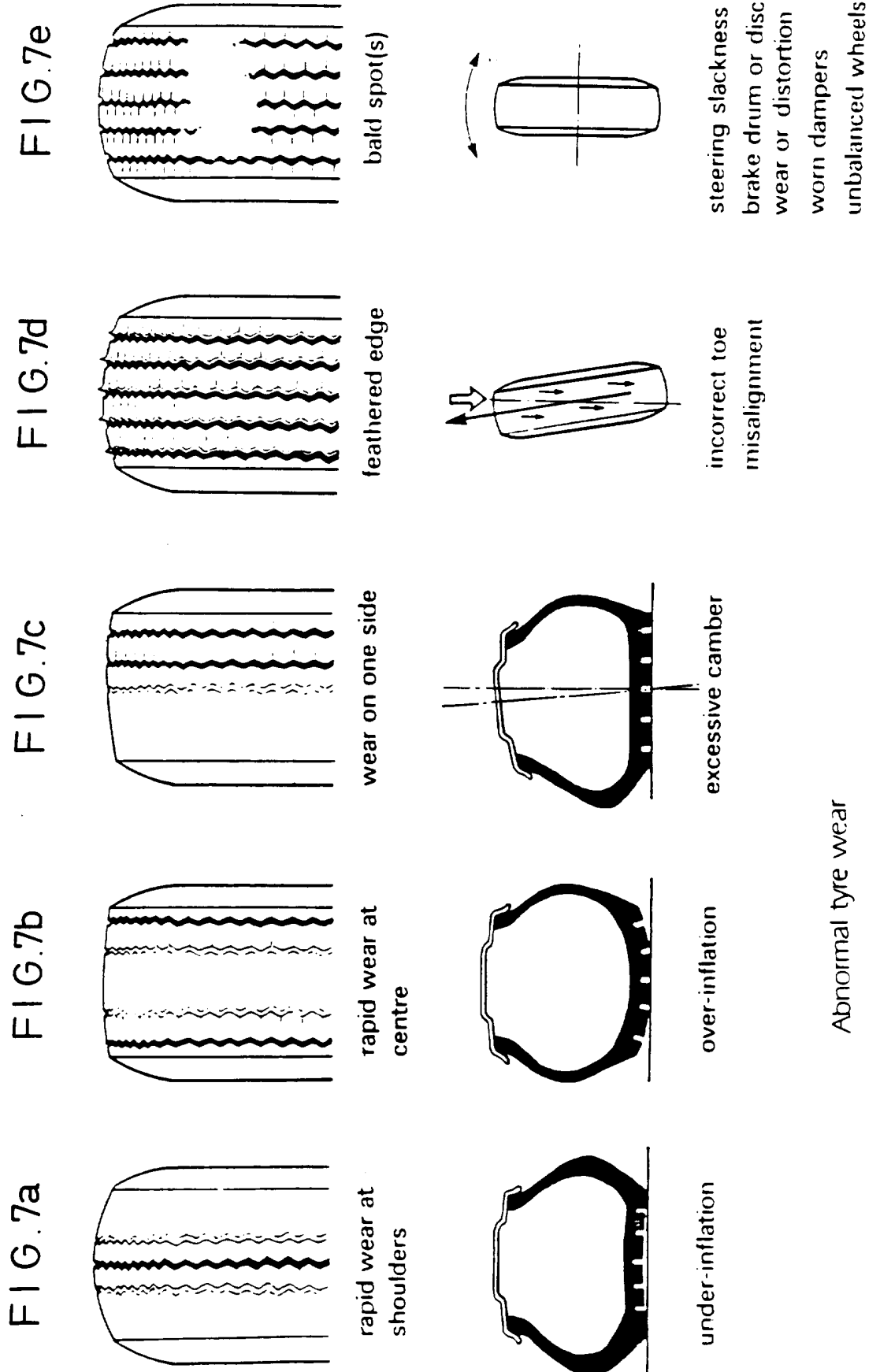

FIG. 6



Abnormal tyre wear

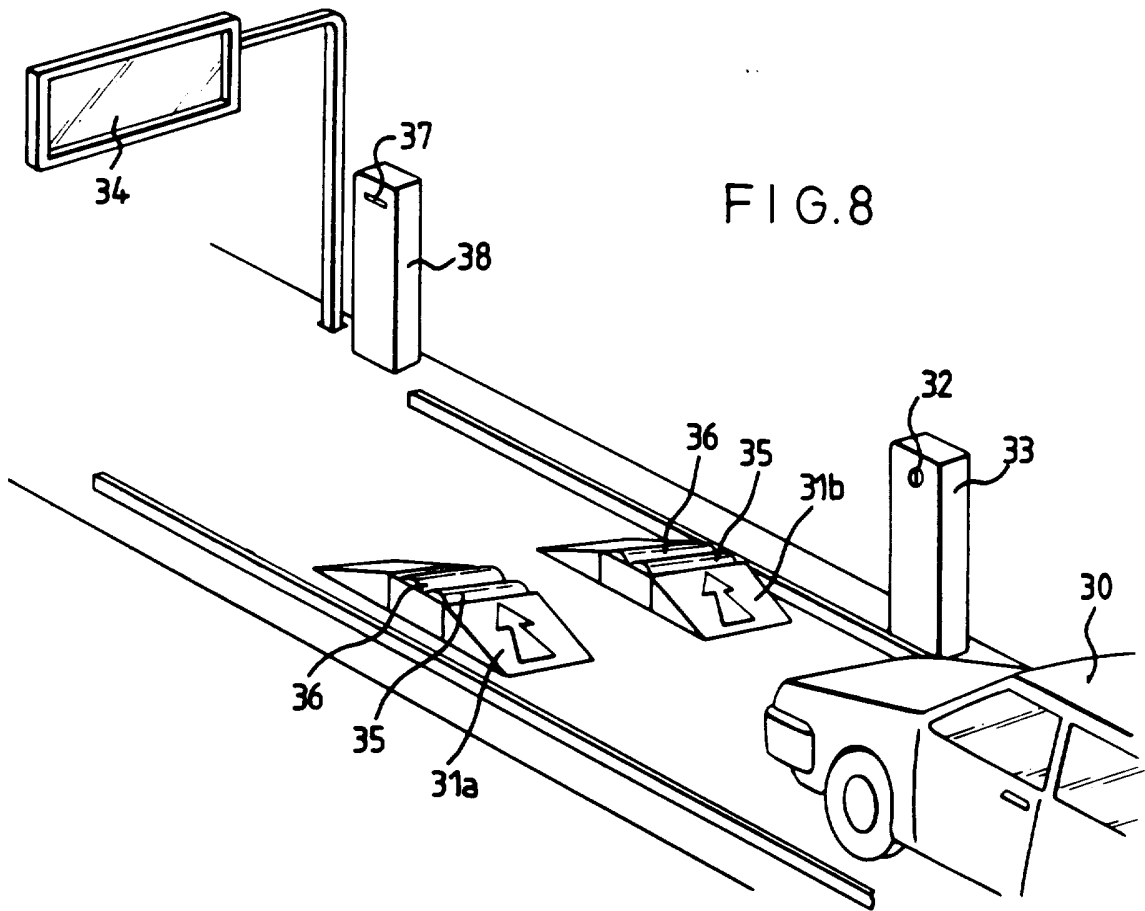

FIG. 8

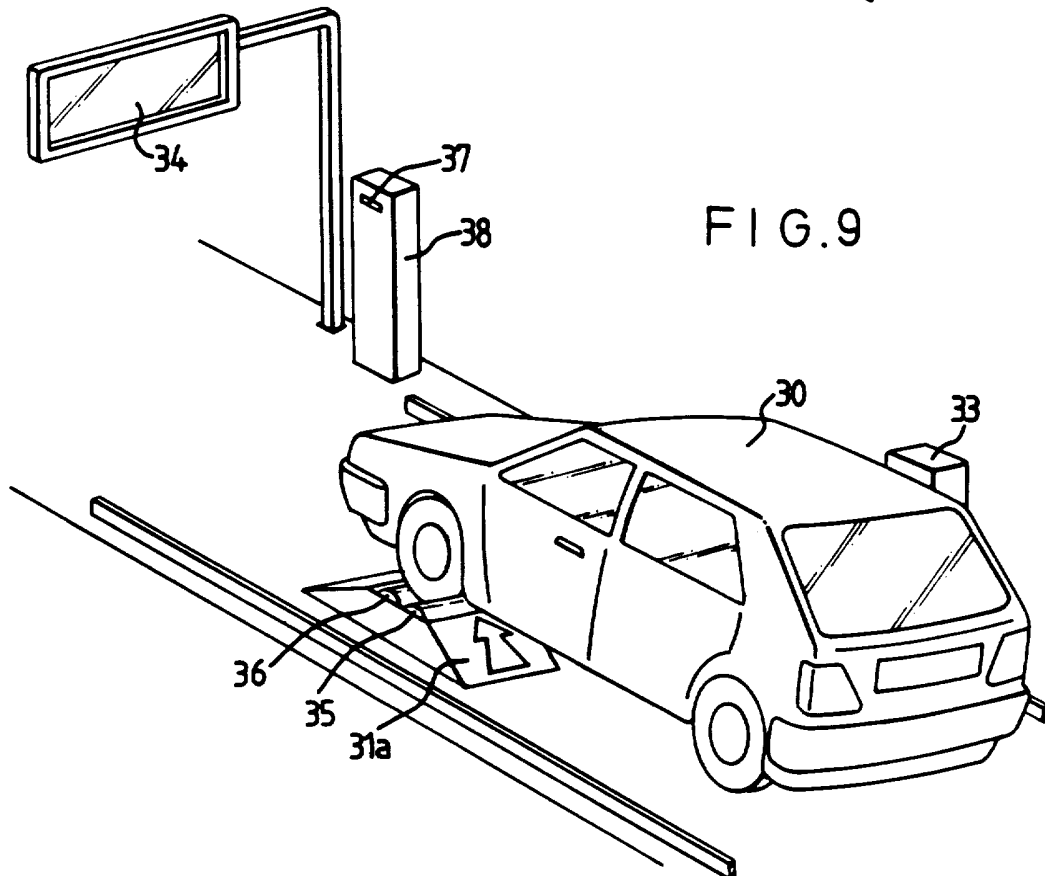

FIG. 9

FIG. 10

ANALYSIS
COMPLETE
PLEASE DRIVE
REAR WHEELS
ONTO ROLLERS

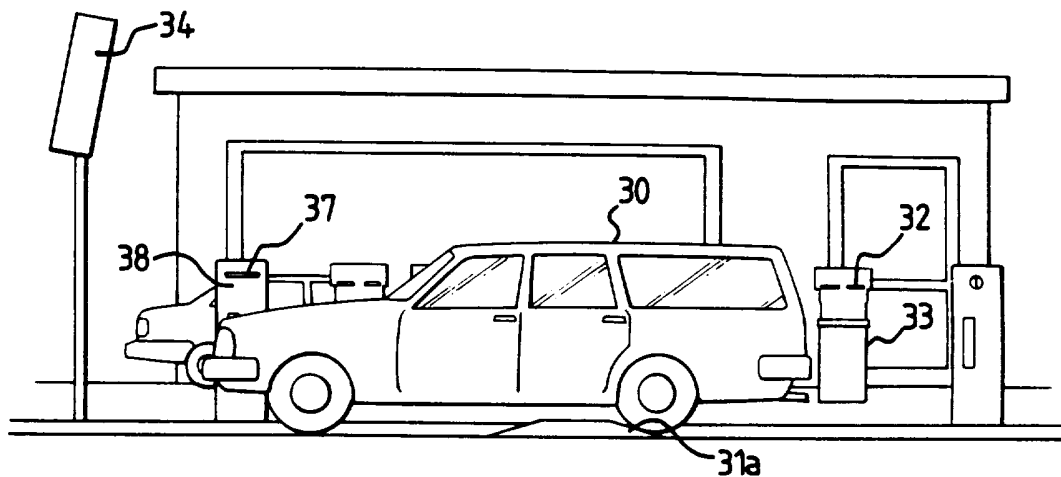
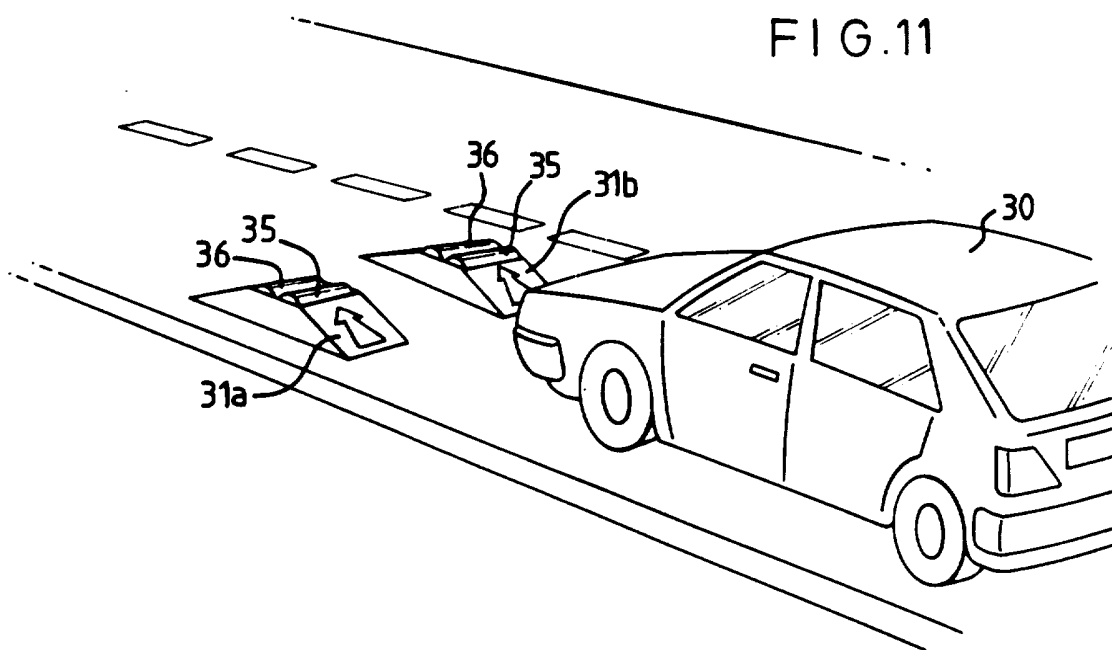

FIG. 11



INTERNATIONAL SEARCH REPORT

International Application No
PCT/GB 95/02340

A. CLASSIFICATION OF SUBJECT MATTER
IPC 6 G01B11/22 G01B21/18

According to International Patent Classification (IPC) or to both national classification and IPC

B. FIELDS SEARCHED

Minimum documentation searched (classification system followed by classification symbols)
IPC 6 G01B G01M

Documentation searched other than minimum documentation to the extent that such documents are included in the fields searched

Electronic data base consulted during the international search (name of data base and, where practical, search terms used)

C. DOCUMENTS CONSIDERED TO BE RELEVANT

| Category * | Citation of document, with indication, where appropriate, of the relevant passages | Relevant to claim No. |
|------------|---|--|
| X A | DE,A,43 16 984 (MERCEDES-BENZ AG) 18 August 1994 see introduction; see column 2, line 27 - column 5, line 22; figures 1-5 --- | 1,3-6, 12-15, 17,20 2,7-11, 16,18,19 |
| X | DE,A,41 26 754 (THE YOKOHAMA RUBBER CO., LTD.) 27 February 1992 see column 2, line 35 - column 3, line 64; figures 2,3 see column 4, line 24 - column 6, line 3; claim 3; figures 1-3 ----- | 1-3, 5-10, 12-20 |

Further documents are listed in the continuation of box C.

Patent family members are listed in annex.

* Special categories of cited documents :

- *A* document defining the general state of the art which is not considered to be of particular relevance
- *E* earlier document but published on or after the international filing date
- *L* document which may throw doubts on priority claim(s) or which is cited to establish the publication date of another citation or other special reason (as specified)
- *O* document referring to an oral disclosure, use, exhibition or other means
- *P* document published prior to the international filing date but later than the priority date claimed

- *T* later document published after the international filing date or priority date and not in conflict with the application but cited to understand the principle or theory underlying the invention
- *X* document of particular relevance; the claimed invention cannot be considered novel or cannot be considered to involve an inventive step when the document is taken alone
- *Y* document of particular relevance; the claimed invention cannot be considered to involve an inventive step when the document is combined with one or more other such documents, such combination being obvious to a person skilled in the art.
- *&* document member of the same patent family

Date of the actual completion of the international search

8 January 1996

Date of mailing of the international search report

- 5.02.96

Name and mailing address of the ISA
European Patent Office, P.B. 5818 Patentlaan 2
NL - 2280 HV Rijswijk
Tel. (+ 31-70) 340-2040, Tx. 31 651 epo nl,
Fax: (+ 31-70) 340-3016

Authorized officer

Visser, F

INTERNATIONAL SEARCH REPORT

Information on patent family members

| |
|--|
| International Application No PCT/GB 95/02340 |
|--|

| Patent document cited in search report | Publication date | Patent family member(s) | Publication date |
|--|------------------|-------------------------|------------------|
| DE-A-4316984 | 18-08-94 | NONE | |
| | | | |
| DE-A-4126754 | 27-02-92 | JP-A- 4104034 | 06-04-92 |
| | | US-A- 5174151 | 29-12-92 |
| | | | |