

(No Model.)

4 Sheets—Sheet 1.

G. G. WOLFE.

GRATE AND FIRE CHAMBER FOR STOVES OR RANGES.

No. 525,831. χ^1

Patented Sept. 11, 1894.

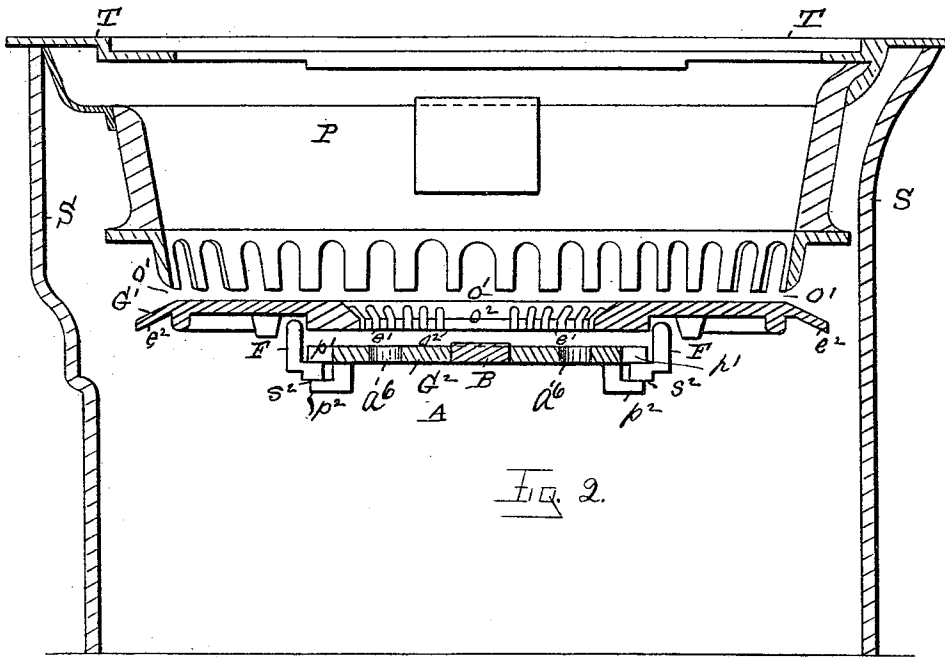
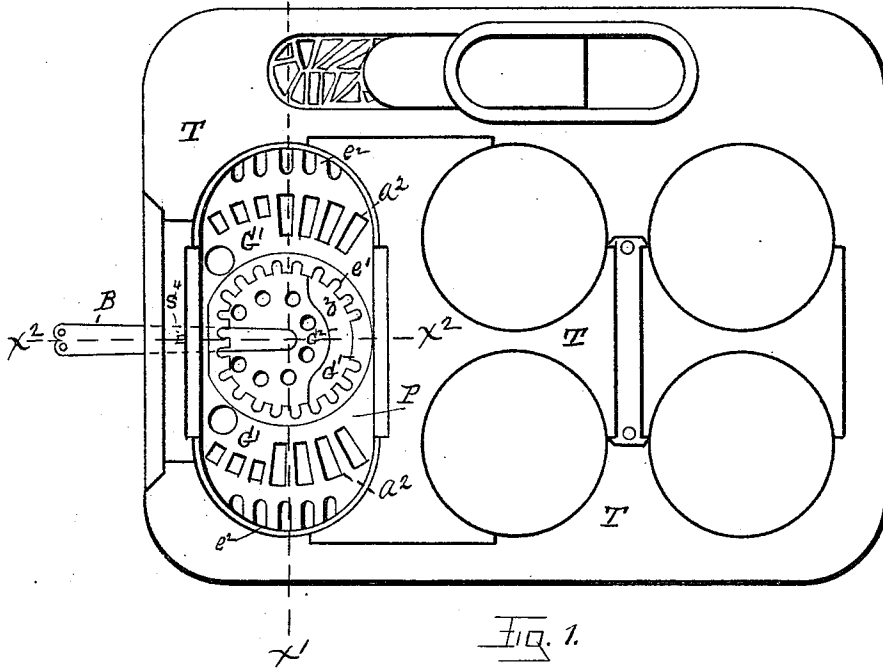

WITNESSES

Oscar A. Michel.
 Charles S. Brintnal

INVENTOR

Gordon S. Wolfe
 By W. E. Hagan atty

G. G. WOLFE.

GRATE AND FIRE CHAMBER FOR STOVES OR RANGES.

No. 525,831.

Patented Sept. 11, 1894.

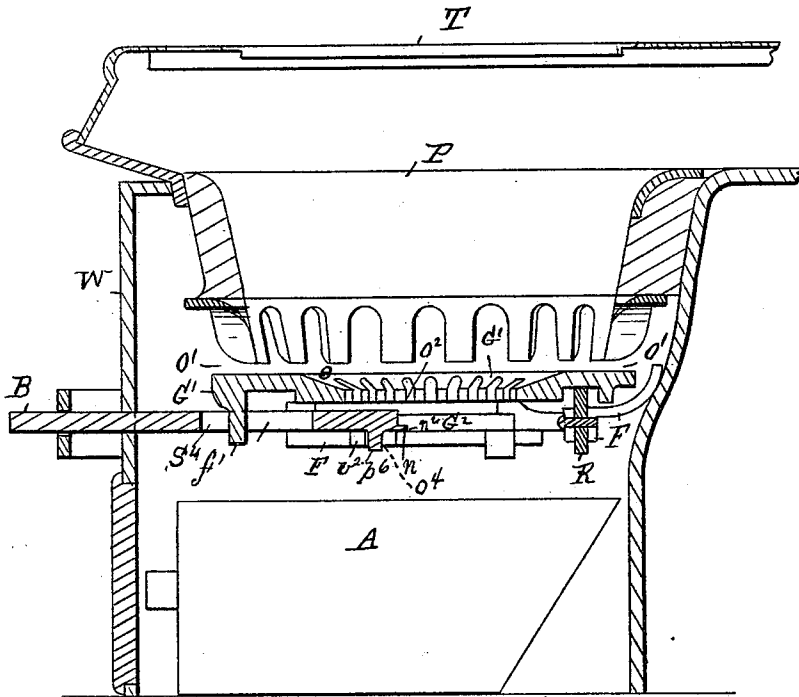

Fig. 3.

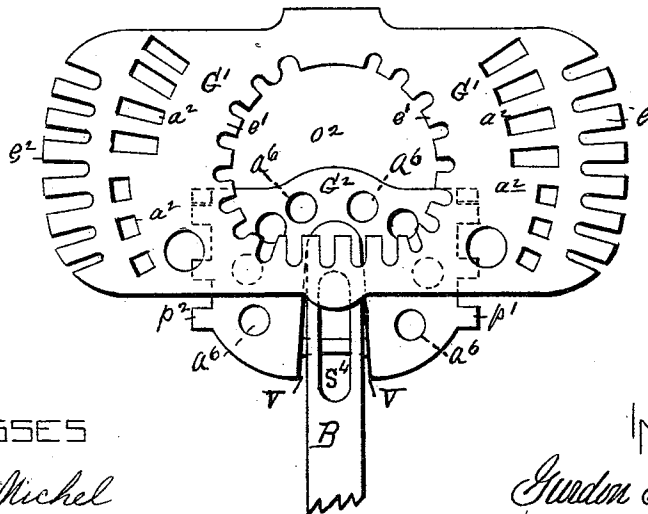

Fig. 6.

WITNESSES

Oscar A. Michel

Charles S. Brintnall

INVENTOR

Gordon S. Wolfe

By W. C. Fagan atty

(No Model.)

4 Sheets—Sheet 3.

G. G. WOLFE.

GRATE AND FIRE CHAMBER FOR STOVES OR RANGES.

No. 525,831.

Patented Sept. 11, 1894.

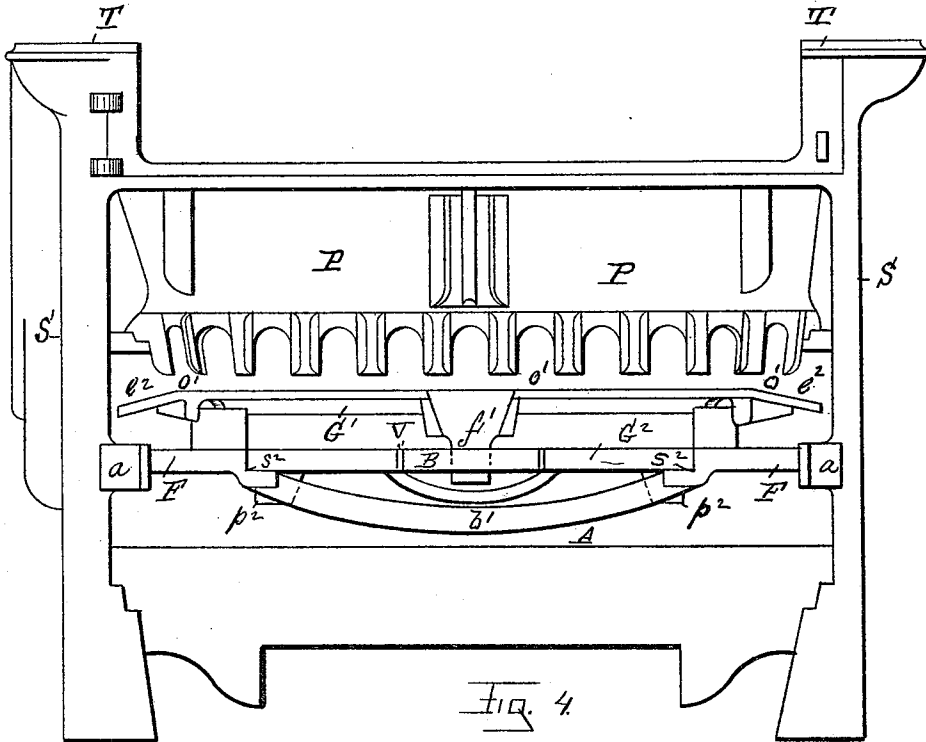

Fig. 4

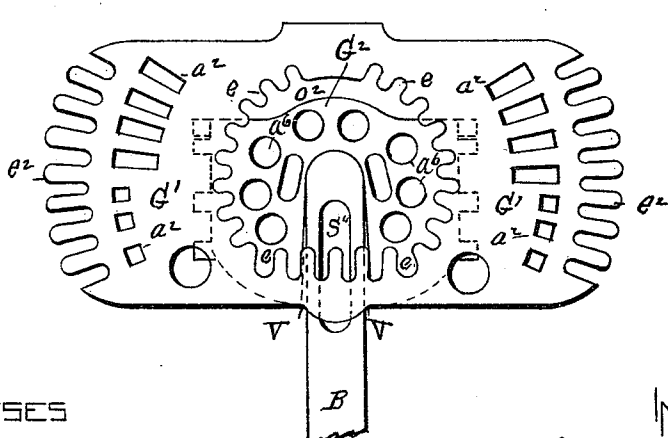

Fig. 5

WITNESSES
 Oscar A. Michel
 Charles S. Brintnall

INVENTOR
 Gordon S. Wolfe
 by W. E. Hagan atty

G. G. WOLFE.

GRATE AND FIRE CHAMBER FOR STOVES OR RANGES.

No. 525,831.

Patented Sept. 11, 1894.

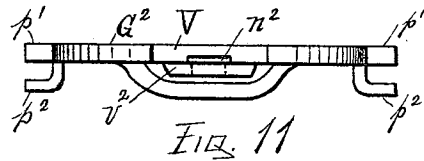
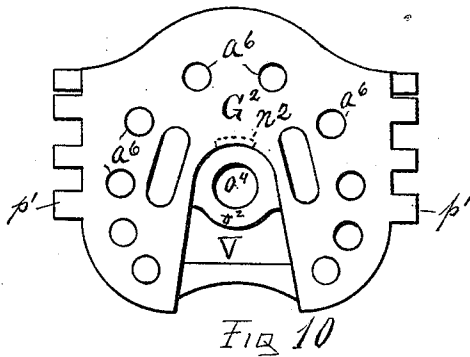
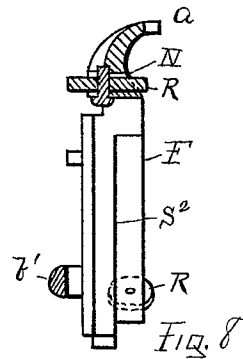
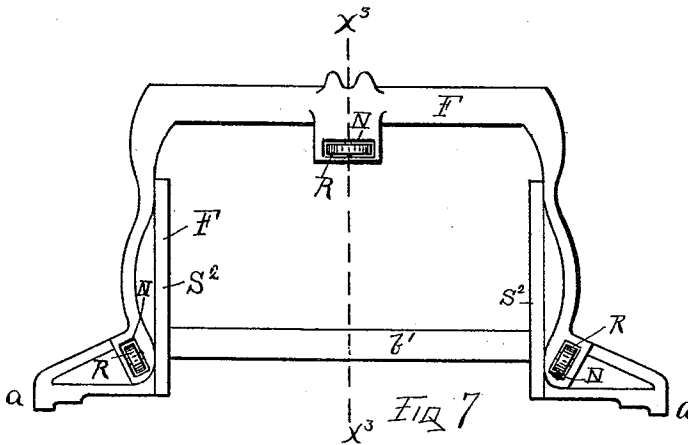
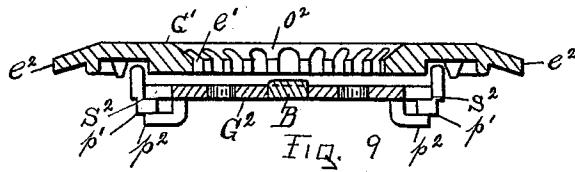

WITNESSES
 Geo. A. Darby.
 Alexander S. Brintnall

INVENTOR
 Gordon G. Wolfe by
 W. C. Hagan his atty

UNITED STATES PATENT OFFICE.

GURDON G. WOLFE, OF TROY, NEW YORK, ASSIGNOR TO THE FULLER & WARREN COMPANY, OF SAME PLACE.

GRATE AND FIRE-CHAMBER FOR STOVES OR RANGES.

SPECIFICATION forming part of Letters Patent No. 525,831, dated September 11, 1894.

Application filed March 25, 1889. Serial No. 304,598. (No model.)

To all whom it may concern:

Be it known that I, GURDON G. WOLFE, of the city of Troy, county of Rensselaer, and State of New York, have invented a new and useful Improvement in Grates and Fire-Chambers for Stoves or Ranges, of which the following is a specification.

My invention relates to the manner of constructing and arranging an oval grate to adapt it to be horizontally and reciprocatingly rotated on its diametrical center, for use in combination with an oval fire-chamber. Where a square fire-box or chamber is used having greater length than width, the combustion of the fuel is not uniform therein from the fact that the draft force will seek its most easy means and direct passage through the grate and fire at the front edge of the latter, while at the corners and rear sides of the chamber the combustion is less vigorous and effective; and when such a fire-pot or chamber is provided with a grate that is shaken by a lateral and horizontal vibration from end to end, each reciprocation of the grate where stopping suddenly at the end with a jar, has the effect to pile up the coal at the ends of the chamber, where the best combustion of the fuel is not had. It is to remedy these difficulties that is the object of my invention.

Accompanying this specification to form a part of it there are four plates of drawings, containing eleven figures illustrating my invention, with the same designation of parts by letter reference used in all of them.

Of these illustrations Figure 1 shows a top view of a cooking range containing my invention and improvement. Fig. 2 shows a section taken on the line x', x' , of Fig. 1, through the fire-chamber and grate. Fig. 3 is a section taken through the grate and fire-pot on the line x^2, x^2 , of Fig. 1; the parts illustrated at Figs. 2 and 3 being shown in larger size than at Fig. 1. Fig. 4 illustrates a front elevation of a range, containing my invention with a part of the front wall of the stove removed, where opposite the fire-chamber and grate. Fig. 5 shows a top view of the grate removed from the stove. Fig. 6 shows another top view of the grate with the draw center shown as drawn out. Fig. 7 is a top

view of the frame which supports the grate and which frame contains rollers on which the grate turns. Fig. 8 is a section of the grate frame taken on the line x^3, x^3 , of Fig. 7. Fig. 9 shows a longitudinal and central section of the grate removed from the stove, and reduced in size for convenience of illustration. Fig. 10 shows a top view of the supplemental or draw center part of the grate shown as separated from the latter. Fig. 11 is a front edge elevation of the draw center part of the grate shown at Fig. 10.

The several parts of the range thus illustrated, and also of the parts thereof containing my invention are designated by letter reference and the function of the parts is described as follows:

The letter T designates the boiler hole top of the range; S, its side walls; A, its ash-pit, and W its front.

The letter P designates the fire-chamber, which is of an elliptical or oval form having its interior side walls tapering inwardly as extended downwardly.

The letter G¹, designates the grate proper, which is also elliptical in form, and it is supported within the range on the frame F, far enough below the bottom of the fire-chamber P to leave the usual clinker cleaning passage O'. The grate proper is made with air passages a^2 , and is constructed with a downwardly projected foot f' at the front, the function of which will be subsequently described. This grate proper rests on the rollers R of the frame F, and has downcast serrated ends e^2 , and a downcast serrated rim e' , surrounding the central opening o^2 . This frame F is attached to the inner walls of the stove by connections made at a , and it is constructed with a cross web or brace b' , slide-ways S², and rollers R turning in slots N, with the face of the rollers projecting above the face of the frame F.

The letter G², designates the draw center part of the grate, formed with projections p' , on its side edges, and an outward projection p^2 , on its under opposite side edges. The projection p' , being arranged to rest loosely in the slide ways S² of the frame F, and the outward turned projections p^2 , to pass in under the lower edge of the slide ways at each side to

keep the parts in place as the draw center is moved out or pushed in. This draw center grate part is provided with apertures a^6 .

The letter V designates a U-form opening 5 made in the draw center part of the grate at the front, which opening widens out as extended frontwardly, and at its inner end near the center of the grate part G^2 it is constructed with a shelf v^2 , made with an opening o^4 , for 10 the entrance of a pivot pin p^6 , on the lower side of the shaking bar B, said bar where beyond the pivot pin being constructed on its inner end with a point n , that enters a slot n^2 , see Figs. 3, 10, and 11, in the grate part G^2 , at 15 the end of said opening V, so as to vibrate therein.

The shaking bar B is made with a longitudinal slot S^4 , adapted to receive the downwardly projected foot f' , of the grate proper, 20 see Fig. 3, so that when the bar B is in position and is reciprocated laterally on its pivot pin p^6 , between the outwardly flaring sides of the opening V, the grate proper is reciprocatingly rotated by the engagement of the foot 25 f' , with the slot in the bar. When it is desired to dump the fire, then the bar B is drawn out and with it the draw center part G^2 , which leaves an opening through which the contents of the fire chamber may be passed to the ash- 30 pit. The supplemental or draw center grate part G^2 is arranged enough below the grate proper G' to allow air to freely enter between them to aid the combustion; and the general effect upon the fuel on the grate when the latter 35 is reciprocatingly rotated is to keep the fuel in an even layer upon the grate.

I am well aware that a drawer center grate

constructed with slide-ways below a grate proper is a well known feature of stove structure, and I disclaim the same broadly considered. 40

Having thus described my invention, what I claim, and desire to secure by Letters Patent, is—

1. The combination with the fire-pot P and 45 the supporting frame F, of the elliptically formed grate G' formed with downcast serrated ends e^2 , a central opening and a foot f' , the draw-center grate G^2 mounted to slide on the frame F below the grate G' and formed 50 with a U-shaped opening V terminating in a slot n^2 , and the shaking-bar B formed with a slot to engage the foot f' of the grate G' and a point n to engage the slot n^2 of the grate G^2 , substantially as and for the purpose specified. 55

2. The combination of the grate G' formed with downcast serrated ends and serrated central portion provided with an opening O^2 , and formed with the foot f' ; the frame F having 60 rollers R journaled therein and slide-ways S^2 ; the draw-center grate G^2 mounted on the slides of the frame F and formed with a flaring opening V having a shelf v^2 , having an opening o^4 , and the shaking-bar B formed with a slot to take the foot f' , and a pin p^6 to 65 engage in the opening o^4 , substantially as described.

Signed at Troy, New York, this 2d day of August, 1888, and in the presence of the two witnesses whose names are hereto written.

GURDON G. WOLFE.

Witnesses:

W. E. HAGAN,
CHARLES S. BRINTNALL.