

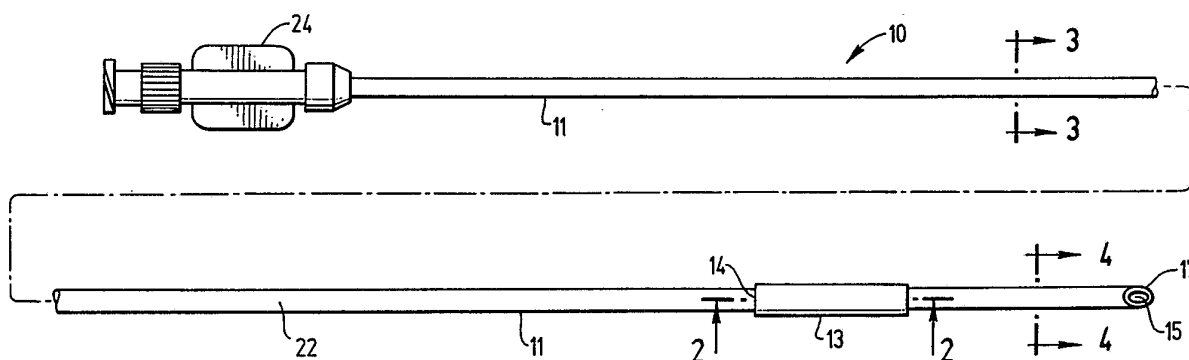

INTERNATIONAL APPLICATION PUBLISHED UNDER THE PATENT COOPERATION TREATY (PCT)

<p>(51) International Patent Classification ⁵ : A61M 29/02</p>	<p>A1</p>	<p>(11) International Publication Number: WO 93/13827 (43) International Publication Date: 22 July 1993 (22.07.93)</p>
<p>(21) International Application Number: PCT/US93/00067 (22) International Filing Date: 8 January 1993 (08.01.93) (30) Priority data: 07/818,288 9 January 1992 (09.01.92) US (71) Applicant: ADVANCED CARDIOVASCULAR SYSTEMS, INC. [US/US]; 3200 Lakeside Drive, Box 58167, Santa Clara, CA 95052-8167 (US). (72) Inventor: SIRHAN, Motasim, M. ; 3707 Poinciana Drive, Apt. #43, Santa Clara, CA 95051 (US). (74) Agents: LYNCH, Edward, J. et al.; Crosby, Heafey, Roach & May, 700 South Flower Street, Suite 2200, Los Angeles, CA 90017 (US).</p>		<p>(81) Designated States: CA, JP, European patent (AT, BE, CH, DE, DK, ES, FR, GB, GR, IE, IT, LU, MC, NL, PT, SE). Published <i>With international search report.</i></p>

(54) Title: GUIDEWIRE REPLACEMENT DEVICE



(57) Abstract

A guidewire replacement device (10) having an elongated catheter shaft with an inner lumen (15) extending within the catheter shaft, a proximal guidewire port (14) spaced at least 1 cm from the distal end of the catheter which is in fluid communication with the inner lumen and distal guidewire port in the distal end of the catheter which is also in fluid communication with the inner lumen. The proximal end of an in-place guidewire (28) is inserted through the distal guidewire port (14) and advanced through the inner lumen until the proximal end of the guidewire extends through the proximal guidewire port. The exchange device is advanced over the guidewire. With the distal end of the exchange device well seated within the proximal guidewire port of the dilatation catheter (27), the in-place guidewire can be withdrawn from the patient. A replacement guidewire (21) is advanced through the inner lumen of the exchange device.

FOR THE PURPOSES OF INFORMATION ONLY

Codes used to identify States party to the PCT on the front pages of pamphlets publishing international applications under the PCT.

AT	Austria	FR	France	MR	Mauritania
AU	Australia	GA	Gabon	MW	Malawi
BB	Barbados	GB	United Kingdom	NL	Netherlands
BE	Belgium	GN	Guinea	NO	Norway
BF	Burkina Faso	GR	Greece	NZ	New Zealand
BG	Bulgaria	HU	Hungary	PL	Poland
BJ	Benin	IE	Ireland	PT	Portugal
BR	Brazil	IT	Italy	RO	Romania
CA	Canada	JP	Japan	RU	Russian Federation
CF	Central African Republic	KP	Democratic People's Republic of Korea	SD	Sudan
CG	Congo	KR	Republic of Korea	SE	Sweden
CH	Switzerland	KZ	Kazakhstan	SK	Slovak Republic
CI	Côte d'Ivoire	LJ	Liechtenstein	SN	Senegal
CM	Cameroon	LK	Sri Lanka	SU	Soviet Union
CS	Czechoslovakia	LU	Luxembourg	TD	Chad
CZ	Czech Republic	MC	Monaco	TG	Togo
DE	Germany	MG	Madagascar	UA	Ukraine
DK	Denmark	ML	Mali	US	United States of America
ES	Spain	MN	Mongolia	VN	Viet Nam
FI	Finland				

- 1 -

GUIDEWIRE REPLACEMENT DEVICE**BACKGROUND OF THE INVENTION**

This invention generally relates to intravascular procedures, such as percutaneous transluminal coronary angioplasty (PTCA), and particularly to the exchange of guidewires during such procedures.

5 In classic PTCA procedures, a guiding catheter having a preshaped distal tip is percutaneously introduced into the cardiovascular system of a patient and advanced therein until the preshaped distal tip thereof is disposed within the aorta adjacent the ostium of the desired coronary artery. The guiding catheter is twisted or torqued from its proximal end, which extends outside of the patient, to turn the distal tip of the guiding
10 catheter so that it can be guided into the coronary ostium and seated therein. A dilatation catheter having a dilatation balloon on the distal end thereof and a guidewire slidably disposed within an inner lumen of the dilatation catheter are introduced into and advanced through the proximal end of the guiding catheter to the distal tip of the guiding catheter seated within the coronary ostium. The distal tip of the guidewire is usually manually
15 shaped (curved) by the physician or one of the attendants before it is introduced into the guiding catheter along with the dilatation catheter.

The shaped distal tip of the guidewire is first advanced out the distal tip of the guiding catheter into the patient's coronary artery. A torque is applied to the proximal
20 end of the guidewire, which extends out of the proximal end of the guiding catheter as it is advanced within the coronary anatomy, to guide the curved or otherwise shaped distal

SUBSTITUTE SHEET

end of the guidewire into a branch artery targeted for dilatation. The advancement of the guidewire within the target artery continues until it crosses the lesion to be dilated.

5 The dilatation catheter is then advanced out of the distal tip of the guiding catheter, over the previously advanced guidewire, until the balloon on the distal extremity of the dilatation catheter is properly positioned across the lesion to be dilated. Once properly positioned across the lesion, the flexible, relatively inelastic dilatation balloon on the catheter is inflated to a predetermined size with radiopaque liquid at relatively high pressures (*e.g.*, generally 4-12 atmospheres) to dilate the stenosed region of the diseased
10 artery. One or more inflations of the balloon may be required to complete the dilatation of the stenosis. After the last dilatation, the balloon is deflated so that the dilatation catheter can be removed from the dilated stenosis and so that blood flow can resume through the dilated artery.

15 Further details of guiding catheters, dilatation catheters, guidewires, and the like for angioplasty procedures can be found in U.S. Patent 4,323,071 (Simpson-Robert); U.S. Patent 4,439,185 (Lundquist); U.S. Patent 4,468,224 (Enzmann *et al.*); U.S. Patent 4,516,972 (Samson); U.S. Patent 4,438,622 (Samson *et al.*); U.S. Patent 4,554,929 (Samson *et al.*); U.S. Patent 4,582,185 (Samson); U.S. Patent 4,616,652 (Simpson); U.S.
20 Patent 4,638,805 (Powell); U.S. Patent 4,748,986 (Morrison *et al.*); U.S. Patent 4,898,577 (Badger *et al.*); U.S. Patent 4,748,982 (Horzewski *et al.*); and U.S. Patent 4,821,722 (Miller *et al.*) which are hereby incorporated herein in their entirety by reference thereto.

The assignee of the present invention, Advanced Cardiovascular Systems, Inc., markets an improved dilatation catheter under the trademark ACS RX[®] coronary diliation catheter which is described and claimed in U.S. Patent 5,040,548 (Yock), U.S. Patent 5,061,273 (Yock) and U.S. Patent 4,748,982 (Horzewski *et al.*). This dilatation catheter has a short guidewire receiving sleeve or inner lumen extending through the distal portion of the catheter. The sleeve extends proximally a distance of at least 10 cm and usually not more than about 50 cm from a first guidewire port in the distal end of the catheter to a second guidewire port in the catheter spaced proximally from the inflatable balloon of the catheter. A slit is preferably provided in the catheter wall which extends distally from the second guidewire port, preferably to a location proximal to the proximal end of the inflatable balloon to aid in the removal of the catheter from a guidewire. The structure of the catheter allows for the rapid exchange of the catheter without the need for the use of an exchange wire or adding a guidewire extension to the proximal end of the guidewire. The design of this catheter has been widely praised by the medical profession and has met with much commercial success in the market place because of its unique design.

A substantial improvement in the rapid exchange type dilatation catheters, such as described above, has recently been made by McInnes *et al.* which is described in copending applications Serial No. 07/476,056, filed February 7, 1990 and Serial No. 07/541,264 filed June 19, 1990, both entitled READILY EXCHANGEABLE PERFUSION DILATATION CATHETER, which are incorporated herein by reference. In these readily exchangeable dilatation catheters, perfusion ports are provided in the catheter shaft proximal and distal to the balloon which are in fluid communication with the guidewire

receiving inner lumen to allow blood to perfuse distal to the catheter when the balloon was inflated.

5 However, one inconvenience with the above described dilatation catheter systems adapted for rapid exchangeability has been the inability to remove a guidewire already in place within a patient's vasculature without losing access to the vascular location. There has been no convenient way in which a replacement guidewire might be advanced through the vasculature and into the short guidewire receiving inner lumen in the distal extremity of the dilatation catheter. The in-place guidewire may need to be replaced
10 with another guidewire having a different structure, e.g. from a floppy-type design with a separate shaping ribbon to an intermediate or standard with a core wire which extends to the distal tip of the guidewire, or it may need to be withdrawn in order to reshape the distal tip and then be reinserted. In both instances the guidewire is referred to herein as the replacement guidewire.

15

What has been needed and heretofore unavailable is a intraluminal catheter system which provides for the easy and rapid exchange of both the catheter or the guidewire used to guide the catheter through a body lumen or both. The present invention satisfies these and other needs.

20

SUMMARY OF THE INVENTION

This invention is directed to a intraluminal catheter system which provides for the exchange of the guidewire and to the use of this system, particularly within the

coronary arteries of a human patient during an angioplasty procedure.

The guidewire exchange device of the invention generally comprises an elongated catheter shaft with a guidewire receiving inner lumen extending therein to a
5 guidewire port in the distal end of the catheter. A proximal guidewire port is provided in the catheter shaft spaced longitudinally at least 1 cm or more from the distal end of the shaft which is in fluid communication with the guidewire receiving inner lumen. The catheter shaft includes a relatively long proximal tubular section and a relatively short distal tubular section. The proximal guidewire port is located at or near the transition
10 between the proximal and distal tubular sections of the exchange device. The distal tubular section is preferably adapted to guide the proximal end of a guidewire out the proximal guidewire port as the proximal end of the guidewire is advanced through the inner lumen of the guidewire exchange device from the distal guidewire port. In one preferred
15 embodiment, the transition between the proximal and distal sections are slightly angled, e.g. about 5 to about 40 degrees, preferably about 5 to about 30 degrees, so that the proximal end of the guidewire will advance out the proximal guidewire port. The distal end of the distal tubular section of the guidewire exchange device is shaped, e.g. tapered, and dimensioned so as to be easily inserted into the proximal guidewire port of a readily
20 exchangeable catheter as the exchange device is advanced over a guidewire which extends out the proximal guidewire port of the readily exchangeable catheter.

The guidewire exchange device is adapted to be advanced over a guidewire, which is disposed within a patient, either until the distal tip of the exchange device is seated within the proximal guidewire port of the readily exchangeable catheter or the distal

end of the exchange device has been advanced through the guidewire port and well within the short guidewire receiving inner lumen which extends within the distal portion of the readily exchangeable catheter. Once the distal end of the guidewire exchange device is seated within the guidewire port, the in-place guidewire can then be withdrawn proximally
5 from the catheter and the patient's arterial system by pulling on the proximal end of the guidewire which extends out of the patient. A replacement guidewire may then be advanced through the inner lumen of the exchange device, through the proximal guidewire port in the dilatation catheter and through the inner lumen of the catheter until the guidewire extends out the distal guidewire port in the dilatation catheter.

10

In the embodiment of the invention wherein the distal portion of the distal tubular member of the exchange device is adapted to be inserted into and be advanced through essentially the entire length of the relatively short guidewire receiving inner lumen of the readily exchangeable catheter is particularly suitable for use with a rapid exchange
15 type dilatation catheters having perfusion ports, as described in the previously discussed McInnes *et al.* applications incorporated herein, which allow blood to pass through the guidewire receiving inner lumen. When using rapid exchange type dilatation catheters with perfusion holes in the catheter shaft, advancement of a replacement guidewire within the guidewire receiving inner lumen sometimes results in the passage of the guidewire out
20 one of the perfusion holes in the catheter wall rather than the guidewire port in the distal end of the catheter. When the distal extremity of the guidewire exchange device of the invention is positioned within the guidewire receiving inner lumen of the readily exchangeable catheter, the replacement guidewire is directed to the distal guidewire port and cannot be advanced out one of the perfusion holes.

The construction of the junction between the distal and proximal sections can be used in a variety of intraluminal and intravascular devices including readily exchangeable dilatation catheters such as described in the aforementioned Yock and Horzewski *et al.* patents.

5

These and other advantages of the invention will become more apparent from the following detailed description thereof when taken in conjunction with the accompanying exemplary drawings.

10

BRIEF DESCRIPTION OF THE DRAWINGS

FIG. 1 is an elevational view of the exchange device of the invention.

FIG. 2 is an enlarged elevational view in longitudinal section of the junction
15 between the distal and proximal tubular members of the exchange device taken along the lines 2-2 shown in FIG. 1.

20

FIG. 3 is a transverse cross-sectional view taken along the lines 3-3 shown in FIG. 1.

FIG. 4 is a transverse cross-sectional view taken along the lines 4-4 shown in FIG. 1.

FIG. 5. is an elevational view of a guiding catheter and a readily

exchangeable dilatation catheter with a guidewire exchange device having features of the invention.

FIG. 6 is an enlarged view of the section of the assembly shown in FIG. 5
5 which is encircled by the ellipse 6.

FIGS. 7-14 illustrate the exchange of a guidewire utilizing the exchange device shown in FIGS. 1-4.

10 FIG. 15 is an enlarged longitudinal cross-sectional view similar to FIG. 6 of an alternate embodiment of the invention used with a dilatation catheter which has the capability of perfusing blood distal to the catheter upon the inflation of the balloon.

DETAILED DESCRIPTION OF THE INVENTION

15

Reference is made to FIGS. 1-4 which depict a guidewire exchange device
10 embodying features of the invention. The exchange device 10 includes a relatively long proximal tubular section 11, a relatively short distal tubular section 12 and an outer sleeve 13 bonded at the junction between the proximal and distal tubular sections to the ends
20 thereof. As shown in Fig. 2 the larger proximal end of the outer sleeve 13 defines a proximal guidewire port 14 communicating with the portion of the guidewire-receiving inner lumen 15 which extends within the distal tubular section 12 through a passageway 16. The distal tip 17 of the exchange device 10 may be beveled or tapered as shown to facilitate the entry thereof into the proximal guidewire port of a readily exchangeable

catheter.

The proximal tubular section 11 is relatively stiff in comparison to the distal tubular section 12 to provide a high degree of pushability to the catheter. As shown in Fig. 3, the proximal tubular section is formed of hypotubing 18 and a coating or jacket 19 of plastic material which is secured to the exterior of the hypotubing. The hypotubing is provided with a slit 20 having a width in excess of the maximum transverse dimension of the replacement guidewire 21 (shown in phantom) to be used and the jacket with a slit 22 having a much smaller spacing. This allows the replacement guidewire 21 to be stripped from the inner lumen 23 of the proximal section 11 after it has been advanced into the distal section 12. Preferably, a Luer adapter 24 is mounted to the proximal end of the proximal tubular section 11 and is either removable or is provided a slit continuous with slits 20 and 21 to facilitate removal of the replacement guidewire 21 from the inner lumen 25 in the proximal tubular section 11.

15

Fig. 4 illustrates a transverse cross-sectional view of the proximal tubular section 12 which is a relative flexible section formed of suitable plastic material.

FIG. 5 depicts a dilatation catheter assembly which includes a guiding catheter 26, a readily exchangeable dilatation catheter 27, an in-place guidewire 28, a replacement guidewire 21 and the guidewire exchange device 10. In practice, an adapter (not shown) would be provided on the proximal end of the guiding catheter which has a hemostatic valve large enough to accommodate the guidewire, the dilatation catheter and the exchange device.

The area enclosed by the ellipse 6 shown in FIG. 5 is depicted in an enlarged cross-sectional view in FIG. 6. The distal tip of the exchange device 10 is shown seated within the proximal guidewire port 29 of the dilatation catheter 27. A first guidewire 29 is in-place within the guidewire receiving inner lumen 30 of the dilatation catheter 27 and extends through the inner lumen 15 of the guidewire exchange device 10, the passageway 16 and the proximal port 14. The sleeve 13 is preferably enlarged at its proximal extremity and slightly angled as shown, e.g. about 5 to about 40 degrees, preferably about 5 to about 30 degrees, so that the guidewire passes straight through the passageway 16 and proximal port 14 when the guidewire is advanced proximally through the inner lumen 15 in the distal section 12. There is little or no tendency for the guidewire to advance into the inner lumen 25. A second or replacement guidewire 21 is shown in phantom disposed within the inner lumen 25 within the proximal tubular section 11.

The exchange of an in-place guidewire 28 with a replacement guidewire 21 is illustrated in the sequence of FIGS. 7-14. As shown in FIG. 7, the in-place guidewire is disposed within the short guidewire receiving inner lumen 30 (not shown) in the distal section of the readily exchangeable dilatation catheter 27. Both the in-place guidewire 28 and the dilatation catheter 27 are disposed within a guiding catheter 26, as shown in FIG. 5 with the distal end of the dilatation catheter extending out the distal end of the guiding catheter. As discussed in the Background of the Invention, the distal end of the guiding catheter 26 is seated within the ostium of the patient's coronary artery during the angioplasty procedure so as to guide the guidewires and dilatation catheters into the patient's coronary anatomy.

The proximal end of the in-place guidewire is inserted, *i.e.* back-loaded, into the distal port of the guidewire exchange device 10 and through the inner lumen 15 and passageway 16 until the proximal end exits the proximal port 14 at the junction between the proximal and distal tubular sections 11 and 12. The proximal end of the guidewire may then be manually grasped and the exchange device 10 advanced, as shown in FIG. 8, over the in-place guidewire 28 until the distal tip of the exchange device is seated within the proximal guidewire port 29 in the readily exchangeable dilatation 27, as shown in FIG. 9. At this point the in-place guidewire 28 may be withdrawn from the dilatation catheter 27 and the patient as shown by the arrow in FIG. 10. The distal end of a replacement guidewire 21 is advanced through the adapter 24 as shown in FIG. 11 and the inner lumens 15 and 25 of the exchange device 10 and out the tapered distal end 17 thereof which is seated within the guidewire port 29 of the easily exchangeable dilatation catheter 27. As shown in FIG. 5 the replacement guidewire 21 may be positioned within the inner lumen 25 before the in-place guidewire 28 is removed. The advancement of the replacement guidewire 21 continues until the distal tip thereof extends out the distal end of the dilatation catheter 27 into the patient's coronary artery. The exchange device may then be removed from the patient. As the guidewire exchange device is withdrawn from the patient, it is stripped from the replacement guidewire 21 through slits 20 and 21 in the proximal section 11 as shown in FIG. 14. When the guidewire exchange device is withdrawn completely from the patient so that the replacement guidewire 21 extends out the proximal port 14 and bare guidewire 21 is visible extending out the distal end 17 of the exchange device, the exposed guidewire distal to the distal end 17 can be manually grasped to hold the guidewire in position while the exchange device is removed therefrom.

The readily exchangeable dilatation catheter 27 can be exchanged for another readily exchangeable dilatation catheter over either the in-place guidewire 28 or the replacement guidewire 21.

5 The procedure for a readily exchangeable dilatation catheter with perfusion ports proximal and distal to the inflatable member or balloon on the distal portion of the catheter is essentially the same as illustrated in FIGS. 7-14 except that the distal section 12 of the guidewire exchange device 10 extends well into the inner lumen 30 as shown in FIG. 15 to ensure that the guidewire does not divert out one of the perfusion ports 31
10 when the guidewire is advanced through the inner lumen 30.

 The overall length of the guidewire exchange device is typically about 85 to about 130 cm. The transverse dimensions are for the most part controlled by the maximum transverse dimension of the guidewires to be used but they generally range from
15 about 0.03 to about 0.05 inch (0.76-1.3 mm) in outer diameter. The length of the distal section can range from about 1 to about 40 cm, but preferably ranges from about 7 to about 20 cm. The hypotubing of the proximal section 11 can be formed of stainless steel or a superelastic NiTi alloy and the jacket can be a low density polyethylene. The distal section 12 and the sleeve 13 may be formed of a high density polyethylene. The guiding
20 catheter, the dilatation catheter and the guidewires can be of conventional construction and materials.

 While the invention has been described herein in terms of a catheter device which facilitates guidewire replacement in a readily exchangeable dilatation catheter,

improved catheter construction can be employed in dilatation catheters such a readily exchangeable dilatation catheters. Those skilled in the art will recognize that other modifications and improvements can be made to the invention without departing from the scope thereof.

WHAT IS CLAIMED:

1 1. A guidewire exchange device comprising an elongated shaft having proximal
2 and distal ends, and a guidewire receiving inner lumen extending therein at least from a
3 proximal guidewire port to a distal guidewire port in the distal end thereof, the distal end
4 of the shaft being adapted to be inserted into a guidewire port in a rapid exchange type
5 dilatation catheter.

1 2. The guidewire exchange device of claim 1 wherein the proximal guidewire
2 port in the catheter shaft is spaced proximally at least about 1 cm from the distal guidewire
3 port of the catheter shaft.

1 3. The guidewire exchange device of claim 1 wherein a guidewire passageway
2 extends between the proximal guidewire port and the guidewire receiving inner lumen
3 extending within the distal section of the exchange device.

1 4. The guidewire exchange device of claim 3 wherein the guidewire
2 passageway is in-line with the guidewire receiving inner lumen which extends within the
3 distal section of the exchange device.

1 5. The guidewire exchange device of claim 1 wherein the most distal portion
2 of the catheter shaft is adapted to be inserted through the proximal guidewire port of a
3 rapid exchange type dilatation catheter having perfusion ports between the proximal

4 guidewire port and the inflatable member thereof and be advanced within a guidewire
5 receiving inner lumen which extends between the proximal guidewire port and the distal
6 guidewire port in the dilatation catheter.

1 6. A balloon dilatation catheter kit comprising:

- 2 a) a balloon dilatation catheter having an elongated shaft with an
3 inflatable balloon on the distal portion thereof and a guidewire-receiving inner
4 lumen which extends from a distal guidewire port in the distal end of the dilatation
5 catheter to a proximal guidewire port spaced proximally from the distal guidewire
6 port and a substantial distance distally from the proximal end of the elongated
7 shaft; and
- 8 b) a guidewire exchange device having an elongated shaft with an inner
9 lumen extending therein, a distal guidewire port in the distal end of the exchange
10 device and a proximal guidewire port spaced at least 1 cm from the distal end of
11 the exchange device, the distal end of the guidewire exchange device being shaped
12 and dimensioned to enter the proximal guidewire port of the dilatation catheter.

1 7. The kit of claim 6 wherein perfusion ports are provided in the elongated
2 shaft of the balloon dilatation catheter proximal and distal to the balloon in communication
3 with the guidewire-receiving inner lumen.

1 8. The kit of claim 7 wherein the distal portion of the guidewire exchange
2 device is dimensioned to slide over a guidewire disposed within the guidewire-receiving
3 inner lumen, through the proximal guidewire port and into the guidewire-receiving inner

4 lumen.

1 9. The kit of claim 6 including a guidewire having an elongated core and a
2 flexible body on the distal portion thereof and adapted to be disposed at least partially
3 within the guidewire receiving inner lumen of the dilatation catheter.

1 10. A method for exchanging a guidewire during an angioplasty procedure
2 wherein a readily exchangeable dilatation catheter having a short guidewire receiving inner
3 lumen in the distal portion thereof extending between a distal guidewire port in the distal
4 end of the dilatation catheter and a proximal guidewire port spaced at least 10 cm from the
5 distal guidewire port, is disposed within a patient's vasculature and wherein a first
6 guidewire having proximal and distal ends extends through the short guidewire receiving
7 inner lumen within the distal portion of dilatation catheter, the method comprising:

8 a) providing a guidewire exchange device comprising an elongated shaft
9 with a guidewire receiving inner lumen extending therein, a distal guidewire port
10 in the distal end of the exchange device and a proximal guidewire port spaced at
11 least 10 cm from the distal end of the exchange device, both of said guidewire
12 ports being in fluid communication with the inner lumen of the exchange device,
13 and the distal end of the guidewire exchange device being adapted to enter the
14 proximal guidewire port of the dilatation catheter;

15 b) mounting the guidewire exchange device onto the proximal end of
16 the first guidewire;

17 c) advancing the guidewire exchange device over the first guidewire
18 until the distal end of the exchange device enters into the proximal guidewire port

- 19 of the dilatation catheter;
- 20 d) withdrawing the first guidewire through the guidewire exchange
21 device by pulling the first guidewire from its proximal end; and
- 22 f) advancing a second guidewire through the inner lumen of the
23 guidewire exchange device, through the short guidewire receiving inner lumen in
24 - distal extremity of the dilatation catheter and out the distal end thereof.

- 1 11. A balloon dilatation catheter assembly comprising:
- 2 a) a balloon dilatation catheter having an elongated shaft with an
3 inflatable balloon on the distal portion thereof and a guidewire-receiving inner
4 lumen which extends between a distal guidewire port in the distal end of the
5 dilatation catheter and a proximal guidewire port spaced at least 10 cm from the
6 distal guidewire port;
- 7 b) an guidewire having an elongated core and a flexible body on the
8 distal portion thereof and being disposed at least partially within the guidewire
9 receiving inner lumen of the dilatation catheter; and
- 10 c) a guidewire exchange device having an elongated shaft with an inner
11 lumen extending therein, a distal guidewire port in the distal end of the exchange
12 device and a proximal guidewire port spaced at least 10 cm from the distal end of
13 the exchange device, the distal end of the guidewire exchange device being
14 dimensioned to be seated within the proximal guidewire port of the dilatation
15 catheter.

- 1 12. The assembly of claim 11 wherein the elongated shaft of the balloon

2 dilatation catheter has perfusion ports which are located proximal and distal to the balloon
3 and which are in fluid communication with the guidewire-receiving inner lumen.

1 13. The assembly of claim 12 wherein the guidewire exchange device is
2 dimensioned to slide over a guidewire disposed within the guidewire-receiving inner
3 lumen, through the proximal guidewire port and the guidewire-receiving inner lumen.

1 14. A method for exchanging a guidewire disposed within a short guidewire
2 receiving inner lumen in the distal portion of an intravascular catheter which is placed
3 within a patient during an intravascular procedure comprising:

4 a) providing a guidewire replacement device which has a proximal
5 tubular section having proximal and distal ends, and a distal tubular section having
6 proximal and distal ends, with the proximal end of the distal tubular section being
7 secured to the distal end of the proximal tubular section and having a proximal
8 guidewire port and with the distal end of the distal tubular section having a distal
9 guidewire port and being adapted to be seated into a proximal guidewire port of an
10 intravascular catheter;

11 b) advancing the guidewire replacement device over the guidewire until
12 the distal end of the guidewire replacement device is seated within the proximal
13 guidewire port in the catheter through which the guidewire exits;

14 c) withdrawing the in-place guidewire;

15 d) advancing a replacement guidewire through an inner lumen extending
16 within the guidewire replacement device, through the proximal guidewire port in
17 the catheter and out the distal guidewire port in the catheter;

- 18 e) withdrawing the guidewire replacement device from the patient;
- 19 f) peeling the guidewire replacement device from the replacement
20 guidewire through a slit provided in the wall of the proximal tubular section of the
21 guidewire replacement device as it exits the patient; and
- 22 g) further withdrawing the guidewire placement device over the
23 replacement guidewire until the distal end of the placement device exits the patient,
24 manually securing the exposed portion of the replacement guidewire distal to the
25 distal end of the placement device and then removing the placement device from
26 the replacement guidewire.

1 15. An intraluminal catheter adapted to exchange an in-place guidewire with a
2 replacement guidewire, comprising:

- 3 a) an elongated shaft having a proximal section with an inner lumen
4 extending therein and a distal section with an inner lumen extending therein;
- 5 b) a junction between the proximal and distal shaft sections which
6 includes a proximal guidewire port which is in communication with the inner lumen
7 of the distal shaft section and which is offset from the inner lumen in the proximal
8 shaft section.

1 16. The catheter of claim 15 wherein the distal and proximal shaft sections are
2 disposed at a slight angle with respect to one another.

1 17. The catheter of claim 15 wherein the distal and proximal shaft sections are
2 separate tubular elements and the junction therebetween includes a sleeve having a distal

3 end secured to the proximal end of the tubular element forming the distal shaft section and
4 an enlarged proximal end which is partially secured to the distal end of the tubular element
5 forming the proximal shaft section and which defines the proximal guidewire port.

1 18. The catheter of claim 16 wherein the angle is about 5 to about 40 degrees.

1 19. The catheter of claim 18 wherein the angle is not more than about 30
2 degrees.

FIG. 1

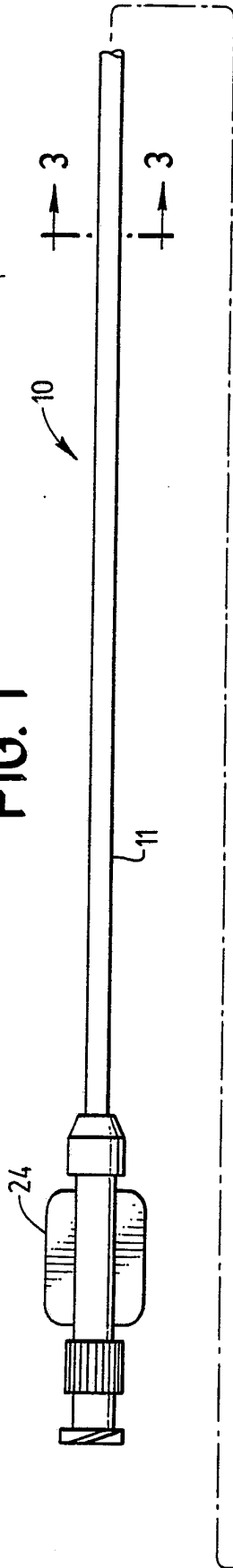

SUBSTITUTE SHEET

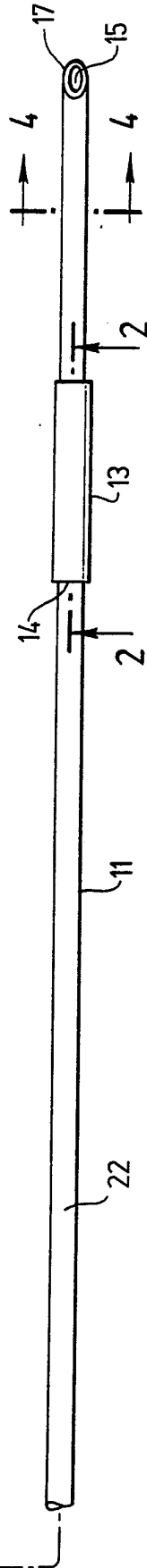

FIG. 3

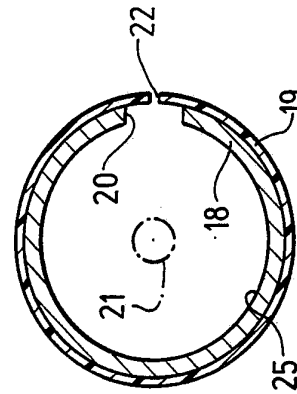

FIG. 4

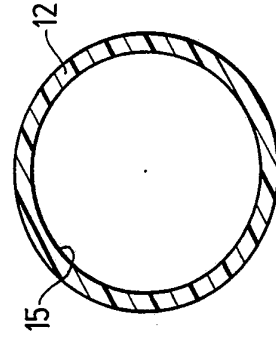
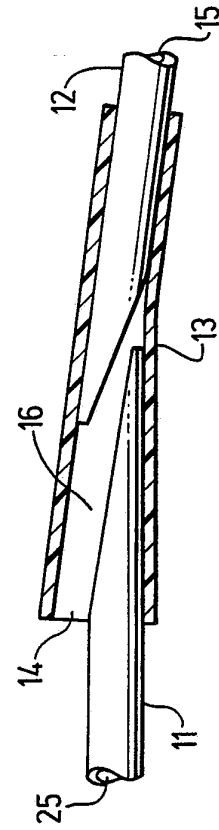

FIG. 2



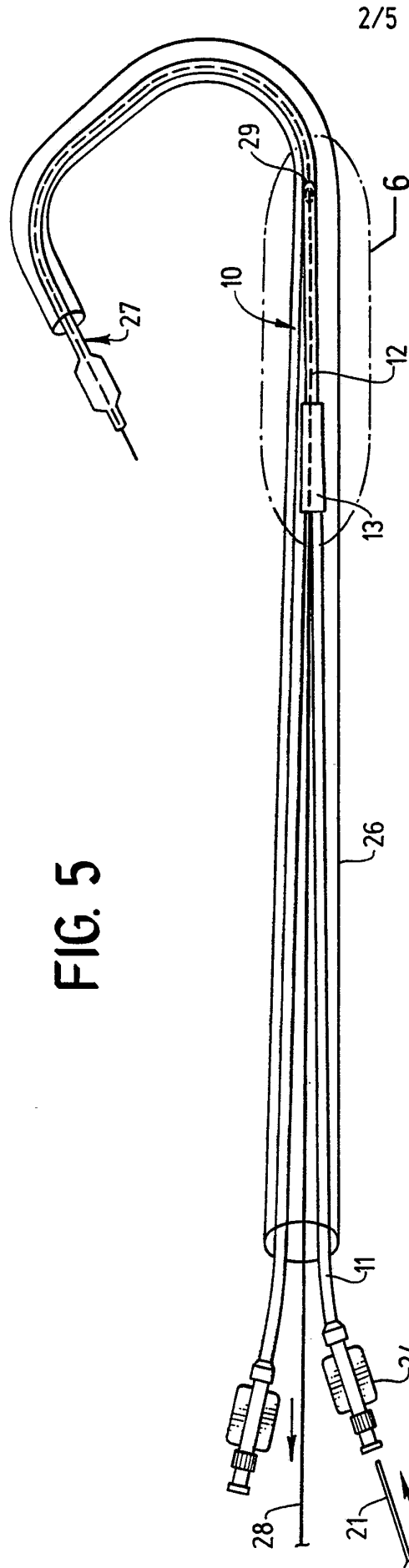

FIG. 6

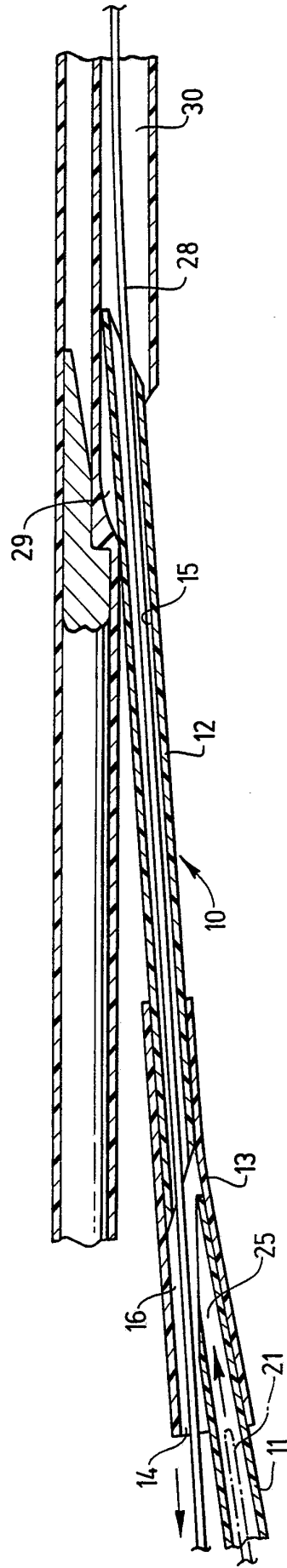

FIG. 7

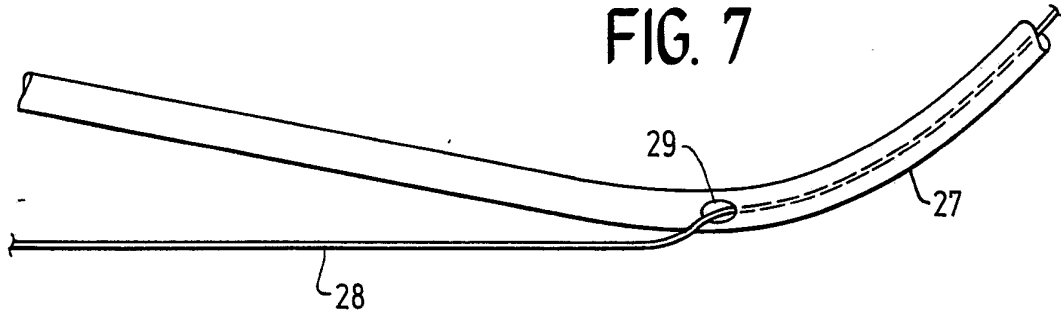

FIG. 8

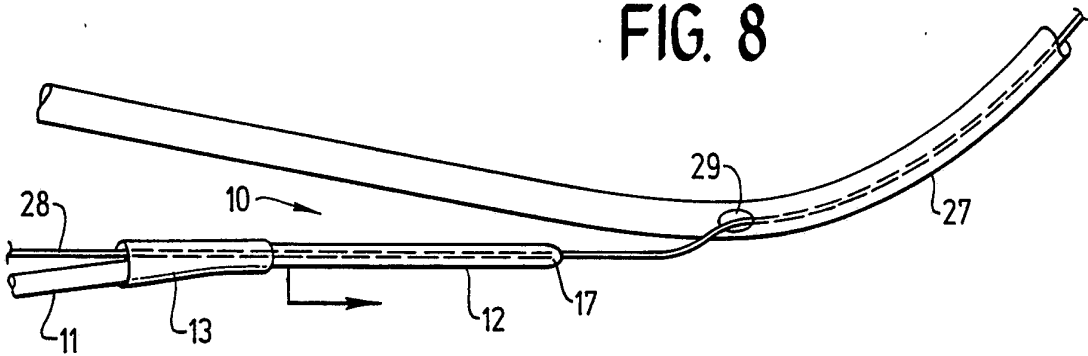

FIG. 9

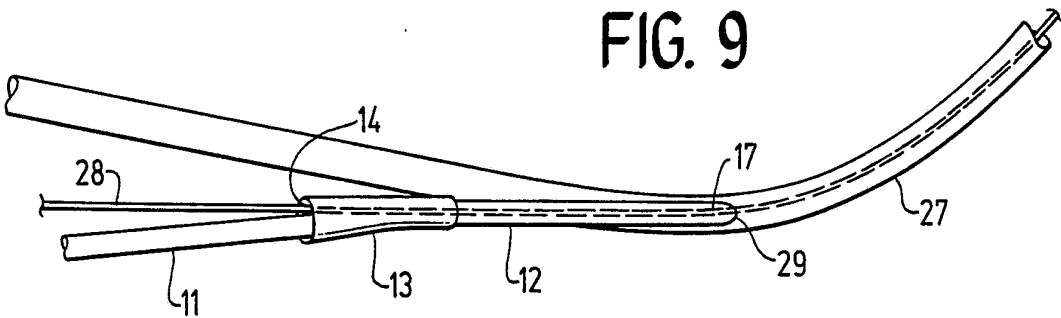

FIG. 10

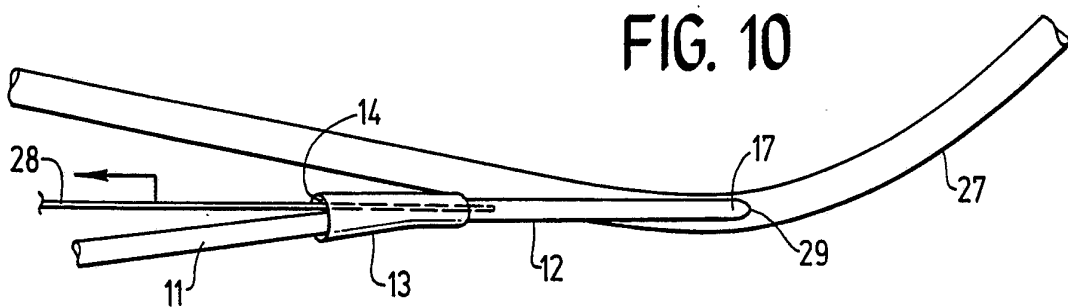

FIG. 11

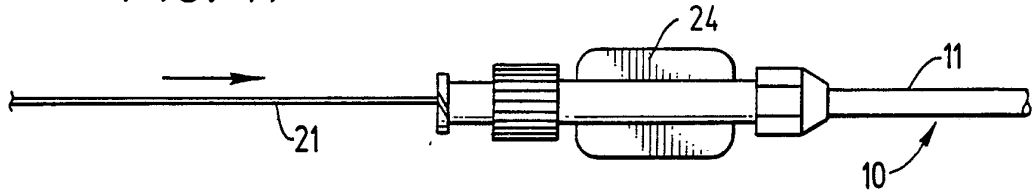

FIG. 12

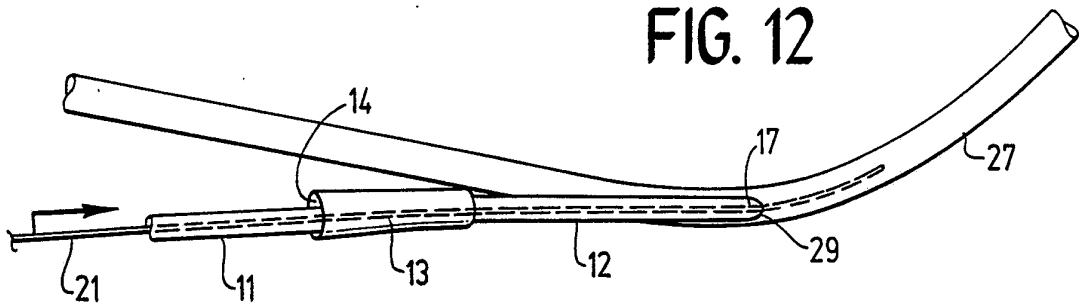

FIG. 13

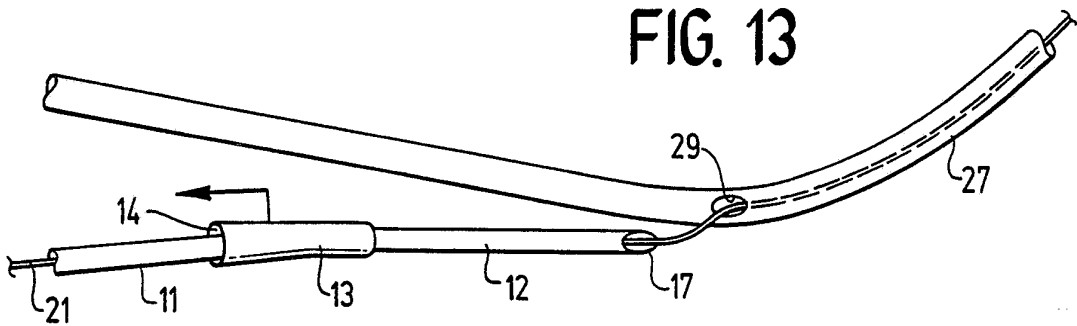

FIG. 14

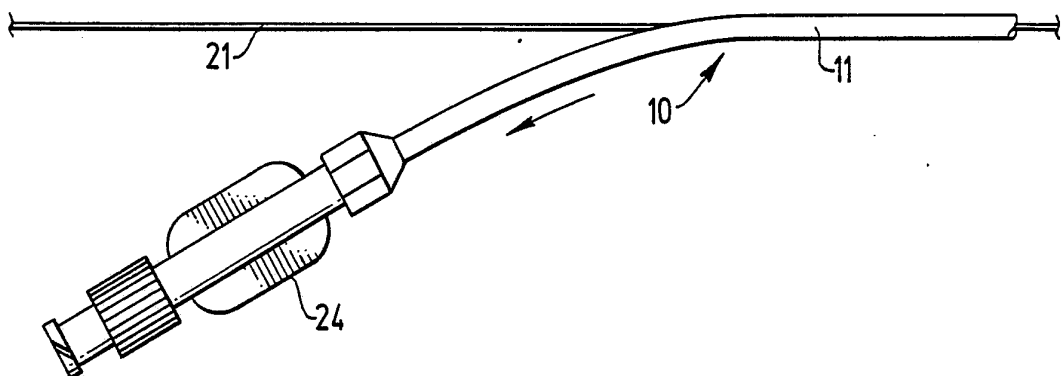
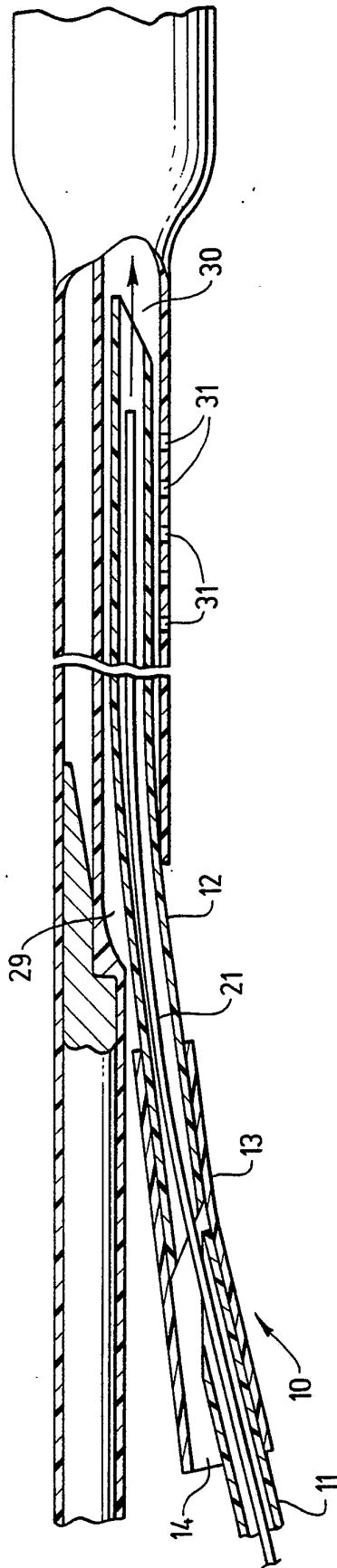

FIG. 15



INTERNATIONAL SEARCH REPORT

International application No.
PCT/US93/00067

A. CLASSIFICATION OF SUBJECT MATTER		
IPC(5) :A61M 29/02 US CL :606/194 According to International Patent Classification (IPC) or to both national classification and IPC		
B. FIELDS SEARCHED		
Minimum documentation searched (classification system followed by classification symbols) U.S. : 606/192,1; 604/96,284		
Documentation searched other than minimum documentation to the extent that such documents are included in the fields searched		
Electronic data base consulted during the international search (name of data base and, where practicable, search terms used)		
C. DOCUMENTS CONSIDERED TO BE RELEVANT		
Category*	Citation of document, with indication, where appropriate, of the relevant passages	Relevant to claim No.
X	US,A, 4,661,110 (FORTIER ET AL) 28 APRIL 1987 See entire document	1-5,15-19
X	US,A, 4,988,356 (CRITTENDEN ET AL) 29 JANUARY 1991 See entire document	6-9,11-13
<input type="checkbox"/> Further documents are listed in the continuation of Box C. <input type="checkbox"/> See patent family annex.		
A	Special categories of cited documents: document defining the general state of the art which is not considered to be part of particular relevance	*T* later document published after the international filing date or priority date and not in conflict with the application but cited to understand the principle or theory underlying the invention
E	earlier document published on or after the international filing date	*X* document of particular relevance; the claimed invention cannot be considered novel or cannot be considered to involve an inventive step when the document is taken alone
L	document which may throw doubts on priority claim(s) or which is cited to establish the publication date of another citation or other special reason (as specified)	*Y* document of particular relevance; the claimed invention cannot be considered to involve an inventive step when the document is combined with one or more other such documents, such combination being obvious to a person skilled in the art
O	document referring to an oral disclosure, use, exhibition or other means	*Z* document member of the same patent family
P	document published prior to the international filing date but later than the priority date claimed	
Date of the actual completion of the international search 02 MARCH 1993		Date of mailing of the international search report 27 APR 1993
Name and mailing address of the ISA/US Commissioner of Patents and Trademarks Box PCT Washington, D.C. 20231 Facsimile No. NOT APPLICABLE		Authorized officer <i>Deane Goodhue Jr</i> MICHAEL THALER Telephone No. (703) 308-2981