

July 19, 1966

3,261,901

GEORG KOPP ALSO KNOWN AS JÖRG KOPP

METHOD OF MOLDING A SHOULDER ON A VERTICAL MANDREL

Filed April 1, 1963

4 Sheets-Sheet 1

Fig. 1

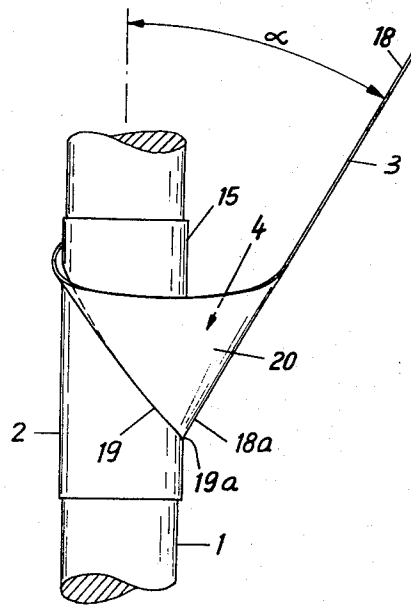
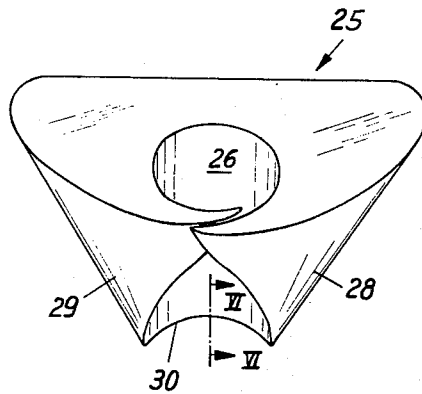

Fig. 4



July 19, 1966

3,261,901

GEORG KOPP ALSO KNOWN AS JÖRG KOPP

METHOD OF MOLDING A SHOULDER ON A VERTICAL MANDREL

Filed April 1, 1963

4 Sheets-Sheet 2

Fig. 2

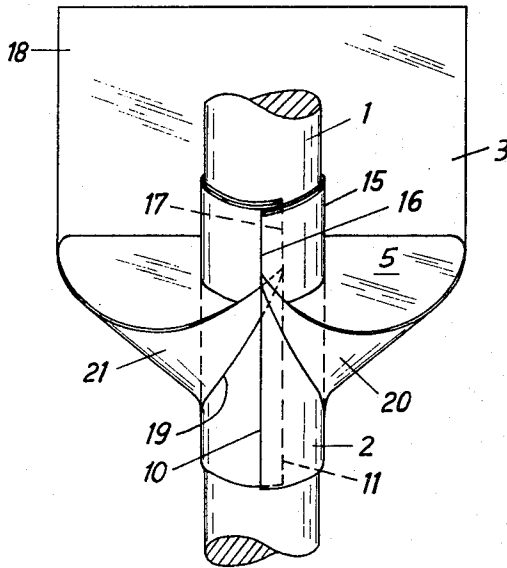
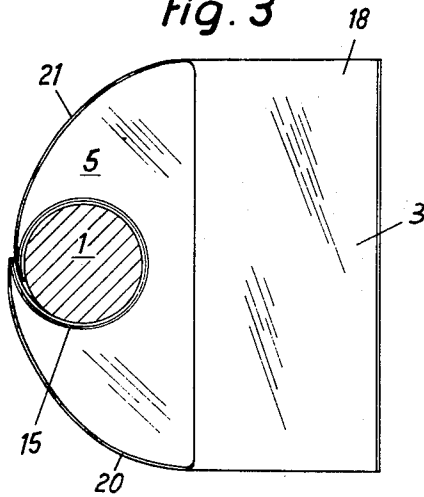

Fig. 3



July 19, 1966

3,261,901

GEORG KOPP ALSO KNOWN AS JÖRG KOPP

METHOD OF MOLDING A SHOULDER ON A VERTICAL MANDREL

Filed April 1, 1963

4 Sheets-Sheet 3

Fig. 5

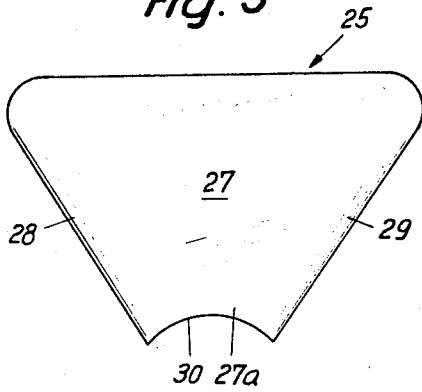

Fig. 6

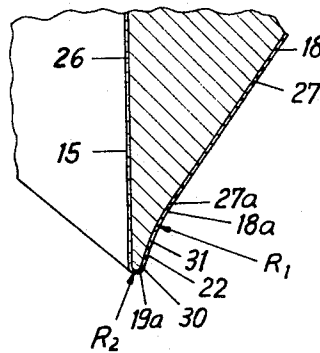
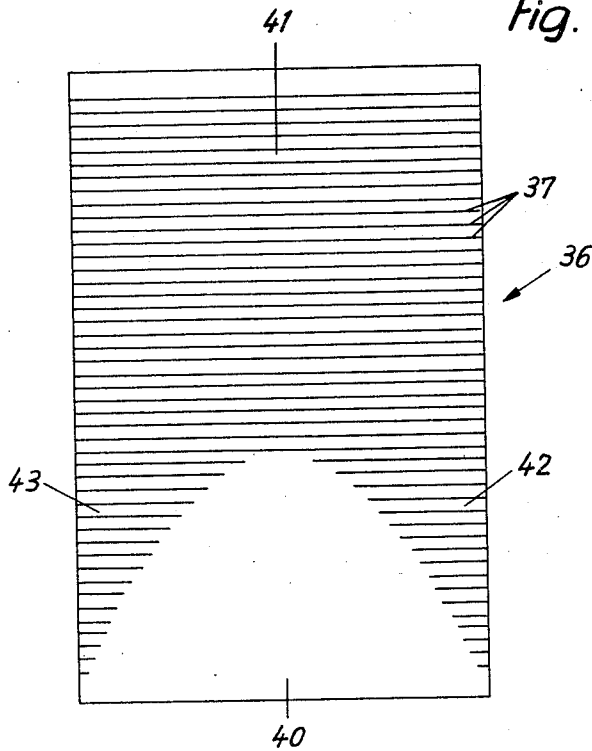

Fig. 8



July 19, 1966

3,261,901

GEORG KOPP ALSO KNOWN AS JÖRG KOPP

METHOD OF MOLDING A SHOULDER ON A VERTICAL MANDREL

Filed April 1, 1963

4 Sheets-Sheet 4

Fig. 9

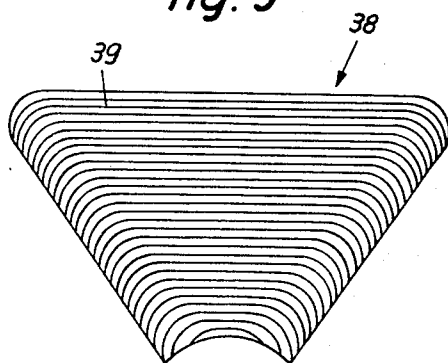
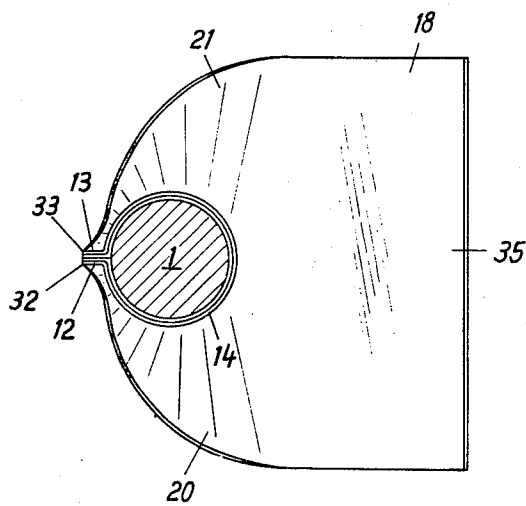

Fig. 7



1

3,261,901

METHOD OF MOLDING A SHOULDER ON A VERTICAL MANDREL

Georg Kopp, also known as Jörg Kopp, Schaffhausen, Switzerland, assignor to Schweizerische Industrie-Gesellschaft, Neuhausen am Rheinfall, Switzerland

Filed Apr. 1, 1963, Ser. No. 269,676

Claims priority, application Switzerland, Apr. 3, 1962, 4,039/62

9 Claims. (Cl. 264—219)

The present invention relates to formers for use in making tubes from strip material, such as cardboard, supplied from a roll.

Packaging machinery is often constructed wherein a packing tube is formed from a strip of material running off a roll, and this tube is then filled and processed into individual packages. For this purpose, the strip of material is folded round a mandrel, a former or so-called forming shoulder guiding the strip through an angle greater than 270° onto the mandrel. Such a forming shoulder has an interior concave cylindrical surface extending through it from one end to an opposite end, such cylindrical surface being of slightly larger diameter than the mandrel. One edge of the cylindrical surface forms a folding edge curving smoothly from each side of a central portion thereof at the rear of the forming shoulder to the front of the shoulder and towards the opposite edge of the cylindrical surface. A flat exterior rear surface of the shoulder is inclined at an acute angle to the axis of the cylindrical surface and extends to said central rear portion of the folding edge whilst convex exterior curvilinear side surfaces blend with the flat rear surface and extend therefrom forwardly to the remaining portions of the folding edge. The strip material is fed along the flat surface and over the curvilinear surfaces to the folding edge. At the folding edge the material is bent through a sharp angle (over 270°) and passes as a tube through the annular clearance space between the internal cylindrical surface and the mandrel which extends through the bore formed by this cylindrical surface.

These forming shoulders have hitherto been hand made of metal by skilled craftsmen. This is very time consuming and therefore expensive and furthermore is subject to inaccuracies which may prevent the strip of material running smoothly over the forming shoulder.

The invention concerns a forming shoulder for the above stated purpose and a process by means of which these forming shoulders may be produced more quickly, more cheaply and above all more accurately than has hitherto been possible.

According to one aspect of the present invention, a method of making a forming shoulder includes the steps of arranging a cylindrical mandrel with its axis generally vertical; folding a foil in strip form about the cylindrical mandrel so that one end part of said foil is in tubular form about said mandrel, the other end portion of the foil is flat and inclined downwardly to the axis of the mandrel at the same angle as the strip material to be formed into a tube will be fed and the foil takes the general shape which will be assumed by the strip material being folded, a mould cavity thereby being formed about the foil portion in the form of a tube; casting a settable composition into said mould cavity to form a cast body; and removing said foil from said cast body to provide a forming shoulder.

Preferably the mandrel is enclosed by a sleeve which is covered with adhesive on the outside and the adhesive sleeve is covered by the tubular portion of the foil. Said composition cast into the mould cavity is preferably one which solidifies practically without shrinkage.

According to another aspect of the invention, a forming shoulder for forming strip material into a tube about a cylindrical mandrel has an interior concave cylindrical

2

surface in a hole extending through said shoulder, one edge of said cylindrical surface being radiused to provide a folding edge which curves smoothly upwardly from each side of a central portion thereof at the rear of said shoulder to the front of said shoulder, a flat exterior rear surface inclined at an acute angle to the axis of said cylindrical surface and extending towards said central rear portion of said folding edge, convex exterior curvilinear side surfaces blending with said flat rear surface and extending therefrom towards said folding edge and an exterior border surface adjoining said radiused folding edge, said border surface blending with said curvilinear side surfaces and with said flat rear surface, and being slightly curved concave to said folding edge.

The method of producing the forming shoulder and the shoulder itself will be further described by way of example with reference to the accompanying drawings wherein:

FIG. 1 is a side view of a folding mandrel around which is arranged a flexible foil which is folded to the form of a strip of material which is to be folded into a tube as it is being guided over the forming shoulder.

FIG. 2 is a front perspective view of the mandrel and the foil, the cavity in the foil having been filled with a settable composition;

FIG. 3 is a plan view corresponding to FIG. 2.

FIG. 4 is a front perspective view of the forming shoulder which has been cast in the cavity.

FIG. 5 is a rear perspective view of the shoulder;

FIG. 6 is section to a larger scale through the folding edge of the forming shoulder on the line VI—VI in FIG. 4;

FIG. 7 is a plan view similar to FIG. 2, but of another embodiment before the cavity is filled;

FIG. 8 shows an aluminum foil provided with transverse ridges; and

FIG. 9 is a rear perspective view of a shoulder cast in a cavity formed by the ribbed foil of FIG. 8;

Referring to the drawings and more particularly to FIGS. 1 to 4, a mandrel 1, which is either the mandrel used in a packaging machine itself or a mandrel of the same diameter, is enclosed by a cardboard sleeve 2 which is covered with adhesive on the outside. If the packaging tube which is to be produced by means of the forming shoulder to be made is to have an overlapping longitudinal seam, then the longitudinal edges 10, 11 of the cardboard sleeve will also be made to overlap, as shown in FIGS. 2 and 3.

A piece of flexible foil 3 having a very smooth surface, for example, an aluminum foil, is now secured to the adhesive outer surface of the cardboard sleeve 2 in such a manner that one end portion 15 of the foil is correctly formed into a tube. The foil 3 is preferably cut to the same width as the cardboard of the sleeve 2 so that when its end portion 15 is wound round the sleeve, its longitudinal edges 16, 17 will be flush with the overlapping longitudinal edges 10, 11 of the sleeve 2.

The lower end of the tubular or cylindrical portion 15 terminates a fold 19 which extends smoothly upwardly from a central rear portion 19a to the lateral edges 16 and 17.

The other end portion 18 of the foil 3, forms a flat rear portion at angle α to the axis of the mandrel 1, when the foil 3 is curved round the mandrel and extends downwardly inwardly towards the central rear fold portion 19a.

Curvilinear side portions 20 and 21 of the foil 3 blends with the flat rear portion 18 and extends forwardly and downwardly towards the bend 19. A cavity 4 is formed around the mandrel 1 and the sleeve 2 and since the foil 3 takes the shape of the strip of packaging material running into the packaging machine when it is being folded

into a tube, this cavity 4 formed by the foil 3 can be used as a mould cavity, for casting a forming shoulder.

A border file portion 22 (FIG. 6) adjoining the bend 19 blends with the curvilinear portions 20 and 21 and with the lowermost part 18a of the flat foil portion 18. The border portion is curved slightly concave downwardly towards the bend 19 with a radius R_1 . The bend 19 itself is not absolutely sharp but has a radius R_2 . The radii R_1 , and R_2 depend on the thickness of the aluminum foil, which may be about 0.08 to 0.10 mm. These radii of curvature vary over the whole length of the bend 19 and are determined by the balancing of the internal stresses in the foil 3, so that a practical ideal casting cavity is obtained.

The cavity 4 is now filled with a settable composition which solidifies without any marked shrinkage. Synthetic materials are preferably used for this purpose; for example acrylates, nylon and epoxy resins have been found satisfactory. The casting process may be carried out either by simply filling the cavity 4 up to its edge with liquid synthetic resin 5, as shown in FIGS. 2 and 3, in which case it may be advantageous to add filler to the synthetic resin, or the synthetic resin may be applied in layers or sprayed in or applied by some other suitable process.

When the synthetic resins 5 has solidified, the foil 3 and the sleeve 2 are removed to provide a forming shoulder 25. FIGS. 4 and 5 show a forming shoulder 25 produced as described above. This shoulder has an internal concave cylindrical surface 26, a flat rear surface 27 inclined to the axis of the cylindrical surface 26 at the angle α and curvilinear side surfaces 28 and 29 produced by the corresponding portions 15, 18, 20 and 21 of the foil 3. The curvilinear side surfaces 20 and 21 blend with the rear surface 18 and extend forwardly and downwardly towards a folding edge 30 forming the lower edge of the cylindrical surface 26. The flat rear surface 27 extends downwardly inwardly towards the folding edge 30. As shown in FIG. 6, which shows a detail of the forming shoulder before the removal of the foil, this shoulder has a border surface 31 adjoining the folding edge and blending with the curvilinear side portions 28 and 29 and with the lowermost part 27a of the flat portion 27. This border surface 31 is slightly concave downwardly towards the edge 30 with the radius R_1 , of the corresponding border portion 22 of the foil. Likewise the edge 30 itself has the radius R_2 of the corresponding bend 19 of the foil. As the cast forming shoulder has all the details of the cavity 4, the folding edge 30 considerably improves the guiding of the oncoming strip of packaging material compared with that achieved with the prior art forming shoulders, so that even packaging materials of extremely low stretchability, e.g. backed aluminum foils, can be worked by the forming shoulder perfectly satisfactorily and without any subsequent work on the forming shoulder.

The forming shoulder may either be fixed directly to the folding mandrel of the packaging machine or it may be used as a pattern for producing moulds from which any number of forming shoulders may be produced.

If desired, the foil 3 may be suitably treated, e.g. it may be reinforced from outside by means of synthetic resins or metals, so that it may itself be used as a master mould for the production of any number of forming shoulders.

The thickness of the cardboard used for the sleeve 2 may be selected according to the thickness of the strip of packaging material to be folded. If necessary, the mandrel 1 used for the production of the forming shoulder may have a slightly greater diameter than the mandrel used in the packing machine. Furthermore, the angle α may be adjusted to the thickness and type of packaging material. It is usually about 30° to 40°.

In cases wherein the packaging tube produced by the shoulder is to have a longitudinal seam which projects radially from the tube the longitudinal edges 12, 13 of

the cardboard sleeve 14 are arranged to project radially from the mandrel 1 as shown in FIG. 7. In this case also the longitudinal edges 32, 33 of the tubular portion 34 of the foil 35 are in register with the cardboard edges 12, 13. The foil shape of FIG. 7 is otherwise the same as that of FIGS. 1 to 3.

If a foil 36 provided with ridges 37 as shown in FIG. 8 is folded about the mandrel, the forming shoulder 38 produced by casting in the cavity formed by folding the foil about a mandrel as in FIGS. 1 to 3 will have corresponding ribs 39 which may, for example, run transversely to the direction in which the strip of packaging material is to move forward as shown in FIG. 9. Only the portion 40 of the foil 36 which is to be made tubular is free from ridges 39. Both that portion 41 which will remain flat and those portions 42 and 43 which are to become curvilinear are ridged. On the one hand, these ribs 39 considerably reduce the surface of contact and hence the frictional resistance of the strip and on the other hand, for example in the case of polyethylene, it reduces the electrostatic charge.

For the purpose of fixing the finished forming shoulder easily to a machine in accordance with its purpose the necessary mounting or securing members may advantageously be cast directly into the shoulder.

I claim:

1. In a method of shaping and molding a forming shoulder for forming strip material into a tube about a cylindrical mandrel: the steps of applying a cylindrical adhesive sleeve to said mandrel to form a support with its axis generally vertical; folding a flexible foil in strip form about the sleeve, bending said foil upwardly from its lower edge into the shape which will be assumed by the strip material being folded to form a mold wall offset from said mandrel axis, such shape including a tubular mold wall portion about said mandrel formed with a bend at the lower end of said tubular portion and formed by bending the foil upwardly, and a flat rear portion inclined upwardly from said bend at an acute angle to the mandrel axis towards said bend, said molds forming a mould cavity between said folded foil and said tubular foil portion; casting a settable composition into said mould cavity to form a cast body; permitting setting of said composition and removing said foil from said cast body to provide a forming shoulder.

2. The method according to claim 1 wherein said foil is aluminium foil.

3. In a method of shaping and molding a forming shoulder for forming strip material into a tube about a cylindrical mandrel: the steps of applying a cylindrical sleeve with its axis generally vertical; folding a flexible foil in strip form about said sleeve, bending said foil upwardly to form inner and outer mold walls and into the shape which will be assumed by the strip material being folded, such shape including a tubular portion about said mandrel forming said inner wall, the upwardly bending of the lower portion of said foil forming a bend at the lower end of said tubular portion, with a flat rear wall portion inclined upwardly from said bend at an acute angle to the mandrel axis away from said bend, said walls forming a mould cavity between said upwardly folded foil and said tubular foil portion; casting a settable composition into said mould cavity to form a cast body, said composition having the property that it is substantially non-shrinking upon solidification; and removing said foil from said cast body to provide a forming shoulder.

4. In a method of shaping and molding a forming shoulder for forming strip material into a tube about a cylindrical mandrel; the steps of positioning a cylindrical mandrel with its axis generally vertical; applying a sleeve to said mandrel; adhesively securing a strip of foil material to a portion of said sleeve, folding said foil in strip form about said sleeve, bending said foil upwardly from its lower end to form mold walls and of a shape after the strip material is folded, such shape including a tubu-

5

lar portion, a bend at the lower end of said tubular portion and a flat rear portion inclined upwardly from said bend at an acute angle to the mandrel axis, the bending of said foil forming a mould cavity in said folded foil about said tubular foil portion; casting a settable composition into said mould cavity to form a cast body; permitting said composition to set, and removing said foil from said cast body to provide a forming shoulder.

5. The method according to claim 4 wherein said sleeve is comprised of cardboard with a layer of adhesive on the outside thereof.

6. In a method of shaping and molding a forming shoulder for forming strip material into a tube about a cylindrical mandrel: the steps of arranging a cylindrical mandrel with its axis generally vertical; wrapping a foil in strip form about the cylindrical mandrel, folding the lower portion of said foil upwardly to form a cylindrical portion wrapped around said mandrel and an offset wall portion spaced therefrom, said cylindrical portion having a front longitudinal seam formed by juxtaposed lateral edge portions of the foil, bending the lower end of said cylindrical portion upwardly to form a mould cavity, said bend curving smoothly forwardly upwardly from each side of a central rear portion thereof to the lower end of said seam, a flat rear portion inclined at an acute angle to the mandrel axis downwardly towards said central rear portion of said bend and convex curvilinear portions blending with said flat rear portion and extending therefrom forwardly and downwardly to said bend, a mould cavity thereby being formed exteriorly of said cylindrical foil portion but interiorly of said flat rear and curvilinear side foil portions; filling a settable composition into said mould cavity, permitting setting in said mould cavity of said composition substantially without shrinkage to form a cast body; and finally removing said foil from said cast body to provide on said body the shape of a forming shoulder.

7. The method according to claim 6 wherein said foil, before it is deformed, is ridged at least over those regions which become said flat and curvilinear side portions, ribs thereby being formed over the corresponding surfaces of said cast body.

8. In a method of shaping and molding a forming shoulder for forming strip material into a tube about a cylindrical mandrel: the steps of arranging a cylindrical mandrel with its axis generally vertical; wrapping a foil in strip form about the cylindrical mandrel, folding the lower portion of said foil upwardly to form a cylindrical portion wrapped around said mandrel and an eccentric curved portion, said cylindrical portion having a front longitudinal seam formed by juxtaposed lateral edge portions of the foil, said folding step forming a radiused bend at the lower end of said cylindrical portion with said bend curving smoothly forwardly upwardly from each side of a central rear portion thereof to the lower end of said seam, said bending and folding step also forming a flat rear portion inclined at an acute angle to the mandrel axis downwardly towards said central rear portion of said bend

6

with convex curvilinear portions blending with said flat rear portion and extending therefrom forwardly and downwardly towards said bend and a border portion adjoining said bend, said foil being bent so that the same will form a border portion blending with said curvilinear side portions and being slightly curved concave downwardly to said bend, a mould cavity thereby being formed exteriorly of said cylindrical foil portion but interiorly of said flat rear, curvilinear side and border foil portions; filling a settable composition into said mould cavity, permitting said composition to set in said mould cavity substantially without shrinkage to form a cast body; and removing said foil from said cast body to provide on said body the shape of a forming shoulder.

9. In a method of shaping and molding a forming shoulder for forming strip material into a tube about a cylindrical mandrel: the steps of positioning a cylindrical mandrel with its axis generally vertical; applying a foil in strip form about the cylindrical mandrel, folding and bending said foil upwardly from its lower edge to form a cylindrical mold wall portion wrapped around said mandrel and an eccentric mold wall portion, said cylindrical portion having a front longitudinal seam formed by juxtaposed lateral edge portions of the foil, said folding step forming a bend at the lower end of said cylindrical portion curving smoothly forwardly upwardly from each side of a central rear portion thereof to the lower end of said seam with a flat rear portion inclined upwardly at an acute angle to the mandrel axis and downwardly towards said central rear portion of said bend with a convex curvilinear surface blending with said flat rear portion and extending therefrom forwardly and downwardly towards said bend and a border portion said bend and blending with said curvilinear side portions, said bend being radiused and said border portion being slightly curved concave downwardly to said bend in accordance with the thickness of the foil and said acute angle, a mould cavity, said folded and bent foil forming between said cylindrical foil portion and said outwardly and upwardly extending and folded curvilinear side and concave border foil portions; filling a settable composition into said mould cavity, permitting setting of said composition in said mould cavity to form a cast body; and removing said foil from said cast body to provide on said body the shape of a forming shoulder after said composition has set.

References Cited by the Examiner

UNITED STATES PATENTS

2,662,248	12/1953	Ames	264—219
2,708,773	5/1955	Bacon	264—219
2,810,935	10/1957	Gaydebouroff	264—219
3,122,072	2/1964	Monsees et al.	93—82
3,125,008	3/1964	Herdina	93—82

ROBERT F. WHITE, *Primary Examiner.*

BERNARD STICKNEY, *Examiner.*

R. B. MOFFITT, *Assistant Examiner.*