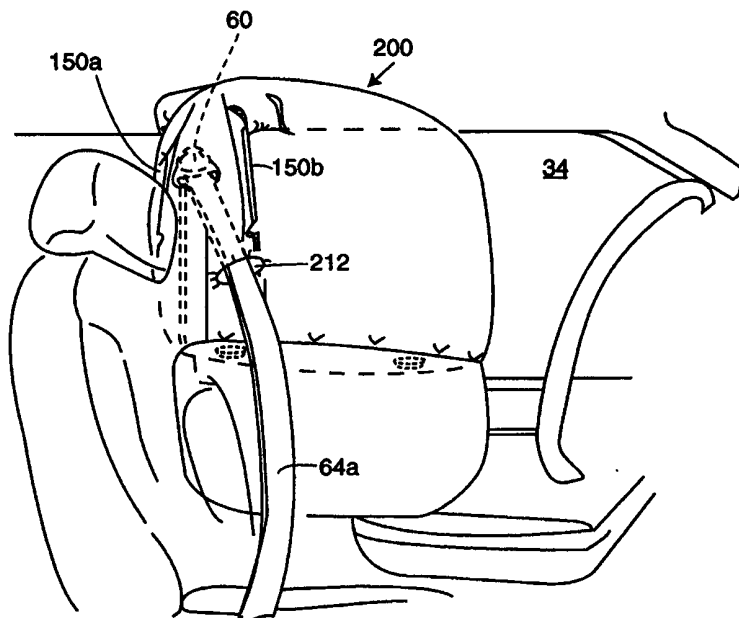


## INTERNATIONAL APPLICATION PUBLISHED UNDER THE PATENT COOPERATION TREATY (PCT)

<p>(51) International Patent Classification<sup>6</sup> : <b>B60R 21/18, 21/22</b></p>	<p><b>A1</b></p>	<p>(11) International Publication Number: <b>WO 99/42334</b></p> <p>(43) International Publication Date: 26 August 1999 (26.08.99)</p>
<p>(21) International Application Number: PCT/US99/01257</p> <p>(22) International Filing Date: 21 January 1999 (21.01.99)</p> <p>(30) Priority Data: 09/027,452                      21 February 1998 (21.02.98)      US</p> <p>(71) Applicant: BREED AUTOMOTIVE TECHNOLOGY, INC. [US/US]; P.O. Box 33050, Lakeland, FL 33807-3050 (US).</p> <p>(72) Inventors: LACHAT, Michael; 53450 Hunters Crossing, Shelby, MI 48315 (US). WIPASURAMONTON, Pongdet; 311 Elm Street, Rochester, MI 48307 (US). TOBIAN, Robert; 48571 Sugarbush Road, New Baltimore, MI 48047 (US). KUBIAK, Martin; 56703 Dickens Drive, Shelby Township, MI 48316 (US).</p> <p>(74) Agents: DRAYER, Lonnie, R.; Breed Automotive Technology, Inc., P.O. Box 33050, Lakeland, FL 33807-3050 (US) et al.</p>	<p>(81) Designated States: BR, CA, CZ, DE, GB, JP, KR, MX, PL, RU, European patent (AT, BE, CH, CY, DE, DK, ES, FI, FR, GB, GR, IE, IT, LU, MC, NL, PT, SE).</p> <p><b>Published</b> <i>With international search report.</i></p>	

(54) Title: PILLAR MOUNTED SIDE AIRBAG



(57) Abstract

A side impact crash protection system has a web guide (60) attached to a pillar of a vehicle. A seat belt system has a shoulder belt portion (64a) supported by and extending from the web guide (60). An airbag assembly includes an airbag (200) which is stored adjacent the web guide (60) and when deployed is positioned adjacent the pillar. The airbag (200) includes a channel (212) receiving a portion of the shoulder belt portion (64a).

**FOR THE PURPOSES OF INFORMATION ONLY**

Codes used to identify States party to the PCT on the front pages of pamphlets publishing international applications under the PCT.

AL	Albania	ES	Spain	LS	Lesotho	SI	Slovenia
AM	Armenia	FI	Finland	LT	Lithuania	SK	Slovakia
AT	Austria	FR	France	LU	Luxembourg	SN	Senegal
AU	Australia	GA	Gabon	LV	Latvia	SZ	Swaziland
AZ	Azerbaijan	GB	United Kingdom	MC	Monaco	TD	Chad
BA	Bosnia and Herzegovina	GE	Georgia	MD	Republic of Moldova	TG	Togo
BB	Barbados	GH	Ghana	MG	Madagascar	TJ	Tajikistan
BE	Belgium	GN	Guinea	MK	The former Yugoslav Republic of Macedonia	TM	Turkmenistan
BF	Burkina Faso	GR	Greece	ML	Mali	TR	Turkey
BG	Bulgaria	HU	Hungary	MN	Mongolia	TT	Trinidad and Tobago
BJ	Benin	IE	Ireland	MR	Mauritania	UA	Ukraine
BR	Brazil	IL	Israel	MW	Malawi	UG	Uganda
BY	Belarus	IS	Iceland	MX	Mexico	US	United States of America
CA	Canada	IT	Italy	NE	Niger	UZ	Uzbekistan
CF	Central African Republic	JP	Japan	NL	Netherlands	VN	Viet Nam
CG	Congo	KE	Kenya	NO	Norway	YU	Yugoslavia
CH	Switzerland	KG	Kyrgyzstan	NZ	New Zealand	ZW	Zimbabwe
CI	Côte d'Ivoire	KP	Democratic People's Republic of Korea	PL	Poland		
CM	Cameroon	KR	Republic of Korea	PT	Portugal		
CN	China	KZ	Kazakstan	RO	Romania		
CU	Cuba	LC	Saint Lucia	RU	Russian Federation		
CZ	Czech Republic	LI	Liechtenstein	SD	Sudan		
DE	Germany	LK	Sri Lanka	SE	Sweden		
DK	Denmark	LR	Liberia	SG	Singapore		
EE	Estonia						

**PILLAR MOUNTED SIDE AIRBAG**

The present invention generally relates to occupant safety restraint systems and more particularly to a system designed to protect a vehicle occupant in a side impact and/or rollover crash.

Providing safety systems to protect an occupant during a side impact crash or rollover crash has been proposed in the prior art. These systems include airbags that are stored within one or more of the vehicle doors and, when deployed, provide a cushion between the occupant and the side of the vehicle. Other systems deploy an airbag from a side or wing of the seat. Other systems deploy a net or airbag that is typically stored near the roof rail of the vehicle and, when pulled down, covers the window area of the door to prevent occupant egress.

## BRIEF DESCRIPTION OF THE DRAWINGS

Fig. 1 diagrammatically illustrates the interior of a typical vehicle.

5 Fig. 2 illustrates a major component of the present invention in relation to the B-pillar.

Fig. 3 is an assembly view showing the major components of the present invention.

10 Fig. 4 is a cross section of a housing of the present invention.

Fig. 5 is an isolated, plan view of an airbag.

Fig. 6 is a cross sectional view of an airbag near a slot of a height adjuster.

15 Fig. 7 shows a three-point safety restraint system.

Figs. 8 and 8a show various views of an inflated airbag.

Fig. 9 shows an alternative restraint system in relation to the C-pillar of a vehicle.

20 Fig. 10 is a cross sectional view of an alternate embodiment of the invention.

Fig. 11 shows an inflated airbag as it opens an associated cover.

25 Fig. 12 shows an inflated airbag in relation to the side of a vehicle.

Fig. 13 is a view of an inflated rear airbag.

Fig. 14 is an isometric view of an inflated rear airbag.

## DETAILED DESCRIPTION OF THE INVENTION

Fig. 1 illustrates the interior of a vehicle 20 and more particularly the construction of a typical side 22 of the vehicle. The vehicle is constructed using a frame 24. The frame defines an A-pillar 26, a B-pillar 28 and a C-pillar 30. A roof rail 32 connects the various pillars. The frame 24 includes a number of other structural elements (not shown) which are known in the art. Fig. 1 shows the location of the front window 34 and rear window 36, front armrest 38, rear armrest 40, front seat 42 and rear seat 44.

Vehicles typically include a three-point safety restraint system 50 (see Fig. 7) for each outboard seating location. These systems will typically include a seat belt retractor 59, a seat belt 64 configured into a shoulder belt portion 64a and lap belt portion 64b which is anchored at 69, a tongue 65 and a buckle 67. These systems 50 may also include belt-tightening devices (also referred to as pretensioners in the art) such as a buckle pretensioner 71 and retractor pretensioner (which is typically internal to the retractor). The purpose of these pretensioners or belt-tightening devices is to remove seat belt slack during the initial moments of a crash. Three-point safety restraint systems are typically used for each of the four outboard seating positions within the vehicle. As is known in the art, the shoulder belt portion 64a of the seat belt is positioned and guided by a web guide 60 (sometimes also known as a D-ring). For the driver and front seat passenger, the D-ring is typically located and secured to the B-pillar 28. A typical location of the web guide 60 for the front seat is shown by numeral 67

(in Figs. 1 and 2). The web guide 60a associated with the safety belt used for the rear passengers is secured to the C-pillar 30 (see Fig. 9). The front web guides 60, rather than being secured at a fixed  
5 location on the B-pillar may be part of a height adjusting mechanism (height adjuster) 66 which includes a slidable carriage 54 (to which a D-ring 60 is attached) permitting the occupant to adjust the vertical position of the web guide in a known manner.  
10 A similar configuration can be used for the rear web guide.

Fig. 2 illustrates the internal layout of the vehicle showing the B-pillar 28 and roof rail 32 and shows various elements of an occupant restraint  
15 system. An adjustable web guide mechanism 66 is shown attached to the B-pillar 28. The retractor 59 for front vehicle occupants, such as the driver, is typically attached to the floor or lower portion of the B-pillar and covered by a plastic molding 63. The  
20 shoulder belt portion 64 extends from a spool of the retractor and through a loop 68 of the D-ring 60 (which is shown in front of a housing 100). The D-ring also has a mounting opening 70 for a fastener. The D-ring 66 is secured to the slidable carrier 54 or  
25 alternatively fixedly positioned at a single location 67, such as shown in Fig. 1.

The housing 100 (of Fig. 2) also provides a decorative fascia to cover height adjuster 66 and B-pillar 28 . The housing includes a lower flange 102  
30 that fits within a mating opening of the top 104 of the trim 63. This flange 102 can be fixedly secured to the trim 63 in a known manner such as using interlocking tongues or grooves on each of the housing and trim 63. The upper portion 104 of the housing

includes fastener openings 106a, 106b which facilitate attachment of the housing to the roof rail 32

During assembly of the housing 100 to the B-pillar 28, the D-ring 60 (and the seat shoulder 64a, tongue 65 and anchor 69) are slipped through an opening 110 in the housing (from the rear of the housing to the front of the housing). Subsequently, the housing is attached to the B-pillar 28 and the D-ring 60, which was temporarily positioned in front of the housing, is secured to the movable carrier 54 or fixed mounting location 67. In this position the D-ring is in front of the housing with its fastener (which joins the D-ring to its mounting point) vertically movable in the slot 110. It should be appreciated that if the D-ring 60 were attached to a fixed point on the B-pillar a smaller (circular) opening would be used. In the above construction the housing 100 hides that portion of the shoulder belt 64a which extends to the retractor 59.

An alternate construction permits the shoulder belt 64a to lie in front of the housing 100. In this case the D-ring 60 can be secured to the carriage 54 without being first routed through opening 110.

Figs. 3 and 4 show the major components of the housing 100. The housing is generally C-shaped and includes a front or trim panel 150 and sidewalls 151a, b which matingly engage a back plate 152. The back plate includes four mounting lugs 154a-d which extend from the main portion 156 of the back plate 152. Each of the mounting lugs 154a-d is hollow having a bore 158. A respective fastener 254 extends through the holes 106a-d (of the plate 150) through each bore to secure the housing to the roof rail 32 and/or the B-pillar 28. The back plate 152 also

includes a plurality of inflator mounting holes 160 and an outwardly extending, hollow projection 162 having walls 164 defining an opening or channel 166 which extends through to the rear 168 of the back plate 152. When the housing 100, including the trim plate 150 and back plate 152, is mounted to the roof rail 32/B-pillar 28, the opening or channel 162 is positioned over the web guide mounting location 67 or height adjuster 66, with the opening 110 (of the trim panel 150) aligned to the opening 162 (in the back plate).

The trim plate 150 includes a tear seam 170 which extends above and below the opening 110.

The trim plate 150 and back plate 152 are designed such that when the two are mated together, they define an interior cavity 172 in which an airbag 200 and inflator 250 are located.

Figs. 5 and 6 illustrate a plan view and a sectional view of the airbag 200 prior to installation within the housing 100. The airbag 200 is constructed of two facing panels of material 202a and 202b which are secured together. Numeral 204 illustrates a peripheral line of stitches used to sew the panels of material together. In one embodiment the panels 202a,b are constructed of woven, nylon material. The material may be coated with silicone to reduce the permeability of the fabric to permit the airbag 200 to remain inflated for a predetermined length of time. If it is desired that the airbag maintain its inflated shape for an extended period of time the bag 200 will typically be coated with urethane instead of silicone and each of the sewn seams replaced by a heat seal. Alternatively the airbag 200 may be made of a thermoplastic such as urethane or thin film of similar

material. Each of the panels 202a and 202b includes an opening 206. A tubular section of material 210 is sewn to each of the panels proximate the openings 206 to provide a through passage 212 (which is open to atmosphere). The length of the tubular section is chosen to permit the two panels of material to separate sufficiently to provide depth to cushion the occupant's head from bottoming out and to completely cover the D-ring 60 when inflated. The tubular material 212 defines a wall of the airbag. With the two material panels 202a,b laid flat on each other, a portion of the tubular section is pulled through the opening 206 in the front panel 202a and formed into a roll 207 (see Fig. 3). As discussed below, the shoulder belt portion 64a of the seat belt 64 extends through this tubular section. Reference is again made to Fig. 5. A pair of parallel phantom lines has been superimposed upon the airbag 200 to illustrate the positional relationship of the opening 212 to the B-pillar 28/roof rail 32 and also to illustrate the positional relationship of the inflator to the opening 212 and to the B-pillar. The airbag 200 is generally rectangular or trapezoidal in shape, having a top and bottom 214a and 214b respectively and sides 216a and 216b. The airbag 200 further includes an upper and lower border of material 218a and 218b (which lie beyond the inflatable portion of the airbag). These borders include a plurality of mounting openings 220a-220d. The airbag 200 is preferably a dual-chambered airbag having an upper chamber 230a and a lower chamber 230b. A sewn seam or rectangular or oval separator panel 232 separates the two chambers of the airbag. The line 232 is segmented showing a plurality of air flow vents 232a which permit inflation gas to

flow between the two passages. As can be seen the inflator 250 is located in the lower chamber 230b. Upon deployment of the airbag 200, the lower chamber 230b is filled with inflation gas first and this gas is permitted to migrate into the upper chamber 230a through the vents 232a. Thus the lower chamber is generally at a higher pressure than that of the upper chamber. Once the lower chamber 230b is compressed by the occupant in a side impact or rollover crash, additional gas is controllably forced into the upper chamber at a faster rate to protect the occupant's head. Reference is again made to Fig. 3. The system further includes a metal retaining plate 240 which includes a plurality of mounting openings 242a-242c and a plurality of alignment openings 244a and 244b.

An inflator 250 is part of an inflator assembly 252 which also comprises a mounting bracket or housing 256. The mounting bracket or housing 256 includes a plurality of mounting studs 258a-258c which extend from the housing 256. The housing also includes a mechanism, such as a band 260. As can be seen, the inflator is positioned within or upon the bracket or housing 256 and secured thereto by means of the fastenable band 260. As can be seen in Fig. 3 the inflator 250 appears to be shown as being used outside of the airbag 200. This has been done for ease of illustration and is not the case. The inflator 250 is positioned within the airbag 200 as also shown in Fig. 13. Fig. 13 is a side view of a section of the airbag 200 showing the inflator studs 258a-c extending through corresponding holes 304a in the rear panel of the airbag 200. A small reinforcement panel 259 can be sewn to the rear panel 202b to reinforce the bag proximate the location of the inflator 250. This

panel 259 can be secured on the inside or outside of panel 202b. When located on the inside of the panel 202b the reinforcement panel 259 functions as a heat shield. The mounting studs 258a-c also extend  
5 through openings 310a in the reinforcement panel 259. The thickness of these panels has been exaggerated. The studs 258a-c are secured to the mounting plate 240 by nuts 300.

Fig. 14 is a partial plan view of the rear panel  
10 202b and illustrates the method by which the inflator 250 is placed within the airbag 200. A first C-shaped slit 302 is provided in the rear panel 202b. The slit defines a flap 304 which is shown folded back to uncover an opening 306 in the panel 202b. The  
15 reinforcement panel 259 similarly includes a second oppositely facing C-shaped slit 308 defining another panel 310, which is also shown partially folded back. The inflator 250 is placed inside the airbag 200 through opening 306. The flap 304 is manipulated so  
20 that its openings are placed about the mounting studs 258a-c. Thereafter the flap 310 is manipulated so its openings 310a are similarly received about the studs. In this configuration the opening 306 is effectively closed with the inflator 250 within the airbag 200.

25 The housing 100 is assembled as follows: the retainer plate 240 is positioned upon lugs 154c and d. When in position, the openings 242a-c are in alignment with the openings 160 of the back plate 152. The airbag 200, with the inflator 250 therein, is first  
30 folded to a generally rectangular configuration to fit within the channel 172 (see Fig. 3). With inflator 250 in place (within the airbag 200), the left side 224 of the airbag and edge 216a are folded or rolled inwardly toward the back plate 152. This folding or

rolling results in a folded or rolled edge 226 which is arranged to lie generally parallel to the wall segment 151a of the trim bracket 150. Similarly, the right-hand side 228 of the airbag is rolled or folded toward the mounting location of the inflator 250 into the configuration generally shown in Fig. 3.

Thereafter, the mounting studs 258a-c of the inflator are passed through the openings 242a-c to position the inflator 250 against the mounting plate 240 trapping an adjacent portion of the airbag 200 (and reinforcing panel 259) therebetween. This construction acts as a seal to prevent gas leakage from the bag about the inflator. The inflator 250 is secured to the back plate 152 by a plurality of fasteners 300. Further, the channel or opening 212 located within the airbag 200 is positioned about the sides 164 of the projection 162. With the airbag and inflator in place upon the back plate 152 the trim plate 150 is positioned thereon.

After the D-ring 60, tongue 65 and anchor bracket 69 (see Fig. 7) have been passed through the assembled housing 100, the housing 100 is secured to the B-pillar by fasteners 254 and positioned relative to the lower trim 63.

Upon the sensing of a side impact crash or rollover condition of the vehicle by an appropriate sensor or sensors located within the vehicle, an activation signal is communicated to the inflator 250 to inflate the airbag 200. As the airbag 200 inflates, it bears upon the inner surface of the trim panel 150 causing the trim panel to rupture along seam 170. The trim panel will divide into two halves or parts 150a and 150b, which pivot outwardly as the airbag 200 inflates. Upon deployment of the airbag,

the housing parts 150a and 150b will be trapped between the airbag 200 and the side of the vehicle away from the occupant.

5 Figs. 8 and 8a show views of the inflated airbag 200 adjacent the B-pillar 28. Fig. 8a also shows the shoulder belt 64a extending through the opening or channel 212 in the airbag. As the airbag inflates it lifts the shoulder belt portion 64a of the seat belt 64 upwardly and inwardly. This movement of the  
10 shoulder belt portion 64a creates a tension in the lap belt portion 64b (see Fig. 7) causing the lap belt portion 64b to slide within an aperture of the tongue 65 thereby eliminating slack in the seat belt about the vehicle occupant.

15 When deployed, as shown in Fig. 8, the airbag 200 extends forwardly from the B-pillar blocking a portion of the front window 34 preventing egress of the occupant.

Figs. 9 through 12 illustrate a similar  
20 system 80' applied to the rear seating positions of the vehicle. Fig. 9 illustrates the rear interior portion of the vehicle, and more particularly the rear window 36, roof rail 32 and C-pillar 30.

25 Additionally, Fig. 9 shows the general location of a rear seat belt retractor 59 having a length of seat belt 64 wound about a spool 59a of the retractor. The seat belt 64a extends through a D-ring 60a which is secured to the vehicle frame at a fixed point.

The system 80' includes a rear housing 100'  
30 having a trim plate 402 and a rear or back plate 404 defining a space or channel 406 therebetween. An inflator 250' and airbag 200' are positioned within the channel 406. The airbag is constructed to have a channel 212' therein (similar to channel 212 with

airbag 200) through which the seat belt 64a extends. The inflator 250' is mounted to the airbag 200' in the manner as described above. The housing 100 and particularly the trim panel 402, includes a tear seam  
5 407 (also shown in Fig. 9) which extends from a slot or opening 410.

With D-ring in place upon the C-pillar the belt 64 and anchor 69 are threaded through an opening 310 in a rear housing 100'. Subsequently, the assembled  
10 housing 100' is secured to the C-pillar.

Fig. 12 shows the airbag 200' in its deployed inflated state. As with the embodiment above, as the airbag 200' expands the trim panel 402 is opened along the tear seam 304. The resulting two halves 412a and  
15 412b of the front panel trim rotate outwardly (as the airbag inflates) toward the side of the vehicle. Upon inflation of the airbag, these housing sides or parts 412a and b are positioned between the airbag and the vehicle side.

## CLAIMS

1. A crash protection system (80) comprising:  
a web guide (60) attachable to a pillar of a  
5 vehicle;  
a seat belt system (50) having a shoulder  
belt portion (64a) supported by and extending from the  
web guide, the shoulder belt portion adapted to be  
secured about a seated occupant;  
10 an airbag assembly (100, 200, 250) including  
an airbag (200) initially stored in an uninflated or  
folded condition adjacent the web guide and when  
inflated is positioned adjacent the pillar (28, 30),  
the airbag including a first channel (212) for  
15 receiving a portion of the shoulder belt.
2. The crash protection system defined in Claim  
1 wherein the system further includes a housing (100)  
to protectively enclose the airbag, the housing  
20 adapted to be secured to the pillar, with the airbag  
folded therein.
3. The crash protection system defined in Claim  
2 wherein the housing includes a housing aperture  
25 (110, 407) adapted to be positioned in general in  
alignment with a first means (54, 67) for securing the  
web guide to the pillar, and a frangible portion (170,  
407) extending from the housing aperture which is  
opened by the inflating airbag to permit the airbag to  
30 extend beyond the housing to protect an occupant  
during the crash; the first channel, prior to  
inflation of the airbag, positioned generally about  
the housing aperture interior to the housing.

4. The crash protection system defined in Claim 3 wherein upon the tearing open of the frangible portion (170, 407), the housing divides into two parts (150a,b; 412a,b), each of which is positioned between the inflated airbag and an adjacent part of the vehicle.

5. The crash protection system defined in Claim 4 wherein when the housing, with the airbag installed therein, is mounted proximate the pillar, the shoulder belt portion (64a) extends through the first channel and through the housing opening.

6. The crash protection system defined in Claim 3 wherein the web guide is positioned upon the outside of the housing and a portion thereof extends through the housing opening and first channel and is secured to the pillar.

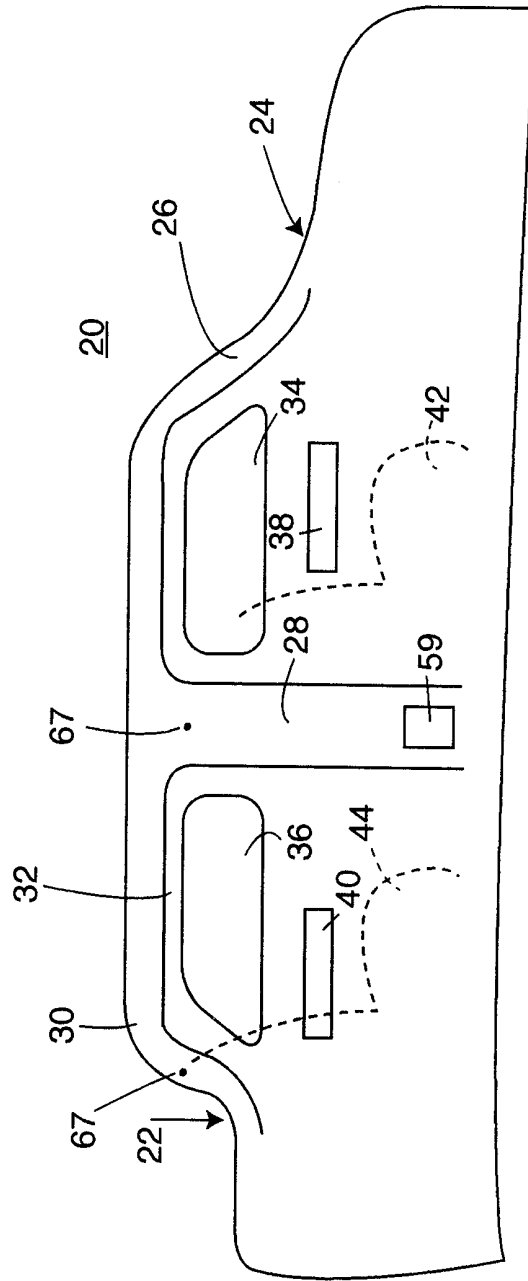
7. The crash protection system defined in Claim 6 wherein the shoulder belt portion includes a first part and a second part, the first part extends from a seat belt retractor, upwardly along the housing and is looped through the web guide; the second part extending from the web guide through a tongue to a first anchor point, the tongue lockable within a cooperating buckle forming a 3-point seat belt restraint, wherein a portion of the second part of the shoulder belt extending from the tongue forms a lap belt about the occupant;

wherein upon inflation of the airbag, the airbag raises the second part of the shoulder belt to reduce slack in the seat belt, about the occupant.

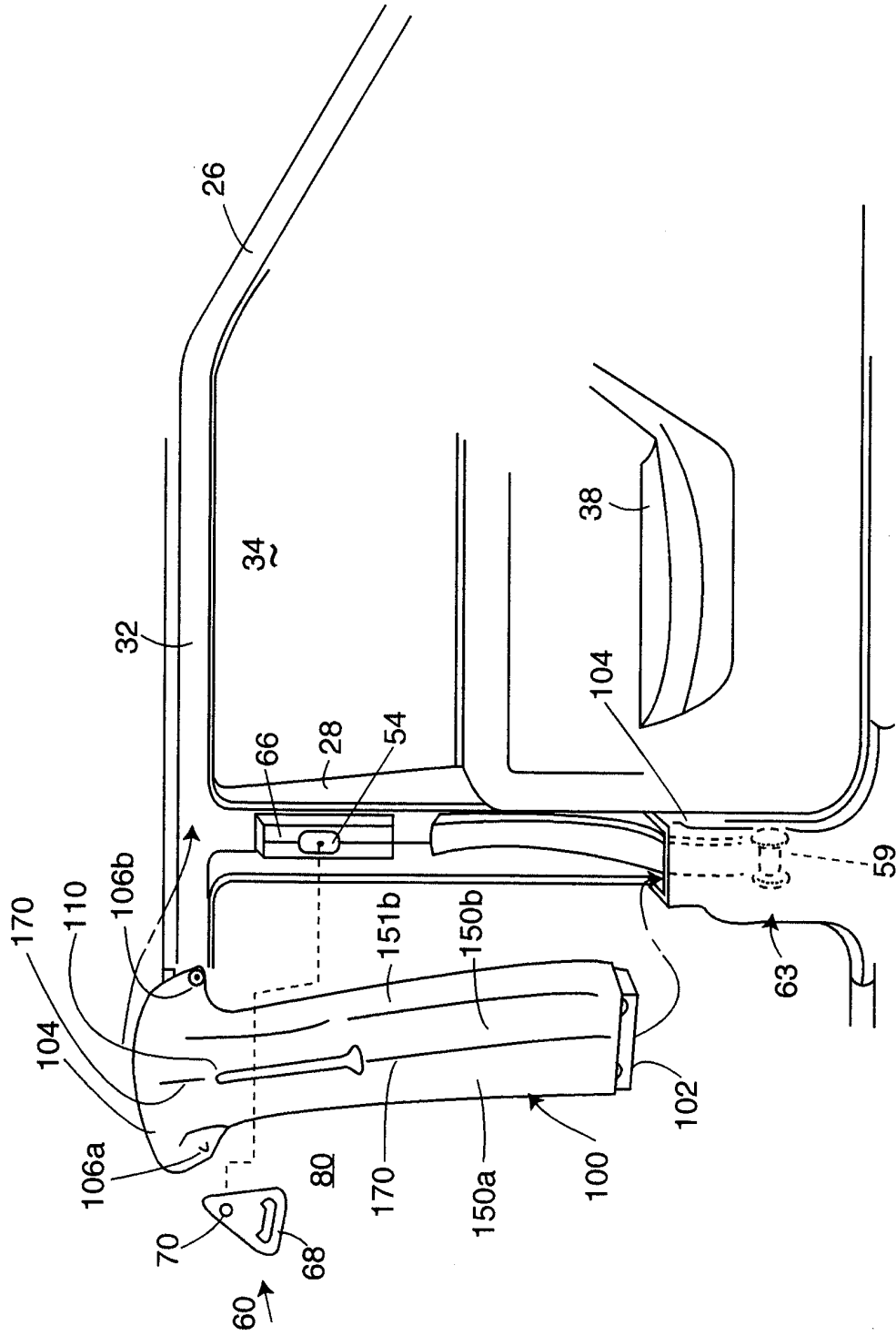
8. The crash protection system defined in Claim  
7 wherein the lap belt and second part of the shoulder  
belt are slidably received within a slot of the  
tongue, wherein upon inflation of the airbag and the  
5 lifting of the shoulder belt, the lap belt is drawn  
more tightly about the occupant.

9. The crash protection system defined in Claim  
1 wherein upon inflation of the airbag, a portion of  
10 the inflated airbag immediately below an extending  
portion of the shoulder belt lifts the shoulder belt  
upwardly relative to the seated occupant to aid in  
tightening the belt about the occupant.

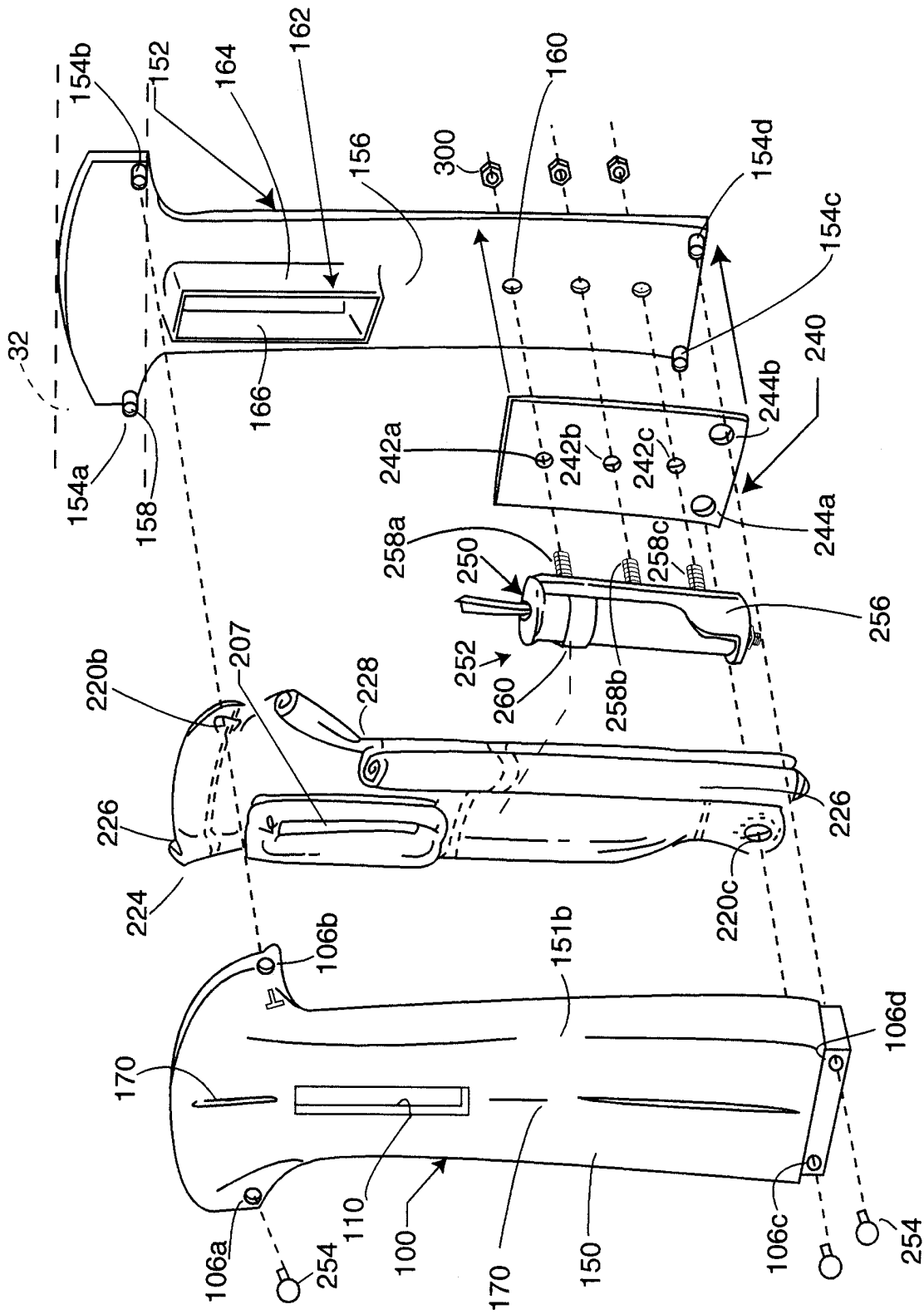
15 10. The crash protection system system defined  
in Claim 1 wherein the airbag comprises a plurality of  
panels joined together at a peripheral edge, each  
panel including an opening therein, a tube is joined  
to the panels at each opening defining the first  
20 channel.



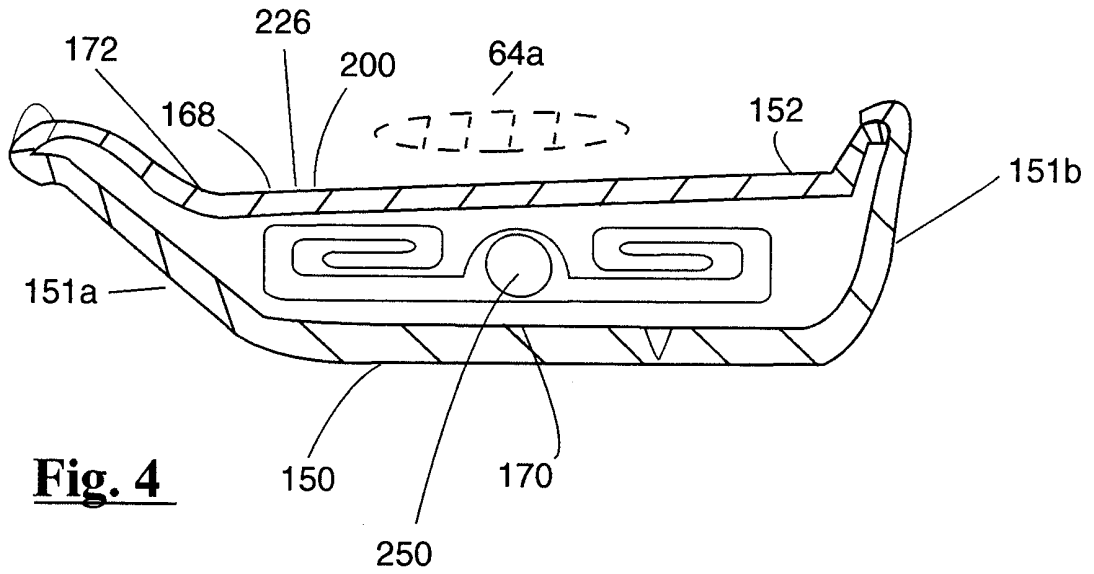
**Fig.1**



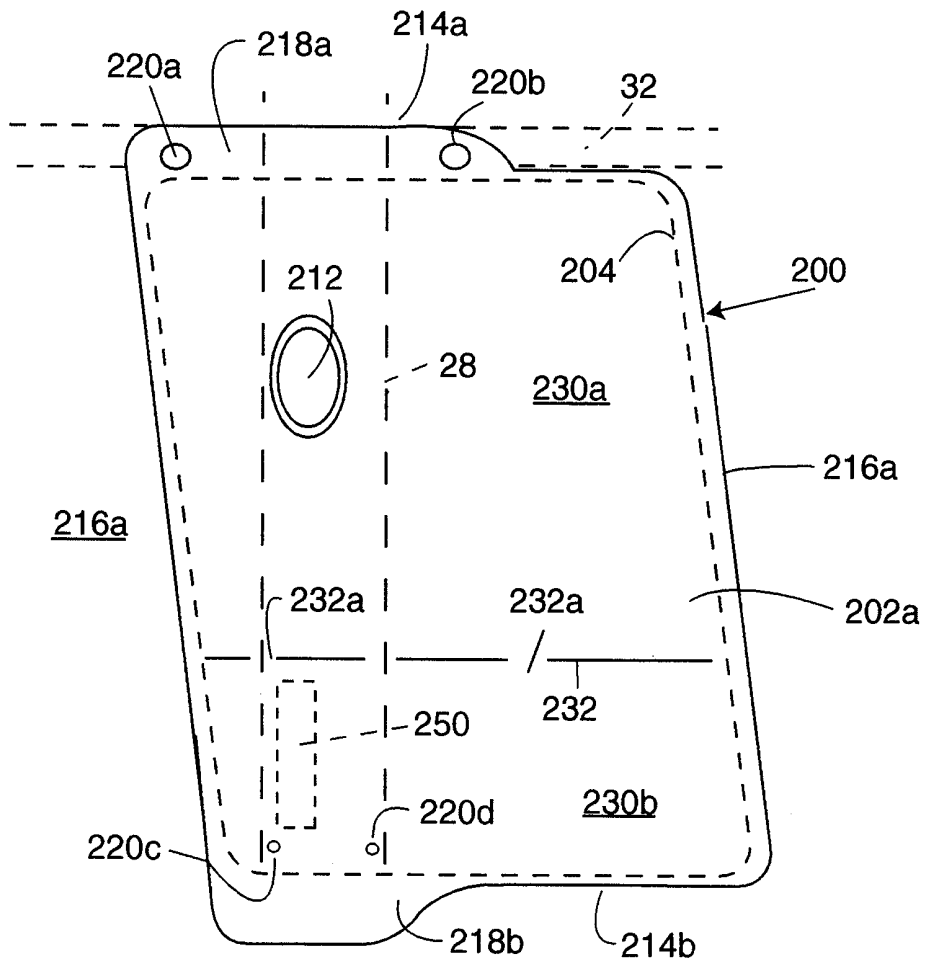
**Fig. 2**



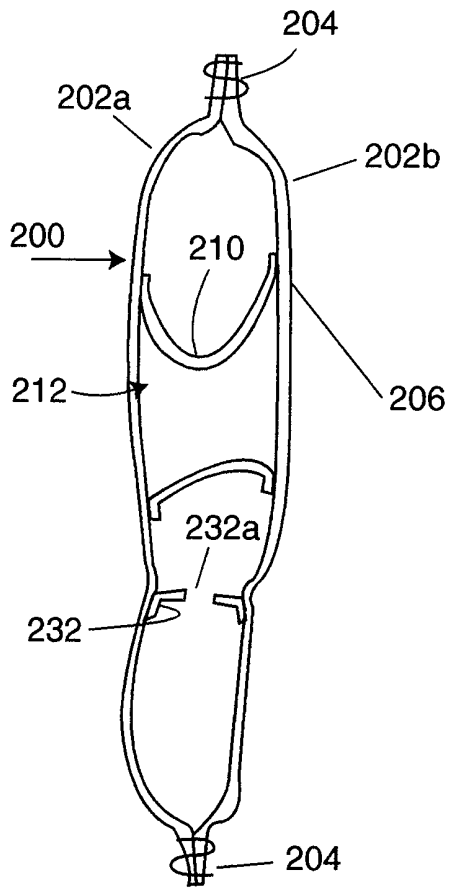
**Fig. 3**



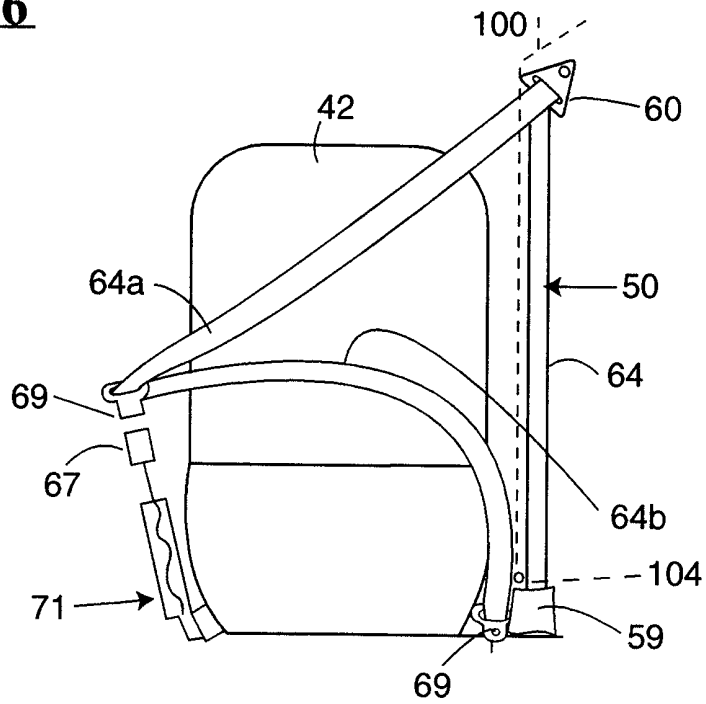
**Fig. 4**



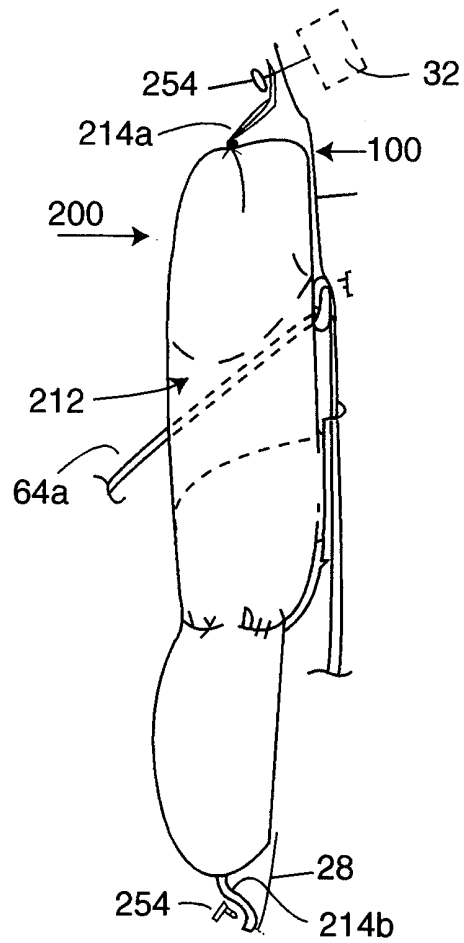
**Fig. 5**



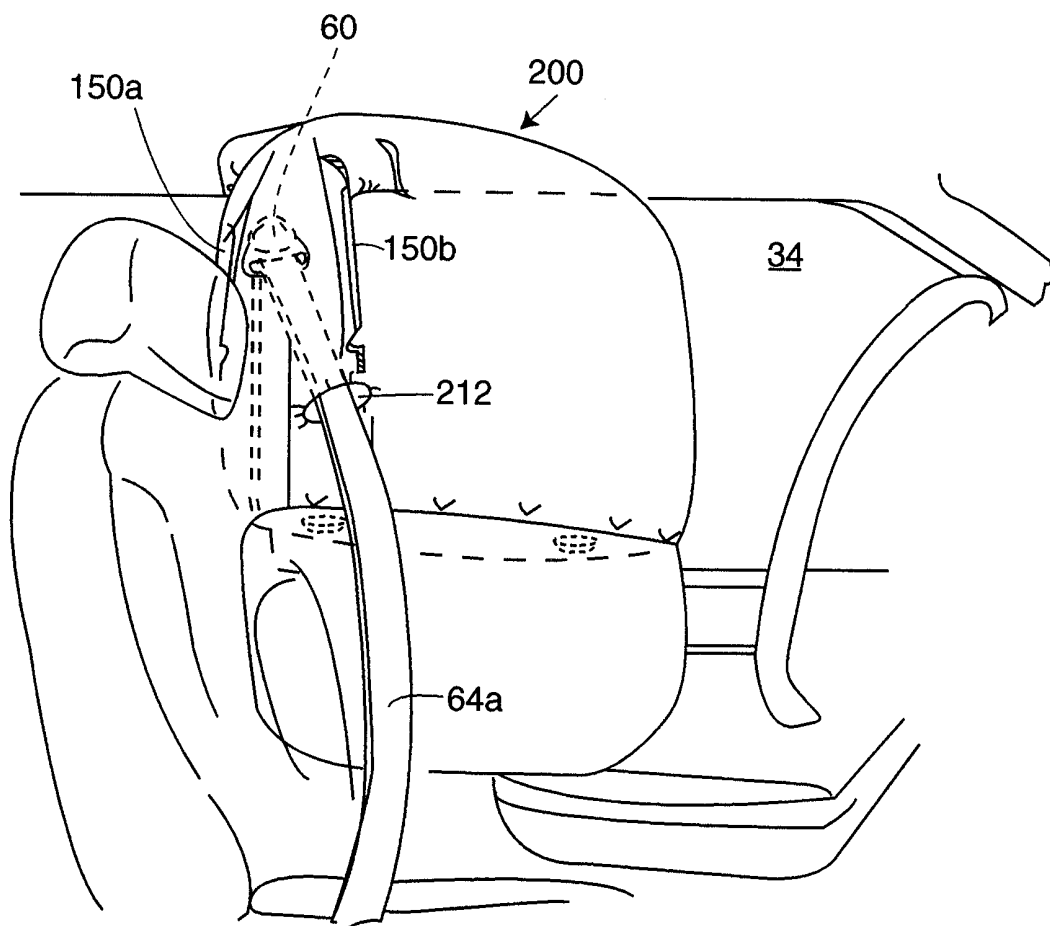
**Fig. 6**



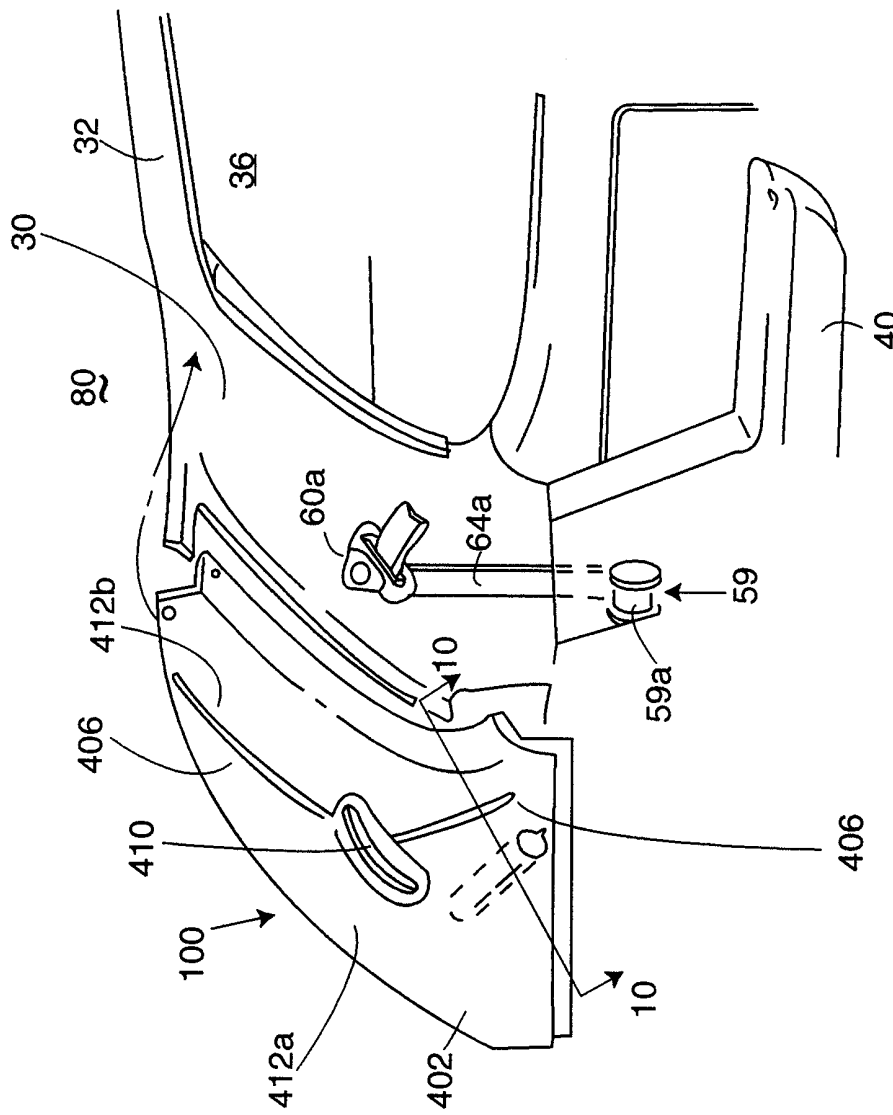
**Fig. 7**



**Fig. 8**

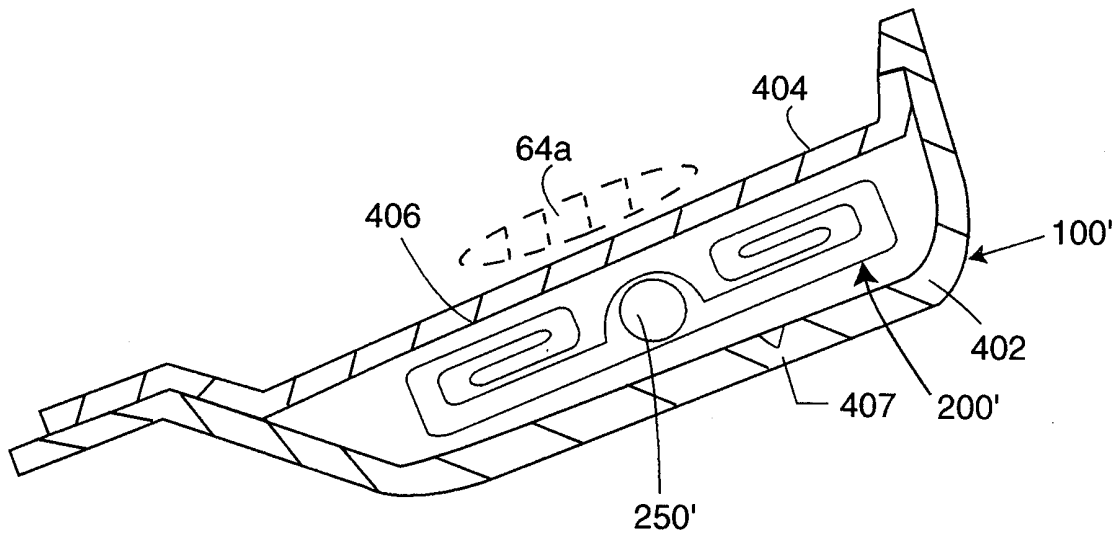


**Fig. 8a**

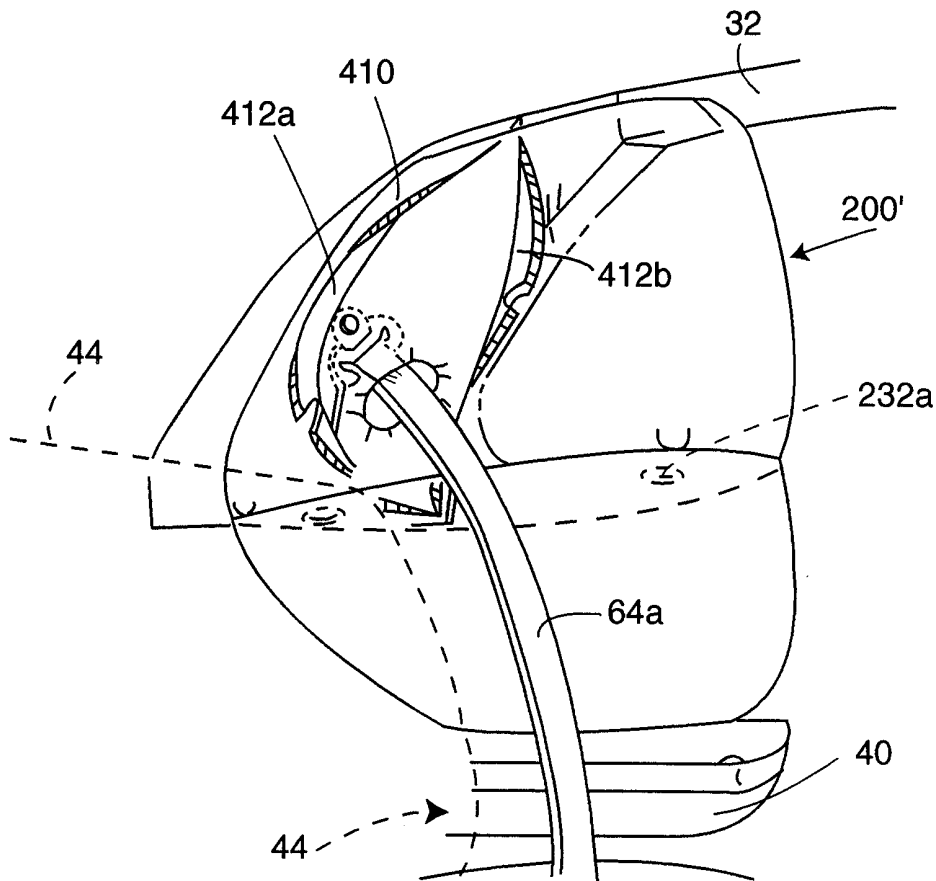


**Fig. 9**

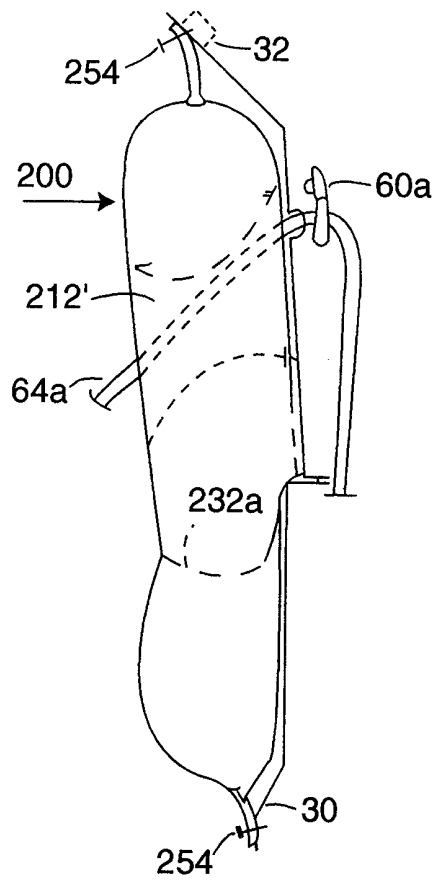
9/11



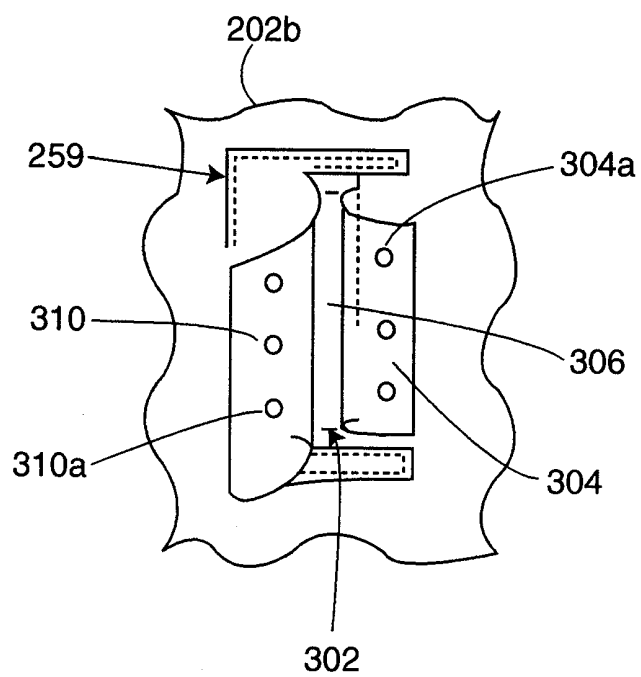
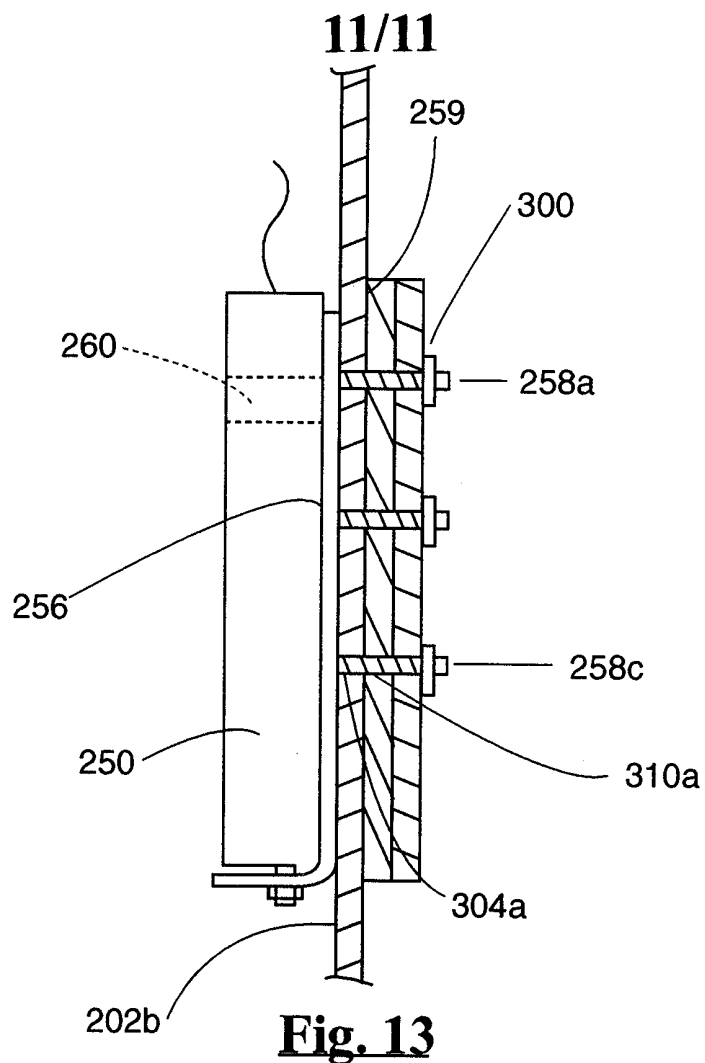
**Fig. 10**



**Fig. 11**



**Fig. 12**



## INTERNATIONAL SEARCH REPORT

International application No.  
PCT/US99/01257

## A. CLASSIFICATION OF SUBJECT MATTER

IPC(6) :B60R 21/18, 21/22  
US CL :280/730.2, 733, 743.1

According to International Patent Classification (IPC) or to both national classification and IPC

## B. FIELDS SEARCHED

Minimum documentation searched (classification system followed by classification symbols)

U.S. : 280/730.2, 733, 743.1, 730.1, 743.2, 729

Documentation searched other than minimum documentation to the extent that such documents are included in the fields searched

Electronic data base consulted during the international search (name of data base and, where practicable, search terms used)

## C. DOCUMENTS CONSIDERED TO BE RELEVANT

Category*	Citation of document, with indication, where appropriate, of the relevant passages	Relevant to claim No.
X ----- Y	JP 5-139232 A (SHUICHI et al.) 08 JUNE 1993 (08.06.93), Figures 4 and 5, abstract.	1 ----- 2
Y	JP 5-38993 A (MITSUYOSHI et al.) 19 FEBRUARY 1993 (19.02.93), Figures 1-6.	2
A	JP 3-276844 A (KAZUHIRO et al.) 09 DECEMBER 1991 (09.12.91).	1
A	US 5,161,821 A (CURTIS) 10 NOVEMBER 1992 (10.11.92).	1
A	US 5,586,782 A (ZIMMERMAN, II et al.) 24 DECEMBER 1996 (24.12.96).	1
A, E	US 5,871,230 A (LEWIS) 16 FEBRUARY 1999 (16.02.99).	1

 Further documents are listed in the continuation of Box C.
  See patent family annex.

* Special categories of cited documents:	"T" later document published after the international filing date or priority date and not in conflict with the application but cited to understand the principle or theory underlying the invention
"A" document defining the general state of the art which is not considered to be of particular relevance	"X" document of particular relevance; the claimed invention cannot be considered novel or cannot be considered to involve an inventive step when the document is taken alone
"E" earlier document published on or after the international filing date	"Y" document of particular relevance; the claimed invention cannot be considered to involve an inventive step when the document is combined with one or more other such documents, such combination being obvious to a person skilled in the art
"L" document which may throw doubts on priority claim(s) or which is cited to establish the publication date of another citation or other special reason (as specified)	"&" document member of the same patent family
"O" document referring to an oral disclosure, use, exhibition or other means	
"P" document published prior to the international filing date but later than the priority date claimed	

Date of the actual completion of the international search

22 MARCH 1999

Date of mailing of the international search report

05 APR 1999

Name and mailing address of the ISA/US  
Commissioner of Patents and Trademarks  
Box PCT  
Washington, D.C. 20231

Facsimile No. (703) 305-3230

Authorized officer

PETER ENGLISH

*Diane Smith jr*

Telephone No. (703) 308-1113