



(86) Date de dépôt PCT/PCT Filing Date: 2005/06/24
 (87) Date publication PCT/PCT Publication Date: 2007/01/04
 (85) Entrée phase nationale/National Entry: 2007/12/18
 (86) N° demande PCT/PCT Application No.: RU 2005/000350
 (87) N° publication PCT/PCT Publication No.: 2007/001202

(51) Cl.Int./Int.Cl. *H01G 9/155* (2006.01)
 (71) Demandeur/Applicant:
 UNIVERSAL SUPERCAPACITORS LLC, US
 (72) Inventeurs/Inventors:
 NEDOSHIVIN, VALERY PAVLOVICH, RU;
 STEPANOV, ALEXEY BORISOVICH, RU;
 TARASOV, SERGEY VLADIMIROVICH, RU;
 VARAKIN, IGOR NIKOLAEVICH, RU;
 RAZUMOV, SERGEY NIKOLAEVICH, RU
 (74) Agent: GASTLE AND ASSOCIATES

(54) Titre : ELECTRODE ET COLLECTEUR DE COURANT POUR CONDENSATEUR ELECTROCHIMIQUE AYANT UNE DOUBLE COUCHE ELECTRIQUE ET CONDENSATEUR ELECTROCHIMIQUE AYANT UNE DOUBLE COUCHE ELECTRIQUE FORMEE A L'AIDE DE CEUX-CI

(54) Title: ELECTRODE AND CURRENT COLLECTOR FOR ELECTROCHEMICAL CAPACITOR HAVING DOUBLE ELECTRIC LAYER AND DOUBLE ELECTRIC LAYER ELECTROCHEMICAL CAPACITOR FORMED THEREWITH

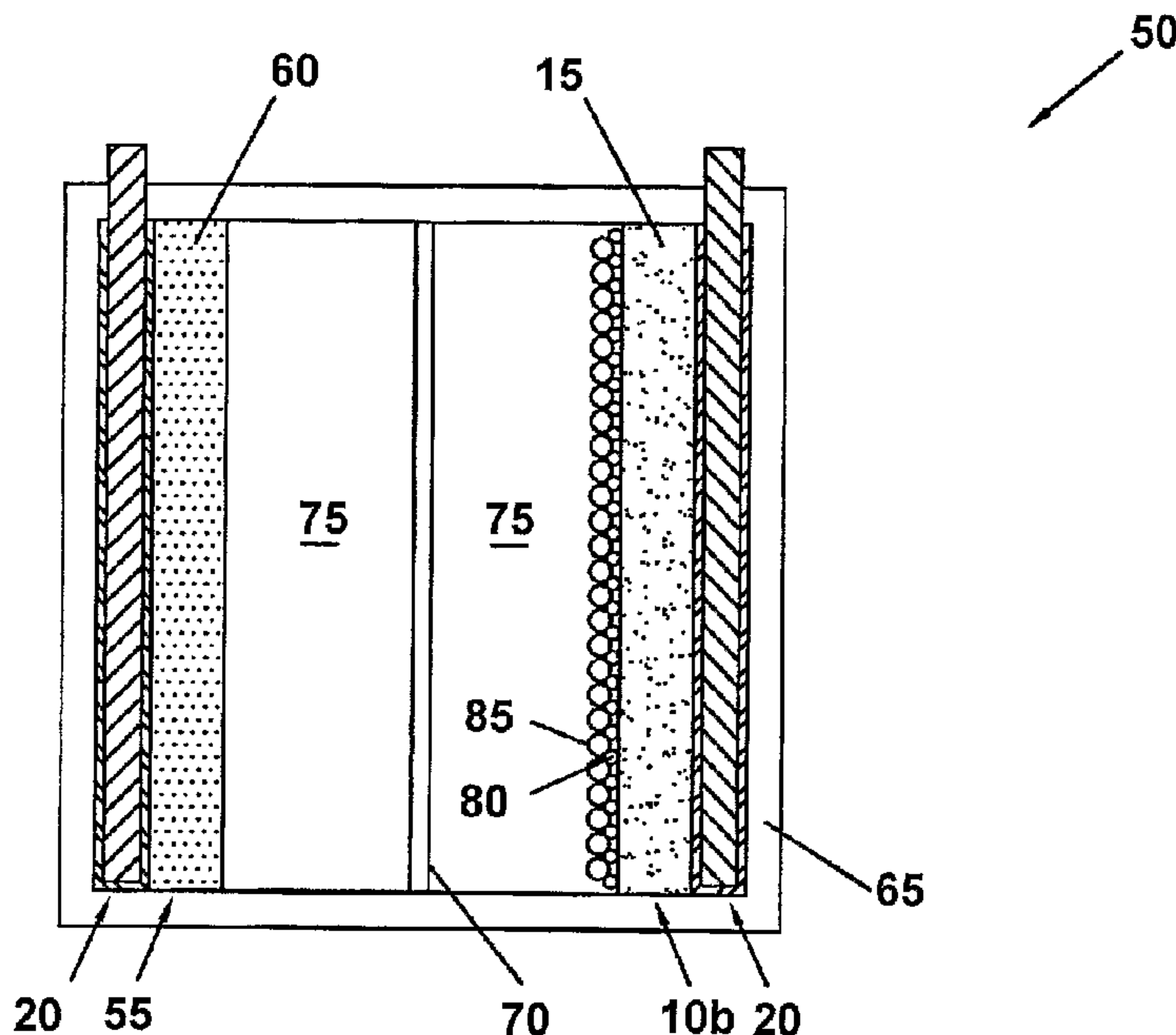

(57) **Abrégé/Abstract:**

An electrode and a DEL capacitor formed therewith. The electrode will typically be a polarizable electrode comprised of an activated carbon material having a substantially zero ash percentage and a low percentage of transition metals. In constructing a DEL capacitor employing the electrode of the present invention, a non-polarizable electrode consisting of a lead dioxide/lead sulfate compound is preferably also used. The DEL capacitor may utilize an acid-based electrolyte, such as an aqueous sulfuric acid electrolyte. Consequently, the present invention also includes a current collector that preferably comprises a base material consisting of lead or a lead compound and a protective coating material that is resistant to an acid-based electrolyte. Preferably, the protective coating material is formed from a polymer base and a conductive dope that may thereafter be applied to the current collector base material by a variety of methods.

(12) INTERNATIONAL APPLICATION PUBLISHED UNDER THE PATENT COOPERATION TREATY (PCT)

(19) World Intellectual Property Organization
International Bureau(43) International Publication Date
4 January 2007 (04.01.2007)

PCT

(10) International Publication Number
WO 2007/001202 A1(51) International Patent Classification:
H01G 9/155 (2006.01)(21) International Application Number:
PCT/RU2005/000350

(22) International Filing Date: 24 June 2005 (24.06.2005)

(25) Filing Language: English

(26) Publication Language: English

(71) Applicant (for all designated States except US): UNIVERSAL SUPERCAPACITORS LLC [US/US]; 1 Riverside Plaza, Columbus, OH 43215-2373 (US).

(72) Inventors; and

(75) Inventors/Applicants (for US only): NEDOSHIVIN, Valery Pavlovich [RU/RU]; Apartment 29, 3 VNIIPP settlement, Solnechnogorsky District, Moscow Region, 141552 (RU). STEPANOV, Alexey Borisovich [RU/RU]; Apartment 119, 6 Syrenevy Boulevard, Troitsk, Moscow Region, 142190 (RU). TARASOV, Sergey Vladimirovich [RU/RU]; Apartment 7, 7D Ust-Kurdumskaya Street, Saratov, 410018 (RU). VARAKIN, Igor Nikolaevich [RU/RU]; Apartment 80, 13 Syrenevy Boulevard, Troitsk, Moscow Region, 142190 (RU). RAZUMOV, Sergey Nikolaevich [RU/RU]; Apartment 7, Building 4, 8 Electrichesty Lane, Moscow, 123056 (RU).

(74) Agent: LAW FIRM "GORODISSKY & PARTNERS" LIMITED; Galina Borisovna EGOROVA, Alexander Vladimirovich MITS et al., B. Spasskaya str., 25, stroenie 3, Moscow, 129010 (RU).

[Continued on next page]

(54) Title: ELECTRODE AND CURRENT COLLECTOR FOR ELECTROCHEMICAL CAPACITOR HAVING DOUBLE ELECTRIC LAYER AND DOUBLE ELECTRIC LAYER ELECTROCHEMICAL CAPACITOR FORMED THEREWITH

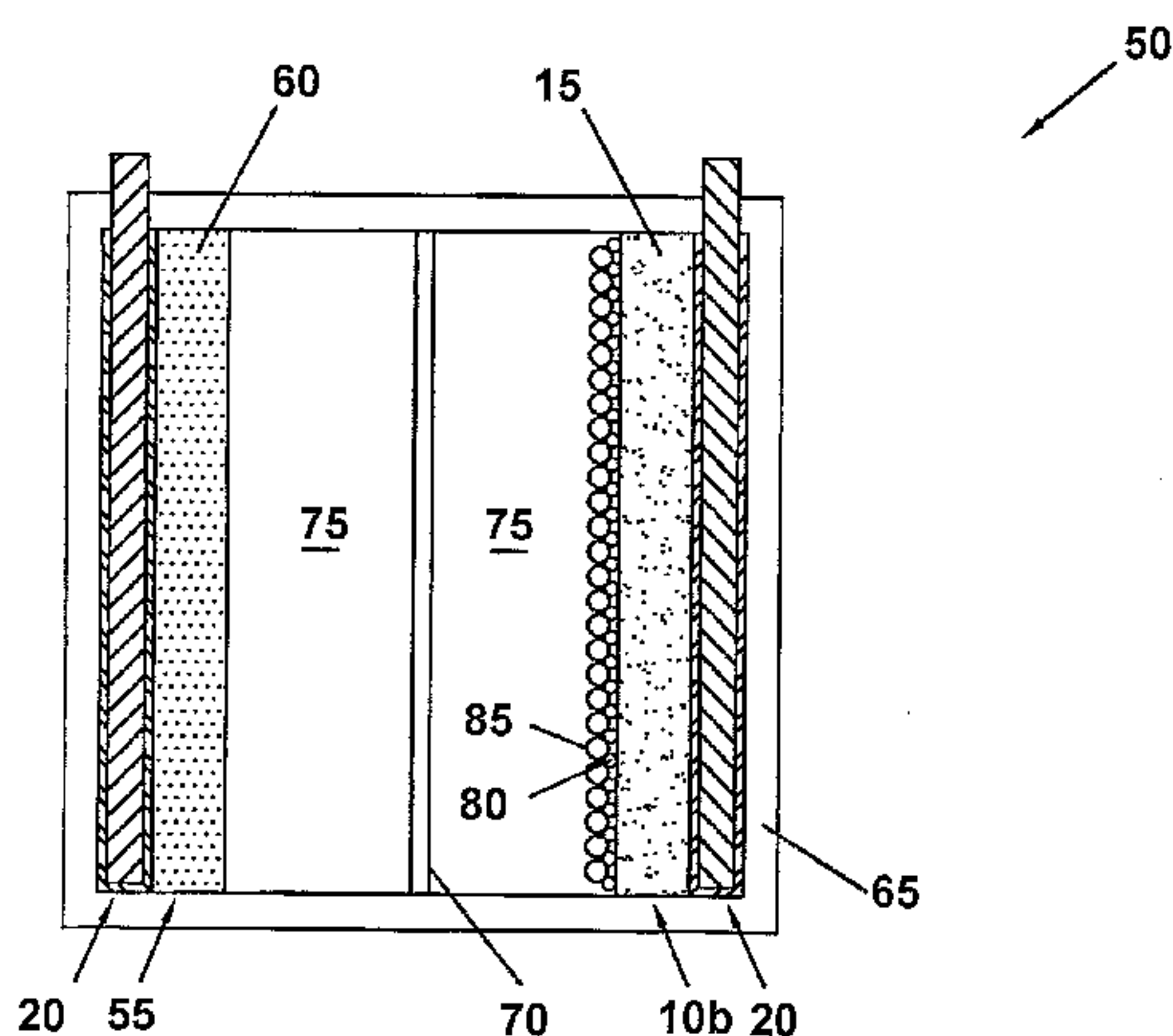

(57) Abstract: An electrode and a DEL capacitor formed therewith. The electrode will typically be a polarizable electrode comprised of an activated carbon material having a substantially zero ash percentage and a low percentage of transition metals. In constructing a DEL capacitor employing the electrode of the present invention, a non-polarizable electrode consisting of a lead dioxide/lead sulfate compound is preferably also used. The DEL capacitor may utilize an acid-based electrolyte, such as an aqueous sulfuric acid electrolyte. Consequently, the present invention also includes a current collector that preferably comprises a base material consisting of lead or a lead compound and a protective coating material that is resistant to an acid-based electrolyte. Preferably, the protective coating material is formed from a polymer base and a conductive dope that may thereafter be applied to the current collector base material by a variety of methods.

WO 2007/001202 A1

WO 2007/001202 A1



(81) **Designated States** (*unless otherwise indicated, for every kind of national protection available*): AE, AG, AL, AM, AT, AU, AZ, BA, BB, BG, BR, BW, BY, BZ, CA, CH, CN, CO, CR, CU, CZ, DE, DK, DM, DZ, EC, EE, EG, ES, FI, GB, GD, GE, GH, GM, HR, HU, ID, IL, IN, IS, JP, KE, KG, KM, KP, KR, KZ, LC, LK, LR, LS, LT, LU, LV, MA, MD, MG, MK, MN, MW, MX, MZ, NA, NG, NI, NO, NZ, OM, PG, PH, PL, PT, RO, RU, SC, SD, SE, SG, SK, SL, SM, SY, TJ, TM, TN, TR, TT, TZ, UA, UG, US, UZ, VC, VN, YU, ZA, ZM, ZW.

(84) **Designated States** (*unless otherwise indicated, for every kind of regional protection available*): ARIPO (BW, GH, GM, KE, LS, MW, MZ, NA, SD, SL, SZ, TZ, UG, ZM,

ZW), Eurasian (AM, AZ, BY, KG, KZ, MD, RU, TJ, TM), European (AT, BE, BG, CH, CY, CZ, DE, DK, EE, ES, FI, FR, GB, GR, HU, IE, IS, IT, LT, LU, MC, NL, PL, PT, RO, SE, SI, SK, TR), OAPI (BF, BJ, CF, CG, CI, CM, GA, GN, GQ, GW, ML, MR, NE, SN, TD, TG).

Published:

- with international search report
- with amended claims

For two-letter codes and other abbreviations, refer to the "Guidance Notes on Codes and Abbreviations" appearing at the beginning of each regular issue of the PCT Gazette.

**ELECTRODE AND CURRENT COLLECTOR FOR ELECTROCHEMICAL
CAPACITOR HAVING DOUBLE ELECTRIC LAYER AND DOUBLE
ELECTRIC LAYER ELECTROCHEMICAL CAPACITOR FORMED
THEREWITH**

5

BACKGROUND OF THE INVENTION

The present invention relates to an electrode for use in an electrochemical capacitor. More particularly, the electrode of the present invention is ideal for use in an electrochemical capacitor of high energy storage capacity, wherein the capacitor has a double electric layer. Such capacitors are often referred to as "ultracapacitors" or "supercapacitors," however, they will simply be referred to herein as "capacitors."

There is an increasing focus on the use of capacitors as a means for storing electrical energy. These capacitors can efficiently store and redistribute a large amount of electrical energy. For purposes of illustration, and not limitation, such capacitors may be used: as a main power supply at a particular location; as a back-up power supply at a particular location; for power quality assurance (i.e., to compensate for short-term power "surges", "spikes", and "skips" common to a utility-supplied source of electrical power); to provide load-leveling by storing an amount of electrical energy provided during off-peak hours and thereafter re-distributing said electrical energy during periods of peak demand; and as a primary or secondary power source for a variety of vehicles.

A double electric layer (DEL) capacitor typically comprises a pair of electrodes residing in a spaced apart relationship, between which is an electrolyte. The electrolyte can be either aqueous or non-aqueous in nature, depending on the composition of the electrodes. A separator typically also resides in the space between the electrodes. One or both of the electrodes may store electrical energy through a double layer electrochemical mechanism. In a double electric layer storage process, a layer of electrons forms at the electrode side of the electrode/electrolyte interface. A layer of positive ions also forms on the electrolyte side of the electrode/electrolyte interface. The voltage across the electrode/electrolyte interface increases with charge accumulation, and is eventually released during discharge of the capacitor.

One or both of the electrodes of a DEL capacitor may generally be polarizable electrodes. The polarizable electrode may comprise, for example, an active material and a current collector to which the active material is affixed. The most commonly

employed active material is likely one of a plurality of activated carbon materials. Activated carbon materials are inexpensive and have a high specific surface area per unit mass. Electrodes are typically formed from activated carbon materials in the form of an activated carbon powder and a binder, or from woven or non-woven activated carbon fiber materials. However, preparation of DEL electrodes from an activated carbon powder is often preferable due to its lower cost.

As stated above, in a typical capacitor, one or both of the electrodes may be polarizable. However, it has been found that constructing a DEL capacitor with one polarizable electrode and one non-polarizable electrode provides the DEL capacitor with a specific energy capacity that is greater than that of a capacitor with two polarizable electrodes. In such a DEL capacitor, charge storage at the non-polarizable electrode occurs as a result of oxidation and reduction reactions at the interface of the non-polarizable electrode and the electrolyte. Such an electrode is commonly said to exhibit Faradaic pseudocapacitive behavior.

Each of the electrodes of such a DEL capacitor is typically affixed by some means to a current collector. Current collectors are commonly constructed of a material that exhibits electrical conductivity - typically a metal. As at least a portion of the current collector, along with the electrode material, must reside in the electrolyte, it must be ensured that the current collector material will not react adversely thereto. For example, the electrolyte of a DEL capacitor may consist of an aqueous sulfuric acid. In such a case, certain precautions such as, for example, coating or otherwise protecting the portion of the current collector exposed to the electrolyte must generally be undertaken, as the sulfuric acid electrolyte may corrode or erode the current collector material.

While various embodiments of DEL capacitors are currently known, each typically has one or more inherent disadvantages. For example, the activated carbon powders used to form the electrodes of common DEL capacitors are often derived from the processing of coal raw material. Such an activated carbon powder will generally exhibit a high ash percentage (e.g., 15 weight percent or more). Additionally, these activated carbon powders also typically contain an unacceptably high quantity of admixtures of transition metals. This high ash percentage and large quantity of admixtures of transition metals present in the activated carbon powder will, of course,

eventually become a part of any electrode formed therefrom. The presence of these impurities in an electrode limits the voltage to which a DEL capacitor employing the electrode can be charged. For example, the presence of admixtures of transition metals can reduce the decomposition voltage of an acid electrolyte and, thereby, decrease the operating voltage of a capacitor.

There are also other disadvantages to known DEL capacitor designs. For example, many of the activated carbon materials employed to form the electrodes of such capacitors require the addition of a large quantity of binder material. The use of more binder material results in a corresponding reduction in the amount of activated carbon material present in the resultant electrode. A reduction in the amount of activated carbon present in the electrode, subsequently diminishes the capacitance and electrical energy storage capabilities of a capacitor to which the electrode is installed. Additionally, steel and similar metals are often used to form the current collectors of a DEL capacitor. Unfortunately, steel and many other metals are not resistant to an acid electrolyte. For example, in the presence of a sulfuric acid electrolyte, a steel current collector will degrade, such as by corrosion. Corrosion of the current collectors can have a negative effect on the cycling capacity and service life of a capacitor. Consequently, to reduce or avoid degradation of such current collectors, known DEL capacitor designs have employed a protective coating that is resistant to the electrolyte used in the capacitor. The protective coating, depending on its composition, can be applied to the current collector by a variety of methods. As one example, a steel current collector may utilize a protective layer of graphite foil. While certain of these coating materials may offer acceptable resistance to the electrolyte in which they reside, there has been a great deal of difficulty in obtaining adequate adhesion between the protective coatings and the subjacent electrode materials. As a result, the electrolyte will often eventually intrude between the protective coating and the current collector. It should be realized that any degradation or erosion of such a metal current collector can adversely affect performance of a DEL capacitor. For example, when a sulfuric acid electrolyte is used, even substantially insignificant quantities of iron present therein can harshly decrease the decomposition voltage of the electrolyte and result in a significant reduction in the operating voltage of the capacitor. Hence, the degradation of the current collector should be avoided.

As can be understood from the foregoing discussion, there are several disadvantages associated with known DEL capacitor designs. The electrode of the present invention utilizes an improved design that substantially reduces or eliminates many of the problems associated with known DEL capacitors. The design of the electrode of the present invention can be used to produce a DEL capacitor having an increased specific energy, better reliability, greater cycling capacity, and an increased service life.

SUMMARY OF THE INVENTION

The present invention includes a novel electrode and a DEL capacitor formed therewith. The electrode of the present invention is contemplated to be a polarizable electrode. The composition of the electrode preferably includes an activated carbon material that has an ash percentage of substantially zero, and that is also substantially free of admixtures of transition metals. Such activated carbon materials are typically obtained from a synthetic base material, such as, for example, by the carbonization and subsequent activation of a furane tar or resin. Other activated carbon materials may also be acceptably used, however, as will be described in more detail below. Preferably, a fluorine-containing binder such as polytetrafluoroethylene (PTFE), or a similar polymer substance, is added to the activated carbon material during production of the electrode material. In constructing a DEL capacitor employing the electrode of the present invention, a non-polarizable electrode is also preferably utilized. In one embodiment of such a DEL capacitor, a non-polarizable electrode composed of lead dioxide/lead sulfate compound is preferably employed.

The present invention further contemplates a DEL capacitor employing an electrode of the present invention. It is expected that such a DEL capacitor may utilize an acid-based electrolyte, such as an aqueous sulfuric acid electrolyte. Consequently, the present invention also includes a current collector for use with the above-described electrode. The current collector of the present invention preferably consists essentially of a base material that will provide for the desired operating voltage window. A number of metallic and non-metallic materials may be successfully employed for this purpose. However, based on its ability to meet various physical requirements while simultaneously being low in cost, lead or a lead compound is especially appealing as a current collector base material. The base material is preferably coated with a protective

material that is resistant to an acid-based electrolyte. Preferably, the protective coating material is formed from a polymer base and a conductive dope that may thereafter be applied to the current collector base material by a variety of methods. When such a current collector is manufactured using lead or a lead compound as a base material, the
5 current collector is less expensive and more stable in an acid-based electrolyte than a steel current collector. Further, the protective coating contemplated by the present invention is more reliable than known protective coatings, such as foil coatings that are commonly attached to the current collector base material via an adhesive.

Thus, the electrode of the present invention allows a DEL capacitor formed
10 therewith to overcome many of the disadvantages of known DEL capacitors. Additional details of the electrode and DEL capacitor of the present invention will become apparent upon a reading of the following description and reference to the accompanying drawings.

BRIEF DESCRIPTION OF THE DRAWINGS

15 In addition to the features mentioned above, other aspects of the present invention will be readily apparent from the following descriptions of the drawings and exemplary embodiments, wherein like reference numerals across the several views refer to identical or equivalent features, and wherein:

Figure 1a illustrates a front elevational view of one embodiment of a polarizable
20 electrode assembly of the present invention;

Figure 1b is a right side, cross-sectional view of the polarizable electrode assembly of Figure 1a;

Figure 2a is a front elevational view of a polarizable electrode portion of the polarizable electrode assembly of Figures 1a-1b;

25 Figure 2b is a right side view of the polarizable electrode of Figure 2a;

Figure 3a is a current collector portion of the polarizable electrode assembly of Figures 1a-1b;

Figure 3b is a is a right side, cross-sectional view of the current collector of Figure 3a;

30 Figure 4 depicts one embodiment of a DEL capacitor of the present invention;
and

Figure 5 shows an alternate embodiment of a DEL capacitor of the present

invention, wherein a plurality of the polarizable electrode assemblies of Figures 1a-1b are employed.

DETAILED DESCRIPTION OF THE EXEMPLARY EMBODIMENT(S)

A detailed view of one embodiment of a polarizable electrode assembly **10** of the present invention can be seen by reference to Figure 1. The polarizable electrode assembly **10** is formed by sandwiching a current collector **20** having a protective coating **30** between two polarizable electrodes **15**. The polarizable electrodes **15** and the current collector **20** can be individually observed in Figures 2-3, respectively. It should be noted that certain dimensions, particularly the thickness of the various components of the electrode assembly **10**, have been exaggerated in Figures 1-5 for purposes of clarity. While it may be possible for an electrode assembly **10** of the present invention to exhibit such a dimensional relationship, it is not intended that an electrode assembly of the present invention be limited to what is shown in Figure 1-5.

The material used to form the polarizable electrodes **15** shown in Figures 1-2 and 4-5 is an activated carbon material having a very low, or substantially zero, ash percentage. The activated carbon material is preferably also substantially free of admixtures of transition metals. More specifically, it is preferred that the concentration of transition metals in the activated carbon material be less than 500 ppm. Activated carbons produced from various synthetic materials, from carbon black, and from vegetable and mineral materials may be successfully used. Such materials may be subjected to special purification in order to reduce the concentration of transition metals to an acceptable level. An activated carbon material obtained by the proper carbonization and subsequent activation of a furane tar or resin has been determined to be particularly well suited for use in forming a polarizable electrode of the present invention. An acceptable form of such an activated carbon material is available in Russia under the commercial name "FAS." Such an activated carbon material may be in sheet, disk, granule, powder, or other form. Preferably, however, the polarizable electrodes **15** are manufactured using a powdered form of this type of activated carbon material. More preferably, the diameter of the activated carbon particles is no greater than 100 μm , and may be as small as about 100 \AA .

To the activated carbon powder material is added a binder. While a number of different binder materials may be used with acceptable results, in one exemplary

embodiment of a polarizable electrode of the present invention, the binder includes a fluorine-containing compound, more specifically, a fluorinated polyolefin. One particular binder material that has been found to produce good results is polytetrafluoroethylene (PTFE). In the particular embodiment of the polarizable electrode **15**, a binder comprising a fluoroplastic emulsion was mixed with the activated carbon powder. An acceptable version of such a fluorelastic emulsion is available under the commercial name of "F-4D" in Russia. The F-4D fluoroplastic emulsion is an aqueous suspension of fluoroplastic (Teflon) powder. The amount of binder added to the activated carbon material may vary depending on the exact activated carbon material employed. Preferably, however, about 0.5-5.0 weight percent of binder material is used. For example, in forming the particular polarizable electrode **15** shown in Figures 1-2 and 4-5, approximately 1.0 weight percent of the fluoroplastic emulsion was mixed into the activated carbon powder.

A polarizable electrode **15** of the present invention can be formed by a variety of known techniques, depending on the desired size and shape thereof. For purposes of illustration, polarizable electrodes of the present invention may be molded, extruded, pressed or rolled into the desired size and/or shape. As one specific example, the polarizable electrodes **15** employed in the exemplary polarizable electrode assembly **10** of Figures 1 and 4 were formed by first mixing the activated carbon powder with the fluorine-containing binder material, and subsequently drying the resulting compound to form bricks. The bricks were later wetted with ethyl alcohol and rolled into strips of desired thickness. Electrode cards, or plates, of predetermined length and width were then cut from the strip of the activated carbon/binder compound after it had dried. However, as stated above, a polarizable electrode of the present invention can be of various shape and size. For example, the particular polarizable electrode **15** shown in Figures 1-2 and 4-5 has a length (height) of approximately 135mm, a width of approximately 70mm, and a thickness of approximately 1.4mm.

The polarizable electrode assembly **10** of the present invention also employs a current collector **20**. In the exemplary embodiment of the polarizable electrode assembly **10** shown in Figures 1 and 4-5, the current collector can be seen to include a conductive substrate in the form of a collector plate **25**, onto which is applied a protective coating **30**. It should be understood, however, that the size and/or shape of

the current collector **20** is not limited to that shown, but can vary as necessary to conform to the design of the capacitor to which it will be installed. For example, the conductive substrate can be of other shapes, such as a cylinder. It should also be understood that, for purposes of clarity, the thickness of the current collector components may be exaggerated in the drawing figures. For example, in the particular embodiment of the current collector **20** shown in Figures 1 and 3-5, the thickness of the collector plate **25** is actually only about 0.2mm, and the thickness of the protective coating is actually only about 7 μ m.

In the polarizable electrode assembly **10** of the present invention, the collector plate **25** resides between a pair of the polarizable electrodes **15**. The collector plate **25** may be comprised of a number of conductive metallic or non-metallic materials. For example, it is contemplated that the collector plate **25** may be manufactured from conductive materials such as lead, tantalum, niobium, silver, copper, bismuth, ruthenium, closely-packed graphites, or nitrides and carbides of various transition metals. However, due to its ability to meet various physical property requirements, and its low cost, it is preferred that the collector plate **25** of the present invention be comprised of lead or a lead compound. For example, in the particular embodiment of the current collector **20** shown in Figures 1 and 3-5, the collector plate **25** is formed from a compound consisting essentially of lead and approximately 3 weight percent of tin. Lead is preferable over steel because it is more stable in an acidic electrolyte.

While a lead-based collector plate **25** is more stable than steel in an acidic electrolyte, it is not fully resistant thereto. In fact, over time an acidic electrolyte can corrode or otherwise degrade a lead-based current collector plate, thereby resulting in decreased capacitor performance. Consequently, the lead-based collector plate **25** of the present invention is preferably provided with a protective coating **30**. Preferably, the protective coating **30** encases at least that portion of the collector plate **25** that will be exposed to the electrolyte of the capacitor to which it is installed. For example, in the exemplary embodiment of the electrode assembly **10** of the present invention, the protective coating **30** is applied to an area that corresponds substantially to an area of the collector plate **25** that will mate with each polarizable electrode **15**. As can be seen in Figures 4-5, it is this area of the polarizable electrode assembly **10** that is in substantial contact with the electrolyte of the exemplary DEL capacitor illustrated

therein.

The protective coating **30** applied to the collector plate **25** may have various compositions. Preferably, the protective coating **30** consists of a conductive composite that is stable in an acidic electrolyte, such as a sulfuric acid electrolyte. The conductive composite may be formed from a polymer base material and a conductive dope. Non-limiting examples of acceptable polymer base materials include: bitumen; tar; coal-tar pitch; halogenated polymers; polymers based on polyurethane; and organic silicon compounds. Non-limiting examples of acceptable conductive dopes include: carbon black; graphite; and carbon fiber. Preferably, the conductive dope comprises approximately 30-90 weight percent of the protective coating **30**. The conductive dope may comprise more or less than 30-90 weight percent of the protective coating **30**, but typically with undesirable consequences. For example, it has been found that with less than 30 weight percent of conductive dope, the conductivity of the protective coating **30** may become unsatisfactory. Similarly, it has been found that with greater than 90 weight percent of conductive dope, the level of protection provided by the protective coating **30** may be degraded. In an alternate embodiment of a current collector of the present invention, a protective coating may be prepared by mixing a monomer and oligomer (containing plasticizers and hardeners) with a conductive dope. In this embodiment, the polymer base may then be generated directly on the surface of the collector plate by the polymerization of the monomer and oligomer.

The protective coating **30** may be prepared and applied by a number of known methods. For example, initial preparation may include mixing the polymer base material with the conductive dope, and subsequent creation of a solution by introducing the mixture to a solvent. Application of the protective coating **30** to the collector plate **25** may be accomplished by traditional means. For example, the protective coating **30** may be applied to the collector plate **25** by brushing, rolling, dipping, screen printing, spraying, or other similar means of deposition. If a solvent was introduced to the protective coating material **30** prior to application, the solvent is preferably removed therefrom by drying after the protective coating has been applied. Further, a thermal treatment process may be used to improve adhesion between the protective coating **30** and the collector plate **25**, and/or the protective characteristics of the protective coating. A current collector **20** so produced is inexpensive and highly resistant to corrosion when

exposed to an acidic electrolyte. In addition, the protective coating 30 of the present invention is more reliable than other known methods of current collector protection, such as, for example, the adhesive bonding of a protective foil to a collector plate. Below, are several non-limiting examples of acceptable protective coating
5 compositions:

Example 1

A composite mixture comprising approximately 30 weight percent of a bitumen polymer and approximately 70 weight percent of a carbon black conductive dope was prepared. The composite was prepared in the presence of a heptane solvent to facilitate
10 application to the collector plate. The composite was thereafter applied to the collector plate and subsequently dried at approximately 60°C to remove the solvent. Thereafter, the composite-coated collector plate was thermally treated at a temperature of between about 120-140°C.

Example 2

A composite mixture comprising approximately 30 weight percent of a tar polymer and approximately 70 weight percent of a carbon black conductive dope was prepared. The composite was prepared in the presence of a heptane solvent to facilitate
15 application to the collector plate. The composite was thereafter applied to the collector plate and subsequently dried at approximately 60°C to remove the solvent. Thereafter, the composite-coated collector plate was thermally treated at a temperature of between
20 about 120-140°C.

Example 3

A composite mixture comprising approximately 25 weight percent of a cold-hardening chlorinated polymer and approximately 75 weight percent of a finely
25 dispersed graphite conductive dope was prepared. A suitable cold-hardening chlorinated polymer is available under the trade name of Remochlor. The composite was applied to the collector plate, and the composite-coated collector plate was subsequently thermally treated at a temperature of about 60°C.

Example 4

A composite mixture comprising approximately 25 weight percent of an organo-silicon polymer and approximately 75 weight percent of a finely dispersed fiber material
30 conductive dope was prepared. A suitable organo-silicon polymer is available under the

trade name of KP-303B from the BASF® company. An acceptable fiber material can be obtained by the graphitization of fossil coal. The composite was applied to the collector plate, and the composite-coated collector plate was subsequently thermally treated at a temperature of about 120°C-130°C.

5

Example 5

A composite mixture comprising approximately 25 weight percent of a polyurethane varnish-based polymer and approximately 75 weight percent of a finely dispersed fiber material conductive dope was prepared. A suitable polyurethane varnish-based polymer is available under the trade name CRAMOLIN® URETHANE-Clear, and can be obtained from ITW Chemische Produkte GmbH in Germany. An acceptable fiber material can be obtained by the graphitization of fossil coal. The composite was applied to the collector plate, and the composite-coated collector plate was subsequently thermally treated at a temperature of about 90°C.

Once the current collector **20** has been produced by sufficiently applying the protective coating **30** to the collector plate **25**, the polarizable electrodes **15** can be affixed thereto. The polarizable electrodes **15** of the present invention can be affixed to the protective coating **30** covered collector plate **25** by a number of means including, for purposes of illustration and not limitation, adhesive bonding and/or pressing/molding. The combination of the current collector **20** and the polarizable electrodes **15** form the exemplary polarizable electrode assembly **10** shown in Figures 1 and 4-5. While the exemplary embodiment of the polarizable electrode assembly **10** of Figures 1 and 4-5 is shown to have a polarizable electrode **15** on opposite sides of the collector plate **25**, it is also possible, depending on the design of the capacitor to which the polarizable electrode assembly will be installed, to locate a polarizable electrode on only one side of the collector plate.

The polarizable electrode assembly **10** is designed for use in an electrochemical capacitor. As the simplest example, such an electrochemical capacitor may have only two electrodes, separated by an electrolyte and possibly a separator. While it is possible to construct such a capacitor using two polarizable electrode assemblies **10**, it is preferred that a capacitor of the present invention have both a polarizable electrode assembly and a non-polarizable electrode assembly. Such an arrangement can be observed by specific reference to Figure 4. Figure 4 illustrates an exemplary, and

simplistic, embodiment of a DEL capacitor **50** of the present invention. As can be seen, a polarizable electrode assembly **10b** and a non-polarizable electrode assembly **55** reside on substantially opposite ends of a sealed enclosure **65**. The polarizable electrode assembly **10b** comprises a previously-described current collector **20** of the present invention, to which is affixed a single polarizable electrode **15**. The non-polarizable electrode assembly **55** comprises a previously-described current collector **20** of the present invention, to which is affixed a single non-polarizable electrode **60**. While other materials may be used to form a non-polarizable electrode of the present invention, the non-polarizable electrode **60** of the exemplary embodiment shown in Figure 4 is formed from a mixture of lead dioxide and lead sulfate. The non-polarizable electrode may be formed and affixed to its current collector **20** by any of a multitude of known techniques. The polarizable and non-polarizable electrodes **15**, **60** may be of symmetric or asymmetric design. More specifically, the polarizable and non-polarizable electrodes **15**, **60** may have a similar or dissimilar absolute capacitance. When a DEL capacitor of the present invention employs an asymmetric design, the absolute capacitance of the larger capacitance electrode is preferably at least 3 times and, more preferably, approximately 10 times the absolute capacitance of the smaller capacitance electrode.

As can be seen in Figure 4, the current collectors **20** of the polarizable and non-polarizable electrode assemblies **10b**, **55** are allowed to protrude through the enclosure **65** for proper electrical connection. The interface between the current collectors **20** and the enclosure **65** may be provided with a seal (not shown). A separator **70** may be located within the enclosure **65** to divide the hollow space between the electrode assemblies **10b**, **55**. The separator **70** may be formed from various materials. For example, the separator **70** may be formed of one of the variety of materials commonly utilized in the manufacture of separators lead-acid batteries. Whatever specific material is selected for creating the separator **70**, it should provide for a high level of oxygen transfer from the positive electrode to the negative electrode (i.e., from the non-polarizable electrode to the polarizable electrode in the embodiment of Figure 4), and also allow for the realization of an efficient oxygen cycle during charging of the capacitor. In the exemplary embodiment of Figure 4, the separator **70** is constructed of an ion-permeable glass material. The remaining hollow space within the enclosure **65** is substantially filled with an electrolyte **75**. Depending on the composition of the

electrodes **15**, **60**, a number of different electrolytes may be suitably employed in such a capacitor. In the exemplary embodiment of the DEL capacitor **50** shown in Figure 4, an aqueous sulfuric acid is utilized as the electrolyte **75**.

In operation, a voltage is applied to the DEL capacitor **50**. As the voltage is applied, oxidation/reduction reactions will occur at the interface of the non-polarizable electrode **60** and the electrolyte **75**. These oxidation/reduction reactions are the result of the Faradaic pseudocapacitive behavior of the non-polarizable electrode **60** and are responsible for charge transfer at the non-polarizable electrode. During voltage application, the polarizable electrode **15** will store electrical energy through a double layer electrochemical mechanism (a non-Faradaic process). In this process, a layer of electrons **80** will form at the electrode **15** side of the electrode/electrolyte interface, while a layer of positive ions **85** will form on the electrolyte side of the electrode/electrolyte interface. The voltage across this interface increases with charge accumulation, and is eventually released during discharge of the capacitor.

A multi-celled DEL capacitor **100** of the present invention can be observed in Figure 5. The multi-celled DEL capacitor **100** utilizes seven of the polarizable electrode assemblies **10** shown in Figure 1. The multi-celled DEL capacitor **100** also utilizes seven non-polarizable electrode assemblies **110**. The seven polarizable electrode assemblies **10** and the seven non-polarizable electrode assemblies **110** are located within an enclosure **125** in a spaced-apart, alternating relationship. Unlike the DEL capacitor **50** of Figure 4, the polarizable and non-polarizable electrode assemblies **10**, **110** of the DEL capacitor **100** of Figure 5 utilize a current collector **20** that is sandwiched between two electrodes **15**, **115**. Each of the non-polarizable electrode assemblies **110** is also shown to be substantially encased within a glass separator **120**. An aqueous sulfuric acid electrolyte **130** substantially fills the hollow space within the enclosure **125** and between the electrode assemblies **10**, **110**. The DEL capacitor **100** of the present invention operates in a manner similar to the DEL capacitor of Figure 4. However, due to the increased number of electrode assemblies **10**, **110** used, the overall storage capacity of the DEL capacitor **100** is increased.

The design of the polarizable electrode/electrode assembly allows for the construction of a DEL capacitor having improved energy storage capacity. For example, exemplary DEL test capacitors using a polarizable electrode assembly and lead-based

current collector, as described above, have exhibited an operating voltage of up to about 2.2 volts. In addition, these electrodes have exhibited a specific capacitance in the range of approximately 900-1,000 F/g when exposed to a sulfuric acid electrolyte. Therefore, DEL capacitors constructed according to the present invention can possess specific
5 energies of about 18-20 Wh/kg, or approximately 60 Wh/l.

While certain embodiments of the present invention are described in detail above, the scope of the invention is not to be considered limited by such disclosure, and modifications are possible without departing from the spirit of the invention as evidenced by the following claims:

WHAT IS CLAIMED IS:

1. An electrode for use in an electrochemical capacitor, said electrode consisting essentially of:

5 an active material comprising an activated carbon obtained from the carbonization and subsequent activation of a furane tar and/or a furane resin;

and

a binder consisting of a fluorine-containing polymer;

wherein said binder is present in said electrode in an amount of between about 0.5 and about 5.0 weight percent.

10 2. The electrode of claim 1, wherein said electrode is polarizable.

3. The electrode of claim 1, wherein said binder is added to said activated carbon as a fluoroplastic emulsion.

4. The electrode of claim 1, wherein the specific capacitance of said electrode is between about 900 and about 1,000 F/g in a sulfuric acid electrolyte.

15 5. An electrode assembly for use in an electrochemical capacitor, comprising:

at least one electrode consisting essentially of a composite mixture having an active material comprising an activated carbon obtained from the carbonization and subsequent activation of a furane tar and/or a furane resin, and a fluorine-containing polymer binder; and

20 a current collector, said current collector further comprising:

a substrate formed from an electrically conductive material,

and

a protective coating encasing at least a portion of said substrate that will be exposed to an electrolyte once said current collector is installed to said electrochemical capacitor, said protective coating consisting essentially of a composite having a polymer base material and a conductive dope,

wherein said at least one electrode is affixed to said substrate after said substrate is covered with said protective coating; and

wherein said protective coating is resistant to an acid-based electrolyte.

30 6. The electrode assembly of claim 5, wherein said at least one electrode is polarizable.

7. The electrode assembly of claim 5, wherein said conductive substrate of said

current collector comprises lead or a lead compound.

8. The electrode assembly of claim 7, wherein said conductive substrate of said current collector comprises a mixture of lead and tin.

9. The electrode assembly of claim 5, wherein said polymer base material of said protective coating is selected from the group consisting of bitumen, tar, coal-tar pitch, halogenated polymers, polymers based on polyurethane, and organic silicon polymers.

10. The electrode assembly of claim 5, wherein said conductive dope of said protective coating is selected from the group consisting of carbon black, graphite, and carbon fiber.

11. The electrode assembly of claim 5, further comprising the addition of an organic solvent to said composite protective coating.

12. The electrode assembly of claim 5, wherein said protective coating is applied to said substrate by a method selected from the group consisting of brushing, rolling, dipping, screen printing, and spraying.

13. The electrode assembly of claim 5, wherein said protective coating comprises a mixture of a monomer and an oligomer that contains plasticizers and hardeners, whereby, after application of said protective coating, said polymer base is generated directly on the surface of said substrate by the polymerization of said monomer and said oligomer.

14. The electrode assembly of claim 5, wherein resistant and adhesive properties of said protective coating are enhanced by exposure to a predetermined range of elevated temperatures.

15. The electrode assembly of claim 5, wherein said at least one electrode is affixed to said protective coating covered substrate by means of an adhesive.

16. The electrode assembly of claim 5, wherein said at least one electrode is affixed to said protective coating covered substrate by pressing.

17. The electrode assembly of claim 5, wherein said at least one electrode is affixed to said protective coating covered substrate by both an adhesive and pressing means.

18. The electrode assembly of claim 5, wherein said at least one electrode is molded onto said protective coating covered substrate during forming of said at least one electrode.

19. The electrode assembly of claim 5, wherein said protective coating is resistant to sulfuric acid.

20. A double electric layer electrochemical capacitor, comprising:

at least one polarizable electrode assembly, said polarizable electrode assembly
5 further comprising:

(a) at least one electrode comprising a composite mixture having an active material consisting essentially of an activated carbon obtained from the carbonization and subsequent activation of a furane tar and/or a furane resin, and a fluorine-containing polymer binder; and

10 (b) a current collector, said current collector further comprising:

a substrate formed from an electrically conductive material,

and a protective coating encasing at least a portion of said substrate that will be exposed to an electrolyte once said current collector is installed to said electrochemical capacitor, said protective coating consisting essentially of a composite having a polymer
15 base material and a conductive dope that is resistant to an acid-based electrolyte,

at least one non-polarizable electrode assembly, said non-polarizable electrode assembly further comprising:

(a) at least one non-polarizable electrode consisting essentially of a composite mixture of a metal dioxide and a metal sulfate;

20 and

(b) a current collector, said current collector further comprising:

a substrate formed from an electrically conductive material,

and a protective coating encasing at least a portion of said substrate that will be exposed to an electrolyte once said current collector is installed to said electrochemical
25 capacitor, said protective coating consisting essentially of a composite having a polymer base material and a conductive dope that is resistant to an acid-based electrolyte,

an enclosure for housing both said at least one polarizable electrode assembly and said at least one non-polarizable electrode assembly;

at least one separator within said enclosure for separating said at least one
30 polarizable electrode assembly from said at least one non-polarizable electrode assembly; and

an acid-based electrolyte residing within said enclosure and between said at least

one polarizable electrode assembly and said at least one non-polarizable electrode assembly;

wherein charge storage is accomplished at said at least one polarizable electrode assembly by means of a non-Faradaic, double layer electrochemical mechanism that occurs at an interface of said polarizable electrode and said electrolyte; and

wherein said charge storage is accomplished at said at least one non-polarizable electrode assembly by means of oxidation/reduction reactions that occur at an interface between said non-polarizable electrode and said electrolyte.

21. The double layer electrochemical capacitor of claim 20, wherein said conductive substrate of said current collector comprises lead or a lead compound.

22. The double layer electrochemical capacitor of claim 21, wherein said conductive substrate of said current collector comprises a mixture of lead and tin.

23. The double layer electrochemical capacitor of claim 20, wherein said at least one non-polarizable electrode consists essentially of a mixture of lead dioxide and lead sulfate.

24. The double layer electrochemical capacitor of claim 20, wherein said enclosure is sealed.

25. The double layer electrochemical capacitor of claim 20, wherein said separator envelops at least a portion of each of said non-polarizable electrode assemblies.

26. The double layer electrochemical capacitor of claim 20, wherein said separator is a glass material.

27. The double layer electrochemical capacitor of claim 26, wherein said glass material is ion-permeable.

28. The double layer electrochemical capacitor of claim 20, wherein said polarizable and said non-polarizable electrodes are asymmetric with respect to absolute capacitance.

29. The double layer electrochemical capacitor of claim 28, wherein the larger capacitance electrode has an absolute capacitance that is at least three times and, more preferably, approximately ten times the absolute capacitance of the smaller capacitance electrode.

30. The double layer electrochemical capacitor of claim 20, wherein said acid-

based electrolyte is sulfuric acid.

31. The double layer electrochemical capacitor of claim 20, wherein said polarizable and said non-polarizable electrodes are arranged in a substantially uniformly spaced and alternating relationship.

5 32. A double electric layer electrochemical capacitor, comprising:
a plurality of polarizable electrode assemblies, each of said polarizable electrode assemblies comprising:

10 (a) at least one electrode consisting essentially of a composite mixture having an active material comprising an activated carbon obtained from the carbonization and subsequent activation of a furane tar and/or a furane resin, and a fluorine-containing polymer binder; and

(b) a current collector, said current collector further comprising:
a substrate formed from an electrically conductive material,
and a protective coating encasing at least a portion of said substrate that will be
15 exposed to an electrolyte once said current collector is installed to said electrochemical capacitor, said protective coating consisting essentially of a composite having a polymer base material and a conductive dope that is resistant to an acid-based electrolyte,
an enclosure for housing both said plurality of polarizable electrode assemblies;
at least one separator within said enclosure for separating said plurality of
20 polarizable electrode assemblies; and

an acid-based electrolyte residing within said enclosure and between said plurality of polarizable electrode assemblies;

25 wherein charge storage is accomplished at each of said plurality of polarizable electrode assemblies by means of a non-Faradaic, double layer electrochemical mechanism that occurs at an interface of said polarizable electrode and said electrolyte.

AMENDED CLAIMS

[received by the International Bureau on 29 May 2006 (29.05.2006)]

1. An electrode for use in an electrochemical capacitor, said electrode consisting essentially of:

5 a mixture of an active material and a binder, said active material comprising an activated carbon obtained from the carbonization and subsequent activation of a furane tar and/or a furane resin, said binder comprising between about 0.5 and about 5.0 weight percent of a fluorine-containing polymer; and

10 a current collector having a substrate formed from an electrically conductive material, at least a portion of said substrate encased within an acid-resistant protective coating consisting essentially of a composite having a polymer base material and a conductive dope.

2. The electrode of claim 1, wherein said electrode is polarizable.

3. The electrode of claim 1, wherein said binder is added to said activated carbon as a fluoroplastic emulsion.

15 4. The electrode of claim 1, wherein the specific capacitance of said electrode is between about 900 and about 1,000 F/g in a sulfuric acid electrolyte.

5. An electrode assembly for use in an electrochemical capacitor, comprising:
at least one electrode consisting essentially of a composite mixture having an active material comprising an activated carbon obtained from the carbonization and
20 subsequent activation of a furane tar and/or a furane resin, and a fluorine-containing polymer binder; and

a current collector, said current collector further comprising:
a substrate formed from an electrically conductive material, and
a protective coating encasing at least a portion of said substrate that will be
25 exposed to an electrolyte once said current collector is installed to said electrochemical capacitor, said protective coating consisting essentially of a composite having a polymer base material and a conductive dope,

wherein said at least one electrode is affixed to said substrate after said substrate is covered with said protective coating; and

30 wherein said protective coating is resistant to an acid-based electrolyte.

6. The electrode assembly of claim 5, wherein said at least one electrode is polarizable.

7. The electrode assembly of claim 5, wherein said conductive substrate of said current collector comprises lead or a lead compound.

8. The electrode assembly of claim 7, wherein said conductive substrate of said current collector comprises a mixture of lead and tin.

5 9. The electrode assembly of claim 5, wherein said polymer base material of said protective coating is selected from the group consisting of bitumen, tar, coal-tar pitch, halogenated polymers, polymers based on polyurethane, and organic silicon polymers.

10 10. The electrode assembly of claim 5, wherein said conductive dope of said protective coating is selected from the group consisting of carbon black, graphite, and carbon fiber.

11. The electrode assembly of claim 5, further comprising the addition of an organic solvent to said composite protective coating.

15 12. The electrode assembly of claim 5, wherein said protective coating is applied to said substrate by a method selected from the group consisting of brushing, rolling, dipping, screen printing, and spraying.

20 13. The electrode assembly of claim 5, wherein said protective coating comprises a mixture of a monomer and an oligomer that contains plasticizers and hardeners, whereby, after application of said protective coating, said polymer base is generated directly on the surface of said substrate by the polymerization of said monomer and said oligomer.

14. The electrode assembly of claim 5, wherein resistant and adhesive properties of said protective coating are enhanced by exposure to a predetermined range of elevated temperatures.

25 15. The electrode assembly of claim 5, wherein said at least one electrode is affixed to said protective coating covered substrate by means of an adhesive.

16. The electrode assembly of claim 5, wherein said at least one electrode is affixed to said protective coating covered substrate by pressing.

30 17. The electrode assembly of claim 5, wherein said at least one electrode is affixed to said protective coating covered substrate by both an adhesive and pressing means.

18. The electrode assembly of claim 5, wherein said at least one electrode is molded onto said protective coating covered substrate during forming of said at least

one electrode.

19. The electrode assembly of claim 5, wherein said protective coating is resistant to sulfuric acid.

20. A double electric layer electrochemical capacitor, comprising:

5 at least one polarizable electrode assembly, said polarizable electrode assembly further comprising:

(a) at least one electrode comprising a composite mixture having an active material consisting essentially of an activated carbon obtained from the carbonization and subsequent activation of a furane tar and/or a furane resin, and a fluorine-containing
10 polymer binder; and

(b) a current collector, said current collector further comprising:

a substrate formed from an electrically conductive material,

and a protective coating encasing at least a portion of said substrate that will be exposed to an electrolyte once said current collector is installed to said electrochemical
15 capacitor, said protective coating consisting essentially of a composite having a polymer base material and a conductive dope that is resistant to an acid-based electrolyte,

at least one non-polarizable electrode assembly, said non-polarizable electrode assembly further comprising:

(a) at least one non-polarizable electrode consisting essentially of a composite
20 mixture of a metal dioxide and a metal sulfate;

and

(b) a current collector, said current collector further comprising:

a substrate formed from an electrically conductive material,

and a protective coating encasing at least a portion of said substrate that will be
25 exposed to an electrolyte once said current collector is installed to said electrochemical capacitor, said protective coating consisting essentially of a composite having a polymer base material and a conductive dope that is resistant to an acid-based electrolyte,

an enclosure for housing both said at least one polarizable electrode assembly and said at least one non-polarizable electrode assembly;

30 at least one separator within said enclosure for separating said at least one polarizable electrode assembly from said at least one non-polarizable electrode assembly; and

an acid-based electrolyte residing within said enclosure and between said at least one polarizable electrode assembly and said at least one non-polarizable electrode assembly;

wherein charge storage is accomplished at said at least one polarizable electrode assembly by means of a non-Faradaic, double layer electrochemical mechanism that occurs at an interface of said polarizable electrode and said electrolyte; and

wherein said charge storage is accomplished at said at least one non-polarizable electrode assembly by means of oxidation/reduction reactions that occur at an interface between said non-polarizable electrode and said electrolyte.

10 21. The double layer electrochemical capacitor of claim 20, wherein said conductive substrate of said current collector comprises lead or a lead compound.

22. The double layer electrochemical capacitor of claim 21, wherein said conductive substrate of said current collector comprises a mixture of lead and tin.

15 23. The double layer electrochemical capacitor of claim 20, wherein said at least one non-polarizable electrode consists essentially of a mixture of lead dioxide and lead sulfate.

24. The double layer electrochemical capacitor of claim 20, wherein said enclosure is sealed.

20 25. The double layer electrochemical capacitor of claim 20, wherein said separator envelops at least a portion of each of said non-polarizable electrode assemblies.

26. The double layer electrochemical capacitor of claim 20, wherein said separator is a glass material.

25 27. The double layer electrochemical capacitor of claim 26, wherein said glass material is ion-permeable.

28. The double layer electrochemical capacitor of claim 20, wherein said polarizable and said non-polarizable electrodes are asymmetric with respect to absolute capacitance.

30 29. The double layer electrochemical capacitor of claim 28, wherein the larger capacitance electrode has an absolute capacitance that is at least three times and, more preferably, approximately ten times the absolute capacitance of the smaller capacitance electrode.

30. The double layer electrochemical capacitor of claim 20, wherein said acid-based electrolyte is sulfuric acid.

31. The double layer electrochemical capacitor of claim 20, wherein said polarizable and said non-polarizable electrodes are arranged in a substantially uniformly spaced and alternating relationship.

32. A double electric layer electrochemical capacitor, comprising:
a plurality of polarizable electrode assemblies, each of said polarizable electrode assemblies comprising:

(a) at least one electrode consisting essentially of a composite mixture having an active material comprising an activated carbon obtained from the carbonization and subsequent activation of a furane tar and/or a furane resin, and a fluorine-containing polymer binder; and

(b) a current collector, said current collector further comprising:
a substrate formed from an electrically conductive material,
and a protective coating encasing at least a portion of said substrate that will be exposed to an electrolyte once said current collector is installed to said electrochemical capacitor, said protective coating consisting essentially of a composite having a polymer base material and a conductive dope that is resistant to an acid-based electrolyte,
an enclosure for housing both said plurality of polarizable electrode assemblies;
at least one separator within said enclosure for separating said plurality of polarizable electrode assemblies; and
an acid-based electrolyte residing within said enclosure and between said plurality of polarizable electrode assemblies;

wherein charge storage is accomplished at each of said plurality of polarizable electrode assemblies by means of a non-Faradaic, double layer electrochemical mechanism that occurs at an interface of said polarizable electrode and said electrolyte.

current collector, as described above, have exhibited an operating voltage of up to about 2.2 volts. In addition, these electrodes have exhibited a specific capacitance in the range of approximately 900-1,000 F/g when exposed to a sulfuric acid electrolyte. Therefore, DEL capacitors constructed according to the present invention can possess specific
5 energies of about 18-20 Wh/kg, or approximately 60 Wh/l.

While certain embodiments of the present invention are described in detail above, the scope of the invention is not to be considered limited by such disclosure, and modifications are possible without departing from the scope of the invention as evidenced by the following claims:

10

1/5

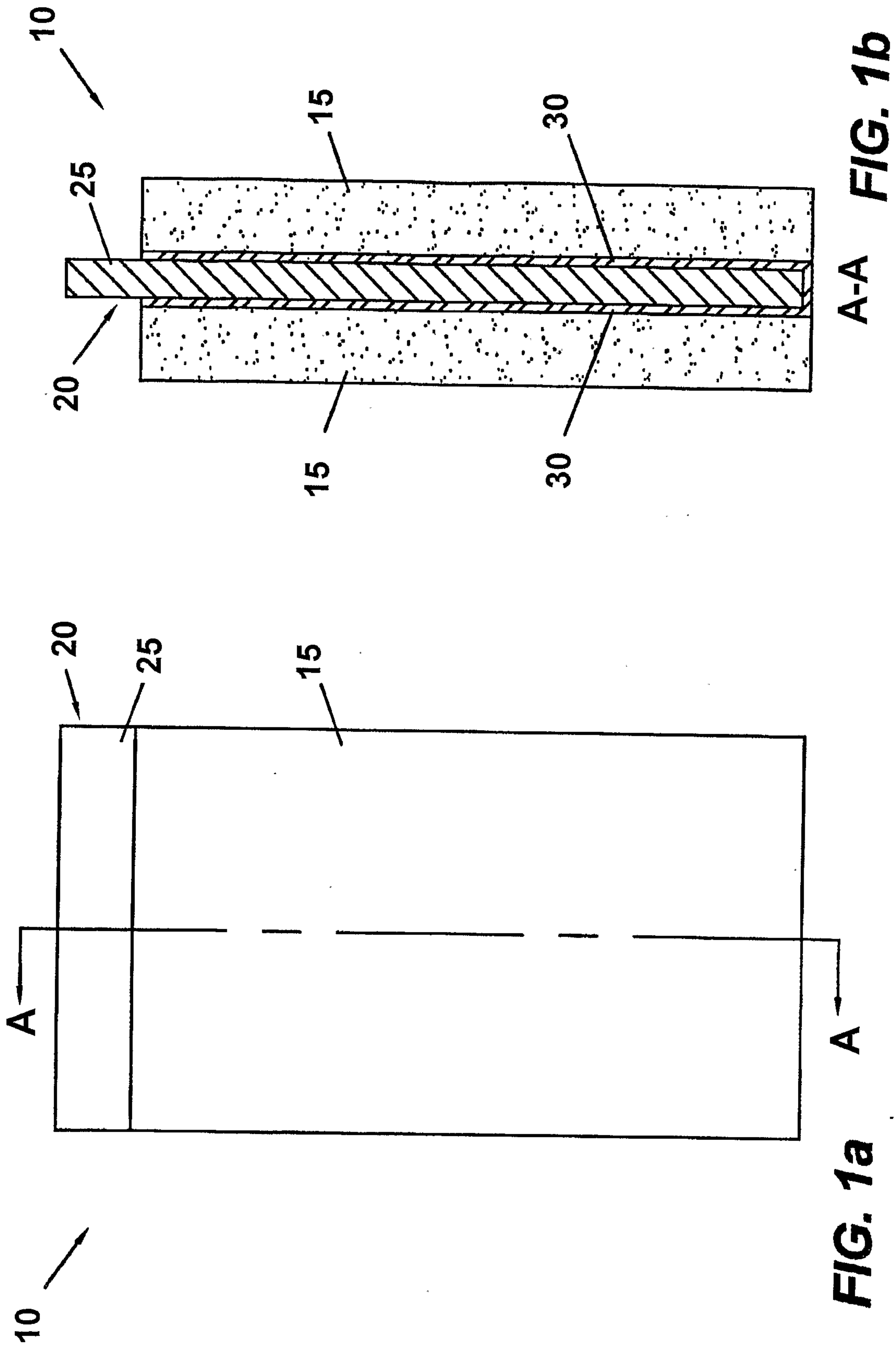

2/5

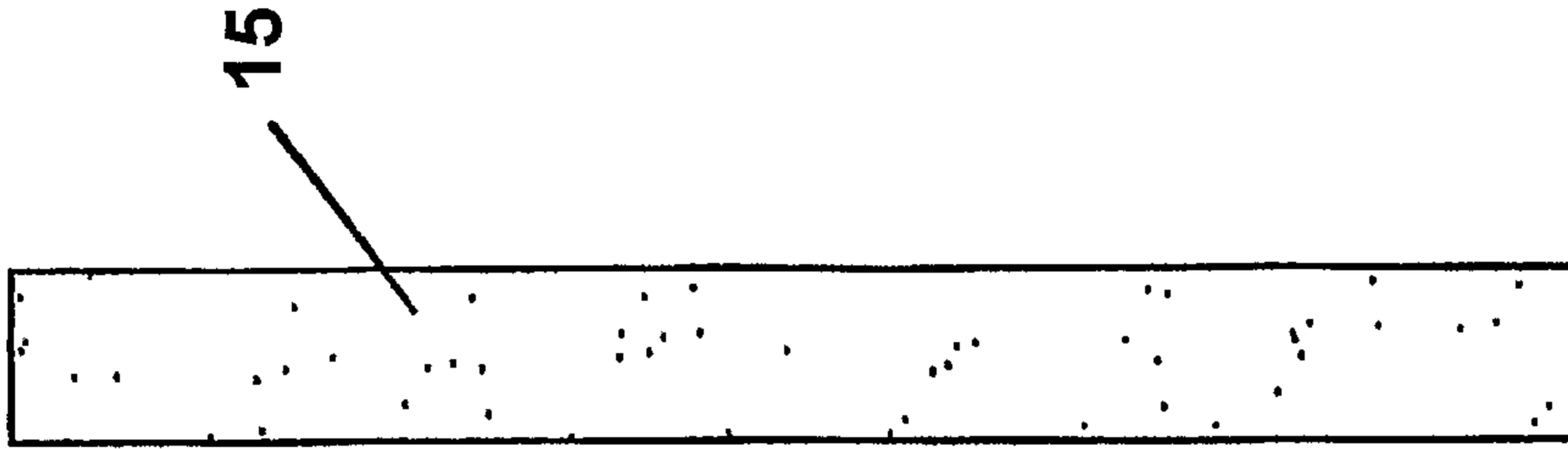

FIG. 2b

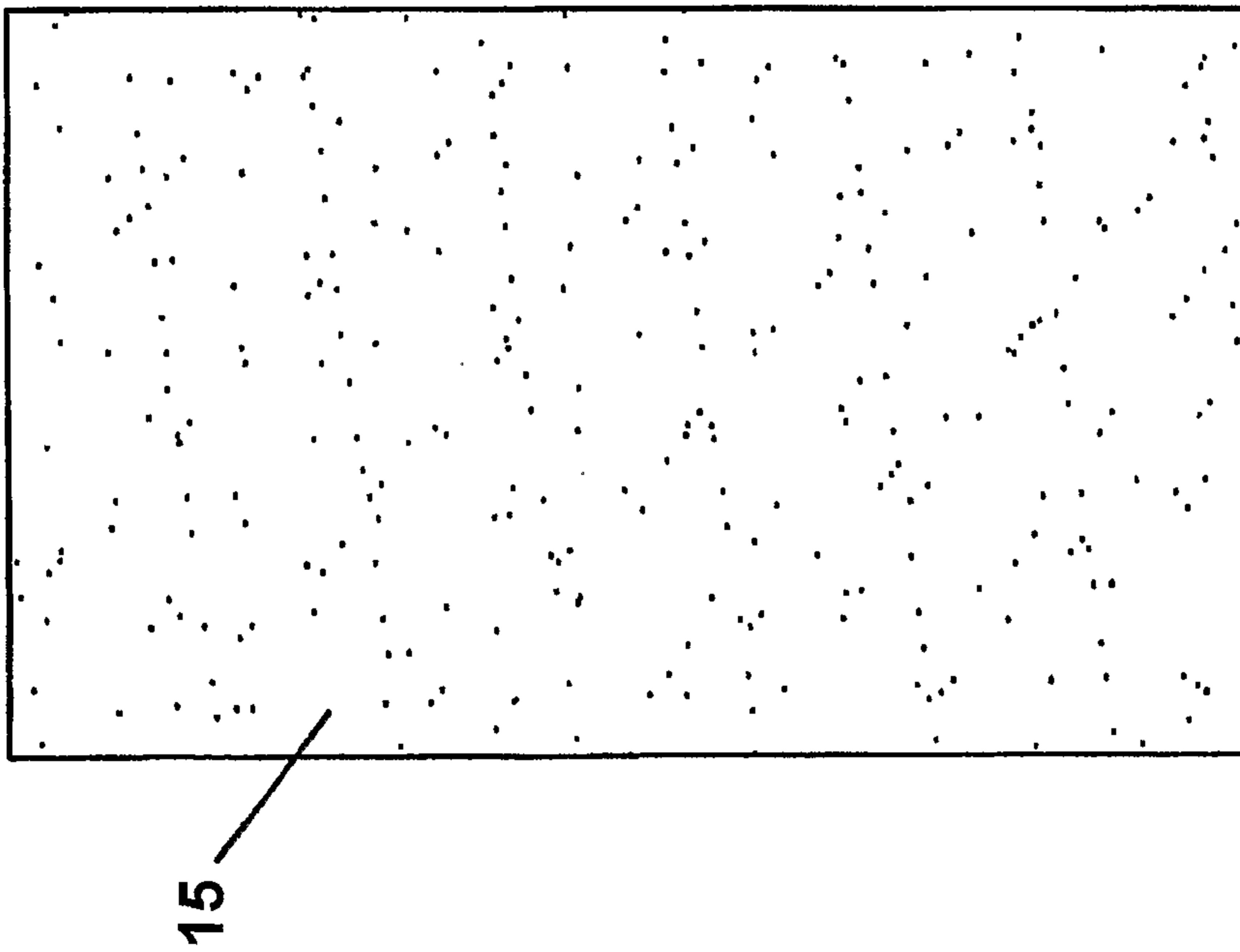
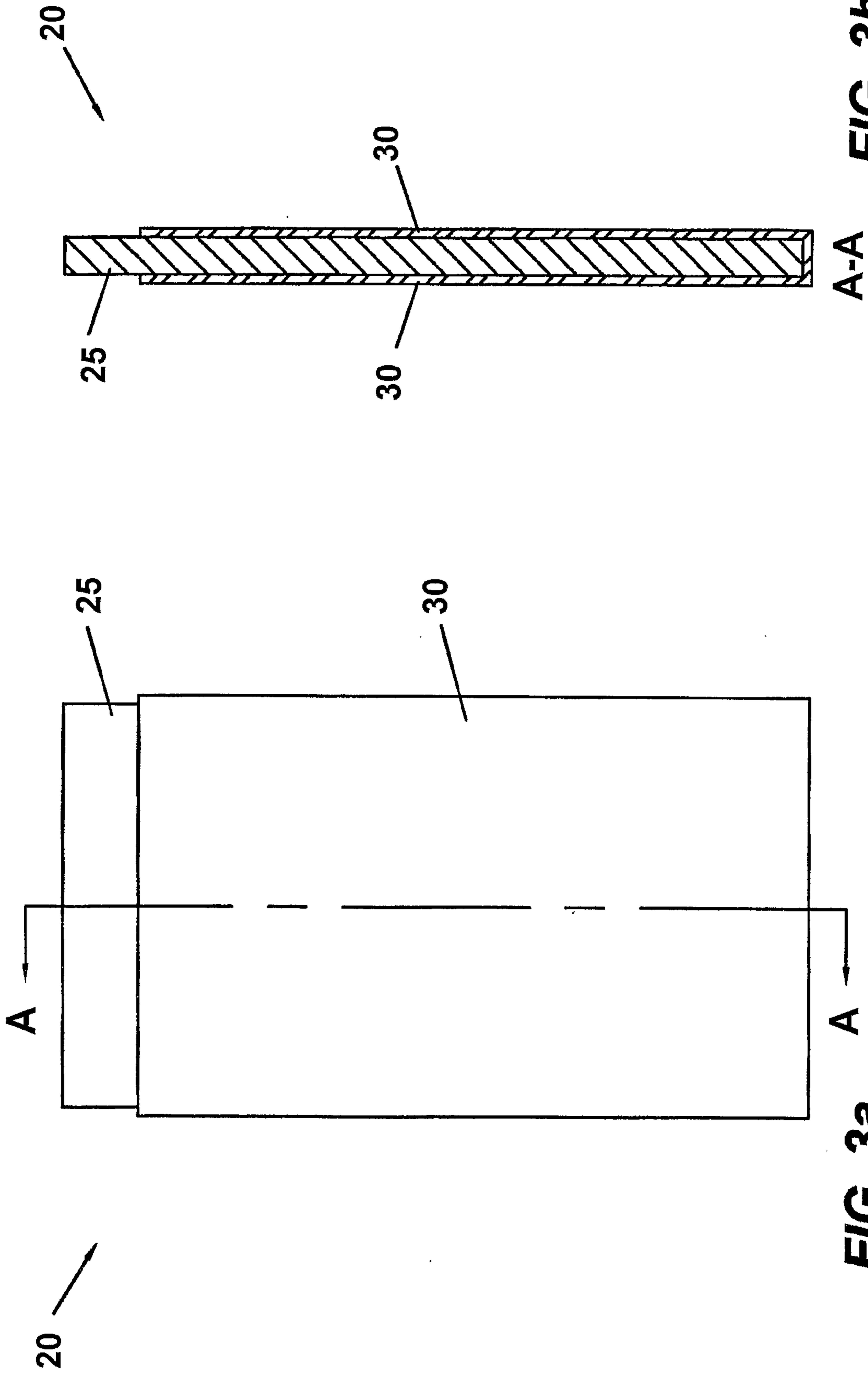

FIG. 2a

3/5



A-A FIG. 3b

FIG. 3a

4/5

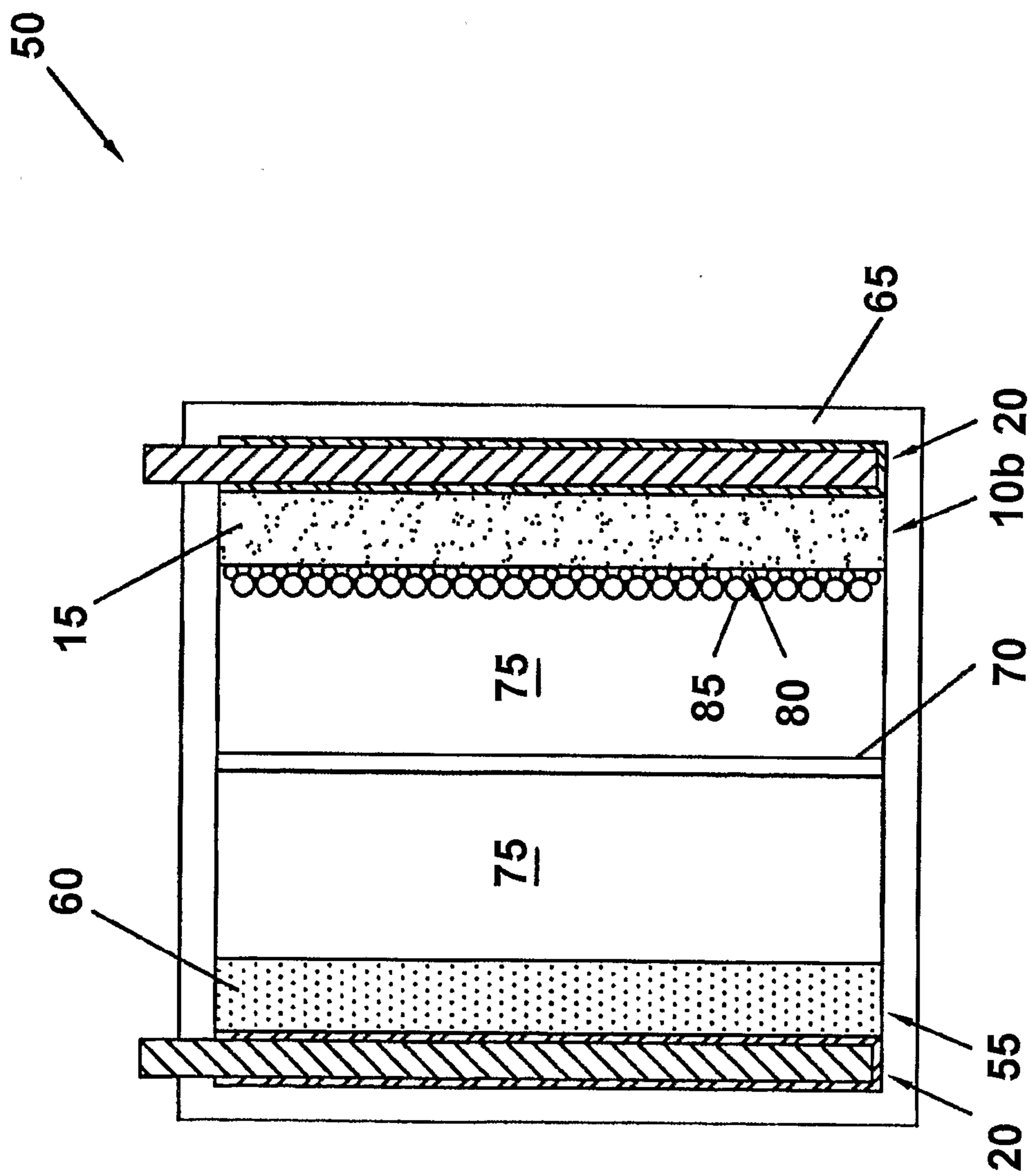

FIG. 4

5/5

100

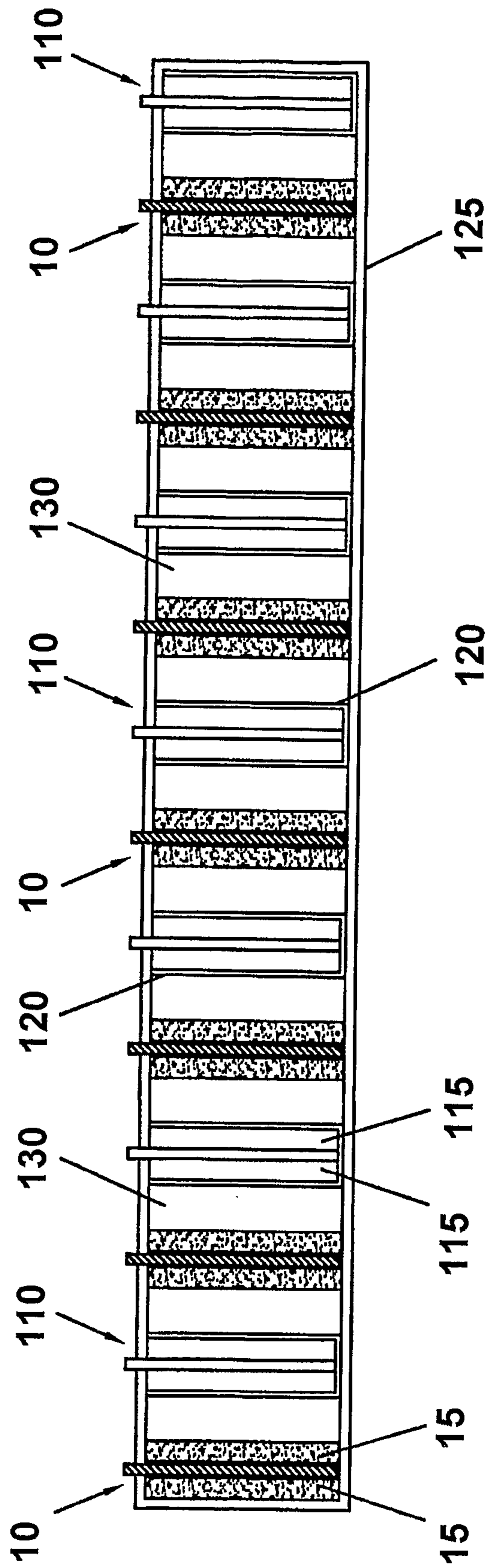

FIG. 5

