

G. F. WELIVAR.  
AUTOMATIC GOVERNOR.  
APPLICATION FILED JAN. 11, 1904.

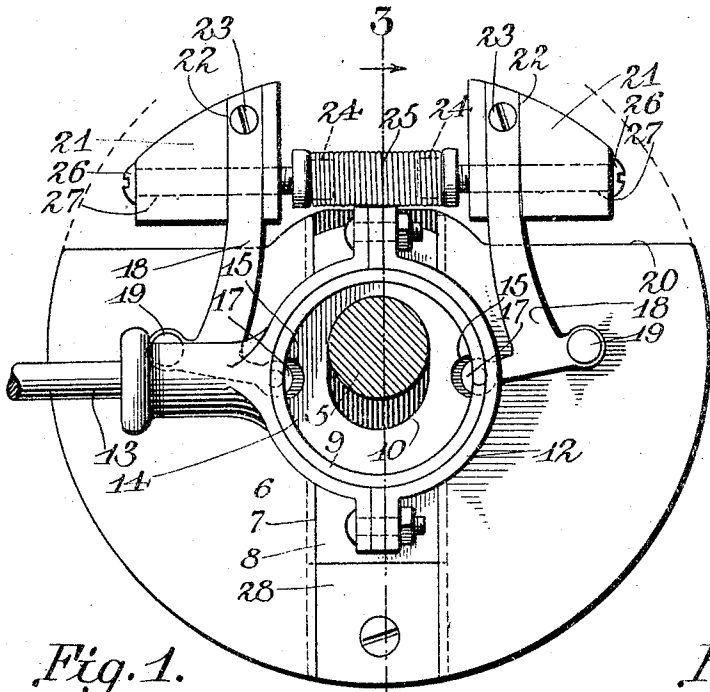

Fig. 1.

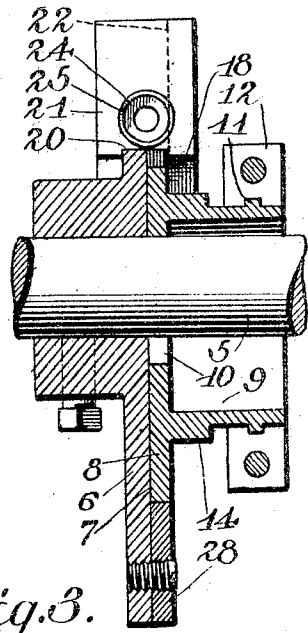

Fig. 3.

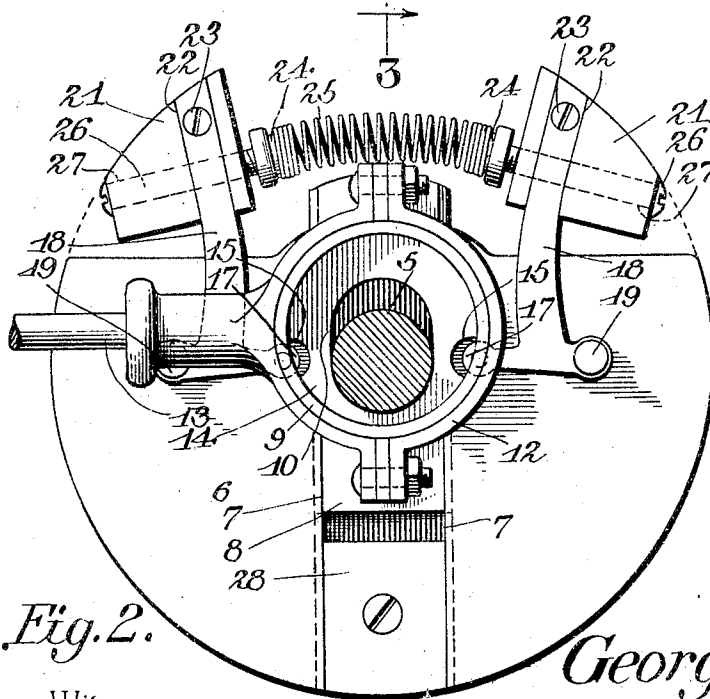

Fig. 2.

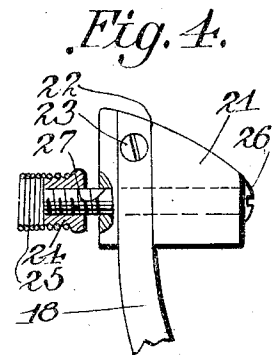

Fig. 4.

Witnesses  
*E. J. Stewart*  
*S. N. McKee*

George F. Welivar,  
Inventor.  
by *C. A. Snow & Co.*  
Attorneys

# UNITED STATES PATENT OFFICE.

GEORGE F. WELIVAR, OF CLEARFIELD, PENNSYLVANIA.

## AUTOMATIC GOVERNOR.

SPECIFICATION forming part of Letters Patent No. 778,930, dated January 3, 1905.

Application filed January 11, 1904. Serial No. 188,647.

*To all whom it may concern:*

Be it known that I, GEORGE F. WELIVAR, a citizen of the United States, residing at Clearfield, in the county of Clearfield and State of Pennsylvania, have invented a new and useful Automatic Governor, of which the following is a specification.

This invention relates to an improved governor for steam-engines, and has for its object to provide an inexpensive, durable, and efficient device of this character for automatically regulating the speed of the engine by controlling the admission of steam to the cylinder or cylinders.

A further object of the invention is to mount the eccentric operating the slide-valve on a guide-plate arranged to slide endwise on a disk or support attached to and rotating with the shaft so that the eccentric may be moved in a straight line at right angles to the shaft.

A still further object is to mount the governor-weights above the disk or support so as to form, in effect, a counterbalance and cause the weight thereof to be equally distributed, thus allowing the governor to perfectly control the shifting of the eccentric at all times.

The invention consists in the construction and novel combination and arrangement of parts hereinafter fully described, illustrated in the accompanying drawings, and pointed out in the claims hereto appended, it being understood that various changes in form, proportion, and minor details of construction may be resorted to without departing from the principle or sacrificing any of the advantages of this invention.

In the accompanying drawings, Figure 1 is a side elevation of a governor constructed in accordance with my invention, showing the relative position of the parts under normal conditions. Fig. 2 is a similar view showing the relative position of the parts when the speed of the engine is increased. Fig. 3 is a vertical sectional view taken on the line 3 3 of Fig. 1. Fig. 4 is a detail sectional view of the spring and adjusting-screw.

Similar numerals of reference indicate cor-

responding parts in all the figures of the drawings.

5 designates the shaft of an engine, to which is keyed or otherwise rigidly secured a segmental plate or disk 6, which forms a support for the governor. The disk or support 6 is provided with a dovetailed groove or channel 7, in which is slidably mounted a correspondingly-shaped guide-plate 8, preferably formed integral with the eccentric 9, as shown, and by means of which the eccentric may be moved in a straight line at right angles to the axis of the shaft. The eccentric is formed with a slot or opening 10, through which the shaft is inserted, and is provided with a ribbed collar or extension 11, upon which the eccentric-strap 12 is mounted, said strap being connected by a rod 13 with the stem of a slide-valve so as to throw the valve, and thus control the admission of steam to the engine cylinder or cylinders. The base of the eccentric is provided with an annular enlargement 14, having oppositely-disposed slots or recesses 15 formed therein, adapted to receive the circular heads 17 of bell-crank levers 18, pivoted, as indicated at 19, to the disk or support 6. The periphery of the disk or support is cut away, as shown at 20, and mounted above the edge of the disk at said cut-away portion and secured to the long arms of the bell-crank levers 18 are governor-weights 21, adapted to be thrown outwardly by centrifugal force and move the eccentric to automatically control the admission of steam to the cylinders when the speed of the engine becomes excessive. By having the governor-weights mounted above the disk or support in the manner described they serve to counterbalance the disk and cause the weight to be equally distributed. The ends of the levers 18 are preferably seated in recesses 22, formed in the weights 21, said arms being secured therein in any suitable manner, as by screws 23. Interposed between the weights 21 and fastened in any suitable manner to collars 24 is a preferably coiled spring 25, the tendency of which is to draw the weights toward each other, said spring being held in position and the tension thereof reg-

ulated by means of adjusting-screws 26, passing through longitudinal openings 27 and engaging the interior threads of the collars. Secured within the groove or channel 7 at a point adjacent the periphery of the disk 6 is a block 28, which forms a stop for the guide-plate 8 and also serves to receive the thrust of said plate.

In practice as the speed of the engine increases the levers 18, carrying the governor-weights 21, will be thrown outwardly by centrifugal force against the tension of the spring 25, causing the arms to shift the plate 8 and eccentric 9, and thereby automatically cut off the supply of steam to the cylinders. As the speed decreases the spring will draw the arms toward each other and move the eccentric to admit steam to the cylinders. The tension of the coiled spring may be regulated to vary the throw of the governor-weights, and consequently the movement of the eccentric, by adjusting the screws, as will be readily understood. Inasmuch as the governor-arms occupy the position of and are of a weight approximately equal to the weight of the several sections of the disk they effectually counterbalance said disk, while the limit of outward movement of the arms being within the lines of the disk they offer practically no resistance to the rotary movement of the governor.

Having thus described the invention, what is claimed is—

1. The combination with a shaft, of a supporting-disk secured to the shaft and having a portion of its periphery cut away, an eccentric slidably mounted on the disk, and governor-arms pivoted to said disk for reciprocating the eccentric and having their weighted ends occupying the cut-away portion of the disk to thereby form a counterbalance for the latter.

2. The combination with a shaft, of a supporting-disk secured to the shaft and having a portion of its periphery cut away, an eccentric, a guide-plate carrying the eccentric slidably mounted on the disk, governor-arms pivoted to said disk for reciprocating the guide-plate and having their weighted ends occupying the cut-away portion of the disk to thereby form a counterbalance for the latter, a spring interposed between the gov-

ernor-arms, and means for regulating the tension of the spring.

3. The combination with a shaft, of a supporting-disk secured to the shaft and having a portion of its periphery cut away, an eccentric slidably mounted on the disk, and weighted bell-crank levers pivoted to said disk for reciprocating the eccentric and having their weighted ends occupying the cut-away portion of the disk to thereby form a counterbalance for the latter.

4. The combination of a shaft, a support secured thereto, an eccentric slidably mounted on the support, weighted arms pivoted to the support for reciprocating the eccentric, a spring provided with terminal collars interposed between the weighted arms, and threaded pins passing through the weighted end of the arms and engaging the terminal collars for adjusting the tension of the spring.

5. The combination of a shaft, a support provided with a groove or channel secured thereto, a plate slidably mounted in said groove or channel, an eccentric having oppositely-disposed slots or recesses formed therein carried by the plate and movable therewith, weighted bell-crank levers pivoted to the support and engaging the slots in the eccentric, a spring connecting the weighted levers and adjusting-screws for regulating the tension of said spring.

6. The combination of a shaft, a support provided with a groove or channel secured to the shaft, an eccentric provided with oppositely-disposed slots or recesses slidably mounted in said groove or channel, bell-crank levers pivoted to the support and having their short arms engaging the slots in the eccentric and their long arms provided with detachable weights, there being recesses formed in said weights for the reception of said levers, a spring interposed between the weighted ends of the levers and means for adjusting the tension of the spring.

In testimony that I claim the foregoing as my own I have hereto affixed my signature in the presence of two witnesses.

GEORGE F. WELIVAR.

Witnesses:

FRANK TOOT,  
O. P. CONKLIN.