

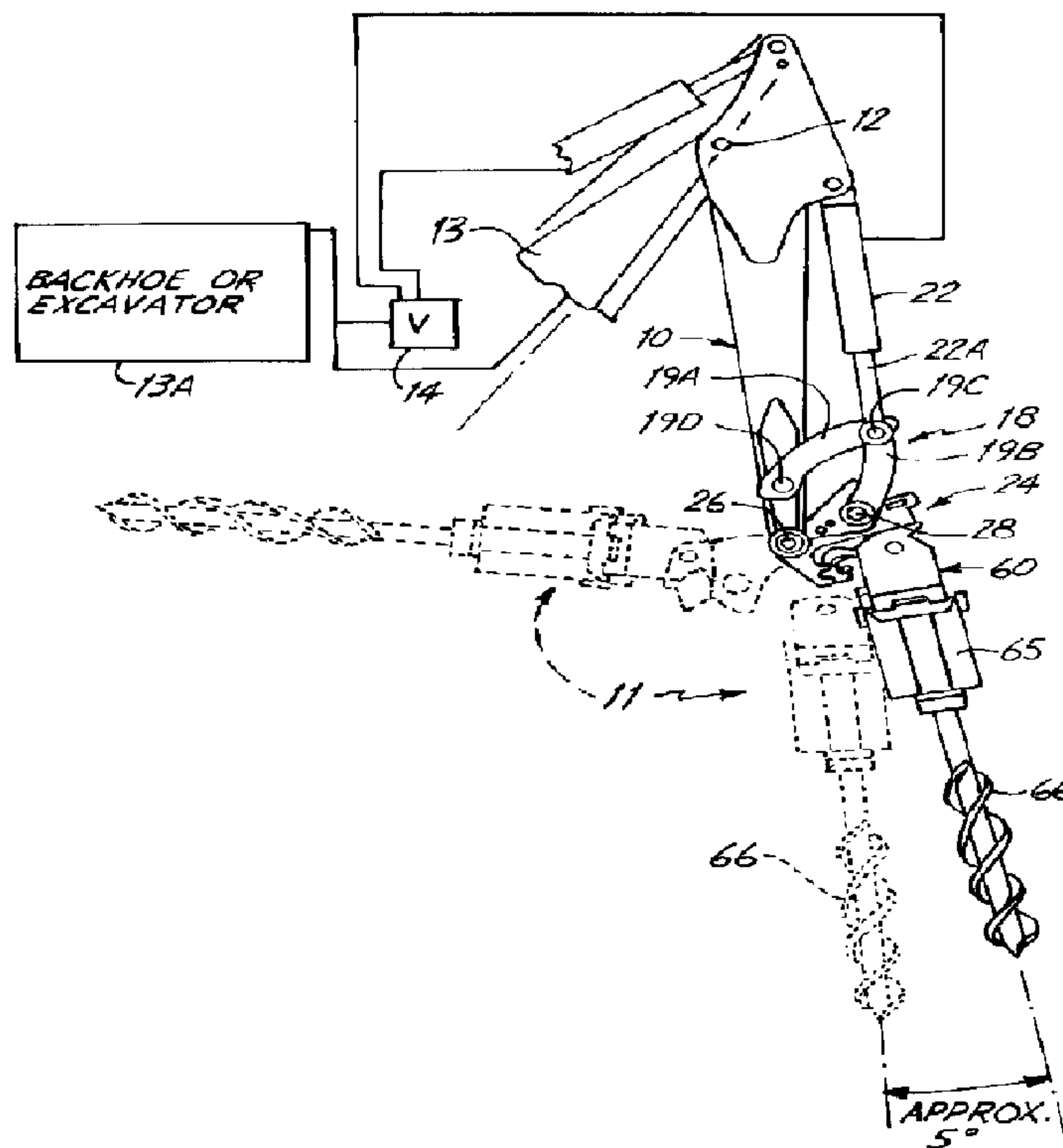

(22) Date de dépôt/Filing Date: 1999/02/11  
 (41) Mise à la disp. pub./Open to Public Insp.: 1999/08/24  
 (45) Date de délivrance/Issue Date: 2004/11/02  
 (30) Priorité/Priority: 1998/02/24 (09/028,794) US

(51) Cl.Int.<sup>6</sup>/Int.Cl.<sup>6</sup> E02F 3/96  
 (72) Inventeurs/Inventors:  
 BERARD, CRAIG A., US;  
 KACZMARSKI, WALLY L., US  
 (73) Propriétaire/Owner:  
 CLARK EQUIPMENT COMPANY, US  
 (74) Agent: BORDEN LADNER GERVAIS LLP

(54) Titre : ACCESSOIRE A CHANGEMENT RAPIDE POUR OUTIL MECANIQUE AUXILIAIRE  
 (54) Title: QUICK CHANGE ATTACHMENT FOR POWERED AUXILIARY TOOL



(57) Abrégé/Abstract:

A quick attach accessory tool adapter frame (20,48) is adapted to be mounted onto a quick attachment bracket (24) and held in place. The adapter frame (20,48) has plates (50) mounting a hub (53) to pivotally mount a powered auxiliary tool (11) on a hanger (60). The hanger is formed with spaced plates (60A, 60B) having upper edges (67,68) that will abut against portions of the adapter frame (20,48) to permit only limited pivotal movement of a tool (11) supported by the hanger (60) about a horizontal axis such that the operator can control the position of the tool (11) after the hanger (60) has pivoted against provided stops (49,52H) that limit the pivotal movement of the tool (11) about one axis.

**QUICK CHANGE ATTACHMENT FOR POWERED  
AUXILIARY TOOL**

ABSTRACT OF THE DISCLOSURE

A quick attach accessory tool adapter frame (20,48) is adapted to be mounted onto a quick attachment bracket (24) and held in place. The adapter frame (20,48) has plates (50) mounting a hub (53) to pivotally mount a powered auxiliary tool (11) on a hanger (60). The hanger is formed with spaced plates (60A,60B) having upper edges (67,68) that will abut against portions of the adapter frame (20,48) to permit only limited pivotal movement of a tool (11) supported by the hanger (60) about a horizontal axis such that the operator can control the position of the tool (11) after the hanger (60) has pivoted against provided stops (49,52H) that limit the pivotal movement of the tool (11) about one axis.

-1-

## QUICK CHANGE ATTACHMENT FOR POWERED AUXILIARY TOOL

### BACKGROUND OF THE INVENTION

5 The present invention relates to a mounting  
for a power driven auxiliary tool such as an earth auger  
that will permit quick attachment to an arm, such as a  
backhoe or excavator arm, using an adapter bracket that  
permits limited free pivotal movement of the accessory  
tool about an axis during operation.

10 The use of earth augers or other powered  
auxiliary tools, such as a plate compactor, mounted on  
a skid steer loader backhoe or an excavator arm is  
known. It is generally desirable to have some free  
pivotal movement for the power tool about a horizontal  
15 axis, as explained in U.S. Patent No. 5,556,217. Patent  
'217 discloses an auger mount using a slot to permit  
some pivotal movement so that the auger can come to a  
vertical position under gravity and also move as it  
bores into the ground. It is desirable to have control  
20 over the pivotal position of the auger, after limited  
pivoting has occurred.

The support shown in Patent No. 5,556,217 is  
pinned in place, which requires changing of pivot pins  
if a different attachment is to be coupled to the  
25 backhoe or excavator arm. With the advance of reliable,  
positive locking quick attachment brackets, it has  
become desirable to use a quick attachment arrangement  
for earth augers, compactors, clam shells and other  
powered implements as well.

### 30 SUMMARY OF THE INVENTION

The present invention relates to a mounting  
device for a powered auxiliary tool used with a boom or  
arm of a backhoe or excavator, which permits the power

-2-

unit such as a motor to be mounted onto a quick attachment bracket usable with a frame that permits quick attachment to a boom or arm and which are also used with attachments for other types of tools, such as digging buckets or the like. The present attachment includes a pivot frame carried by a quick attachment frame that will latch onto a quick attachment bracket, and be locked in place. The pivot frame provides a pivotal mounting for a motor or power unit, as shown an earth auger and when mounted on the quick attachment frame permits a limited amount of pivoting about a first horizontal axis, (one degree of freedom) so that the auger axis can be permitted to seek vertical under gravity. The quick attachment frame has pivot stops to permit control so that the auger pivoting may be stopped at a desired angle relative to the vertical and can be further pivoted under power by pivoting the quick attachment bracket when the quick attachment frame is latched in place when not in use.

20           The pivot frame has corners which will engage stops on portions of the quick attachment frame after a desired number of degrees of pivoting, so that a positive contact is made with the quick attachment frame. The quick attachment bracket is a universal bracket pivoted to a backhoe or excavator arm and controlled for pivoting by an actuator, to in turn move the auger about the mounting axis of the quick attachment bracket after the pivot frame and driven tool (the auger) has pivoted to the stopped position.

30           The auger can be permitted to accommodate variations in working conditions that require limited pivoting about a first horizontal mounting axis, while taking advantage of a quick attachment bracket for connection to an implement.

-3-

The implement operator thus has the ability to control the inclination of the power unit and mounted auger about one horizontal axis when the pivot frame engages the stops. The auger can then be placed into a storage position folded underneath the arm as shown in dotted lines in Figure 1, lowered to and rested on the ground or a support and unlatched from or latched to the quick attachment bracket.

#### BRIEF DESCRIPTION OF THE DRAWINGS

Figure 1 is a schematic representation of a backhoe or excavator arm having a bracket made according to the present invention installed thereon and holding a schematically shown power unit and tool comprising an earth auger in position;

Figure 2 is an enlarged fragmentary view with parts in section and parts broken away showing details of a quick attachment bracket and a mounting frame for the auger in a position prior to latching;

Figure 3 is a sectional view showing a mounting frame and quick attachment bracket in a latched position;

Figure 4 is a perspective view of the mounting frame detached from its supports on a backhoe or excavator arm;

Figure 5 is a side elevational view illustrating an attachment bracket and mounting frame for an auger with parts in section and broken away; and

Figure 6 is a view taken generally along line 6--6 in Figure 5.

#### DETAILED DESCRIPTION OF THE PREFERRED EMBODIMENTS

A powered implement arm 10 such as on an excavator or backhoe is used to mount a powered auxiliary tool, as shown an auger assembly 11. The arm 10 is pivotally mounted to a boom arm section 13 at

-4-

pivot 12 (Figure 1). The boom arm 13 is pivoted to a backhoe or excavator represented at 13A. The arm 10 is controlled and operated from the implement mounting platform, using hydraulic actuators from a source of hydraulic fluid under pressure, and operated by valve controls 14. An outer end of the arm 10 as shown mounts a link assembly 18 that is used for controlling pivoting of the tool or auger assembly 11 relative to the arm 10. The link assembly 18 is actuated with a double acting hydraulic actuator shown at 22 and operated through valve 14. The actuator 22 extends and retracts an actuator rod 22A under power and controls pivotal movement of a quick attachment mounting bracket 24 that is pivotally mounted on a pin 26 to the outer end of the arm 10. The actuator 22, acting through link assembly 18 will control pivoting of the bracket 24 about the horizontal axis of the pin 26. The hydraulic actuator can be attached directly to the bracket 24 to eliminate the link assembly 18, if desired.

The link assembly 18 as shown, has a pair of links 19A and 19B that are pivotally mounted together with a pin 19C. The pin 19C also is the attachment pin for the actuator rod 22A. The links 19A and 19B are suitably bifurcated to permit attachment on the single pin 19C. The link 19A is pivotally mounted to the arm 10 with the pin 19D and the outer end of link 19B is pivotally mounted to quick attachment bracket 24 with a pin 28.

The quick attachment bracket 24 as seen in Figures 2 and 3 and 4 has a pair of side plates 30, 30 that support a formed bar 32 that extends across the space between the side plates 30 and is welded to the side plates 30 to form an assembly. The side plates 30 are formed to have lower support ears 36 that are

-5-

recessed to support a "C" shaped saddle or retainer 40 that also extends across the space between the side plates 30 and is welded thereto to secure the opposite ends of the quick attachment bracket 24. A tongue 40C  
5 of the saddle extends between the side plates. The side plates 30 receive the main mounting pin 26 through bores 26A and the pin 26 extends across the space between the side plates 30. The linkage pin 28 also extends through bores 28A and extends across the space between the side  
10 plates 30.

A pin 38 is supported on the outer ends of the ears 36 and is held in place partially under a lead-in lip 40A on one outer edge of the "C" shaped saddle 40. The pin 38 extends outwardly beyond the side plates 30  
15 to provide support ends 38A, which are used to support the auger assembly 11 during mounting and releasing an adapter or mounting frame 20 from the quick attachment bracket 24.

The pivot pin 28, as shown for automatic  
20 operation also mounts a frame latch 41 (Figures 2 and 3). The latch 41 is a yoke shaped member that has a pair of latch arms 42 held together with a latch bar 43 at their outer ends. The arms 42 have hubs 44 that also have bores that pivotally mount over the pivot pin 28.  
25 The hubs 44 have control arms 45 extending therefrom, and the arms 45 are spring loaded with strong compression springs 46 that are retained in spring supports 47 that are fixed to the side plates 30 and bear against the arms 45. The end 43A of the latch 41  
30 is rounded with a large radius for smooth engagement when latching.

The latch 41 is thus urged by the springs 46 to rotate in counterclockwise direction as shown in

-6-

Figures 2 and 3, and the latch 41 is retained from rotating beyond a desired position.

The adapter frame 20 includes a quick attachment frame 48 which is used to couple to quick attachment bracket 24 shown in Figures 1, 2, 3, 5 and 6. The frame 48 is made up of side plates 50, 50 that are welded to a latch backing plate 52 that is mounted to a plate 49 to make a plate assembly 55. The side plates 50 have hook ends 54 with receptacles 56 formed in them.

The side plates 50 of the frame 48 are spaced wider than the side plates 30, the bar 32 and the "C" shaped saddle 40 of bracket 24. The side plates 50 thus will fit over the outside of the quick attachment bracket 24 when the bracket 24 seats in the quick attachment frame 48.

The latch 41 is held in its "ready" position shown in Figure 2 when the quick attach bracket 24 is ready to be used in any selected way, and as shown in Figures 2 and 3, a pivoting pawl 58 is mounted on a shaft 57, on at least one side of the latch. The pivoting pawl 58 aligns with a hub 44 of the frame latch 41 and as shown in Figure 3 the pawl 58 is positioned to engage a stop lug 59 integral with a hub 44. The stop lug has a stop surface 59A for holding the latch retracted when the frame is to be released. Block or actuator 84 and a surface of arm 45 are used to hold the latch in the ready position as shown in Figure 2. The pawl 58 is spring loaded with a torsion spring 58A to rotate in clockwise direction as shown in Figure 3. The torsion spring 58A is shown only schematically. The pawl 58 is optional, in that the latch 41 can be held by actuator 84, which will be explained subsequently. The end of the latch 41 protrudes into the area overlying

-7-

the "C" shaped saddle 40 when the latch is in its ready position as shown in Figure 2.

The plate 52 of frame 48 in the form shown, is formed to mate with and be retained by the quick attachment bracket 24 and is perhaps best understood from the showing in Figures 2 and 3 includes a planar flange portion 52A at one end. In the mid portions of the plate 52 it bends inwardly through an opening 49A in a plate 49 that forms part of an auger mounting adapter 20 to a secure mounting plate for spaced supports 51 that mount a pivot hub 53 (See Figures 2, 3, 5 and 6). An inclined latch wall section 52B of plate 52 is formed to extend back outwardly through opening 49A. The plate 52 has a section 52F that is coplanar with planar flange portion 52A and the end of the plate 52 then has a flange 52C formed at an angle, as shown at right angles, to the plane of the planar flange portion 52A and the wall section 52F. The flange 52C has a rounded corner and is made to seat in the receptacle formed in the ears 54 of the side plates 50 of the quick attachment frame 48.

The plate 49 is formed with an inverted channel edge portion 49B, as perhaps can be seen by referring to Figure 3. The channel 49B is formed with a base wall 49C and a flange 49D is formed to extend back toward the opposite end of the plate 49. The opening 49A formed in the plate 49 permits the latch section 52B of plate 52 to extend to position to be engaged by latch 41 when the frame 48 is attached to the mounting bracket 24.

The frame 48 can also be retained in position with bolts that extend from the frame 48 to the bracket 24 to hold the frame 48 in place.

-8-

The adapter frame 20 further includes a pivot frame or hanger bracket 60 that as shown has a pair of side plates 60A and 60B that are spaced apart at one end and have pivot hubs 60C therein, which fit to the outside of the hub 53, and a pivot pin 61 is used for pivotally mounting the pivot frame 60 to the attachment frame section 48. Additionally, the side plates 60A and 60B taper together at the lower end. The side plates are held with a pair of suitable spaced brace plates 60D. The lower ends of plates 60A and 60B mount a sleeve 62 which is positioned with its axis at 90° to the axis of the pivot pin 61. The sleeve 62 in turn carries a pivot pin 63 which passes through support ears 64 on a hydraulic motor or power unit frame assembly 65 that mounts a motor or power unit 65A shown schematically and forming the drive for the earth auger or for other tools. The motor frame assembly 65, as shown in Figure 1 mounts a hydraulic motor 65A that has an output shaft that directly drives a helical auger 66, that is used for drilling into the ground. The motor 65A is a power unit and can be used for powering other accessories such as a compactor plate or the like. Also, the motor can be mounted directly to the pivot frame 60, between side plates 60A and 60B.

The side plates 60A and 60B are formed relative to the surface of latch backing plate 52 that is adjacent to the plates 60A and 60B so that the pivot frame 60 can swing relative to the attachment bracket 48 for alignment purposes when initially working, but can be also controlled by an operator actuating the actuator 22. As shown, the end edges of each of the plates 60A and 60B adjacent the side that is near the latch backing plate 52 have a trimmed surface 67 that is formed to be at a selected angle relative to the plane of the bent

-9-

out portion 52H of backing plate 52 so it will stop  
against the portion 52H of backing plate 52 which is  
part of a plate assembly 55, when the bracket 48 is  
rotated counter clockwise in Figures 2 and 5 a selected  
5 amount with the attachment frame latched to quick attach  
bracket 24. It should be noted that in Figure 2 the  
attachment frame 48 is shown in the progress of being  
attached to bracket 24. The edges of plates 60A and 60B  
on an opposite side from edge 67 are formed as shown at  
10 68. The edges 67 and 68 are at angles selected so that  
the pivot frame 60 will be stopped on the desired  
position in the opposite direction of pivoting against  
the planar part of the plate 49, which is part of a  
plate assembly 55 with plate 52. The stop action is  
15 against either plate of the plate assembly, which can be  
considered a single plate for this purpose. If the  
latch portion 52H is not used, edge 67 can be stopped on  
part of plate 49.

The portion of the side plates 60A and 60B  
20 between the edges 67 and 68 is trimmed away so that the  
auger pivot frame can pivot on the pin 53 a selected  
number of degrees in either direction of pivoting. As  
shown in Figure 1, the pivoting in counter clockwise  
direction relative to the quick attach frame with the  
25 bracket 24 positioned as shown will be about  $110^\circ$ , and  
when the actuator 22 is fully retracted, the axis of the  
auger will be approximately  $5^\circ$  from vertical in a  
counter clockwise direction.

To fold the auger assembly underneath the  
30 boom, the actuator 22 is fully extended, to move the  
auger assembly to position also shown in dotted lines in  
Figure 1, but it also shows that the auger or other tool  
then can be above a horizontal plane.

-10-

In the working position, in between the extremes, the auger or tool will float or be free to pivot about the pivot frame mounting axis and will seek a vertical position, as a pendulum. The pivoting can  
5 continue until one of the stop edges 67 and 68 engage the aligned stop formed by the plates 49 and 52.

The auger can pivot from side to side about the axis of the pin 63, as permitted by a stop bracket 64A mounted on one of the ears 64. The stop bracket has  
10 ears 64B that will engage an end of a pin 60E held in brace plates 60D to limit the pivoting of the auger. The stops formed by the quick attach frame plate section 52A cooperating with the pivot bracket 60 permit the operator to control positioning of the auger while  
15 permitting the auger to be aligned under gravity.

The quick attachment frame 48 can easily be installed on the quick attachment bracket 24 on the arm  
10 using a procedure shown schematically in Figures 2 and 3. When the auger is to be attached to the arm 10,  
20 the receptacles 56 of side plates 50 are hooked onto the ends 38A of the rod 38, with the auger in an appropriate stored position. The auger or tool can be stored either to be in a substantially horizontal position, or supported in a vertical rack. Moving the arm 10 to the  
25 desired location and extending the actuator 22 will roll the quick attachment bracket 24 so that the nose bar 32 fits between the side plates 50, 50 and edges 32A can be rested against the plate portion 52A, both of which positions are shown in Figure 2. The flange 52C and the  
30 channel member 49B can then be slipped into the "C" shaped saddle 40 receptacle by moving the arm 10 about pivot 12.

The side plates 50 have ears 70 that protrude from the plate 52, and are spaced apart. These ears 70

-11-

have slots that receive a cross retainer bar 72, that is thus spaced from the parallel plate portion 52A to form a receiver slot 73 for the nose bar 32. Upon sliding the quick attachment bracket 24 into position, the nose bar 32 will pass between the bar 72 and the plate portion 52A as the channel section and flange 52C seat in the receptacle on the quick attachment bracket. The latch 41, and in particular the nose portions 42 and the cross member 43, will slide out of the way as the quick attachment frame 48 is pushed into position. The latch 41 will spring back to cause the end 43A to rest against the inclined latch section 52B of plate 52 and hold the quick attachment frame 48 securely on the quick attachment bracket 24, to latch the entire auger adapter 20 in place. Again, the nose bar 32 can be attached to a cross member supported on ears 70 with bolts if the automatic latch is not used.

The latch 41 can be released for disconnecting frame 48 by actuating suitable actuators 84 that are mounted on brackets 86 on the side plates 30. The actuators 84 have rods 85 that act on the arms 45 and retract the latch 41 to clear the plate 52 and permit the quick attachment frame 48 to be released from the quick attachment bracket 24. Stop dog 58 will seat on the surface 59A to hold the latch 41 in its released position after the quick attachment frame 48 has been removed. The latch dog 58 is spring loaded with a torsion spring toward the surface 59A. A pry bar or lever can be used in recess 80 for unlatching the latch 44, for manual operation.

The earth auger 11 or other tool thus can be quickly attached to a backhoe or excavator arm, and can be provided with the freedom about one axis to swing relative to the adapter bracket that has stop surfaces

-12-

for limiting the amount of swing but permitting  
sufficient swing for operation. The hydraulic motor 65A  
supported on frame assembly 65 for the auger is powered  
in the normal manner from the power unit for the backhoe  
5 or excavator. Other tools can be attached to the motor  
and will have the freedom to pivot about the axis of  
pivot pin 61 until it strikes the stop edges.

Although the present invention has been  
described with reference to preferred embodiments,  
10 workers skilled in the art will recognize that changes  
may be made in form and detail without departing from  
the spirit and scope of the invention.

**THE EMBODIMENTS OF THE INVENTION IN WHICH AN EXCLUSIVE PROPERTY OR PRIVILEGE IS CLAIMED ARE DEFINED AS FOLLOWS:**

1. A mounting device for mounting a powered attachment tool to a quick attachment bracket that is pivotally mounted on a prime mover, the quick attachment bracket comprising a receptacle, and a mounting member spaced from the receptacle, the mounting device comprising an adapter frame, including a plate assembly having an edge portion for mating with the receptacle on the bracket and a receiver spaced from the edge portion for receiving the mounting member of the bracket, at least one support plate mounted on said adapter frame, a hub supported on the at least one support plate and having an axis parallel to a selected pivotal axis of the quick attachment bracket on which the adapter frame is placed, a hanger bracket for the powered attachment tool pivotally mounted on said hub, said hanger bracket having edges adjacent portions of said adapter frame formed to provide for a limited amount of pivoting of the hanger bracket relative to the adapter frame before the edges engage the adapter frame.

2. The device of claim 1, wherein said adapter frame has a wall portion, one of said hanger plate edges engaging the wall portion in one direction of pivoting of the hanger.

3. The device of claim 1, wherein said hanger comprises a second hub mounted with an axis perpendicular to the axis of the first hub, said second hub pivotally mounting the powered tool such that the powered tool can pivot relative to the adapter frame about two substantially mutually perpendicular axes.

4. The device of claim 1, wherein said quick attachment bracket is pivotally mounted to a support arm of the prime mover, a hydraulic actuator for pivotally moving said quick attachment bracket, said hydraulic

actuator having a range of linear movement, said bracket being pivotable more than 90° by moving the actuator through its range of movement.

5. The device of claim 2, wherein a second edge of the hanger bracket on an opposite side of the hub from the first edge engages and stops against a portion of the plate assembly in a second direction of pivoting.

6. The device of claim 3, wherein the hanger bracket comprises first and second hanger plates on opposite ends of the hub, the second hub being supported by both of said hanger plates.

7. The device of claim 1, wherein the hanger has end edges adjacent the adapter frame when supported on the hub, the end edges being trimmed at selected angles to provide clearance for permitting the limited amount of pivoting.

8. The device of claim 1, wherein the adapter frame includes a base wall extending between the edge portion and the receiver, the support plate being mounted on the base wall, and wherein the hanger bracket comprises a pair of spaced apart hanger plates, the hub extending between the hanger plates at one end thereof, the hanger plates having planes parallel to the support plate, the hanger plates having edges at the ends thereof including corner portions trimmed to provide stop surfaces engaging portions of the

base wall at selected positions of pivoting.

9. A mounting device for mounting a powered tool to a quick attachment bracket that is pivotally mounted on a prime mover, the quick attachment bracket comprising a receptacle, and a mounting member spaced from the receptacle, the mounting device comprising an adapter frame, including an assembly having a pair of side plates and a cross plate between the side plates,

an edge mounting member extending between the side plates for mating with the receptacle on the bracket, and a receiver slot between the side plates for receiving and retaining the mounting member of the bracket, at a location spaced from the edge member when the adapter frame is positioned on the bracket, a hub supported on and extending between the side plates at a position spaced from the cross plate and from the edge member, the hub having an axis substantially parallel to the cross plate, a hanger bracket for the power unit pivotally mounted on said hub between planes of the side plates, said hanger bracket having hanger bracket plates with end edges adjacent portions of said cross plate, the end edges being formed to provide stops that stop against the cross plate to limit the pivoting of the hanger bracket relative to the adapter frame about the axis of the hub.

10. The mounting device of claim 9, in combination with a quick attachment bracket adapted to be pivotally mounted to a support arm of a prime mover, a hydraulic actuator for pivotally moving said quick attachment bracket, said hydraulic actuator having a range of linear movement, said bracket being pivotable more than 90° by moving the actuator through its range of movement.

11. The mounting device of claim 9, wherein the end edges of the hanger bracket plates are adjacent the cross plate when the hanger bracket is supported on the hub, the end edges being trimmed at selected angles on opposite sides of each hanger bracket plate.

12. The mounting device of claim 11, wherein the cross plate comprises a plate assembly including a latch plate portion formed to provide a latch surface for engaging a latch on the quick attachment bracket.

□ FILENAME \p :::ODMA\PCDOCS\CCT\523280\1:::ODMA\PCDOCS\CCT\523184\1□



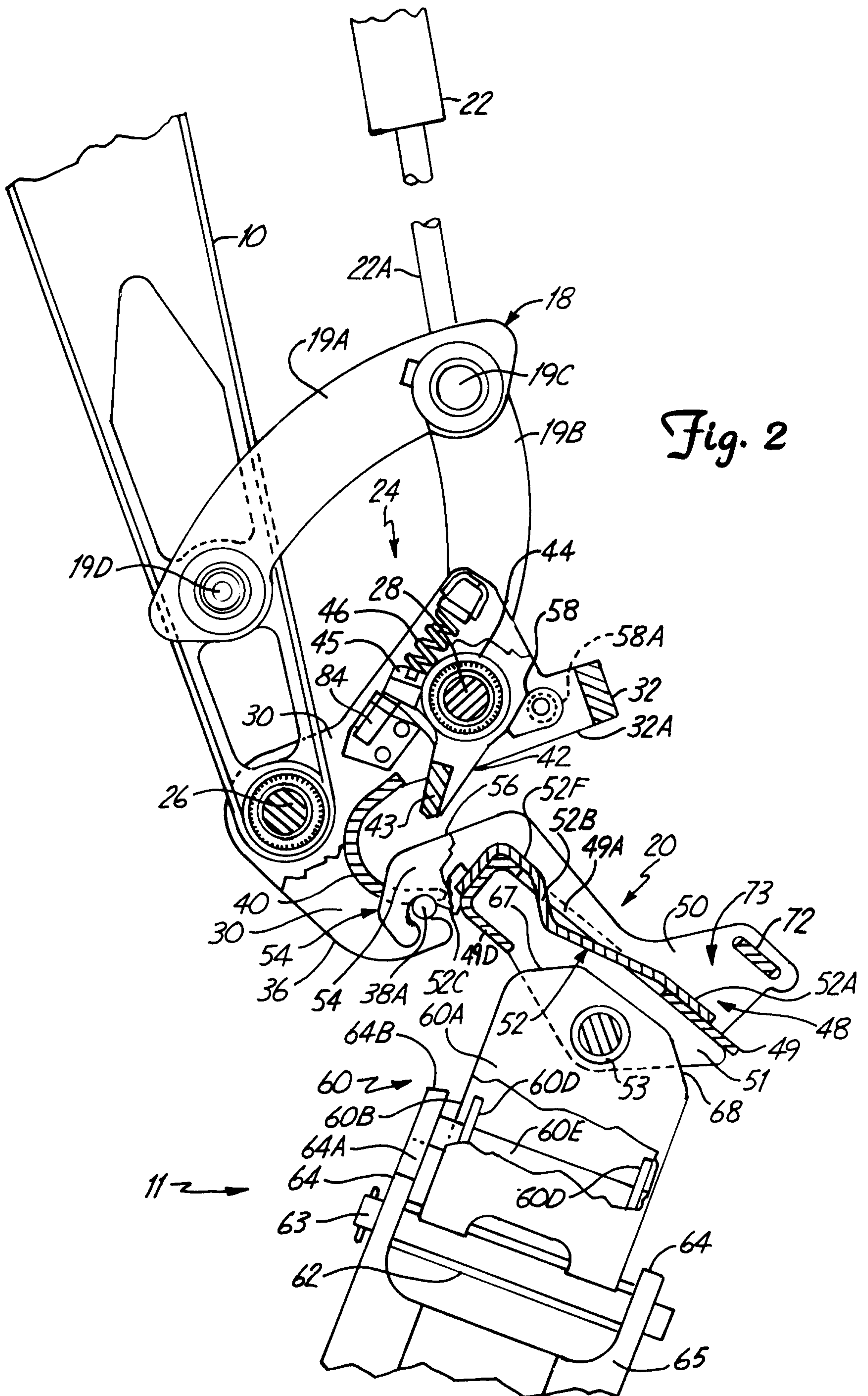

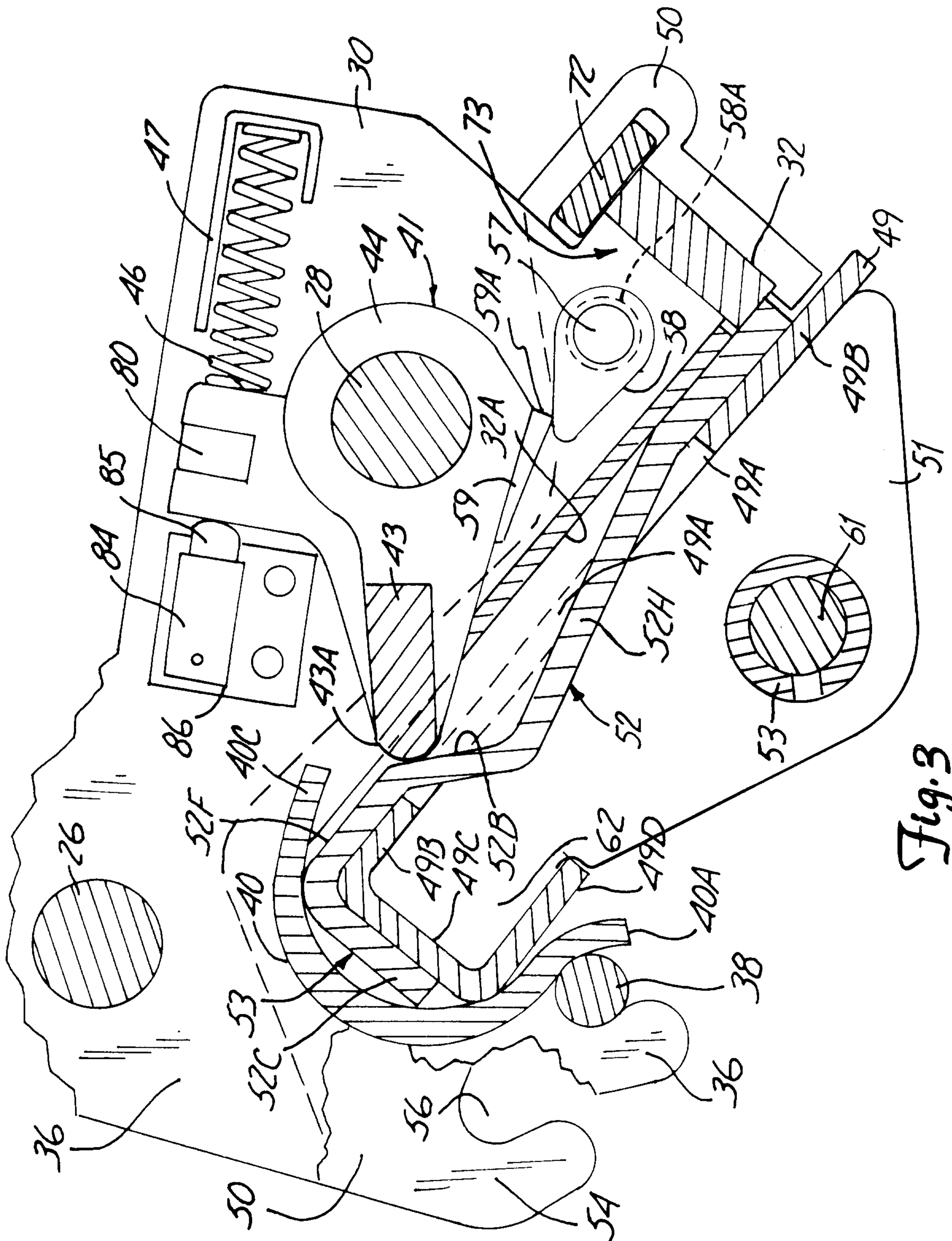

Fig. 3

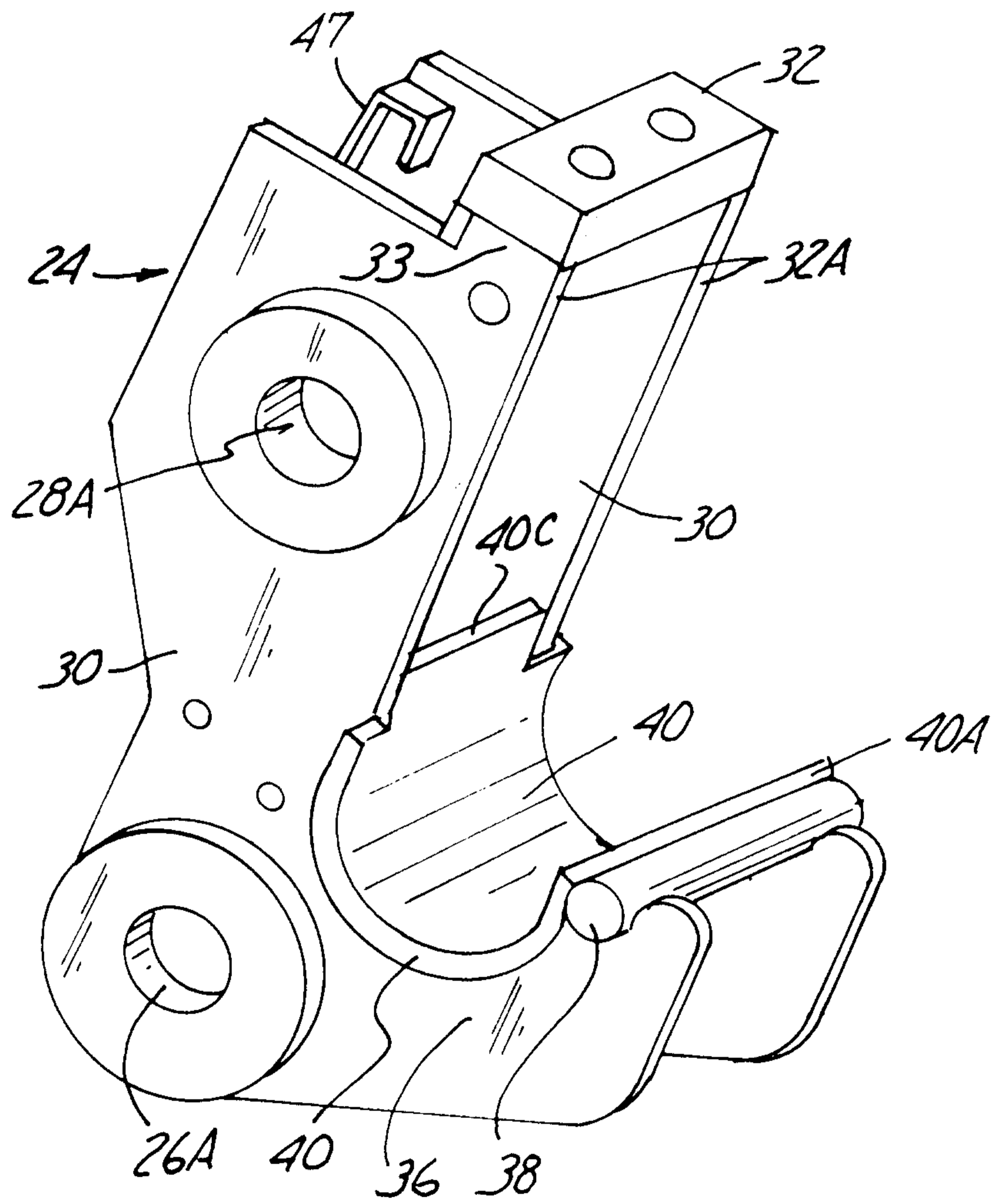

Fig. 4



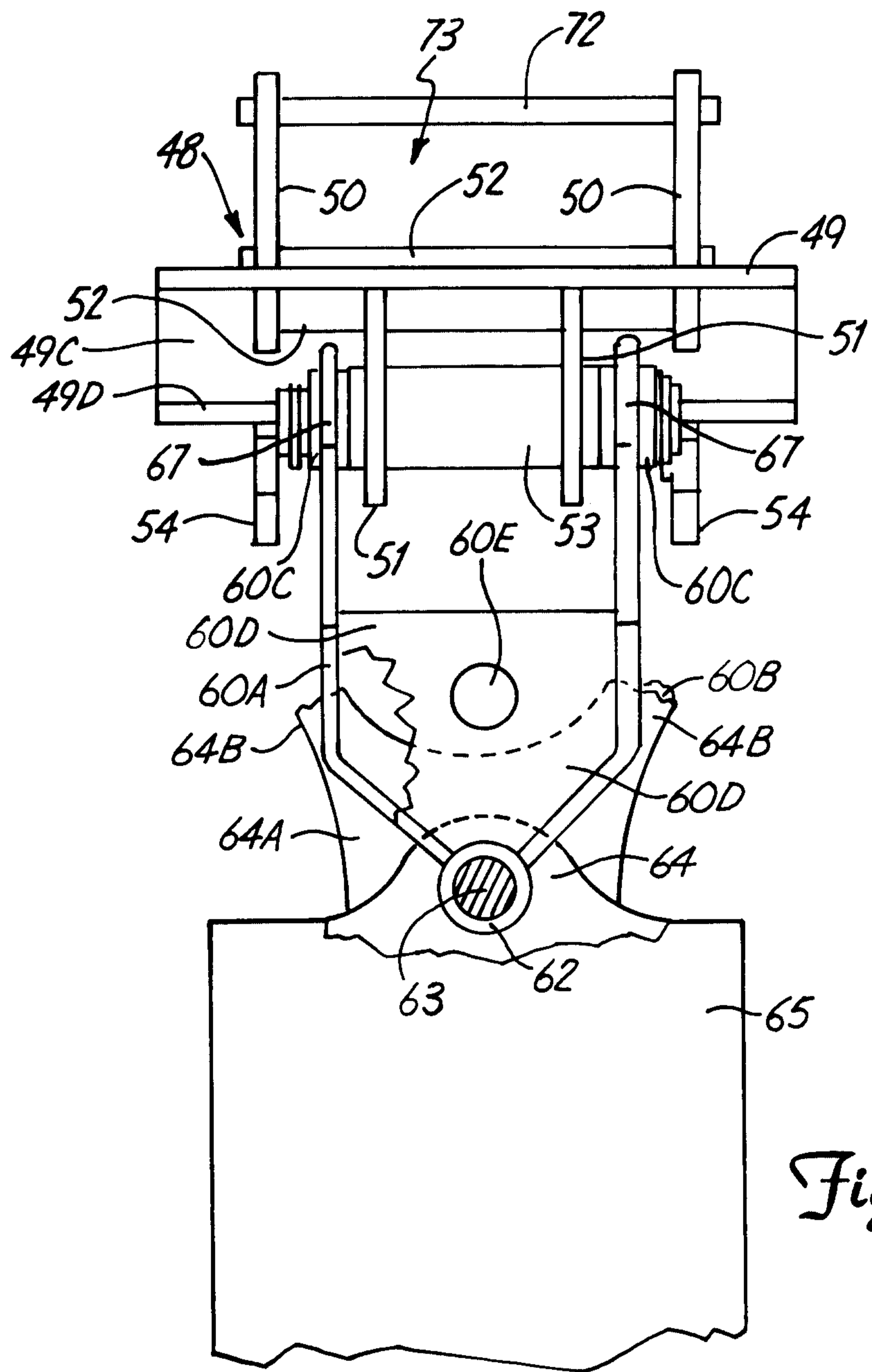

Fig. 6

