

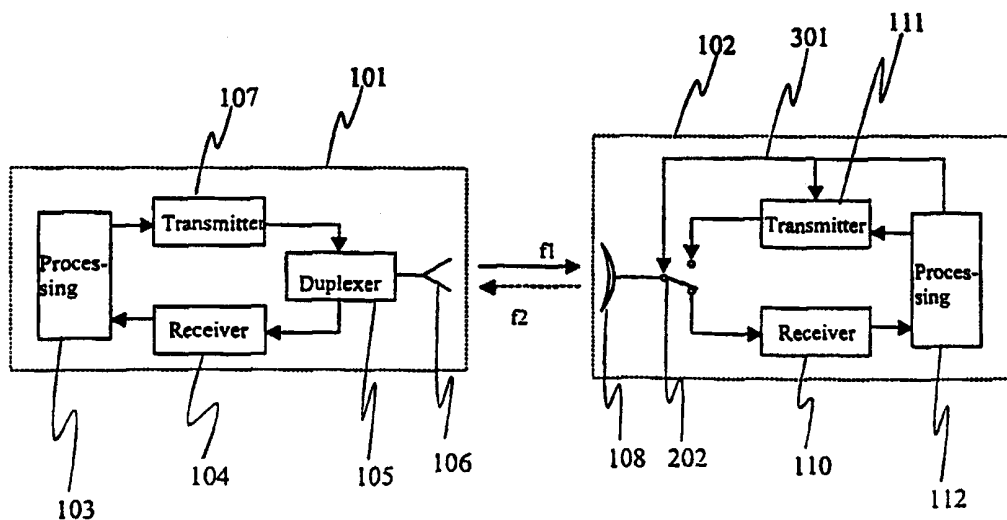

INTERNATIONAL APPLICATION PUBLISHED UNDER THE PATENT COOPERATION TREATY (PCT)

<p>(51) International Patent Classification ⁷ : H04B 7/24, H04Q 7/20</p>	<p>A1</p>	<p>(11) International Publication Number: WO 00/54434 (43) International Publication Date: 14 September 2000 (14.09.00)</p>
<p>(21) International Application Number: PCT/FI00/00174 (22) International Filing Date: 6 March 2000 (06.03.00) (30) Priority Data: 990483 5 March 1999 (05.03.99) FI (71) Applicant (for all designated States except US): NOKIA NETWORKS OY [FI/FI]; P.O. Box 300, FIN-00045 Nokia Group (FI). (72) Inventor; and (75) Inventor/Applicant (for US only): MÄKINEN, Jarmo [FI/FI]; Vahverotie 5 D, FIN-02730 Espoo (FI). (74) Agent: BERGGREN OY AB; P.O. Box 16, FIN-00101 Helsinki (FI).</p>	<p>(81) Designated States: AE, AL, AM, AT, AU, AZ, BA, BB, BG, BR, BY, CA, CH, CN, CR, CU, CZ, DE, DK, DM, EE, ES, FI, GB, GD, GE, GH, GM, HR, HU, ID, IL, IN, IS, JP, KE, KG, KP, KR, KZ, LC, LK, LR, LS, LT, LU, LV, MA, MD, MG, MK, MN, MW, MX, NO, NZ, PL, PT, RO, RU, SD, SE, SG, SI, SK, SL, TJ, TM, TR, TT, TZ, UA, UG, US, UZ, VN, YU, ZA, ZW, ARIPO patent (GH, GM, KE, LS, MW, SD, SL, SZ, TZ, UG, ZW), Eurasian patent (AM, AZ, BY, KG, KZ, MD, RU, TJ, TM), European patent (AT, BE, CH, CY, DE, DK, ES, FI, FR, GB, GR, IE, IT, LU, MC, NL, PT, SE), OAPI patent (BF, BJ, CF, CG, CI, CM, GA, GN, GW, ML, MR, NE, SN, TD, TG).</p> <p>Published <i>With international search report.</i> <i>Before the expiration of the time limit for amending the claims and to be republished in the event of the receipt of amendments.</i> <i>In English translation (filed in Finnish).</i></p>	

(54) Title: DATA TRANSMISSION METHOD AND RADIO LINK SYSTEM



(57) Abstract

This invention relates to data transmission in a microwave link system particularly through point-to-multipoint connections. The arrangement according to the invention utilizes both frequency and time division duplex arrangement to simplify substation structures. In accordance with the invention a substation transmits at different times than it receives, and uses different frequencies for the transmission and reception. The central station, in turn, includes a duplexer unit, whereby it can both transmit and receive simultaneously when the transmission and reception frequencies are sufficiently apart. Such an arrangement achieves advantages of the time division duplex arrangement, such as e.g. an inexpensive substation structure, without the drawbacks related to the time division duplex arrangement.

FOR THE PURPOSES OF INFORMATION ONLY

Codes used to identify States party to the PCT on the front pages of pamphlets publishing international applications under the PCT.

AL	Albania	ES	Spain	LS	Lesotho	SI	Slovenia
AM	Armenia	FI	Finland	LT	Lithuania	SK	Slovakia
AT	Austria	FR	France	LU	Luxembourg	SN	Senegal
AU	Australia	GA	Gabon	LV	Latvia	SZ	Swaziland
AZ	Azerbaijan	GB	United Kingdom	MC	Monaco	TD	Chad
BA	Bosnia and Herzegovina	GE	Georgia	MD	Republic of Moldova	TG	Togo
BB	Barbados	GH	Ghana	MG	Madagascar	TJ	Tajikistan
BE	Belgium	GN	Guinea	MK	The former Yugoslav Republic of Macedonia	TM	Turkmenistan
BF	Burkina Faso	GR	Greece	ML	Mali	TR	Turkey
BG	Bulgaria	HU	Hungary	MN	Mongolia	TT	Trinidad and Tobago
BJ	Benin	IE	Ireland	MR	Mauritania	UA	Ukraine
BR	Brazil	IL	Israel	MW	Malawi	UG	Uganda
BY	Belarus	IS	Iceland	MX	Mexico	US	United States of America
CA	Canada	IT	Italy	NE	Niger	UZ	Uzbekistan
CF	Central African Republic	JP	Japan	NL	Netherlands	VN	Viet Nam
CG	Congo	KE	Kenya	NO	Norway	YU	Yugoslavia
CH	Switzerland	KG	Kyrgyzstan	NZ	New Zealand	ZW	Zimbabwe
CI	Côte d'Ivoire	KP	Democratic People's Republic of Korea	PL	Poland		
CM	Cameroon	KR	Republic of Korea	PT	Portugal		
CN	China	KZ	Kazakistan	RO	Romania		
CU	Cuba	LC	Saint Lucia	RU	Russian Federation		
CZ	Czech Republic	LI	Liechtenstein	SD	Sudan		
DE	Germany	LK	Sri Lanka	SE	Sweden		
DK	Denmark	LR	Liberia	SG	Singapore		
EE	Estonia						

Data transmission method and radio link system

This invention relates to data transmission in a microwave link system especially through point-to-multipoint connections.

5 In this context "point-to-multipoint" (PMP) refers to an arrangement where a central station is connected with a plurality of substations. Such an arrangement is used e.g. to connect base stations of mobile communication systems to a mobile communication network whereby several base stations serving mobile stations have a point-to-multipoint connection with a central station serving several base stations. In such an
10 arrangement there is no need to arrange fixed signal wiring to every base station, which is a big advantage particularly in urban environment where there is a dense arrangement of base stations and where the installation of cables is laborious and expensive.

Point-to-multipoint systems usually employ a so-called frequency division duplex
15 (FDD) arrangement, in which the uplink and downlink signals are transmitted at different frequencies so that the signals of different directions can be discriminated by frequency.

Point-to-multipoint systems use a time division duplex (TDD) system as well. In a
20 time division duplex system the central station and substation share a common traffic channel used at different times by the central station and substation(s).

Arrangements in which a plurality of transmitting parties transmit signals on the
same channel in such a manner that the signals are discriminated by the moment of
transmission, are generally called time division multiple access (TDMA) arrange-
ments. Arrangements typically used in point-to-multipoint connections are thus
25 TDMA arrangements in uplink communications. So, the frequency division duplex arrangement described above may be called a FDD TDMA arrangement because in it the uplink and downlink signals are discriminated by frequency but the uplink signals are discriminated by time. Similarly, the time division duplex PMP arrangement described above may be called a TDD TDMA arrangement.

30 Other types of multiple access arrangements are known as well. In a frequency division multiple access (FDMA) arrangement, for instance, signals on the same signal path are discriminated by frequency. Applied to the one central station and a plurality of substations example described above a FDMA arrangement would mean that

the substations transmit to the central station at their particular frequencies whereby the central station could discriminate the signals of the different substations by their transmission frequencies. In a code division multiple access (CDMA) arrangement the signals on the same signal path are discriminated on the basis of spreading codes.

Fig. 1 shows a prior-art frequency division duplex arrangement for discriminating between the uplink and downlink directions in point-to-multipoint connections. A central station 101 comprises a baseband processing unit 103. A transmitter unit 107 and receiver unit 104 take care of functions related to the transmission and reception of signals. A duplexer unit 105 couples both the transmitter unit 107 and the receiver unit 104 to an antenna so that they can transmit or receive signals through a single antenna 106. The coupling is such that at a particular frequency the duplexer unit 105 couples the transmitter unit 111 to the antenna 106 and at a second particular frequency the duplexer unit 105 couples the receiver unit 104 to the antenna 106. The duplexer unit is usually realized by means of filters. Correspondingly, a substation 102 is arranged so as to comprise the corresponding units for receiving and transmitting signals. The substation 102 includes an antenna 108, duplexer unit 109, transmitter unit 111, receiver unit 110 and a processing unit 112. In the arrangement according to Fig. 1 the central station 101 and substation 102 use two different frequencies f_1 ; f_2 to transmit signals. All substations 102 communicating with one and the same central station 101 use substantially the same transmission frequency to communicate with the central station 101. In addition, the substation 102 comprises an arrangement with which the processing unit 112 controls 113 the transmission of the transmitter unit 111.

Fig. 2 shows a prior-art time division duplex arrangement for transmitting data in point-to-multipoint connections. A central station 101 comprises a processing unit 103, transmitter unit 107, receiver unit 104 and an antenna 106. Additionally in a time division duplex system there is between the antenna 106 and transmitter unit 107 as well as receiver unit 104 a switch element 201 to control the transmission and reception of signals. In the central station 101 the processing unit 103 is arranged so as to control 203 the operation of the transmitter unit 107 and the switch element 201. A prior-art substation 102 in a time division duplex system comprises an antenna 108, switch element 202, transmitter unit 111, receiver unit 110 and a processing unit 112. The processing unit 112 controls 204 the receiver unit 110 and switch element 202 in the substation 102 so that transmission occurs in the right time slot. When using the time division duplex arrangement, only one frequency is

needed to convey the data since the transmission and reception are arranged so as to take place in different time slots.

Arrangements in accordance with Figs. 1 and 2 are used at microwave frequencies such as 2 GHz and higher. Such prior-art arrangements are used at frequencies of up to several tens of GHz.

Both the frequency division duplex and the time division duplex system have drawbacks in point-to-multipoint systems implemented in the microwave region. The biggest disadvantage of the frequency division duplex system is that it requires filters, which are expensive components. In the microwave region, signal conductors, i.e. waveguides and filters, are relatively large mechanical structures that have to be machined at very small tolerances. The pass bands of filters must be made quite narrow so that the transition from the pass band to the stop band be steep enough. Moreover, the gap between the frequency bands of the uplink and downlink directions is typically quite narrow, which adds to the steepness required of the filter. Therefore, the pass band of a steep enough filter typically does not suffice to cover the whole frequency band used by the system. Thus, in order to cover the various sub-bands the radio apparatuses of radio link systems must be implemented in several different versions. So, versions are installed for the central and substations according to the operating frequency. Especially it may be required that several parallel transceiver units adapted to the different sub-bands be installed at the central stations in accordance with the operating frequencies used.

This kind of an arrangement is naturally very expensive. The continual expansion of broadband data transmission and mobile communication systems adds to the need for microwave links, too, whereby it is obvious that simpler and less expensive solutions are needed to realize point-to-multipoint connections. In this patent application microwave frequencies refer to in this patent application 2 GHz and higher frequencies.

Use of expensive filters can be avoided by means of the time division duplex arrangement mentioned above. However, compared to the frequency division duplex arrangement the time division duplex arrangement has its own disadvantages. Compared to a solution based on separate transmission and reception frequencies a time division duplex system achieves only half of the transmission rate of the frequency division duplex system, as the time has to be divided between transmission and reception. This disadvantage can be alleviated by using higher data rates but this, in turn, makes the apparatuses more complex since the clock fre-

quency of the data transmission elements must be increased. Furthermore, a time division duplex system is problematic in the rather usual case where the area managed by one central station is divided into separate sectors. In that case the central station will have one transceiver apparatus for each sector. This being the
5 case, the transmission and reception periods of the different sectors have to be synchronized or the frequencies have to be chosen such that they are sufficiently apart so that a transmission of an adjacent sector will not disturb the reception of another sector at the central station. Because of the short distance between the transmitters and receivers of the different sectors at the central station the disturbance caused by
10 a transmission in the non-synchronized case is very powerful unless the transmission and reception frequencies are significantly different. Moreover, time division duplex transmission is not allowed in all frequency ranges.

An object of this invention is to eliminate the prior-art problems described above. Another object of this invention is to provide a radio link system cheaper and
15 simpler than prior-art solutions.

These objects are reached by arranging the central station so as to transmit a TDM signal, i.e. a multiplexed signal, at a first frequency and to receive signals from substations at a second frequency, and by arranging each substation so as to operate on a time and frequency division basis, i.e. to receive during certain first periods at said
20 first frequency and to transmit during certain second periods, which are separate from said first periods, at said second frequency.

A data transmission system according to the invention is characterized by what is specified in the characterizing part of the independent method claim. A radio link system according to the invention is characterized by what is specified in the characterizing part of the independent radio link system claim. Subclaims describe
25 different advantageous embodiments of the invention.

An arrangement according to the invention uses both a frequency division duplex and time division duplex arrangement to simplify the substation structures. In accordance with the invention, a substation transmits at a different time than it
30 receives, and uses different frequencies for the transmission and reception. The central station, in turn, includes a duplexer unit so it can both transmit and receive simultaneously when the transmission and reception frequencies are separate enough. Such an arrangement has the advantages of the time division duplex arrangement, such as e.g. inexpensive substation structure, without the disadvantages of the time division duplex arrangement.
35

In the following, the invention is described referring to the attached drawings, where

Fig. 1 shows a prior-art arrangement,

Fig. 2 shows a second prior-art arrangement,

5 Fig. 3 shows a solution according to the invention,

Fig. 4 shows a network arrangement according to the invention, and

Fig. 5 shows a time slot arrangement in a solution according to the invention.

Figs. 1 and 2 were discussed above in connection with the description of the prior art. Like elements in the drawings are denoted by like reference designators.

10 Fig. 3 illustrates an advantageous embodiment of the invention. The Figure shows the structures of both the central station 101 and substation 102. In this explanatory solution according to the invention the central station 101 comprises a baseband processing unit 103 which produces, among other things, the baseband modulated signal for the transmitter unit 107 and processes the baseband signal produced by
15 the receiver unit 104. The processing unit 103 controls the transmitter unit 107 which conveys the data to be transmitted via the duplexer unit 105 to the antenna 106. For reception the central station 101 comprises a receiver unit 104 coupled to the antenna 106 through the duplexer unit 105. The duplexer unit 105 comprises a filter to couple the antenna to the receiver unit 104 on the reception frequency band and a filter to couple the antenna to the transmitter unit on the transmission frequency band. In the arrangement according to the invention the central station 101 transmits at a first frequency f_1 and receives at a second frequency f_2 , which first and second frequencies are different frequencies. The central station transmits a time division multiplexed (TDM) signal where the signals intended for the different
20 substations are in different time slots. To cover the wide transmission and reception frequency bands the central station 101 may have several microwave parts adapted to parallel frequency bands, each part comprising at least an antenna 106, duplexer unit 105, transmitter 107 and a receiver 104. For clarity, Fig. 3 shows these elements only once.

30 The substation 102 comprises at least an antenna 108, switch element 202, transmitter unit 111, receiver unit 110 and a baseband processing unit 112. In the arrangement according to the invention the substations receive at a first frequency f_1

and transmit at a second frequency f_2 . The switch element 202 couples the transmitter unit 111 to the antenna 108 for the duration of transmission and the receiver unit 110 to the antenna 108 for the duration of reception. The operation of the switch 202 is controlled by the baseband processing unit 112 or some other control unit in the substation. Furthermore, the baseband processing unit 112 produces, among other things, the baseband modulated signal for the transmitter unit 111 and processes the baseband signal produced by the receiver unit 110. The substation receives at frequency f_1 at other times than its own transmission turn. In the arrangement according to the invention the substation thus employs dual-frequency time division duplex communications. The central station arranges the uplink and downlink traffic time slots for each substation in such a manner that no substation needs to transmit and receive simultaneously. So, the central station is adapted so as to select the time slots used by the substations.

In the various embodiments of the invention the equipment structures may be different than those shown in Fig. 3. For example, in an advantageous embodiment of the invention the central station does not have a duplexer unit but, instead, the central station has separate antennas for reception and transmission. In such a structure, the transmission and reception signals can be discriminated at least partly on the basis of the dimensions of the transmission and reception antennas. In such an embodiment the receiver branch advantageously includes a reception filter to filter the transmission signal and separate it from the signal to be received. The transmitter branch, too, may advantageously use filtering in order to limit the noise caused by the transmitter on the receiver's frequency band. Also in this embodiment the transmission and reception signals are discriminated at the central station on the basis of frequency.

Thus the different embodiments of the invention are united at least in that the central station comprises means for discriminating the reception signals from transmission signals on the basis of frequency. The discrimination based on frequency can be advantageously realized by means of filter elements. Furthermore, the discrimination based on frequency can be realized at least partly by means of transmitter and receiver antenna dimensions in embodiments where separate antennas are used for transmission and reception.

In the various embodiments of the invention the time division duplex arrangement in the substations may be realized in other ways than coupling the antenna through a switch element to the transmitter for transmission, and to the receiver for reception.

For example, in an advantageous embodiment of the invention the transmitter and receiver in the substation have separate antennas. In such an embodiment the time division duplex arrangement can be realized by switching the transmitter off by some suitable means for the duration of reception.

5 Let us next consider the operation of an arrangement according to the invention in an example case illustrated by Fig. 4, where three substations 102, R1, R2, R3 communicate with the same central station C, 101. The central station transmits to the substations at frequency f_1 , and to the first substation R1 during the time period td_1 , to the second substation R2 during td_2 , and to the third substation R3 during
10 the time period td_3 . The substations, in turn, transmit to the central station at frequency f_2 , and the first substation R1 transmits during the time period tu_1 , the second substation R2 during tu_2 , and the third substation R3 during the time period tu_3 . The reception time slot td_1 of the first substation must be separate from the transmission time slot tu_1 of the same substation, and the same applies to the other
15 substations. Such an arrangement achieves a transmission capacity at the central station that equals that of a dual-frequency system according to the prior art, but this arrangement is considerably easier to implement, since no expensive duplexer units are needed in the substations 102.

Fig. 5 illustrates an example of the timing of the transmission and reception in the arrangement according to Fig. 4. Fig. 5 shows the transmission time slots of the
20 central station C and substations R1, R2 and R3 during an exemplary time period. In Fig. 5 the squares t_1 to t_{18} depict time slots. In the signal of the central station C the horizontally striped time slots are intended for substation R3, vertically striped time slots for substation R1, and the diagonally striped time slots are intended for
25 substation R2. Empty squares indicate time slots during which the transmitter in question is not transmitting payload data. In the example of Fig. 5 the central station C transmits data addressed to substation R3 in time slots t_1 , t_2 , t_7 , t_8 , t_9 , t_{17} and t_{18} , data addressed to substation R1 in time slots t_3 , t_{14} and t_{15} , and data addressed to substation R2 in time slots t_4 , t_5 , t_6 , t_{12} and t_{13} . Correspondingly at substations
30 the striped squares denote time slots during which the substation in question transmits data to the central station. As can be seen from Fig. 5, each substation transmits at different times than it receives from the central station. Thus the substation radio part can be realized without an expensive duplexer unit.

Fig. 5 additionally shows that in an advantageous embodiment of the invention the
35 time slots reserved for substations need not be repeated unchanged. The central

station may control the substations on a per time slot basis, whereby uplink and downlink traffic capacity can be used different amounts for different substations according to the current communications needs. Uplink and downlink traffic capacity can in this way be reserved different amounts for a single substation as well, such as e.g. substation R2, to which the central station transmits in five time slots whereas R2 transmits to the central station in four time slots. Furthermore, the time slots may be divided between the different substations in a manner different than that described here, e.g. constant turns of a certain length for each substation.

In the example of Fig. 5 the downlink connection, i.e. the signal of the central station C, has some unused time slots, in this example time slots t10, t11 and t16. However, the arrangement according to the invention makes it possible to use all the time slots.

The central station may control the substations e.g. by including control commands in the data stream directed to the substations in some known manner.

The above-described arrangement according to the invention involves several advantages. One of the biggest advantages is that no different frequency versions are needed in the implementation of substations but the whole frequency band used can be covered by one single transmitter-receiver structure. Thus the system provider need not produce or store different frequency versions of substations. In addition, in point-to-multipoint connections there are several substations per one central station, so the savings brought by the arrangement according to the invention are significant. Moreover, the arrangement according to the invention gives a central station data transmission capacity as large as that given by the above-described frequency division duplex arrangement according to the prior art. Thus the arrangement utilizes the advantages of the time division duplex arrangement without decreasing the transmission capacity, which is a usual consequence of a solely time division based arrangement, and, on the other hand, achieves the central station data transmission capacity provided by the frequency division duplex system without doubling the data burst rate. The arrangement according to the invention achieves other advantages of the frequency division duplex arrangement as well, e.g. that at the central station the transmission from the transmitter unit of the central station does not disturb the reception at the receiver unit of the central station since the duplex unit discriminates the transmission and reception signals by filtering. This way, the implementation of sectoring and allocation of frequencies is easier. The arrangement according to the invention finds particular application in the

implementation of local multipoint distribution systems (LMDS). In addition, the arrangement according to the invention is applicable to systems according to the HiperAccess standard currently under development at the European Telecommunications Standards Institute (ETSI) and to other broadband radio access network (BRAN) systems as well as to other similar broadband transmission systems. In an advantageous embodiment of the invention the arrangement according to the invention is used to implement a broadband, over 10 Mbps transmission system.

An arrangement like the one described above may also be applied e.g. in a mobile communication network, whereby the central station 101 is advantageously a central station connected to a fixed transmission part of the mobile communication network, and the substation is advantageously located in connection with a base station of the mobile communication network, whereby communication between the base station and the rest of the mobile communication network takes place through the above-described radio link arrangement according to the invention. The radio link arrangement according to the invention can be utilized in conjunction with many different mobile communication systems, such as e.g. GSM (Global System for Mobile communications) or UMTS (Universal Mobile Telecommunication System). In such an embodiment the central station advantageously has a fixed connection or radio link connection with a base station controller (BSC).

Above the invention was described referring to some of its advantageous embodiments, but it is obvious that the invention may be modified in many different ways in accordance with the inventional idea defined by the claims attached hereto.

Claims

1. A data transmission method of a radio link system between a central station (101) and at least one substation (102), **characterized** in that
 - the central station transmits a time division duplex signal at a first frequency,
 - 5 - the central station receives signals of said at least one substation at a second frequency, said second frequency being a different frequency than said first frequency,
 - each of said at least one substation receives substantially at said first frequency during certain first time periods corresponding to the substation in question, and
 - each of said at least one substation transmits substantially at said second frequency
 - 10 during certain second time periods corresponding to the substation in question, whereby said first time periods are different time periods than said second time periods.
2. A data transmission method according to claim 1, **characterized** in that the central station controls the time periods used for transmission and reception by the
- 15 substations.
3. A radio link system comprising a central station (101) and at least one substation (102), **characterized** in that
 - the central station comprises means for discriminating reception signals from transmission signals on the basis of frequency,
 - 20 and in that the central station is arranged so as to transmit at a first frequency and receive at a second frequency,
 - and in that the substation is arranged so as to receive substantially at said first frequency during certain first time periods corresponding to the substation in question and to transmit substantially at said second frequency during certain
 - 25 second time periods corresponding to the substation in question, whereby said first and second time periods are different time periods.
4. A radio link system according to claim 3, **characterized** in that the central station is adapted so as to select said first and second time periods.
5. A radio link system according to claim 3, **characterized** in that it is located in
- 30 a GSM mobile communication system.
6. A radio link system according to claim 3, **characterized** in that it is located in a UMTS mobile communication system.
7. A radio link system according to claim 3, **characterized** in that it is located in

a broadband data transmission system.

8. A radio link system according to claim 7, **characterized** in that it is located in a LMDS system.

5 9. A radio link system according to claim 7, **characterized** in that it is located in a HiperAccess system.

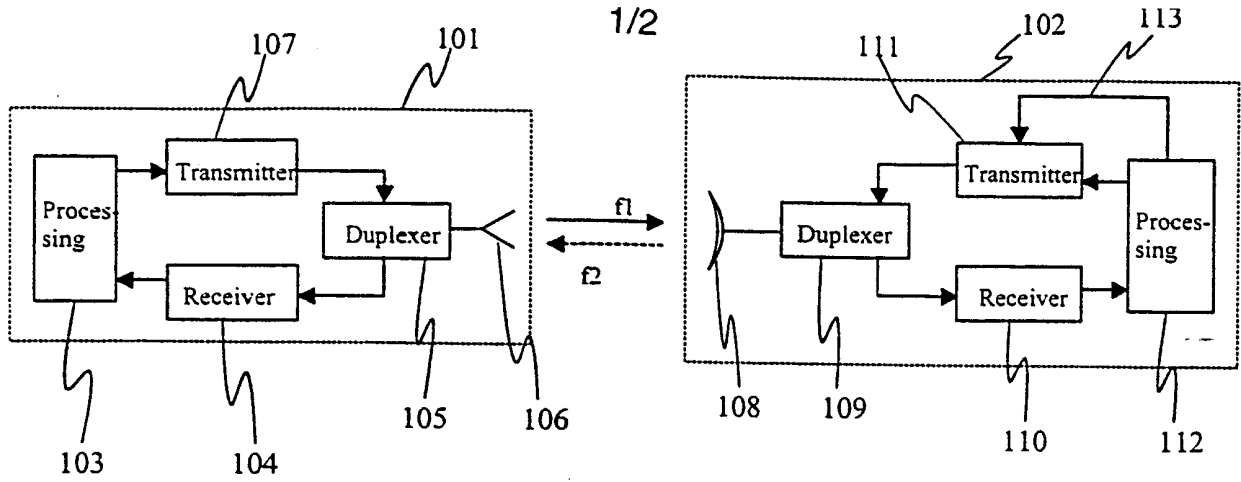

Fig. 1

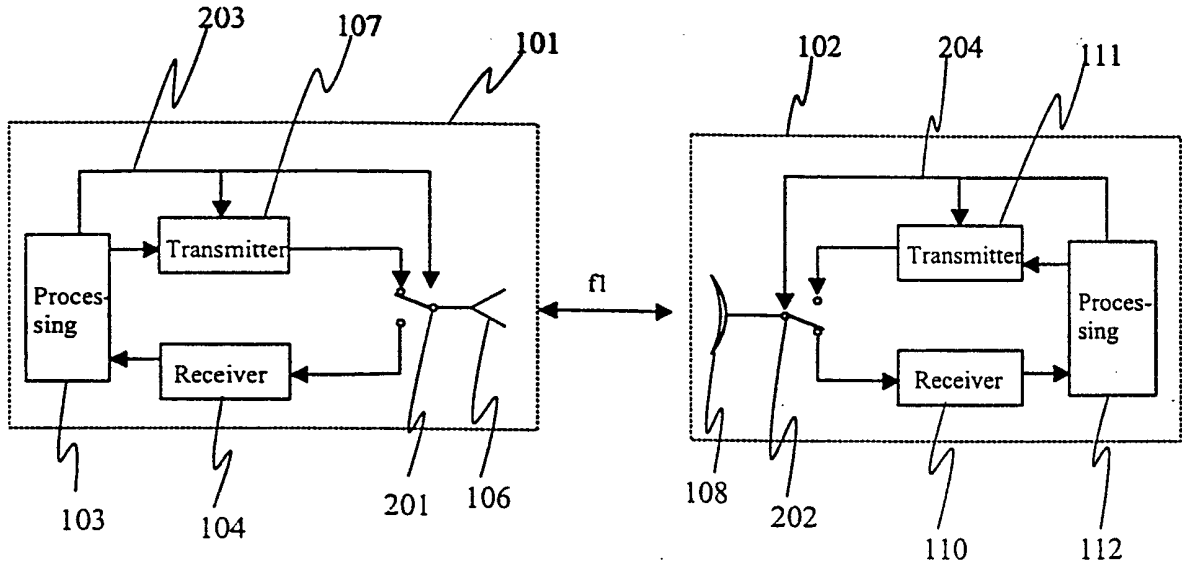
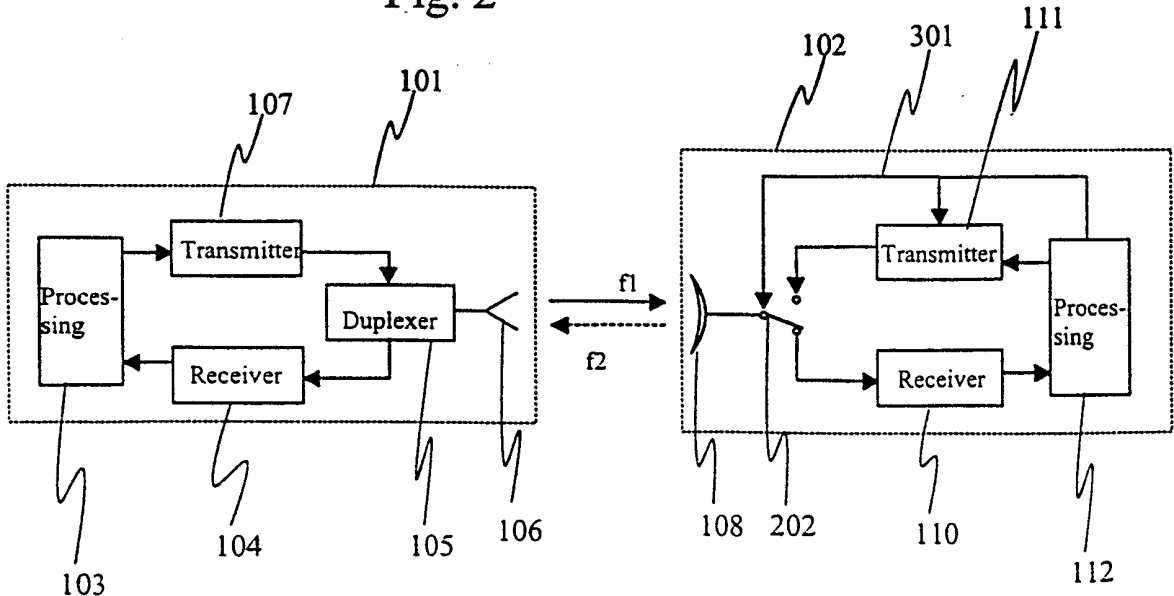

Fig. 2



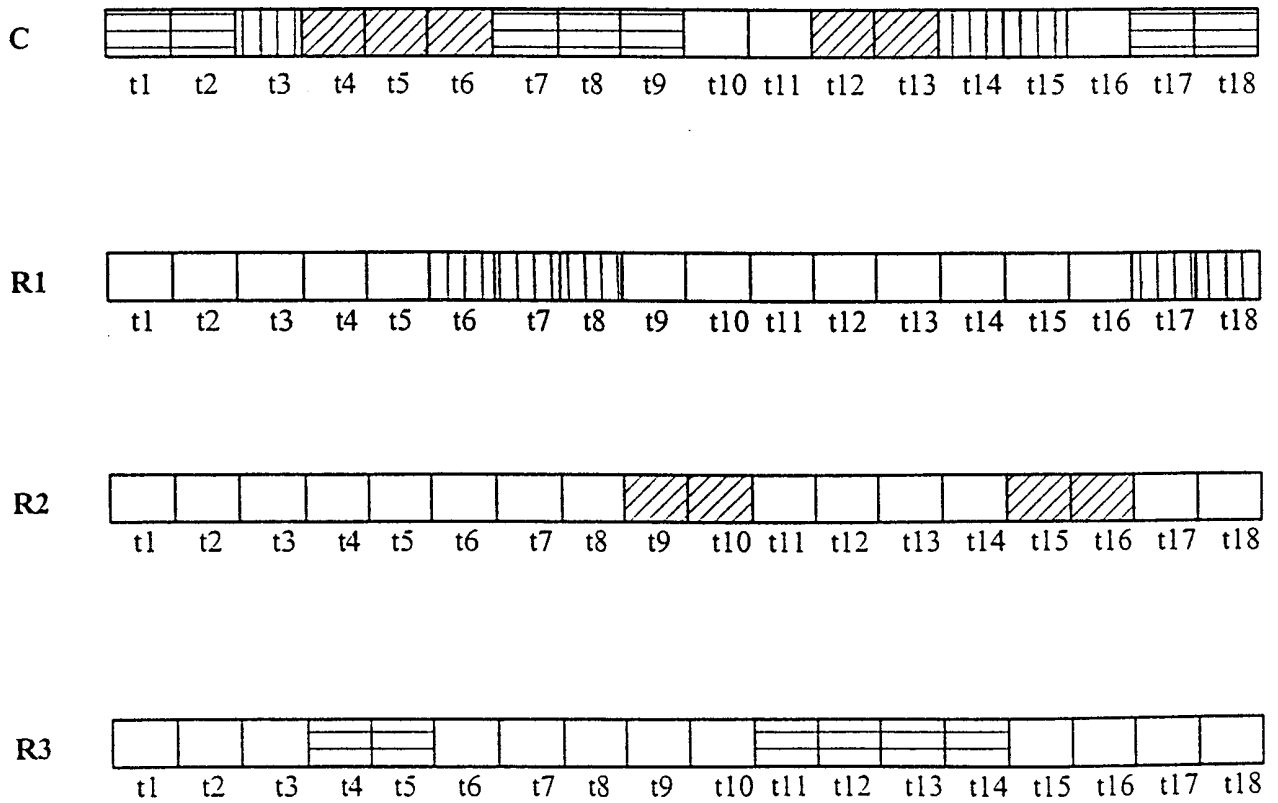
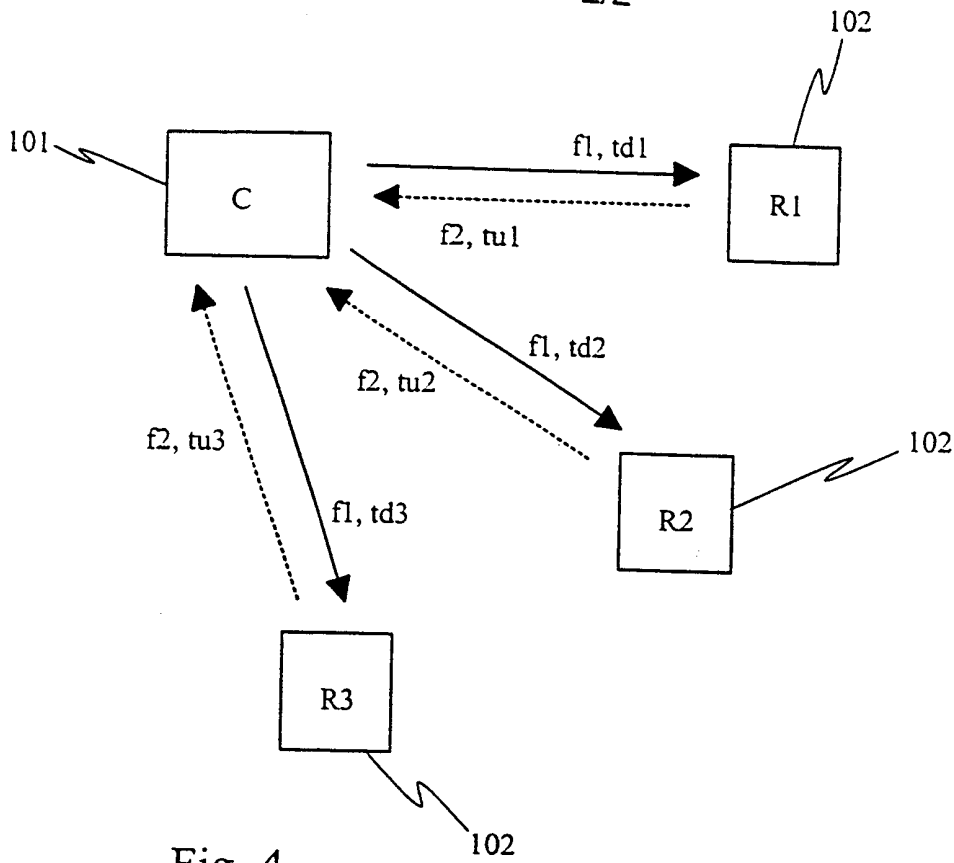

Fig. 5

INTERNATIONAL SEARCH REPORT

International application No.

PCT/FI 00/00174

A. CLASSIFICATION OF SUBJECT MATTER

IPC7: H04B 7/24, H04Q 7/20

According to International Patent Classification (IPC) or to both national classification and IPC

B. FIELDS SEARCHED

Minimum documentation searched (classification system followed by classification symbols)

IPC7: H04B, H04Q

Documentation searched other than minimum documentation to the extent that such documents are included in the fields searched

SE,DK,FI,NO classes as above

Electronic data base consulted during the international search (name of data base and, where practicable, search terms used)

C. DOCUMENTS CONSIDERED TO BE RELEVANT

Category*	Citation of document, with indication, where appropriate, of the relevant passages	Relevant to claim No.
X	US 5617412 A (M. DELPRAT ET AL.), 1 April 1997 (01.04.97), column 6, line 4 - line 13; column 1, line 38 - line 39 --	1,3,5,6
X,P	WO 9926437 A1 (ERICSSON INC.), 27 May 1999 (27.05.99), page 3, line 18 - line 24; page 3, line 24 - page 4, line 2, abstract --	1-4
A	US 5689502 A (L. SCOTT), 18 November 1997 (18.11.97), column 8, line 59 - column 9, line 10 -- -----	1,3

 Further documents are listed in the continuation of Box C. See patent family annex.

* Special categories of cited documents:

"A" document defining the general state of the art which is not considered to be of particular relevance

"E" earlier document but published on or after the international filing date

"L" document which may throw doubts on priority claim(s) or which is cited to establish the publication date of another citation or other special reason (as specified)

"O" document referring to an oral disclosure, use, exhibition or other means

"P" document published prior to the international filing date but later than the priority date claimed

"T" later document published after the international filing date or priority date and not in conflict with the application but cited to understand the principle or theory underlying the invention

"X" document of particular relevance: the claimed invention cannot be considered novel or cannot be considered to involve an inventive step when the document is taken alone

"Y" document of particular relevance: the claimed invention cannot be considered to involve an inventive step when the document is combined with one or more other such documents, such combination being obvious to a person skilled in the art

"&" document member of the same patent family

Date of the actual completion of the international search

19 July 2000

Date of mailing of the international search report

27-07-2000

Name and mailing address of the ISA/
Swedish Patent Office
Box 5055, S-102 42 STOCKHOLM
Facsimile No. +46 8 666 02 86

Authorized officer

Fredrik Blomqvist/AE
Telephone No. +46 8 782 25 00

INTERNATIONAL SEARCH REPORT
 Information on patent family members

02/12/99

International application No.
 PCT/FI 00/00174

Patent document cited in search report	Publication date	Patent family member(s)	Publication date
US 5617412 A	01/04/97	EP 0677930 A FR 2718907 A,B	18/10/95 20/10/95
WO 9926437 A1	27/05/99	AU 1524799 A	07/06/99
US 5689502 A	18/11/97	AU 6025796 A BR 9608548 A CA 2223321 A CN 1192300 A EP 0873593 A IL 118447 D WO 9639749 A	24/12/96 06/07/99 12/12/96 02/09/98 28/10/98 00/00/00 12/12/96