

J. F. KESTER.
ELECTRIC ARC LAMP.

No. 522,327.

Patented July 3, 1894.

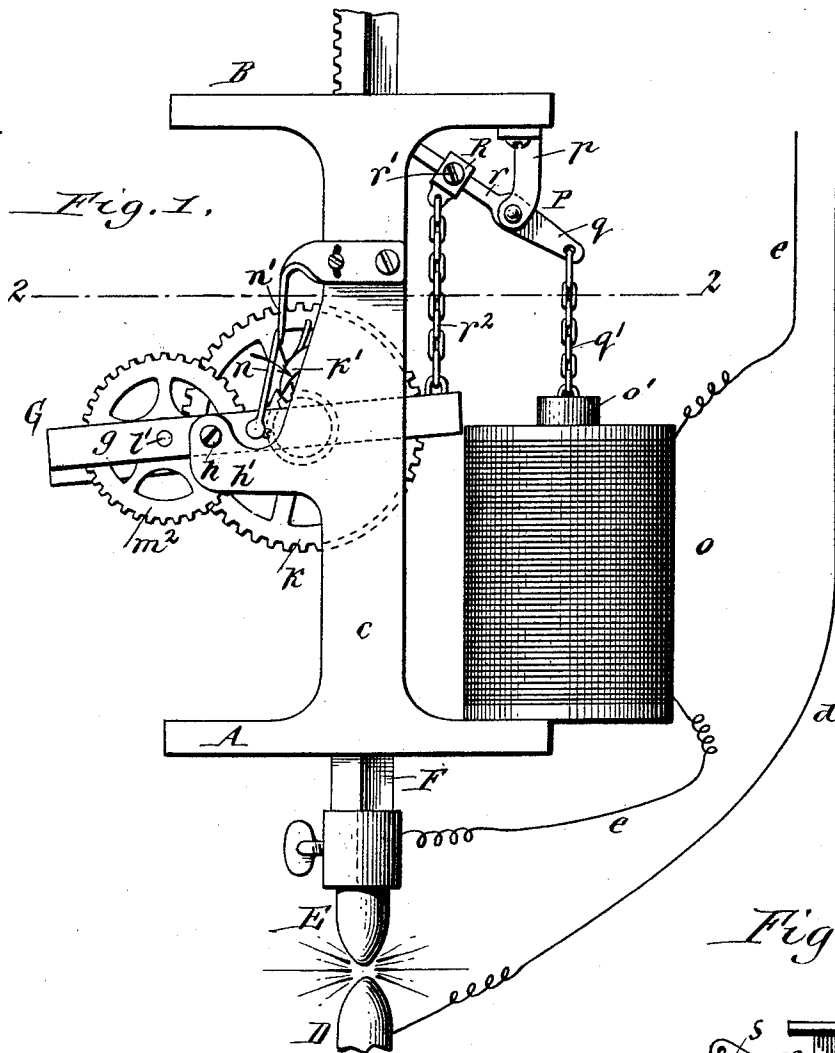

Fig. 1.

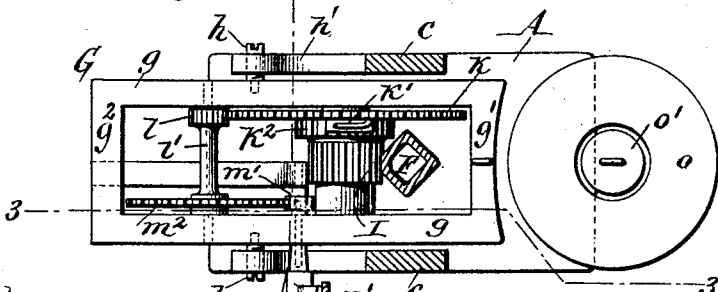
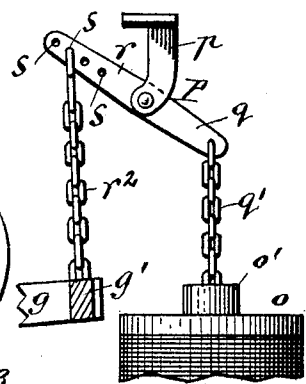

Fig. 2.

Fig. 5.



Witnesses:
 Emil Neuhart.
 Chas. F. Burkhardt.

J. F. Kester Inventor.
 By Wilhelm H. Bonner.
 Attorneys.

J. F. KESTER.
ELECTRIC ARC LAMP.

No. 522,327.

Patented July 3, 1894.

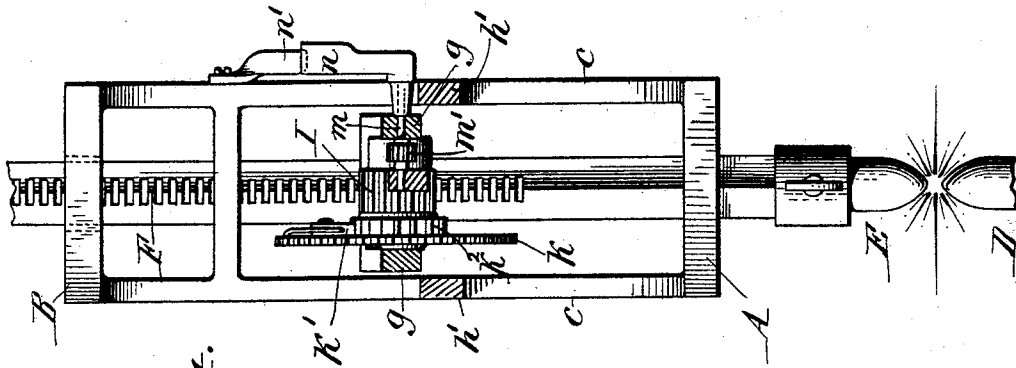

Fig. 1.

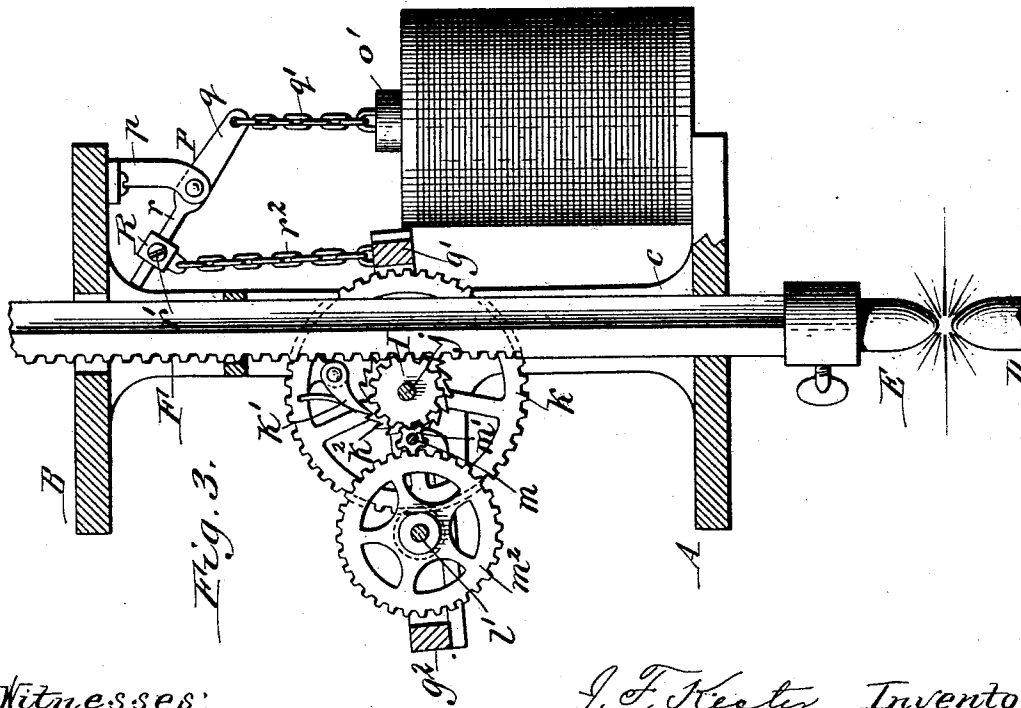

Fig. 3.

Witnesses:

Emil Neuhart
Chas. F. Burkhardt.

J. F. Kester Inventor
By Wilhelm Bonnet
Attorneys

UNITED STATES PATENT OFFICE.

JESSE F. KESTER, OF BUFFALO, NEW YORK, ASSIGNOR TO THE F. P. LITTLE ELECTRICAL CONSTRUCTION AND SUPPLY COMPANY, OF SAME PLACE.

ELECTRIC-ARC LAMP.

SPECIFICATION forming part of Letters Patent No. 522,327, dated July 3, 1894.

Application filed November 23, 1893. Serial No. 491,702. (No model.)

To all whom it may concern:

Be it known that I, JESSE F. KESTER, a citizen of the United States, residing at Buffalo, in the county of Erie and State of New York, have invented new and useful Improvements in Electric-Arc Lamps, of which the following is a specification.

This invention relates to that class of electric lamps in which the feeding mechanism is mounted in a vertically movable frame, which is controlled by a magnet.

One object of this invention is to provide means whereby the leverage between the magnet and the feed mechanism can be varied so that a current of larger or smaller volume or quantity can be used in connection with the lamp.

Another object of my invention is to improve the construction of the feed mechanism so that the vibrations of the magnet armature will not be communicated to the feed mechanism.

In the accompanying drawings:—Figure 1 is a sectional elevation of an electric arc lamp, showing my improvement adapted for use with an alternating current. Fig. 2 is a horizontal section in line 2—2, Fig. 1. Fig. 3 is a vertical longitudinal section in line 3—3, Fig. 2. Fig. 4 is a vertical transverse section in line 4—4, Fig. 1. Fig. 5 is a fragmentary sectional elevation showing a modification of the means for adjusting the leverage between the feed mechanism and the feed magnet.

Like letters of reference refer to like parts in the several figures.

The main frame of the lamp consists essentially of a bottom plate A, a top plate B and vertical side bars *c* connecting said plates.

D represents the lower stationary carbon which is connected with the main circuit wire *d*, and E is the upper movable carbon which is connected with the main circuit wire *e*. The upper carbon is secured to the lower end of a vertically movable rack bar F which is guided in openings formed in the top and bottom plates of the main frame.

G represents a vertically movable carrying frame which is arranged between the side

bars of the main frame and embraces the gear rack. This frame consists essentially of two longitudinal bars *g g* which are pivoted between their inner and outer ends by screws *h* to laterally projecting arms *h'* formed on the side bars *c*, and inner and outer cross bars *g'* *g''* connecting the ends of the longitudinal bars.

I represents a feed gear-wheel meshing with the gear rack F and mounted loosely on a transverse main shaft *j* journaled in the longitudinal bars of the carrying frame on the inner side of the pivot of the latter.

k represents a large gear wheel secured to the main shaft and provided with a pawl *k'* which engages with a ratchet wheel *k''* secured to one side of the feed wheel, thereby compelling the latter to turn with the large gear wheel *k* in one direction, but permitting the feed gear wheel to turn independently of the gear wheel *k*, in the opposite direction.

l is a pinion which meshes with the gear wheel *k* and which is mounted on a counter shaft *l'* journaled in the longitudinal bars of the carrying frame on the outer side of the pivot of the latter.

m represents an intermediate shaft journaled in the carrying frame between the counter shaft and the main shaft and provided inside of said frame with a pinion *m'* which meshes with a gear wheel *m''* secured to the counter shaft.

n represents a rotary stop arm secured to the intermediate shaft *m'* outside of the carrying frame and adapted to engage against a stop *n'* secured to one of the side bars of the main frame preferably above the pivoted frame. This arrangement of the gearing for transmitting the motion from the gear rack to the rotary stop arm is very simple and compact and can be easily assembled.

When the inner portion of the carrying frame is lowered sufficiently to disengage the stop arm *n* from the stop, said arm through the medium of the train of gearing *k, l, m''* and *m'* is rotated by the weight of the upper carbon and its gear rack, in the direction of the arrow in Fig. 1. Upon raising the inner portion of the carrying frame sufficiently to cause the stop arm to strike the stop *n'* the

downward movement of the stop arm, gearing and the upper carbon is arrested.

O represents a feed magnet whereby the inner portion of the carrying frame and the carbon are raised, and which is interposed in one of the wires of the main circuit. This magnet is preferably of the solenoid type and secured with its lower end to the bottom plate of the frame adjacent to the inner end of the carrying frame. o' is the core armature which moves in the magnet.

P represents a rock lever which is pivoted between its ends to a hanger p secured to the underside of the top plate B. The outer arm q of this lever is connected by a chain q' with the armature o' of the magnet.

R represents an adjustable block or collar which is capable of lengthwise adjustment on the other arm r of the rock lever and which is held in position by a set screw r' . This block is connected with the inner cross bar of the carrying frame by a chain r^2 , so that when the magnet becomes energized, the inner end of the carrying frame will be raised, through the medium of the rock lever. When the magnet is de-energized, the inner portion of the carrying frame descends by gravity.

When the carbons are in their normal position and form an arc of normal resistance, the magnet is active and draws the armature downwardly, thereby holding the carrying frame at the proper elevation to engage the rotary stop arm n with the stop n' , whereby the upper carbon is held against downward movement. When the carbons have burned away sufficiently to produce an arc of abnormal resistance, the energy of the magnet becomes less and the armature is raised by the weight of the inner portion of the carrying frame and connecting parts. As soon as the carrying frame has descended sufficiently to liberate the rotary stop arm from the stop, the upper carbon and its gear rack descend by their own weight and rotate the stop arm. When the upper carbon has approached sufficiently close to the lower carbon to restore the normal resistance of the arc, the magnet becomes active again and raises the inner portion of the carrying frame until the stop stands in the path of the rotary arm, when the rotatory movement of the latter and the downward feed of the upper carbon are arrested.

When it is desired to use a small current in the lamp, the adjustable block on the arm r of the rock lever is shifted toward the pivot of the lever, so as to increase the leverage and

enable the carrying frame to be more easily lifted by the magnet.

When it is desired to use a larger current for producing a brighter light, the adjustable block is shifted outwardly from the pivot of the rock lever, so that more power is required to raise the carrying frame for effecting the feed of the upper carbon. By making the leverage between the magnet and the feed mechanism adjustable, the feeding of the upper carbon can be regulated according to the amount of current it is desired to use in the lamp. Instead of employing a sliding block for adjusting the connection between the chain r^2 and the rock lever, the latter may be provided with a longitudinal row of openings s in one of which the chain r^2 is secured, as shown in Fig. 5.

The flow of the current through the magnet when the lamp is in operation causes the armature to vibrate. In lamps as heretofore constructed this vibration was transmitted to the feed mechanism owing to the rigid connection between the armature and the feed mechanism which caused the latter to rattle. By connecting the rock lever with the armature and feed mechanism by means of chains, the vibrations of the armature are spent or absorbed by the looseness of the chain links before reaching the feed mechanism and the transmission of such vibrations to the said mechanism is therefore prevented.

I claim as my invention—

1. The combination with the vertically movable carrying frame and the feed mechanism mounted thereon, of a magnet which controls the movement of said frame, a rock lever having one arm connected with the armature of the magnet, and a block adjustably secured to the other arm of said lever and connected with the carrying frame, substantially as set forth.

2. The combination with the vertically movable carrying frame and the feed mechanism mounted thereon, of a magnet which controls the movement of said frame, and an intermediate rock lever, a chain connecting one arm of said lever with the armature, and a chain connecting the other arm of the lever with the carrying frame, substantially as set forth.

Witness my hand this 30th day of September, 1893.

JESSE F. KESTER.

Witnesses:

THEO. L. POPP,
CHAS. F. BURKHARDT.