

No. 844,792.

PATENTED FEB. 19, 1907.

E. E. GILMORE.
MECHANICAL BAR FOR TROLLEY WIRES.
APPLICATION FILED JAN. 13, 1906.

FIG. 1.

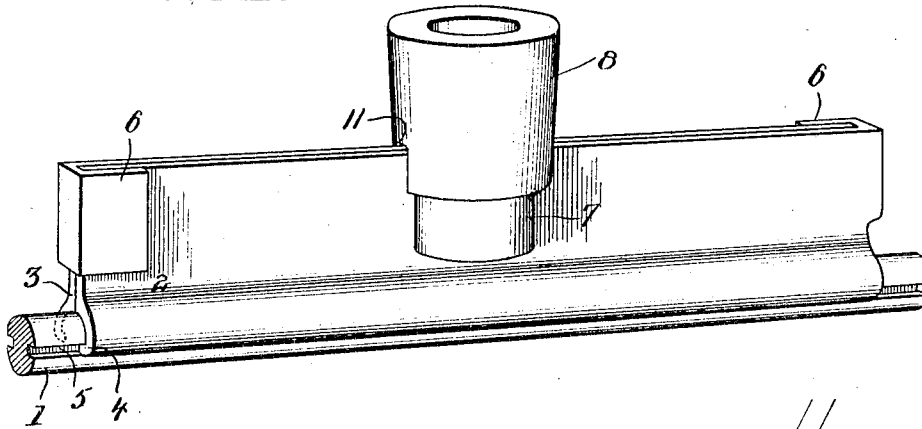

FIG. 2.

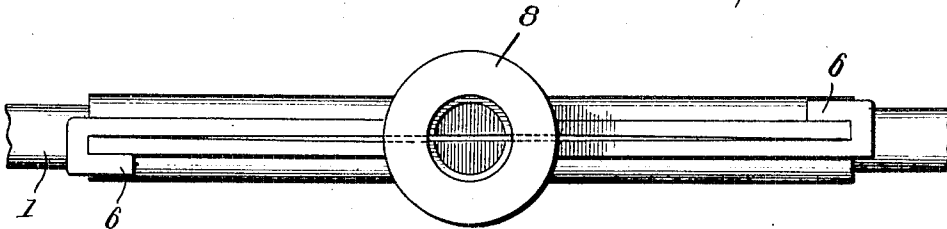
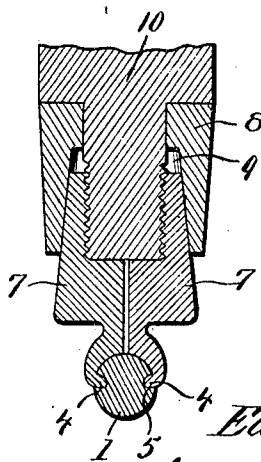

FIG. 3.



Witnesses
H. F. Hoyle
James H. Marr.

Inventor.
Edward E. Gilmore,
by Edward C. Clement
Atty.

UNITED STATES PATENT OFFICE.

EDWARD E. GILMORE, OF PHILADELPHIA, PENNSYLVANIA.

MECHANICAL EAR FOR TROLLEY-WIRES.

No. 844,792.

Specification of Letters Patent.

Patented Feb. 19, 1907.

Application filed January 13, 1906. Serial No. 295,912.

To all whom it may concern:

Be it known that I, EDWARD E. GILMORE, a citizen of the United States, residing at Philadelphia, in the county of Philadelphia and State of Pennsylvania, have invented a certain new and useful Improvement in a Mechanical Ear for Trolley-Wires, of which the following is a specification, reference being had therein to the accompanying drawing.

My invention relates to supporting devices for electrical conductors, and more especially to those devices known in the art as "mechanical ears," and in this instance to those used for 4/0 grooved trolley-wires.

The object of the invention is to provide a simple, cheap, and effective ear or clamp for holding and supporting electrical conductors, and particularly for the bare conductors used on electrical railways.

A further object of the invention is to provide the means whereby the wire is securely and firmly grasped between the jaws, with provision for tightening the jaws at any time should they become loose upon the wires.

Heretofore devices of this character have been designed without any thought as to the future as regards the wear and tear caused by the trolley-wheel passing over. If, for instance, a trolley-pole head becomes tight, the wheel will tend to run to one side on the wire, and when it strikes the point at which the ear is located it causes considerable wear that tends to loosen the grip of the jaws upon the wire. This would be liable to cause accidents, sometimes of a serious nature.

My invention is designed to obviate the above-mentioned difficulties; and to this end it consists in certain features of novelty that will be hereinafter more fully described, and particularly pointed out in the appended claim.

Referring to the drawing, 1 represents the conductor of the type used, and 2 and 3 the two jaws of the clamp. As each of these jaws are similar in all respects and have no right or left, it is evident that it requires only one mold to make both castings, and a description of one will be sufficient for both. The inner face of the jaw is flat, with the exception of the lower or gripping end, which is

flared out to receive the conductor 1 and is provided at its end with a tongue 4, adapted to enter the groove 5 in the body of the conductor. At each end of the jaw a portion of the body is bent back or formed in the casting so as to constitute a flange 6, which lies parallel with the body of the jaw and projects backward toward the opposite end of the jaw.

Midway of each jaw 2 and 3 is an enlarged portion 7, which constitutes one-half of a conical hub extending above the body of the jaw. Each half is provided with internal screw-threads which mate with similar screw-threads in the opposite portion 7.

To clamp the conductor, the two jaws are placed with their inner faces together and with the tongues 4 engaging the groove 5 of the conductor 1, as shown in Fig. 3. The jaws are then slipped endwise on each other until the end of the body of each jaw is engaged by the flange 6. This clamps the conductor and at the same time locks the jaw together so far as lateral movement is concerned, and brings the two sides of the conical hub together, so that the internal screw-threads of each portion 7 will aline. I now place a sleeve or cap 8, having a conical aperture 9, over the conical hub formed by the portions 7 and force it into engagement with the hub by screwing the hanger or bolt 10 down upon the top of the cap. This not only makes an excellent support, but allows for tightening of the jaws upon the conductor 1 at any time it is necessary.

In practice the hangers 10 are usually connected to an insulator of any suitable type and through the insulator to the cross-arm or supporting-wire of the trolley-post.

The cap 8 is slotted at 11 on either side, so as to allow it to pass down and straddle both of the jaws 2 3. This allows any amount of adjustment which may be necessary and prevents rotation of the cap.

Having thus described my invention, what I claim, and desire to secure by Letters Patent, is—

In a mechanical ear for trolley-wires the combination with a pair of jaws, of tongues on each of said jaws, said tongues being pre-

55

60

65

70

75

80

85

90

95

100

sented in opposite directions and adapted to lock the jaws against relative lateral movement, a conical hub, and a cap for engaging said hub for locking the jaws against relative longitudinal movement said cap being slotted to engage the jaws to prevent its rotation.

In testimony whereof I have affixed my signature in presence of two witnesses.

EDWARD E. GILMORE.

Witnesses:

JAS. HEYWOOD,
DAVID M. ASHLEY