

(19)
(12)

(KR)
(A)

(51) 。 Int. Cl. ⁷
B65D 85/00

(11)
(43)

2002 - 0063473
2002 08 03

(21) 10 - 2001 - 0020220
(22) 2001 04 16
(62) 2001 - 0001927
: 2001 01 27

(71) 987 - 8

(72) 1194 105 705

(74)
:

(54)

가 ,

가 ,

가 .

가 ,

가 .

가

4

, , , .

1

.

2

.

3

.

4

.

5

1 A - A

.

6a

.

6b ~ 6c

.

7

.

8

.

(corrupad)

,

,

가

(2)

1

(110)

(1)

(110)

(2)

(1)

가 , , ,

가 , 가

가 가

(VTR, VCDR)

(corrupad)

가 , 가

1 , 2 , 3

4 , 5 1 A - A

6a ~ 6c , 7 , 8

2 8 , 1 (10), (20), (40), (50), 2 (70), (70a) (80) (100)

1 (10) (11)

(20) (21) (80) 1 (30) 1 (31) 가 , (32) (31a) (30a)

(40) (41) ,

(50) (51) (52) , (61) 가 2 (60)

2 (70) 2 (71) 가 (70a)

가 (30a) (32) (80) (32)

1 (30a) 1 (31) (30a) (31)

a) (30) (20) (21) (30a) (31)

1 (30) (30a) 1 (31) 1 (

10) (11) (40) (41)

2 (71) (71) (70a) 2 (70) 2

(71) (50) 1 (60) (61) (61)

가 가 (100) (80)

(20) (corrupad) (90)

2 8

1 (10), (20), (40), (50), 2 (70), (70a)

(80)

1 (10) (80) (11)

(20) (21) (80) 1 (30) 1

(31) 가 1 (31) (32) 가

(31a) 가 (30a)

(32)가 (30a) (32) (80)

30a) 1 (30) (20) (31) (21) (30a) (

(31a)

(32)

1 (30) (30a) 1 (31) 1

(10) (11) (40) (41)

(20) (corrupad) (90) (100)

(101)

(90) (100) (101)

(90)

(90) , 6b (90) 6a ~ 6c (corrupad) 6a (90)
가 .

(40) (41) ,

(50) (51) (52) , (61) 가 2
(60) ,

2 (70) 2 (71) 가 (70a) .

2 (71) (71) (70a) 2 (70) , 2
(71) (50) 1 (60) (61) .
(102) ,

(32) (50) (51) (52)
(100) (101) (110)

(110) ,
(100) (100) (corrupad) ,
가 .
, 7 ~ 8 (10) (11)
(50a) ,

(20) (21) (80) ,
(30) (31) 가 , (31) .
(32) (31a) (30a) ,
(40) (41) (50b) ,
(50a) , (50b) (52) ,
(90) (100) .

(corrupad)
(VTR, VCDR)

가 , 가 가

(57)

1.

1 (10), (20), (40), (50), 2 (70), (70a)
 (80) (100) ,
 , 1 (10) (11) ,
 (20) (21) (80) , 1 (30) 1
 (31) 가 , • (32) (31a) (30a)
 ,
 (40) (41) ,
 (50) (51) (52) , (61) 가 2
 (60)
 2 (70) 2 (71) 가 (70a) ,
 가 ,
 (100) (corrupad) ` □ ` (90) , (102)
 (100).

2.

1 .
 (11) (50a) (10) ,
 (21) (80) 가 (20) ,
 (30) (31) 가 , (31) •
 (32) (31a) (30a) ,
 (41) (50b) 가 (40) ,
 (50a) , (50b) (52) ,
 (90) (100) .

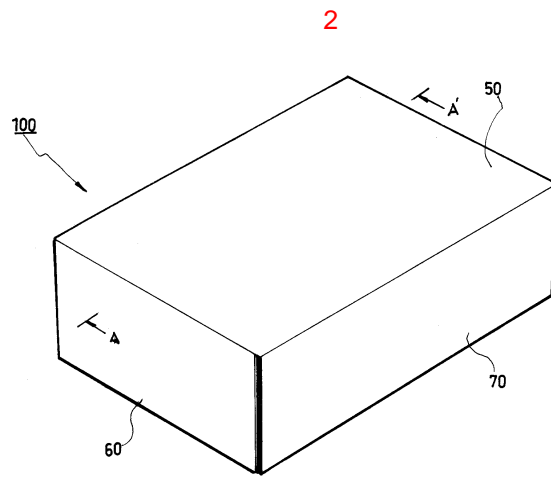
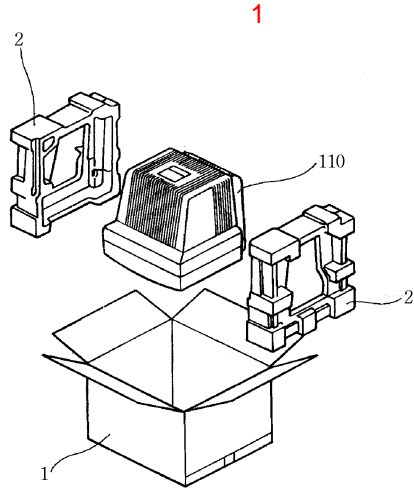

3

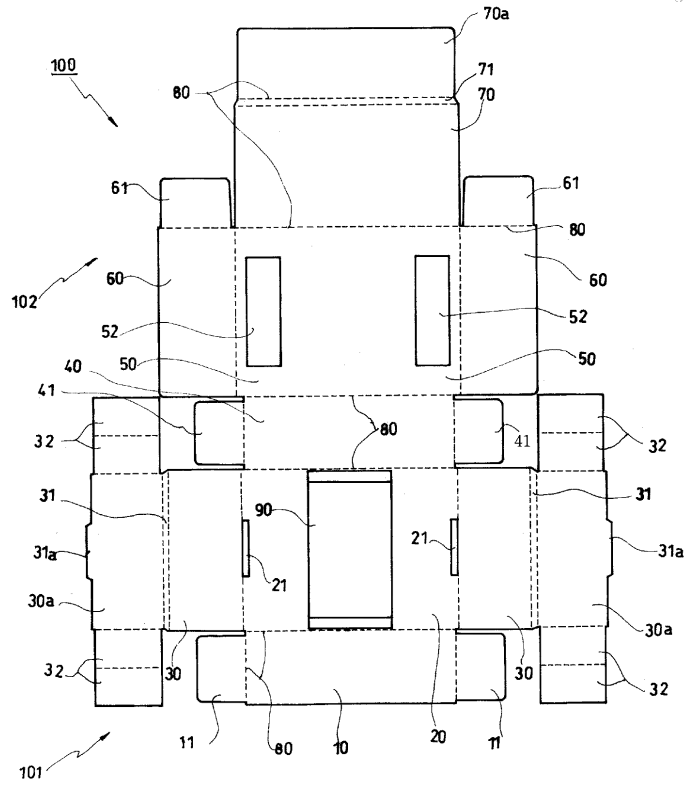

4

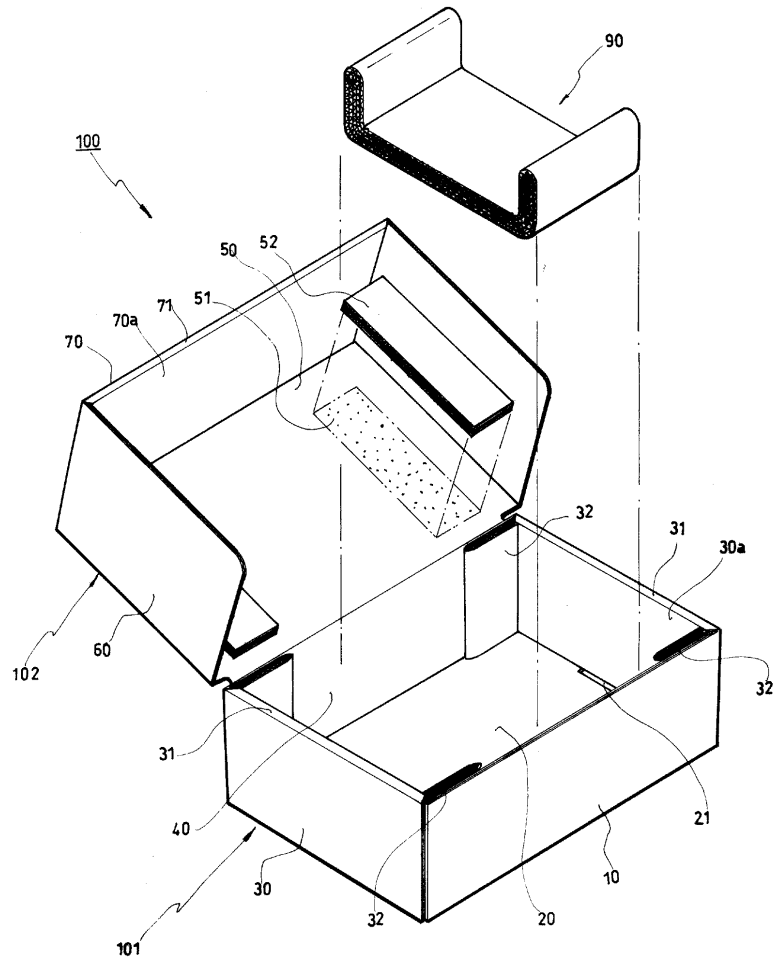

5

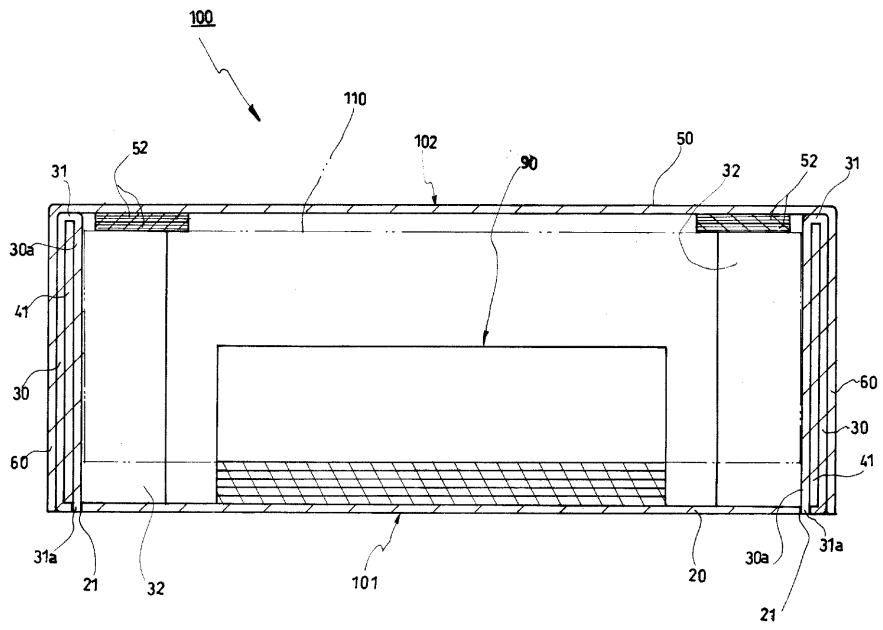

6a

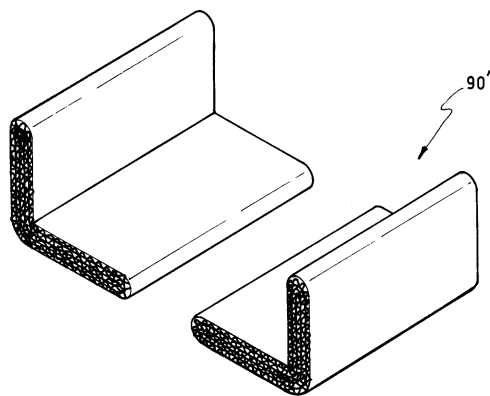

6b

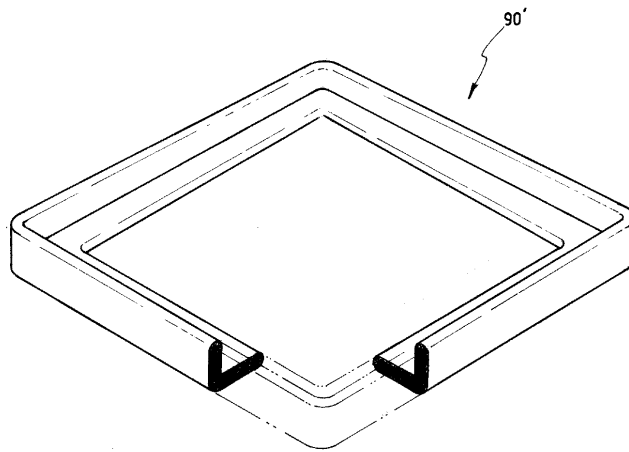

6c

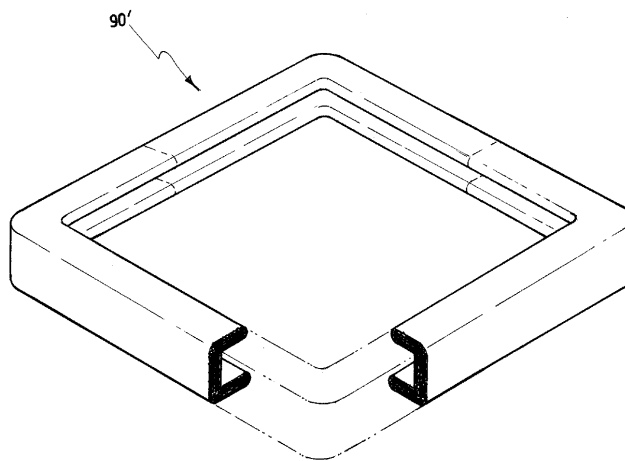

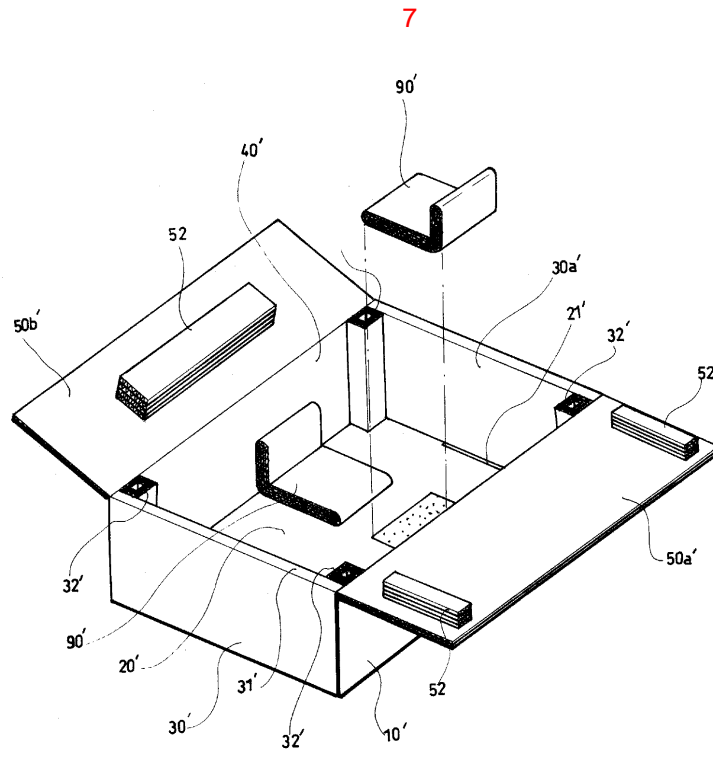

8

