

(19) World Intellectual Property Organization
International Bureau



(43) International Publication Date
23 November 2006 (23.11.2006)

PCT

(10) International Publication Number
WO 2006/124649 A2

- (51) International Patent Classification:
A61F 2/24 (2006.01)
- (21) International Application Number:
PCT/US2006/018514
- (22) International Filing Date: 12 May 2006 (12.05.2006)
- (25) Filing Language: English
- (26) Publication Language: English
- (30) Priority Data:
11/128,826 13 May 2005 (13.05.2005) US
- (71) Applicant (for all designated States except US):
COREVALVE, INC. [FR/FR]; 2 Jenner 100, Irvine, CA 92618 (US).
- (72) Inventors; and
- (75) Inventors/Applicants (for US only): NGUYEN, Than [US/US]; 1132 Athens Avenue, Placentia, CA 92870 (US). NGUYEN, Hung [US/US]; 13929 Magnolia Street, Garden Grove, CA 92844 (US). NGUYEN, MyKim [US/US]; 1221 N Hastings Street, Santa Ana, CA 92703 (US). KOMATSU, Stanley [US/US]; 25412 Champlain Road, Laguna Hills, CA 92653 (US). MICHELIS, Robert [US/US]; 25782 Carlson Court, Laguna Hills, CA 92653 (US).
- (74) Agent: PISANO, Nicola, A.; Luce, Forward, Hamilton & Scripps, LLP, 11988 El Camino Real, Suite 200, San Diego, CA 92130 (US).
- (81) Designated States (unless otherwise indicated, for every kind of national protection available): AE, AG, AL, AM, AT, AU, AZ, BA, BB, BG, BR, BW, BY, BZ, CA, CH, CN, CO, CR, CU, CZ, DE, DK, DM, DZ, EC, EE, EG, ES, FI, GB, GD, GE, GH, GM, HR, HU, ID, IL, IN, IS, JP, KE, KG, KM, KN, KP, KR, KZ, LC, LK, LR, LS, LT, LU, LV, LY, MA, MD, MG, MK, MN, MW, MX, MZ, NA, NG, NI, NO, NZ, OM, PG, PH, PL, PT, RO, RU, SC, SD, SE, SG, SK, SL, SM, SY, TJ, TM, TN, TR, TT, TZ, UA, UG, US, UZ, VC, VN, YU, ZA, ZM, ZW.
- (84) Designated States (unless otherwise indicated, for every kind of regional protection available): ARIPO (BW, GH, GM, KE, LS, MW, MZ, NA, SD, SL, SZ, TZ, UG, ZM, ZW), Eurasian (AM, AZ, BY, KG, KZ, MD, RU, TJ, TM), European (AT, BE, BG, CH, CY, CZ, DE, DK, EE, ES, FI, FR, GB, GR, HU, IE, IS, IT, LT, LU, LV, MC, NL, PL, PT, RO, SE, SI, SK, TR), OAPI (BF, BJ, CF, CG, CI, CM, GA, GN, GQ, GW, ML, MR, NE, SN, TD, TG).

Published:
— without international search report and to be republished upon receipt of that report

[Continued on next page]

(54) Title: HEART VALVE PROTHESIS AND METHODS OF MANUFACTURE AND USE

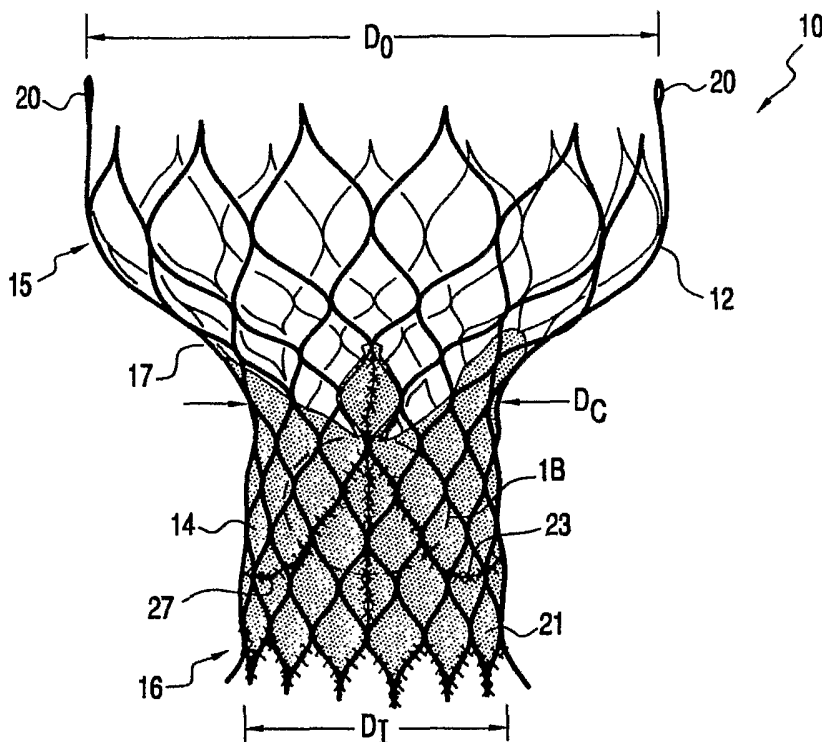

(57) Abstract: A heart valve prosthesis is provided having a self-expanding multi-level frame that supports a valve body comprising a skirt and plurality of coapting leaflets. The frame transitions between a contracted delivery configuration that enables percutaneous transluminal delivery, and an expanded deployed configuration having an asymmetric hourglass shape. The valve body skirt and leaflets are constructed so that the center of coaptation may be selected to reduce horizontal forces applied to the commissures of the valve, and to efficiently distribute and transmit forces along the leaflets and to the frame. Alternatively, the valve body may be used as a surgically implantable replacement valve prosthesis.

WO 2006/124649 A2



For two-letter codes and other abbreviations, refer to the "Guidance Notes on Codes and Abbreviations" appearing at the beginning of each regular issue of the PCT Gazette.

HEART VALVE PROSTHESIS AND
METHODS OF MANUFACTURE AND USE

5 Field Of The Invention

The present invention relates to replacement valves for improving the cardiac function of a patient suffering from cardiac valve dysfunction, such as aortic valve regurgitation or aortic stenosis. More particularly, the present invention relates to heart valve prostheses that provide improved durability and are particularly well-suited for percutaneous delivery.

Background Of The Invention

15 Heart valve replacement has become a routine surgical procedure for patients suffering from valve regurgitation or stenotic calcification of the leaflets. While certain procedures may be performed using minimally-invasive techniques (so-called "keyhole" techniques), the vast majority of valve replacements entail full sternotomy and placing the patient on cardiopulmonary bypass. Traditional open surgery inflicts significant patient trauma and discomfort, requires extensive recuperation times, and may result in life-threatening complications.

To address these concerns, within the last decade efforts have been made to perform cardiac valve replacements using minimally-invasive techniques. In

these methods, laparoscopic instruments are employed to make small openings through the patient's ribs to provide access to the heart. While considerable effort has been devoted to such techniques, widespread acceptance has
5 been limited by the clinician's ability to access only certain regions of the heart using laparoscopic instruments.

Still other efforts have been focused on percutaneous transluminal delivery of replacement cardiac
10 valves to solve the problems presented by traditional open surgery and minimally-invasive surgical methods. In such methods, a valve prosthesis is compacted for delivery in a catheter and then advanced, for example, through an opening in the femoral artery and through the
15 descending aorta to the heart, where the prosthesis then is deployed in the aortic valve annulus. Although transluminal techniques have attained widespread acceptance with respect to delivery of stents to restore vessel patency, only mixed results have been obtained
20 with respect to percutaneous delivery of relatively more complicated valve prostheses.

One such example of a previously-known heart valve prosthesis is described in U.S. Patent No. 6,454,799 to Schreck. The prosthesis described in that
25 patent comprises a fabric-based heart valve disposed within a plastically deformable wire-mesh base, and is delivered via expansion of a balloon catheter. One drawback with balloon catheter delivery of the prosthetic valve is that the valve leaflets may be damaged when
30 compressed between the balloon and the base during deployment. In addition, because balloon expandable structures tend to experience some recoil following

balloon deflation, perivalvular leaks may develop around the circumference of the valve prosthesis.

Accordingly it would be desirable to provide a percutaneously-deliverable valve prosthesis that reduces
5 the risk of leaflet damage during deployment of the prosthesis. It further would be desirable to provide a valve prosthesis that reduces the risk of perivalvular leaks resulting from recoil of the prosthesis following deployment.

10 U.S. Patent No. 6,027,525 to Suh, et al. describes a valve prosthesis comprising a series of self-expanding units affixed to a polymeric cover and having a valve disposed therein. Such devices are not suitable for cardiac valve replacement because of the limited
15 ability to compact the valve disposed within the prosthesis. Moreover, such valve prostheses would be particularly undesirable for treating aortic valve defects, because the polymeric cover would obscure the ostia of the coronary arteries, both disrupting blood
20 flow to the coronary arteries and preventing subsequent catheterization of those arteries. Accordingly, it would be desirable to provide a valve prosthesis that is self-expanding, yet permits the valve to be compacted to a greater degree than previously-known designs.

25 U.S. Patent No. 6,682,559 to Myers, et al. also describes a valve prosthesis having an essentially tubular design. One drawback of such configurations is that relatively large horizontal forces arise along the coaptation edges of the leaflets and are transmitted to
30 the commissural points. These forces may adversely affect the durability of the leaflets and lead to valve failure. In view of this, it would be desirable to provide a valve wherein the center of coaptation of the

leaflets may be selected so as to reduce horizontal forces applied to coaptation edges of the leaflets and commissural points, thereby improving durability of the valve. In addition, it would be desirable to provide a
5 valve design that more uniformly distributes horizontal forces over the coaptation edges of the leaflets, rather than concentrating those forces at the commissural points.

In an effort to more nearly recreate the force
10 distribution along the leaflets of natural tissue valves, some previously-known valve designs include circular base portions having longitudinal projections that function as anchors for the commissural points, such as described in U.S. Patent No. 5,855,601 to Bessler, et al. and U.S.
15 Patent No. 6,582,462 to Andersen, et al.

While the valve prostheses of Bessler and Andersen may be readily collapsed for delivery, those designs are susceptible to problems once deployed. For example, the longitudinal projections of such prostheses
20 may not provide sufficient rigidity to withstand compressive forces applied during normal movements of the heart. Deformation of the commissural anchors may result in varied forces being imposed on the commissures and leaflets, in turn adversely impacting functioning of the
25 leaflets. In addition, because the exteriors of the foregoing valve prostheses are substantially cylindrical, the prostheses are less likely to adequately conform to, and become anchored within the valve annulus anatomy during deployment. As a result, cyclic loading of the
30 valve may result in some slippage or migration of the anchor relative to the patient's anatomy.

In view of the foregoing, it would be desirable to provide a valve that is capable of conforming to a

patient's anatomy while providing a uniform degree of rigidity and protection for critical valve components.

It also would be desirable to provide a valve prosthesis having portions that are capable of deforming
5 circumferentially to adapt to the shape of the pre-existing valve annulus, but which is not susceptible to deformation or migration due to normal movement of the heart.

It further would be desirable to provide a
10 valve prosthesis having a multi-level component that is anatomically shaped when deployed, thereby enhancing anchoring of the valve and reducing the risk of migration and perivalvular leaks.

It still further would be desirable to provide
15 a valve prosthesis wherein the valve body is configured to facilitate fabrication, and to assume a reduced delivery profile compared to previously known designs without damaging the functional components of the valve body.

20

Summary Of The Invention

In view of the foregoing, it is an object of the present invention to provide a valve prosthesis that overcomes the drawbacks of previously-known designs, and
25 which may be implanted using open surgical, minimally invasive, or percutaneous implantation techniques.

It is yet another object of the present invention to provide a percutaneously-deliverable valve prosthesis that exhibits a markedly reduced delivery
30 profile over known designs.

It is also an object of the present invention to provide a percutaneously-deliverable valve prosthesis that reduces the risk of damage to the leaflets or other

functional components of the valve body during delivery and deployment of the prosthesis.

It is a further object of this invention to provide a valve prosthesis that reduces the risk of
5 perivalvular leaks resulting from elastic recoil of the prosthesis following deployment.

It is another object of the present invention to provide a valve prosthesis that is self-expanding and permits ready access to adjoining anatomical structures,
10 such as the coronary arteries.

It is a still further object of the present invention to provide a valve in which the center of coaptation of the leaflets may be selected so as to reduce horizontal forces applied to coaptation edges of
15 the leaflets and commissural points, thereby improving durability of the valve.

In addition, it is an object of this invention to provide a valve design that more uniformly distributes forces over the coaptation edges of the leaflets, rather
20 than concentrating those forces at the commissural points.

It is yet another object of this invention to provide a valve that is anatomically shaped, provides a uniform high degree of rigidity and protection for
25 critical valve components, and which is less susceptible to deformation arising from normal movement of the heart.

It is an object of the present invention to provide a valve prosthesis having portions that are capable of deforming circumferentially to adapt to the
30 shape of the pre-existing valve annulus, but which is not susceptible to deformation or migration due to normal movement of the heart.

It is also an object of this invention to provide a valve prosthesis having a multi-level component that is anatomically shaped when deployed, thereby enhancing anchoring of the valve and reducing the risk of migration and perivalvular leaks.

It is a further object of the present invention to provide a valve prosthesis wherein a valve is disposed within a rigid portion of a multilevel frame, so that valve area and function are not impaired, but inflow and/or outflow portions of the multilevel frame are capable of conforming to patient anatomy anomalies.

It is a further object of the present invention to provide a valve prosthesis that facilitates alignment of the heart valve prosthesis with the direction of blood flow.

These and other objects of the present invention are accomplished by providing a heart valve prosthesis wherein a self-expanding multi-level frame supports a valve body comprising a skirt and plurality of coapting leaflets. The frame has a contracted delivery configuration, in which the prosthesis may be stored within a catheter for percutaneous delivery, and an expanded deployed configuration having an asymmetric hourglass shape.

In a first preferred embodiment, the valve body skirt and leaflets are constructed of porcine, bovine, equine or other mammalian tissue, such as pericardial tissue, and are sewn, welded, molded or glued together so as to efficiently distribute forces along the leaflets and to the frame. In a particularly preferred embodiment, the skirt comprises three sections of mammalian tissue that are joined along adjacent edges, so

that the tissue folds easily to a collapsed delivery profile without bunching.

Alternatively, the skirt of the valve body may comprise a synthetic or polymeric material, such as
5 Dacron, expanded polytetrafluoroethylene ("ePTFE"), or other suitable synthetic graft material. The valve body leaflets may be constructed of porcine, bovine, equine or other mammalian tissue, such as pericardial tissue, and are sewn, welded, molded or glued to the skirt so as to
10 efficiently distribute forces along the leaflets and to the frame. The use of synthetic or polymeric materials for the valve skirt in conjunction with mammalian tissue leaflets may offer distinct advantages. In particular, the synthetic material may provide the same structural
15 properties as the mammalian tissue but at reduced thickness, thereby enabling the valve body to be collapsed to a smaller delivery profile. Alternatively, the leaflets also may comprise a synthetic or polymeric material.

20 In accordance with the principles of the present invention, the frame comprises multiple levels, including a proximal conical inflow section, a constriction region and a flared distal outflow section. Each of the inflow and outflow sections is capable of
25 deforming to a non-circular cross-section to conform to the patient's anatomy, while the constriction region is configured to retain a circular cross-section that preserves proper functioning of the valve body.

The frame comprises a plurality of cells having
30 a pattern that varies along the length of the frame to provide a high degree of anchoring and alignment of the valve prosthesis. The cell pattern further is selected to provide a uniform diameter where the commissural

5 joints of the leaflets are attached to the frame, while permitting the inflow and outflow regions to expand to conform to the patient's anatomy. In this manner, optimal functioning of the valve body may be obtained even though the frame may be deployed in anatomies having a range of sizes. In addition, the frame resists deformation caused by movement of the heart and enables a functional portion of the valve body to be disposed supra-annularly to the native valve, with a portion of the valve prosthesis extending into the native valve
10 annulus.

In one embodiment suitable for aortic valve replacement, the valve body comprises a skirt coupled to three leaflets. The components may be formed of animal
15 pericardial tissue or synthetic material, and are sewn, glued, welded or molded together. The lateral ends of the leaflets include enlarged regions that are folded to both form the commissural joints and fasten the commissural joints to the frame. The skirt and leaflets
20 further are configured so that the joints align with contours of the cell pattern of the frame.

In a preferred embodiment, the commissural joints are affixed to the frame at locations above the area of coaptation, to provide a selectable center of
25 coaptation of the leaflets. This design provides a more efficient delivery configuration because the commissures are not compressed against the leaflets when the valve prosthesis is reduced to the contracted delivery configuration. Additionally, by lengthening the distance
30 to the commissures, the design mimics the functioning of natural tissue valves by distributing forces along the coaptation edges and reducing horizontal forces transmitted to the commissural joints.

In alternative embodiments, the valve body of the present invention may include a sewing ring in lieu of the frame to facilitate surgical implantation, and may employ as few as two and as many as four leaflets.

5 Methods of making and using the valve prostheses of the present invention are also provided.

Brief Description Of The Drawings

10 The above and other objects and advantages of the present invention will be apparent upon consideration of the following detailed description, taken in conjunction with the accompanying drawings, in which like reference numerals refer to like parts throughout, and in which:

15 FIGS. 1A, 1B and 1C are, respectively, side and top end views of an exemplary valve prosthesis of the present invention in the expanded deployed configuration and an enlarged region of the frame of the valve prosthesis;

20 FIG. 2 is a side view of the frame of the valve prosthesis of FIGS. 1 in a contracted delivery configuration;

25 FIGS. 3A and 3B are, respectively, plan views of a leaflet and the skirt employed in the valve body of the present invention;

30 FIGS. 4A, 4B, 4C, and 4D are, respectively, a perspective view of a leaflet with its enlarged regions folded, a plan view of an embodiment of the valve body of the present invention in which the leaflets are fastened to the skirt, a perspective view of an alternative embodiment of a skirt, and a perspective view of another alternative embodiment of a skirt;

 FIG. 5 is a side view of the valve body of FIG. 4B fully assembled; and

FIG. 6 is a side view depicting the valve prosthesis of the present invention deployed atop a patient's aortic valve.

5 Detailed Description Of The Invention

The present invention is directed to a heart valve prosthesis having a self-expanding frame that supports a valve body. In a preferred embodiment, the frame has a tri-level asymmetric hourglass shape with a
10 conical proximal section, an enlarged distal section and a constriction region having a predefined curvature when the frame is deployed. In the context of the present application, the proximal section constitutes the
15 "inflow" portion of the valve prosthesis and is disposed in the aortic annulus of the patient's left ventricle, while the distal section constitutes the "outflow" portion of the valve prosthesis and is positioned in the patient's ascending aorta.

In a preferred embodiment the valve body
20 comprises three leaflets that are fastened together at enlarged lateral end regions to form commissural joints, with the unattached edges forming the coaptation edges of the valve. The leaflets are fastened to a skirt, which is in turn affixed to the frame. The enlarged lateral
25 end regions of the leaflets permit the material to be folded over to enhance durability of the valve and reduce stress concentration points that could lead to fatigue or tearing of the leaflets. The commissural joints are mounted above the plane of the coaptation edges of the
30 valve body to minimize the contracted delivery profile of the valve prosthesis, while the configuration of the edges permits uniform stress distribution along the coaptation edges.

Referring to FIGS. 1, an exemplary embodiment of a valve prosthesis constructed in accordance with the principles of the present invention is described. Valve prosthesis 10 comprises expandable frame 12 having valve body 14 affixed to its interior surface, e.g., by sutures. Frame 12 preferably comprises a self-expanding structure formed by laser cutting or etching a metal alloy tube comprising, for example, stainless steel or a shape memory material such as nickel titanium. The frame has an expanded deployed configuration that is impressed upon the metal alloy tube using techniques that are per se known in the art. Valve body 14 preferably comprises individual leaflets assembled to a skirt. All of the components of valve body 14, i.e., the skirt and leaflets, may be formed of a natural or man-made material. Alternatively, the leaflets may be formed from a natural material, such as porcine, equine or bovine pericardium, while the skirt comprises a synthetic or polymeric material, such as Dacron, ePTFE, or similar material.

Frame 12 preferably includes multiple levels, including outflow section 15, inflow section 16 and constriction region 17. As depicted in the enlarged view of FIG. 1B, the frame comprises a plurality of cells having sizes that vary along the length of the prosthesis. As indicated by dotted lines **a**, **b** and **c**, each cell comprises two zig-zag structures having unequal-length struts, wherein the vertices of the zig-zags are coupled together. For example, zig-zag 18 has length z_1 whereas zig-zag 19 has greater length z_2 . This cell design permits each level of cells between the proximal and distal ends of the frame to be tailored to meet specific design requirements, such as,

compressibility, expansion characteristics, radial strength and so as to define a suitable contour for attachment of the valve body.

The cell pattern of frame 12 also enables the frame to expand to the tri-level asymmetric hourglass shape depicted in FIG. 1A, having conical inflow section, enlarged outflow section and fixed diameter constricted region. Each section of frame 12 has a substantially circular cross-section in the expanded deployed configuration, but in addition the cell patterns of the inflow and outflow sections permit those sections to adapt to the specific anatomy of the patient, thereby reducing the risk of migration and reducing the risk of perivalvular leaks. The cell patterns employed in the constriction region are selected to provide a uniform circular cross-section area for the constriction region when deployed, and a pre-determined radius of curvature for the transition between the constriction region and outflow section of the frame. In particular, the convex-concave shape of frame 12 within the constriction region ensures that the frame is held away from the opposing sinus wall in the ascending aorta, thus ensuring adequate blood flow to the coronary arteries and facilitating catheter access to the coronary arteries.

Enlarged outflow section has nominal deployed diameter D_o , inflow section has nominal deployed diameter D_I , and constriction region has deployed substantially fixed diameter D_c . The conical shape of the inflow region and smooth transitions between adjacent sections of frame 12 are expected to be particularly advantageous in directing blood flow through the valve body with little or no turbulence, as compared to step changes in

diameter observed for surgically implanted replacement valves.

The above-described cell pattern permits each of the inflow and outflow sections of frame 12 to expand to a diameter within a range of deployed diameters, while retaining constriction region 17 at a substantially constant diameter. Thus, for example, outflow diameter D_o may range from 30 to 55 mm, while inflow diameter D_I may vary from 19 to 34 mm. Illustratively, frame 12 may be manufactured in four sizes having a range of diameters D_o , D_I and D_c as set forth in Table 1 below:

Table 1

	Size A	Size B	Size C	Size D
D_o	40 mm	50 mm	40 mm	50 mm
D_c	22 mm	22 mm	24 mm	24 mm
D_I	26 mm	26 mm	29 mm	29 mm

Advantageously, these four frame sizes are expected to cover a wide range of patient anatomies, while requiring construction of only two sizes of valve bodies (22 and 24 mm). Compared to previously-known commercially available surgical valves, which vary from approximately 17 mm to 31 mm in one millimeter increments, it is expected that the above four sizes of valve prosthesis of the present invention could be used for more than 75% of the patient population, thus greatly reducing the costs associated with manufacturing and inventorying large numbers of parts.

When configured as a replacement for an aortic valve, inflow section 16 extends into and anchors within the aortic annulus of a patient's left ventricle and

outflow section 15 is positioned in the patient's ascending aorta. Importantly, the configuration of outflow section 15 is expected to provide optimal alignment of the valve body with the direction of blood flow. In addition, the cell pattern of outflow section 15 also serves to anchor the outflow section in the patient's ascending aorta to prevent lateral movement or migration of frame 12. As depicted in FIG. 1C, the use of relatively larger cells in the outflow section of frame 12, combined with the convex-concave shape of constriction region 17, ensures that the frame does not obstruct blood flow to the patient's coronary arteries when deployed and allows for catheter access to the coronary arteries. Frame 12 also may include eyelets for use in loading the heart valve prosthesis 10 into a delivery catheter.

Still referring to FIGS. 1, valve body 14 includes skirt 21 affixed to frame 12, and leaflets 22. Leaflets 22 are attached along their bases to skirt 21, for example, using sutures 23 or a suitable biocompatible adhesive. Adjoining pairs of leaflets are attached to one another at their lateral ends to form commissures 24, with free edges 25 of the leaflets forming coaptation edges that meet in area of coaptation 26.

As depicted in FIG. 1A, the curve formed at joint 27 between the base of each leaflet 22 and skirt 21 follows the contour of the cell pattern of frame 12, so that most of the length of joint 27 is directly supported by frame 12, thereby transmitting forces applied to the valve body directly to the frame. As further depicted in FIG. 1C, commissures 24 are configured to span a cell of frame 12, so that force is evenly distributed within the commissures and to frame 12.

Referring to FIG. 2, valve prosthesis 10 is shown in the contracted delivery configuration. In this state, valve prosthesis may be loaded into a catheter for percutaneous transluminal delivery via a femoral artery and the descending aorta to a patient's aortic valve. In accordance with one aspect of the present invention, commissures 24 are disposed longitudinally offset from coaptation edges 25 of the valve body, thereby permitting a smaller delivery profile than achievable with previously-known replacement valves. In addition, because frame 12 self-expands upon being released from the delivery catheter, there is no need to use a balloon catheter during placement of valve prosthesis 10, thereby avoiding the potential for inflicting compressive injury to the valve leaflets during inflation of the balloon.

Referring now to FIGS. 3A and 3B, skirt 21 and leaflet 22 of a preferred aortic valve embodiment of the present invention are described. In one preferred embodiment, skirt 21 and leaflet 22 are cut from a sheet of animal pericardial tissue, such as porcine pericardial tissue, either manually or using a die or laser cutting system. The pericardial tissue may be processed in accordance with tissue processing techniques that are per se known in the art for forming and treating tissue valve material. In a preferred embodiment, skirt 21 and leaflets 22 have a thickness of between 0.008" and 0.016", and more preferably between 0.012" and 0.014".

In an alternative preferred embodiment, leaflets 22 are formed from animal pericardial tissue as described above, while skirt 21 is cut from a sheet of synthetic or polymer material, such as Dacron, ePTFE, or other similar material as known in the art. In this case, skirt 21 has a thickness of between 0.004" and

0.012", and more preferably between 0.006" and 0.008", and may thus be compressed to a substantially smaller delivery profile. Alternatively, skirt 21 and leaflets 22 may be constructed of a synthetic or polymeric material.

5 Leaflet 22 includes enlarged lateral ends 30 and 31 disposed at either end of free edge 32, and body 33. Free edge 32 forms coaptation edge 25 of the finished valve body 14, while lateral ends 30 and 31 are folded and joined to adjacent leaflets to form
10 commissures 24. In accordance with one aspect of the present invention, free edges 32 assume the form of catenaries when the valve body is affixed to frame 12, thereby providing uniform loading along the length of the coaptation edge in a manner similar to a suspension
15 bridge. Body 33 is joined to skirt 21 as described below. Lateral ends 30 and 31 illustratively are shown in FIG. 3A as having fold lines **d**, **e** and **f**, to define flaps 34, 35 and 36.

 In the embodiment of FIG. 3B, skirt 21 includes
20 panels 21a, 21b and 21c, each panel having scalloped area 37, reinforcing tab 38, and end tab 39. Scalloped area 37 or each panel 21a, 21b and 21c is joined to a body 33 of a respective leaflet 22. Reinforcing tabs 38
illustratively include fold lines **g**, **h** and **i**, between
25 panels 21a-21b and 21b-21c, except for reinforcing tabs 40 and 41 at the lateral ends of the panels 21a and 21c, which have only one fold apiece. As described below, reinforcing tabs 40 and 41 are joined to one another, e.g., by sutures or gluing, so that skirt 21 forms a
30 frustum of a cone. In one preferred embodiment, panels 21a, 21b and 21c are cut conjoined from a single piece of animal pericardium, as depicted in FIG. 3B.

End tabs 39 are folded over the ends of the proximal-most row of cells of frame 12 to secure skirt 21 to the frame and seal against perivalvular bypass flows (see FIG. 1A). Because end tabs 39 are directly supported by the last zig-zag row of cells of frame 12, there is no opportunity for an unsupported edge of the skirt to flap or otherwise extend into the flow path along the inflow edge of skirt 21. Thus, the design of the valve prosthesis not only ensures that there are no flaps to disrupt flow or serve as sites for thrombus formation, but also reduces the risk that hemodynamic flow against such flaps could cause frame 12 to migrate.

It has been observed that when panels 21a-21c are cut conjoined from a single piece of animal pericardium, the skirt has a tendency to bunch-up or "accordion" when the valve body is collapsed to its reduced delivery configuration. However, applicants have discovered that if panels 21a-21c are severed along fold lines **h** in FIG. 3B, or individually cut from a piece of animal pericardium, this phenomenon is not observed, and the skirt can be collapsed to a substantially smaller profile. In particular, whereas a tissue-based skirt comprising conjoined panels 21a-21c, as shown in FIG. 3B, fits within a 21 French delivery catheter, forming skirt 21 of individual panels 21a-21c enables the device to fit within an 18 French catheter, resulting in a reduction in the delivery profile of about twenty-five percent (25%).

As a still further alternative, skirt 21 may be formed of a synthetic or polymeric material, such as Dacron, ePTFE, or similar material selected for its properties and biocompatibility. As opposed to leaflets 22, which provide a mechanical function through movement, skirt 21 functions primarily to create a seal to prevent

perivalvular leaks. Accordingly, a thin synthetic material may be used in place of thicker mammalian tissue to serve this purpose. As a result, the device may be compacted to a reduced delivery profile by virtue of the decreased volume of the skirt. For example, use of a synthetic skirt with a valve body having tissue-based leaflets may enable the device to fit within a catheter having even less than an 18 French diameter.

Referring to FIGS. 4A and 4B, assembly of valve body 14 from the above-described embodiments of skirt 21 and leaflets 22 is described. In FIG. 4A, flap 34 first is folded along line **d**. Flap 35 is folded along line **e** so that it lies atop flap 34, forming seam 42 comprising a triple thickness of the tissue. Flap 36 then is folded along line **f**. Adjoining leaflets 22 then are fastened together along adjacent seams 42, resulting in a leaflet assembly.

Reinforcing tabs 38 are folded along lines **g**, **h** and **i** to form seams 43 comprising a double thickness of tissue, or in the case of separate panels 21a-21c, joined to form seams along tabs 38. Next, the leaflet assembly is attached to skirt 21 along the bottom edges of bodies 33 of the leaflets to form joints 44. At this stage of the assembly, prior to attaching reinforcing tab 40 to 41 and the remaining seam 42 of leaflets 22, the valve body appears as depicted in FIG. 4B. Reinforcing tabs 40 and 41 then are fastened together to form another seam 43 along skirt 21 and the remaining seam 42 between leaflets 22. Valve body 14 then is ready to be affixed to frame 12.

Referring to FIG. 4C, alternative embodiment of a synthetic skirt for a valve body of the present invention is described. Skirt 45 of FIG. 4C is formed

from tube 47 of commercially available synthetic material, such as described above. Tube 47 is cut at one end to form scalloped areas 37, while notches are cut at the other end of the tube to form end tabs 39. Leaflets 22, which may comprise natural or synthetic material, then are assembled and attached to skirt 45 in a manner similar to that described above. Because skirt 45 is essentially cylindrical, it preferably comprises a material that is sufficiently flexible to stretch to conform to the desired shape of frame when end tabs 39 are attached to frame 12.

In FIG. 4D, another alternative embodiment of a synthetic skirt for a valve body of the present invention is described. In this case, the skirt first is cut from tube 47 into a shape shown in FIG. 4C, and then formed into a shape resembling the frustum of a cone by creating triangular pleats 48. In particular, prior to the attachment of a leaflet assembly, the apices of the scalloped areas 37 are folded upon themselves and joined, such as by sewing, bonding, welding, molding, or gluing together to form pleats 48. As illustrated in FIG. 4D, pleats 48 may be formed by seams 49, and may have a width selected to impart any desired amount of taper to the skirt 46. The leaflets then may be assembled and attached to the skirt, and the valve body attached to frame 12, as described above. Advantageously, pleats 48 provides strengthened attachment points to secure skirt 46 to frame 12.

Referring to FIG. 5, valve body 14 is shown as it would appear when affixed to frame 12, but with frame 12 omitted to better illustrate where the valve body is affixed to the frame. During the step of affixing the valve body to the frame, flaps 36 of adjacent leaflets

are affixed, e.g., by sutures, to span a cell of the frame to support commissures 24 (compare to FIG. 1B) and end tabs 39 are folded over and affixed to the proximal-most row of cells of the frame 12 (compare to FIG. 1A).

5 Valve body 14 also is attached to frame 12 along seams 43 formed by the reinforcing tabs. Each joint 44 is aligned with and fastened to (e.g., by sutures or glue) to a curved contour defined by the struts of the cells of frame 12, so that joint 44 is affixed to and supported by
10 frame 12 over most of the length of the joint. As discussed above, the configuration of the cells in frame 12 may be specifically customized define a curved contour that supports joints 44 of the valve body.

When completed assembled to frame 12, valve
15 body 14 is affixed to frame 12 along the edges of flaps 36 of the commissures, end tabs 39, leaflet seams 42, reinforcing tab seams 43 and joints 44. In this manner, forces imposed on leaflets 22, commissures 24 and joints 44 are efficiently and evenly distributed over the valve
20 body and transferred to frame 12, thus reducing stress concentration and fatigue of the valve body components. Moreover, the use of multiple thicknesses of material along seams 42 and 43 is expected to provide a highly durable valve body that will last for many years once
25 implanted in a patient.

In accordance with another aspect of the present invention, the center of coaptation of leaflets 22 is a distance L below the point at which the commissures are affixed to the frame, as shown in FIG. 5.
30 Compared to previously-known designs, in the present invention the overall lengths of the coaptation edges are increased, while leaflets 22 coapt along a shorter

portion of those lengths. Several advantages arise from this design:

- the leaflets require only minimal pressure to open and have a rapid closing time.
- 5 • the valve demonstrates better washing dynamics when open, i.e., less turbulence along the free edges of the leaflets.
- the valve provides a more uniform distribution of stresses along the coaptation edges of leaflets 22.
- 10 • the angle at which force is transmitted to the commissures is increased, thereby substantially reducing the horizontal forces applied to the commissures that tend to pull the commissures away from the frame.
- controlling the center of the height of
- 15 coaptation allows the commissures to be located proximal of the center of coaptation, thereby reducing the contracted delivery profile of the valve prosthesis.

All of the foregoing benefits are expected to reduce non-uniform loads applied to the valve body, and

20 substantially enhance the durability of the valve prosthesis.

As will of course be apparent to one of skill in the art of prosthetic valve design, the assembly steps described above are merely illustrative, and a different

25 order of assembling the leaflets and skirt to form valve body 14 may be employed. In an alternative embodiment, a conventional sewing ring may be attached to valve body 14 and frame 12 may be omitted. In this case, the valve prosthesis may be implanted surgically, rather than by

30 percutaneous transluminal delivery. In this case, commissures 24 may be attached to the ascending aorta by sutures or other means as described above.

Referring now to FIG. 6, implantation of valve prosthesis 10 of the present invention is described and is shown having skirt 46 from FIG. 4D. As discussed above, valve prosthesis preferably comprises a self-expanding multilevel frame that may be compressed to a contracted delivery configuration, as depicted in FIG. 3, onto an inner member of a delivery catheter. The valve prosthesis and inner member may then be loaded into a delivery sheath of conventional design, e.g., having a diameter of 18-20 French or less. Due in part to the fact that commissures 24 are longitudinally offset from the coaptation edges of the leaflets, the ability to customize the cell pattern along the length of the frame, and the construction of the skirt, it is expected that valve prosthesis may be designed to achieve a significantly smaller delivery profile than previously-known percutaneously-deliverable replacement valves.

The delivery catheter and valve prosthesis are then advanced in a retrograde manner through a cut-down to the femoral artery and into the patient's descending aorta. The catheter then is advanced, under fluoroscopic guidance, over the aortic arch, through the ascending aorta and mid-way across the defective aortic valve. Once positioning of the catheter is confirmed, the sheath of the delivery catheter may be withdrawn proximally, thereby permitting the valve prosthesis to self-expand.

As the valve prosthesis expands, it traps native leaflets **LN** of the patient's defective aortic valve against the valve annulus, retaining the native valve in a permanently open state. As further illustrated in FIG. 6, outflow section 15 of the valve prosthesis expands against, and aligns the prosthesis within, the ascending aorta, while inflow section 16

becomes anchored in the aortic annulus of the left ventricle, so that skirt 21 reduces the risk of perivalvular leaks.

As also seen in FIG. 6, the deployed configuration of constriction region 17 holds valve body 14 in a supra-annular position, away from the heart walls, thereby ensuring that the constriction region expands to the predetermined fixed diameter. This in turn ensures that the valve body does not experience any unexpected lateral loads and therefore expands to its design diameter, e.g., illustratively either 22 or 24 mm as in Table 1 above.

Because outflow section 15 of frame 12 employs relatively larger cells than the remainder of the frame, valve prosthesis 10 does not disrupt blood flow into coronary arteries **CA** when deployed, and also does not obstruct subsequent catheter access to the coronary arteries. Accordingly, a clinician may readily gain access to the coronary arteries, for example, to perform angioplasty or stenting, simply by directing the angioplasty or stent delivery system guide wire through the openings in the cell pattern of frame 12.

While preferred embodiments of the invention are described above, it will be apparent to one skilled in the art that various changes and modifications may be made. The appended claims are intended to cover all such changes and modifications that fall within the true spirit and scope of the invention.

What Is Claimed Is:

1. A valve prosthesis comprising:
a self-expanding multi-level frame having a contracted delivery configuration and an expanded deployed configuration, the multi-level frame having in the expanded deployed configuration an enlarged outflow section with a first nominal diameter, a conical inflow section having a second nominal diameter and a constriction region having a third fixed diameter smaller than the first and second nominal diameters; and
a valve body affixed to the multi-level frame, the valve body comprising a plurality of leaflets affixed to a skirt.
2. The valve prosthesis of claim 1 wherein the multi-level frame comprises a cell pattern defined by unequal length zig-zags.
3. The valve prosthesis of claim 1 wherein the conical section has a proximal end and the conical inflow section flares outward towards the proximal end.
4. The valve prosthesis of claim 1 wherein adjoining leaflets are affixed together to form commissures and have free edges that define coaptation edges and a center of coaptation, the commissures being longitudinally offset from the center of coaptation.
5. The valve prosthesis of claim 4 wherein the commissures are affixed to the multi-level frame at a location proximal of the center of coaptation.

6. The valve prosthesis of claim 5 wherein the multi-level frame comprises a cell pattern and the commissures include flaps that span an entire area of at least one cell of the cell pattern.

7. The valve prosthesis of claim 4 wherein the commissures and coaptation edges of the leaflets define catenaries that substantially uniformly distribute loads over the leaflets.

8. The valve prosthesis of claim 7 wherein the catenaries are configured to reduce horizontal loads applied to the commissures.

9. The valve prosthesis of claim 1 wherein the leaflets are affixed to the skirt at joints, and the joints are affixed to the frame to evenly distribute forces through the valve body to the multi-level frame.

10. The valve prosthesis of claim 9 wherein the multi-level frame further comprises a cell pattern that defines a contour configured to support the joints.

11. The valve prosthesis of claim 4 wherein each leaflet is individually formed and comprises an enlarged lateral end having a plurality of flaps that are folded over to increase the durability of the commissures.

12. The valve prosthesis of claim 1 wherein the skirt further comprises a plurality of longitudinally-oriented reinforcing tabs or pleats.

13. The valve prosthesis of claim 12 wherein the reinforcing tabs or pleats are affixed to the multi-level frame.

14. The valve prosthesis of claim 12 wherein the skirt further comprises a plurality of end tabs adapted to be affixed to a proximal-most row of cells of the multi-level frame.

15. The valve prosthesis of claim 1 wherein the leaflets comprise a material selected from one of: porcine, bovine, equine or other mammalian pericardial tissue, synthetic material or polymeric material.

16. The valve prosthesis of claim 1 wherein the valve body is deployed supra-annularly of a patient's aortic annulus when the valve prosthesis is delivered within a patient's aortic valve and the multi-level frame is in the expanded deployed configuration.

17. The valve prosthesis of claim 1 wherein the multi-level frame is configured to hold a patient's native valve permanently open in the expanded deployed configuration.

18. The valve prosthesis of claim 1 wherein the multi-level frame is configured to permit access to a patient's coronary arteries in the expanded deployed configuration.

19. The valve prosthesis of claim 1 wherein multi-level frame has proximal and distal ends and a plurality of cell patterns that vary in size between the proximal and distal ends.

20. The valve prosthesis of claim 1 wherein the constriction region comprises a plurality of cell patterns configured to provide a pre-determined radius of curvature for a transition from the constriction region to the outflow section.

21. The valve prosthesis of claim 1 wherein the skirt comprises a synthetic material.

22. The valve prosthesis of claim 21 wherein the skirt has a tubular shape in an undeformed configuration.

23. The valve prosthesis of claim 22 wherein skirt is configured in conical frustum shape formed by deforming the synthetic material.

24. The valve prosthesis of claim 23 wherein the conical frustum shape is formed by creating a plurality of longitudinally-oriented pleats in the synthetic material.

25. The valve prosthesis of claim 1 wherein the skirt comprises two or more individual panels of animal pericardial material.

26. The valve prosthesis of claim 1 wherein the skirt comprises two or more conjoined panels of animal pericardial material.

27. A valve prosthesis comprising:

a valve body comprising a plurality of leaflets affixed to a skirt, adjoining leaflets affixed together to form commissures and having free edges that define coaptation edges and a center of coaptation,

wherein the commissures are longitudinally offset from the center of coaptation and define catenaries that substantially uniformly distribute loads over the leaflets.

28. The valve prosthesis of claim 27 wherein the catenaries are configured to reduce horizontal loads applied to the commissures.

29. The valve prosthesis of claim 27 wherein each leaflet is individually formed and comprises an enlarged lateral end having a plurality of flaps that are folded over to increase the durability of the commissures.

30. The valve prosthesis of claim 27 wherein the skirt further comprises a plurality of longitudinally-oriented reinforcing tabs or pleats.

31. The valve prosthesis of claim 27 wherein the leaflets comprise a material selected from one of: porcine, bovine, equine or other mammalian pericardial tissue, synthetic material or polymeric material.

32. The valve prosthesis of claim 27 wherein the valve prosthesis further comprises a self-expanding frame, the leaflets are affixed to the skirt at joints, and the joints are affixed to the frame to evenly distribute forces through the valve body to the frame.

33. The valve prosthesis of claim 32 wherein the frame further comprises a cell pattern that defines a contour configured to support the joints.

34. The valve prosthesis of claim 30 wherein the valve prosthesis further comprises a self-expanding frame and the reinforcing tabs or pleats are affixed to the frame.

35. The valve prosthesis of claim 27 further comprising a self-expanding frame having a contracted delivery configuration and an expanded deployed configuration.

36. The valve prosthesis of claim 35 wherein the frame comprises a cell pattern defined by unequal length zig-zags.

37. The valve prosthesis of claim 35 wherein the commissures are affixed to the frame at a location proximal of the center of coaptation.

38. The valve prosthesis of claim 35 wherein the frame comprises a cell pattern and the commissures include flaps that span an entire area of at least one cell of the cell pattern.

39. The valve prosthesis of claim 35 wherein the skirt further comprises a plurality of end tabs adapted to be affixed to a proximal-most row of cells of the frame.

40. The valve prosthesis of claim 35 wherein the valve body is deployed supra-annularly of a patient's aortic annulus when the valve prosthesis is delivered within a patient's aortic valve and the frame is in the expanded deployed configuration.

41. The valve prosthesis of claim 35 wherein the frame is configured to hold a patient's native valve permanently open in the expanded deployed configuration.

42. The valve prosthesis of claim 35 wherein the frame is configured to permit access to a patient's coronary arteries in the expanded deployed configuration.

43. The valve prosthesis of claim 35 wherein frame has proximal and distal ends and a plurality of cell patterns that vary in size between the proximal and distal ends.

44. The valve prosthesis of claim 35 wherein the frame has, in the expanded deployed configuration, an enlarged outflow section with a first nominal diameter, a conical inflow section having a second nominal diameter and a constriction region having a third fixed diameter smaller than the first and second nominal diameters.

45. The valve prosthesis of claim 44 wherein the conical section has a proximal end and the conical section flares outward towards the proximal end.

46. The valve prosthesis of claim 44 wherein the constriction region comprises a plurality of cell patterns configured to provide a pre-determined radius of curvature for a transition from the constricted region to the outflow section.

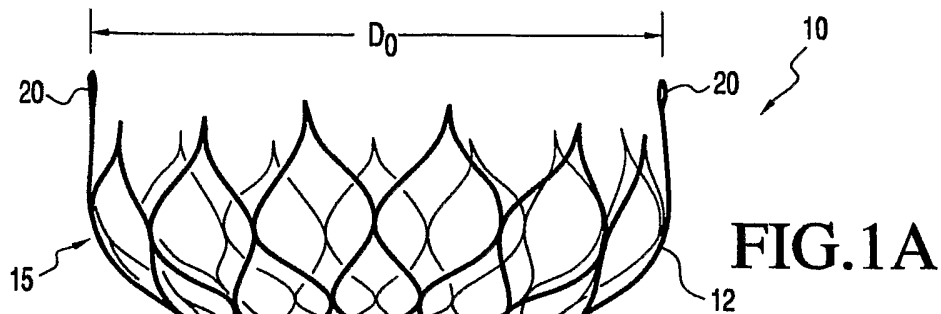

FIG. 1A

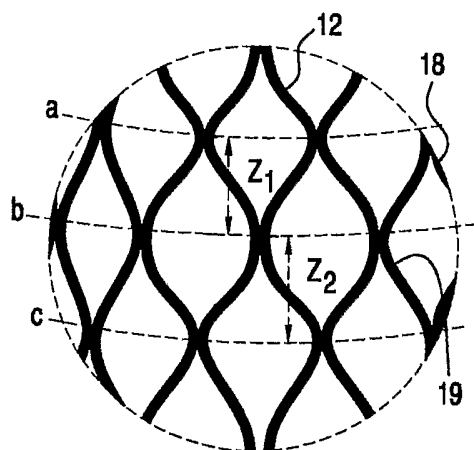

FIG. 1B

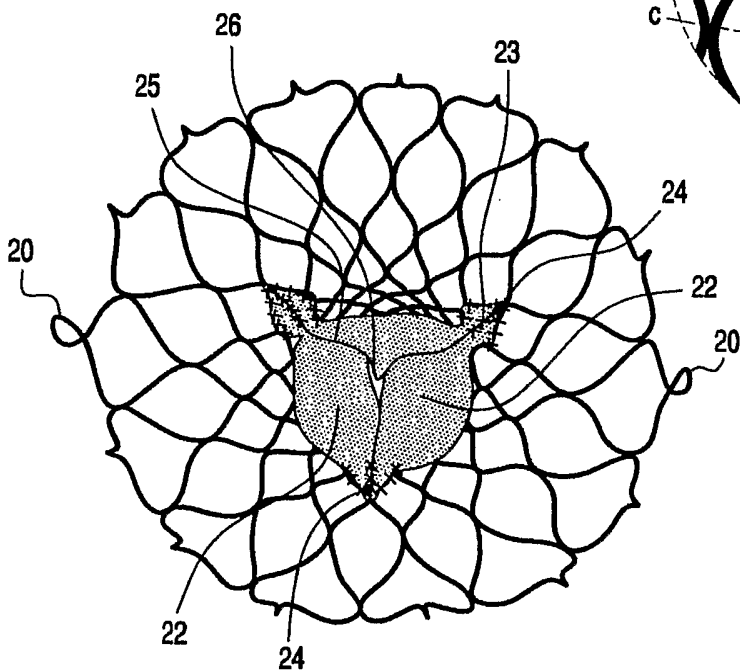

FIG. 1C

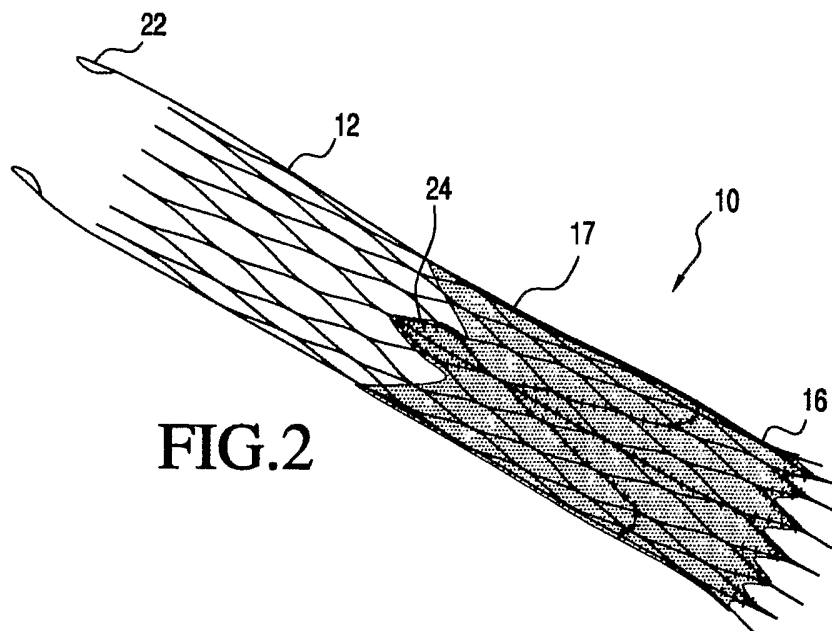

FIG. 2

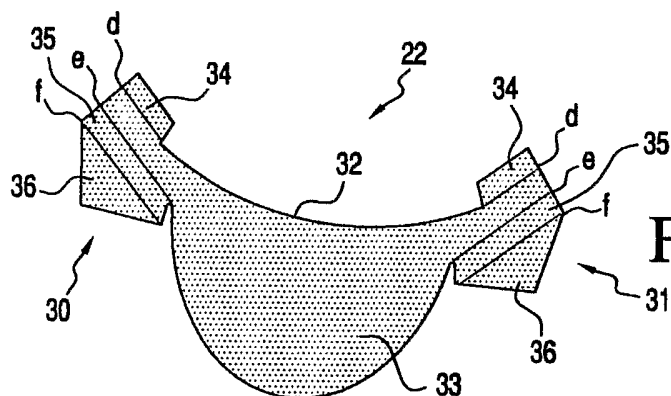

FIG. 3A

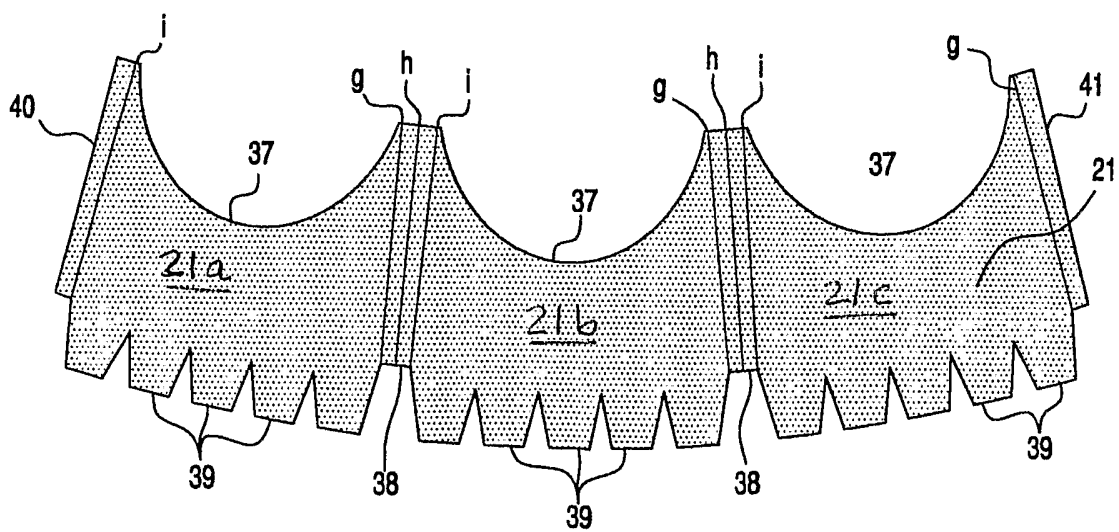

FIG. 3B

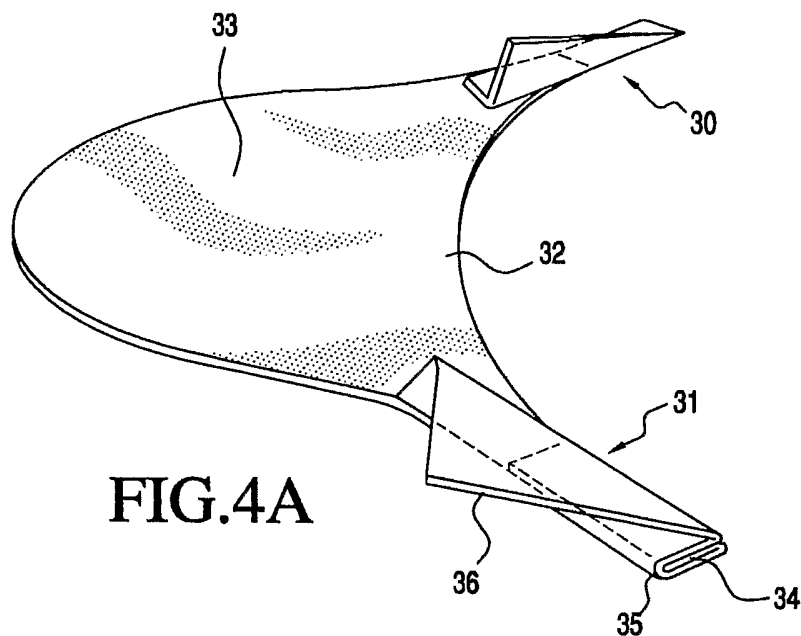

FIG. 4A

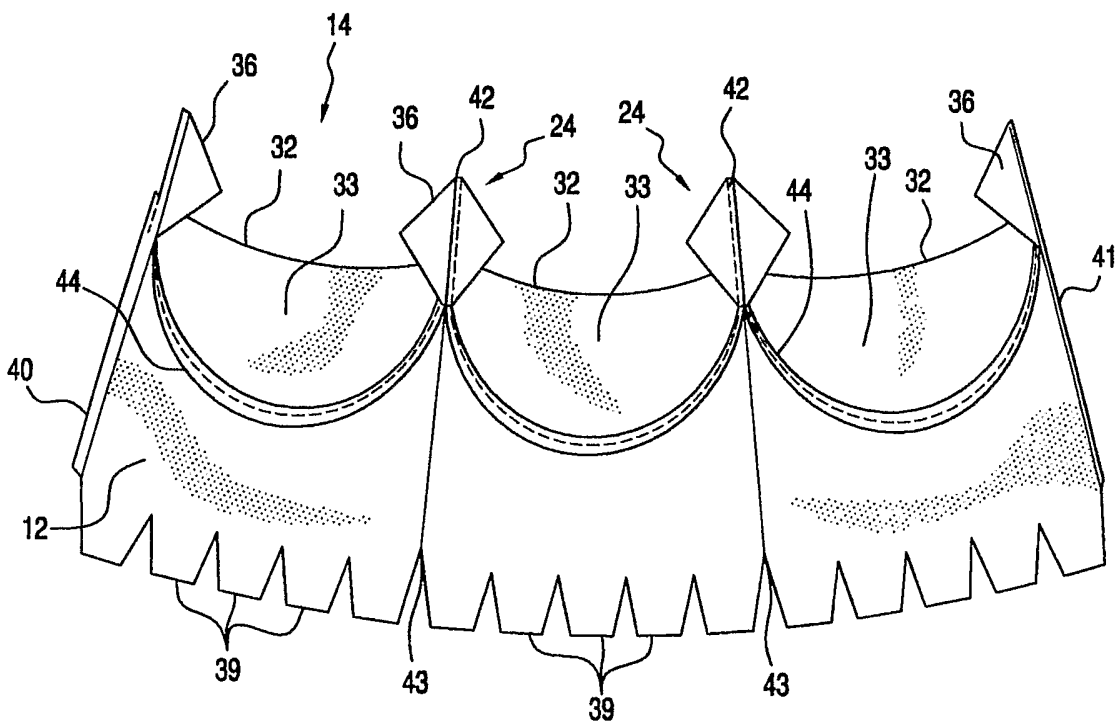

FIG. 4B

4/5

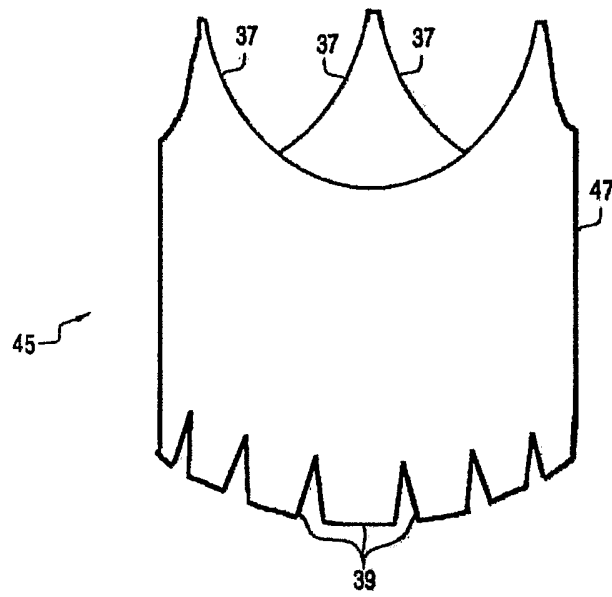

FIG. 4C

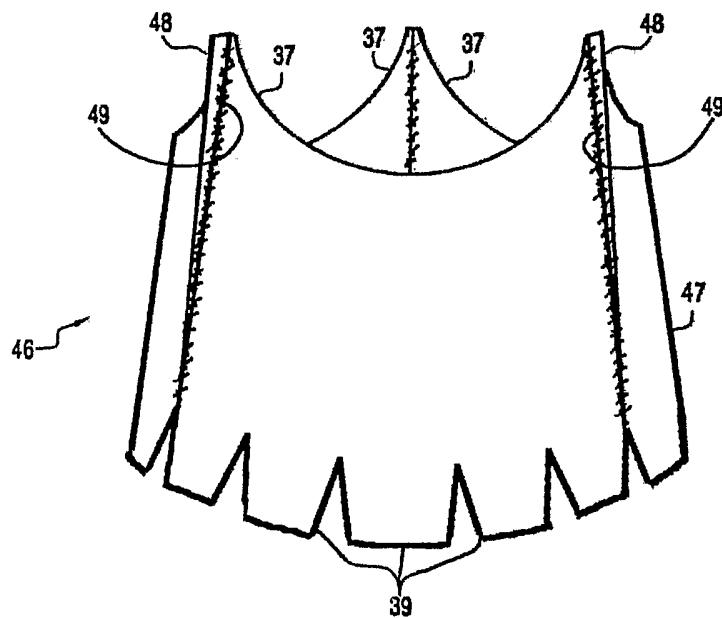

FIG. 4D

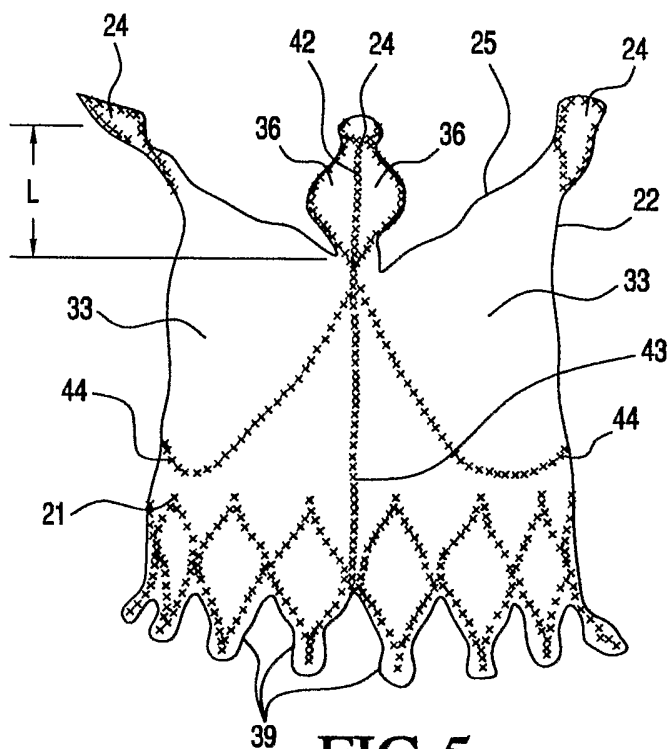

FIG. 5

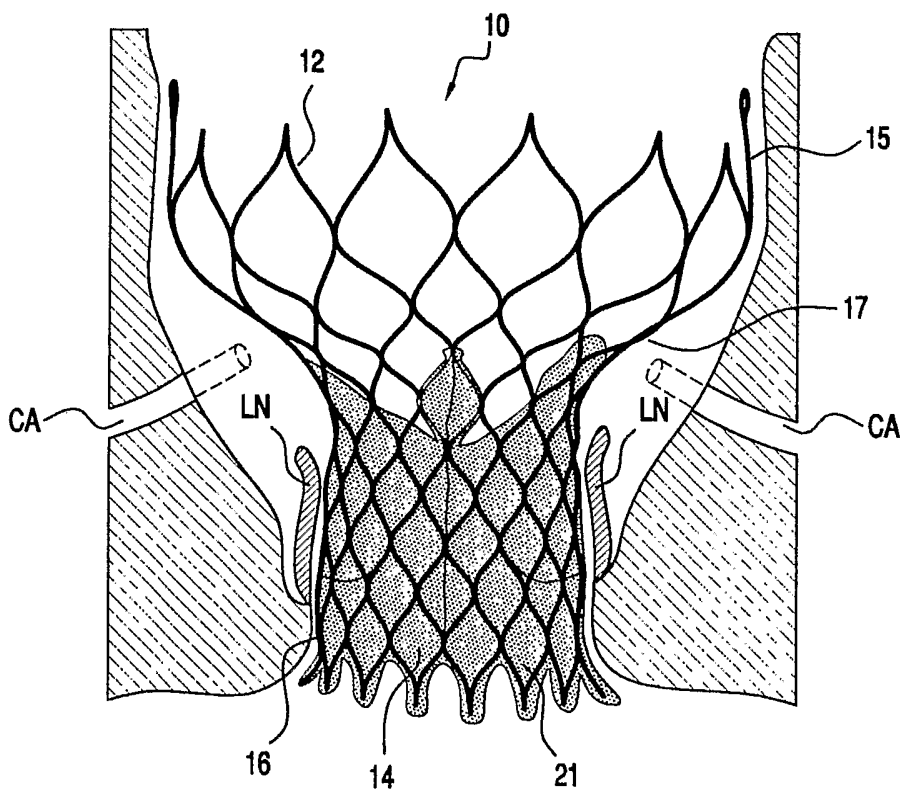

FIG. 6