

Feb. 2, 1960

T. P. PAJAK

2,923,902

FLEXIBLE WAVE GUIDE

Filed Sept. 26, 1957

Fig. 1.

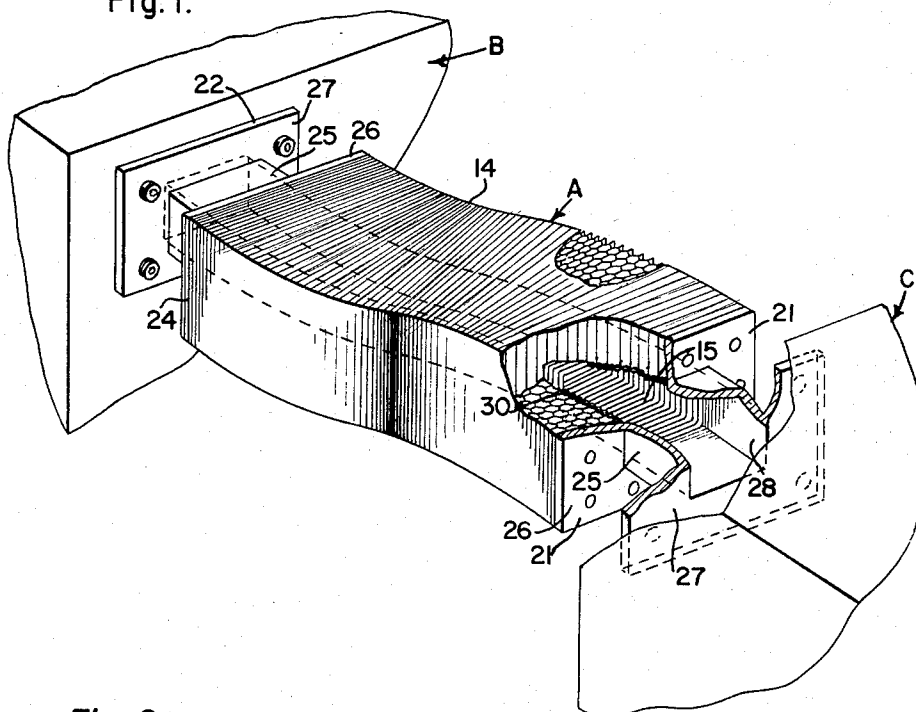
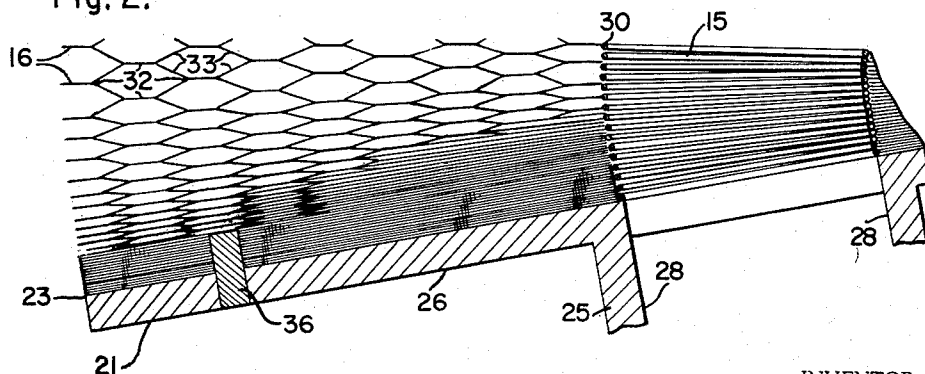

Fig. 2.



INVENTOR.  
Theodore P. Pajak

BY  
*Townsend and Townsend*  
Attorneys

1

2

2,923,902

**FLEXIBLE WAVE GUIDE**

Theodore P. Pajak, Bel Air, Md., assignor to Hexcel Products Inc., Oakland, Calif., a corporation of California

Application September 26, 1957, Serial No. 686,481

6 Claims. (Cl. 333—95)

This invention relates to a wave guide for the transmission of electromagnetic signals of the higher frequency ranges.

The conventional wave guide structure comprises a rectangular conduit formed of a conductive material to provide an air passageway of predetermined dimension through which electromagnetic waves within particular wave lengths in the higher frequency ranges may pass with great efficiency. In that the conventional wave guide structure is formed of solid metal such as aluminum, it is usually necessary to preform each wave guide structure to rather precise mechanical dimensions in order to provide the mechanical connections of the wave guide between two pieces of electronic gear. There is another form of wave guide known in a prior art that employs a conduit formed of overlapping layers of sheet metal, each layer being slidably disposed with respect to the other so as to impart to the wave guide structure a certain amount of flexibility. In such structure the outside is encased in a flexible material such as rubber or plastic so that the various layers of sheet metal are held together by the outside resilient or flexible coating. This form of wave guide is costly and is limited in the degree of angle it may be flexed.

A principal object of this invention is to provide a novel wave guide structure adapted to have a great amount of flexibility. The novel wave guide is formed of unexpanded metal honeycomb core of the type described in U.S. Patents 2,756,496 to K. M. Holland and 2,734,843 to R. C. Steele, et al. and is arranged to obtain flexibility upon the honeycomb being partially expanded.

A feature and advantage of this invention is that the wave guide structure of this invention may be fabricated with great economy by forming the guides from the waste or end pieces cut from larger sheets of honeycomb. Such scraps or waste pieces are frequently in abundance where honeycomb is manufactured.

Another object of this invention is to provide a wave guide formed of a plurality of sheets of material lying face to face and with the longitudinal axis of the wave guide chamber formed at right angles to the faces of the sheet material forming the structure. In this structure each of the sheets are attached one to the other along parallel spaced lines so the sheets may be bent or deformed between the attaching lines without the necessity of providing an exterior structural support, such as a flexible sheath or sleeve to hold the various sheets of metal together.

Another object of this invention is to provide a simple and economical wave guide structure having the characteristic of being readily deformed by twisting, bending or stretching so that the effective length of the wave guide may be increased and the two opposite ends can be positioned at substantially different angles and planes without substantially changing the transmission characteristics of the wave guide.

Other objects of the present invention will become apparent upon reading the following specification and re-

ferring to the accompanying drawings in which similar characters of reference represent corresponding parts in each of the several views.

In the drawings:

5 Fig. 1 is a perspective view of the novel wave guide forming a link between two pieces of electronic gear. A portion of the wave guide is cut away to show the inner structure thereof.

Fig. 2 is an enlarged partial section of Fig. 1.

10 In Figs. 1 and 2 the wave guide of this invention is generally indicated at A and is shown connected to two pieces of electronic equipment B and C to provide a tuned path between the two pieces of equipment for high efficiency transmission of electromagnetic waves of a predetermined frequency band. Wave guide A comprises a main body formed of a block 14 of metal sheets 16 joined together to form unexpanded honeycomb material and two mounting brackets 21 and 22 on each end of the block to provide means to mount the guide on appropriate electronic equipment.

25 Brackets 21 and 22 are mounted on the outer of sheets 16 as indicated at 23 and 24 respectively. Each bracket comprises a neck 25 formed with a collar 26 integral one end of the neck which is attached to block 14 and a collar 27 integral the opposite end of the neck to mount the bracket on electronic equipment.

30 Block 14 is formed with a rectangular tuned chamber 15 with the longitudinal axis of the chamber disposed normal to the broad faces of the individual sheets 16 which form the honeycomb material. Necks 25 are similarly formed with tuned wave guide throats 28 axially aligned with chamber 15.

35 In the preferred embodiment of the invention chamber 15 is formed by first cutting the chamber slightly larger than necessary to meet dimension necessary for the desired tuned range and thereafter a rectangular helical coil of wire as indicated at 30 is mounted on the walls of chamber 15. The thickness of the wire is thereby arranged to form the walls of chamber 15 with the proper dimension for desired resonance. Wire 30 provides regular walls for wave guide when the block is bent, twisted or stretched and thereby functions to minimize loss during operation.

45 The dimension of the opening forming the wave guide is determined by the frequency range that is to be transmitted through the guide. For example, for the X band, otherwise known as "RG 59" (Armed Service designation), which is in the frequency range of 8.2 to 12.4 kilomegacycles, the chamber would be .4 in. high and .9 in. in width. For the other frequency ranges appropriate changes in dimension are indicated.

55 The honeycomb cellular structure forming block 14 may be made as described in U.S. Letters Patent No. 2,756,496 and No. 2,734,843. The cellular structure is generally formed by applying to opposite sides of an elongated web or sheet of material alternately spaced or staggered glue lines, then superposing and adhering to one another layers of said web into an unexpanded stock or block of honeycomb. A stack thus formed may be sliced transversely to the glue lines to form one or more smaller slices or sections of unexpanded honeycomb. As viewed in Fig. 2 the various sheets 16, illustrated by single lines in the drawings for convenience of illustration, are glued together along adhesive lines indicated at 32. The areas of the sheets between the glue lines, as indicated at 33, are bendable so the structure is adaptable to be deformed by bending, axial twisting and/or expansion of the unexpanded or partially expanded section.

70 It has been found desirable to bond several sheets 16 adjacent the respective two end sheets 23 and 24 together to form a stronger bond between the brackets and

3

the block. To bond the sheets together a hole or aperture as indicated at 36 is drilled through collars 26 and the adjacent several sheets 16. Hole 36 is subsequently filled with glue. By this means the end group of sheets on both ends of the wave guide are prevented from being expanded thus adding substantially more rigidity to the structure and thereby preventing the face sheet 23 or 24 from being torn loose from the remainder of the honeycomb's structure.

Although the foregoing invention has been described in some detail by way of illustration and example for purposes of clarity and of understanding, it is understood that certain changes and modifications may be practiced within the spirit of the invention as limited only by the scope of the claims. It is to be further understood that the term "unexpanded honeycomb" shall mean that type of material as described in U.S. Patent No. 2,756,496 and No. 2,734,843. However, it is also to be understood that this does not limit the honeycomb material as precisely described in the aforesaid patent references but rather indicates the general type core material in which various sheets of metal material are bonded together to form a cellular structure when expanded.

What is claimed is:

1. A wave guide comprising an unexpanded honeycomb block formed of flexible sheets of conductive material bonded together so the sheets deform to form a cellular structure in the expanded condition, said block being formed with a chamber of substantially rectangular configuration in cross-section formed to be tuned for the transmission of energy of a predetermined wave length therethrough, and the longitudinal axis of said chamber being normal to the broad faces of the sheets forming the honeycomb material whereby upon partially expanding the block the block may be longitudinally lengthened, axially twisted and bent transversely to the longitudinal axis of the block.

2. A wave guide comprising an unexpanded honeycomb block formed of flexible sheets or conductive material bonded together so as to deform to form a cellular structure in the expanded condition, said block being

4

formed with a chamber of substantially rectangular configuration in cross-section formed to be tuned for the transmission of energy of a predetermined wave length therethrough, the longitudinal axis of said chamber being normal to the broad faces of the sheets forming the honeycomb material, bracket means mounted on the two outside sheets of material forming the block, and said bracket means formed with tuned throats axially aligned with the chamber formed in said block.

3. A device according to claim 2 and wherein the chamber formed in said block is lined with a helical wire.

4. A device according to claim 2 and wherein a plurality of sheets of material forming the honeycomb block adjacent at least one of the two outside sheets are bonded together to prevent expansion thereof.

5. A device according to claim 2 and wherein a plurality of sheets of material forming the honeycomb block adjacent at least one of the two outside sheets are apertured, and glue in the apertures to bond the apertured sheets together and prevent expansion thereof.

6. A wave guide comprising a block formed of conductive sheets joined together by an adhesive material along spaced lines wherein the lines on opposite sides of each sheet are interposed with respect to each other; said block being expandable in the direction of its lengthwise axis, axially twistable, and bendable transversely to the longitudinal axis of said block; said block being formed with a chamber of substantially rectangular configuration in cross-section formed to be tuned for the transmission of energy of a predetermined wave length therethrough; the longitudinal axis of said chamber being normal to the broad faces of the sheets forming the block.

References Cited in the file of this patent

UNITED STATES PATENTS

2,756,496 Holland \_\_\_\_\_ July 31, 1956

OTHER REFERENCES

Publication: Electronics, vol. 29, No. 12, December 1956 (Markus) pages 228 and 230.