

661402

P/00/001
Section 29
P/00/008
Section 29(1)
Regulation 3.1(2)

AUSTRALIA
Patents Act 1990
PATENT REQUEST AND NOTICE OF ENTITLEMENT

We LABORATORIOS CUSI, S.A.

of Ctra. Francia, S/No. 08320 El Masnou, BARCELONA, SPAIN

being the Applicant and Nominated Person, request the grant of a patent for an invention entitled PHARMACEUTICAL PRODUCT CONTAINER WITH TWO SEPARATE SUBSTANCES AND A MIXING DEVICE AND DOSED DISPENSATION which is described in the accompanying standard complete specification.

Convention priority is claimed from the following basic application:

Basic Applicant	Application Number	Application Date	Country	Country Code
Laboratorios Cusi, S.A.	9202278	2 July 1992	Spain	ES
Laboratorios Cusi, S.A.	9300651	30 March 1993	Spain	ES

José Alberto Vallet Mas and Francesc Xavier Gimenez Guasch are the actual inventors of the invention.

The inventors made the invention for and on behalf of the applicant/nominated person in the course of their duties as employees of the applicant/nominated person.

The basic applications were the first applications made in a Convention country in respect of the invention the subject of this request.

Drawing number recommended to accompany the abstract: 1

Our address for service is:

GRIFFITH HACK & CO
168 WALKER STREET
NORTH SYDNEY NSW 2060

Attorney Code:

GH

DATED this 29th day of June 1993

S 038679 300693

LABORATORIOS CUSI, S.A.
By their Patent Attorney



GRIFFITH HACK & CO



AU9341662

(12) PATENT ABRIDGMENT (11) Document No. AU-B-41662/93
(19) AUSTRALIAN PATENT OFFICE (10) Acceptance No. 661402

- (54) Title
PHARMACEUTICAL PRODUCT CONTAINER FOR SEPARATELY HOLDING TWO SUBSTANCES AND HAVING A MIXING DEVICE AND DOSED DISPENSATION MEANS
- International Patent Classification(s)
(51)⁵ **A61J 001/00**
- (21) Application No. : **41662/93** (22) Application Date : **30.06.93**
- (30) Priority Data
- | | | |
|----------------|-----------------|-----------------|
| (31) Number | (32) Date | (33) Country |
| 9202278 | 02.07.92 | ES SPAIN |
| 9300651 | 30.03.93 | ES SPAIN |
- (43) Publication Date : **06.01.94**
- (44) Publication Date of Accepted Application : **20.07.95**
- (71) Applicant(s)
LABORATORIOS CUSI, S.A.
- (72) Inventor(s)
JOSE ALBERTO VALLET MAS; FRANCESC XAVIER GIMENEZ GUASCH
- (74) Attorney or Agent
GRIFFITH HACK & CO. , GPO Box 4164, SYDNEY NSW 2001
- (56) Prior Art Documents
FR 1568362
GB 1403274
US 3802604
- (57) Claim

1. A pharmaceutical product container for separately holding two substances with mixing and dosed dispensation means comprising:

- a first container in which a first one of two substances is receivable, the first container having a retaining flange extending around an opening leading into the inside of the container;

- a second container in which the second one of the two substances is receivable, the second container having a projecting portion terminating in a tearable closure bottom, the projecting portion being receivable in the opening of the first container, a fastening collar surrounding the projecting portion and being provided with an inward retention rib adapted to engage behind the retaining flange of the first container when the projecting portion is received in the first container in an assembled state, and a neck portion with an opening leading into the interior of the second container and

(11) AU-B-41662/93
(10) 661402

-2-

having an exterior thread and a perimeter toothed security flange;

- a cap member having an annular safety seal member severably connected to a main cap portion, the main cap portion being provided with an internal thread to allow screwing of the cap member onto the neck portion of the second container, the safety seal member being provided with perimenterally arranged teeth that are shaped in such a manner that the cap member can be screwed onto the second container a first time permitting the tooth to engage with a toothed security flange of the second container and upon unscrewing prevent rotation of the safety seal member thus separating it from the main cap portion to allow removal thereof; and

- a tubular sleeve member adapted to be received through the opening in the neck portion within the second container in a displaceable manner, the tubular sleeve member having a first terminal portion with a bevelled edge or a pointed longitudinal appendix with decreasing cross-section, the bevelled edge or appendix being adapted to partially tear the closure bottom of the second container upon being axially displaced towards the bottom and pressed against it by the cap member once the safety seal has been removed, and a second terminal portion having an abutment flange from which protrudes a truncated cone-shaped head portion having a dispensing orifice, the abutment flange resting on the neck portion of the second container after tearing of the bottom has been effected, the head portion acting as a drop dispenser for the mixed substances.

AUSTRALIA
Patents Act 1990

66 140 2

ORIGINAL
COMPLETE SPECIFICATION
STANDARD PATENT

Invention Title: PHARMACEUTICAL PRODUCT CONTAINER FOR
SEPARATELY HOLDING TWO SUBSTANCES
AND HAVING A MIXING DEVICE AND DOSED
DISPENSATION MEANS

The following statement is a full description of this invention, including
the best method of performing it known to me/us:

GH&CO REF: P22839-A CAS

PHARMACEUTICAL PRODUCT CONTAINER FOR SEPARATELY HOLDING
TWO SUBSTANCES AND HAVING A MIXING DEVICE AND DOSED
DISPENSATION MEANS

The present invention relates to a product
5 container, more specifically to a pharmaceutical product
container in which two different substances can be stored
separate from one another and which allows mixing and
subsequent dispensation of the mixed substances upon
being required prior to administration of the mixed
10 substances to a patient.

In the pharmaceutical market in general and
especially in the dermic, ophthalmic, otic, oral and
nasal sectors, there are multiple products, such as eye
drops and the like, whose shelf life, once all of the
15 ingredients making up the medical substance have been
mixed, in most cases does not exceed a certain time
period, for example, four weeks.

In view of such circumstances and for some time now,
containers and bottles have been devised in which the
20 ingredients of the medical product are maintained in
separate, independent container sections and which allow
the subsequent mixing of the ingredients prior to their
use.

In most cases, one of the ingredients is a powder,
25 i.e., in lyophilised form, while the other one is in a
liquid state. Each one of the ingredients maintains
individually its stability during a far longer time than
when admixed; the user of the medical substance
himself/herself must then mix both ingredients prior to
30 its administration. The stability of the reconstituted
(admixed) substance is subject to a shorter shelf life.

European patent publication no. 344,849 and 217,425
disclose containers suitable for separate storage of

ingredients of a medical product in one container.

European patent publication no. 217,425 discloses a device in which the neck of the container has a thread upon which a cap, which is provided with a seal, is retained. Likewise, there is a cup pressed onto the opening in the container neck, inside of which a tubular sleeve is housed which is terminated at its top edge by a discoidal wing according to a truncated-cone shaped portion to carry out the functions of a medicine dropper.

In this container type, after removing the seal from the cap, the cap can be screwed down, the movement of which then pushes the tubular sleeve down, which itself then presses against the bottom of the cup, thereby tearing the cup seal and effecting mixing of the ingredients priorly kept separate in the cup and the container.

Such double chamber container has the inconvenience that after removing the seal from the cap, in order to effect the breaking of the bottom cup, it is necessary to exert a certain effort; at the same time, in order to permit the administration of the mixed product to a patient, it is necessary to press the container; this can lead to an inadvertent separation of the cup and/or the tubular sleeve from the container neck, thus discharging all of the product from the container at once, which is a serious inconvenience. Furthermore, the container as such has no seal, thus preventing its use for separately storing and subsequently mixing two liquid ingredients. Also, the invulnerability of the container is not foreseen, nor a mechanism that permits the dose to be repeated; that is, the container has no suitable dispensing means.

European patent publication no. 344,849 discloses a container device of the above mentioned type in which the

cup has a fastening collar which includes inside an annular rib whereby the cup can be retained on an edge flange of the neck of the container in such a way that it is prevented from being removed when mixing and subsequently administering the mixed product. On the other hand, this is not necessary since this type of container does not act as a medicine dropper and the administration of the mixed product tends to be carried out entirely during treatment. With this container type, breaking off the bottom of the cup is done by pressing the cap down and not screwing it onto the neck as in the prior case, which may mean a difficulty for breaking the bottom of the cup given that the force to be exerted compared to a threading action is much greater.

Besides, the cylindric sleeve may be inadvertently removed during administration of the product, which would likewise be an inconvenience.

Accordingly, the present invention seeks to provide an improved container for separate storage of two ingredients which are to be mixed therein and which can be subsequently dispensed therefrom when needed.

The present invention provides in one form thereof a pharmaceutical product container for separately holding two substances with mixing and dosed dispensation means comprising:

- a first container in which a first one of two substances is receivable, the first container having a retaining flange extending around an opening leading into the inside of the container;

- a second container in which the second one of the two substances is receivable, the second container having a projecting portion terminating in a tearable closure bottom, the projecting portion being receivable in the opening of the first container, a fastening collar

surrounding the projecting portion and being provided with an inward retention rib adapted to engage behind the retaining flange of the first container when the projecting portion is received in the first container in an assembled state, and a neck portion with an opening leading into the interior of the second container and having an exterior thread and a perimeter toothed security flange;

5
10
15
20
- a cap member having an annular safety seal member severably connected to a main cap portion, the main cap portion being provided with an internal thread to allow screwing of the cap member onto the neck portion of the second container, the safety seal member being provided with annularly arranged teeth that are shaped in such a manner that the cap member can be screwed onto the second container a first time permitting the tooth to engage with a toothed security flange of the second container and upon unscrewing prevent rotation of the safety seal member thus separating it from the main cap portion to allow removal thereof; and

25
30
35
- a tubular sleeve member adapted to be received through the opening in the neck portion within the second container in a displaceable manner, the tubular sleeve member having a first terminal portion with a bevelled edge or a pointed longitudinal appendix with decreasing cross-section, the bevelled edge or appendix being adapted to partially tear the closure bottom of the second container upon being axially displaced towards the bottom and pressed against it by the cap member once the safety seal has been removed, and a second terminal portion having an abutment flange from which protrudes a truncated cone-shaped head portion having a dispensing orifice, the abutment flange resting on the neck portion of the second container after tearing of the bottom has been effected, the head portion acting as a drop dispenser for the mixed substances.

Preferably, the tearable closure bottom of the second container has a weakened tearable perimeter in the area where it is connected to the projecting portion of the second container so as to facilitate piercing thereof by the piercing section of the tubular sleeve member. The piercing section is preferably formed in such a manner as to only perform a partial cutting of the weakened perimeter of the severable closure bottom of the second container so that while a big enough opening is created between the interior of both containers, the partly cut off closure bottom is prevented from falling into the first container and remains attached to the second container.

Advantageously, there are provided retaining means on the tubular sleeve member and/or the second container such that once the tearable closure bottom of the second container has been pierced, causing the mixing of the two substances within the connecting containers, a removal of the tubular sleeve member is inhibited when the first container is pressed together so as to dispense the substance mixture through the dispensing head of the tubular member. The retaining means are also to ensure that the tubular sleeve remains within the second container when an internal pressure is exerted, due to improper handling of the first container, which would otherwise tend to remove the sleeve member from the second container.

A further advantageous development of the container includes the provision of adequate seal means between the first and the second container, the second container and the tubular sleeve member, and the orifice in the dispensing head of the sleeve member and the closure cap of the second container. Such a group of sealing means, in example rings can ensure the proper sealing of the container components with respect to one another so as to prevent the substances contained therein to intermix

prematurely or leak from the respective containers.

5 The sealing means (rings) also ensure that after removal of the closure bottom of the second container is effected, leakage of the mixed substances from the container is prevent; the discharge of the substance mixture can only be effected through the dosing medicine dropper formed in the dispensing head portion of the tubular sleeve member.

10 One of the advantages of the above described container assembly is that it permits filling the respective containers in different orders without necessarily having to fill the first container first and the second container secondly in order to prevent cross contamination of the substances contained in the
15 respective containers prior to assembly of the container components.

20 In a specific embodiment of the above described container, the first container can be provided in the form of a bottle with a neck portion terminating in a flanged head serving as the retaining means for the second container; the second container can have a generally cylindrical form with a collar portion having an internal rib adapted to engage behind the retaining flange on the bottle container. The collar can extend
25 downward and terminate at about the same level as the cylindrical projecting portion which is inserted into the opening in the neck of the bottle container such as to cover the neck portion entirely. The tubular sleeve member and the interior of the cylindrical chamber of the
30 top container are co-designed such as to ensure that after tearing of the closure bottom of the second container is effected the tubular sleeve member remains retained in the top container in such a way that it is prevented from inadvertently being removed therefrom when
35 the mixed medical product is dispensed through the

dropper on the dispensing head portion of the sleeve member.

The above mentioned sealing means are preferably provided by labyrinth-type seals and adequate embossments to ensure good sealing of the diverse component of the assembled container with respect to one another before and after piercing of the closure bottom of the second container has been effected.

The piercing portion of the sleeve member and the joining portion of the severable closure bottom are preferably designed in such a manner that once the piercing action is performed, the closure bottom still remains partly joined with the top container by a fine segment so that mixing of the two substances contained in the containers is not hampered and at the same time it is prevented from falling into the bottle container.

The pierceable closure bottom of the top (second) container can have a weakening along its perimeter either on the inner surface or the outer surface of the wall, or in both, for the purpose of providing a better piercability and thus preventing particle formation due to poor cutting performance. The provision of a thickened centre area in the severable closure bottom of the second container ensures against migration which may exist, since migration depends on the contact surface and on the thickness of the bottom.

The specific design of the components forming the pharmaceutical product container allow, after removal of the security seal from the cap member, that the cap can be screwed down on the second container thereby effecting displacement of the tubular sleeve received in the second container so as to break the closure bottom of the top container without exerting additional effort and establishing a mutual retention of the sleeve member

within the second container.

The invention will be more fully understood and advantages thereof will become more readily apparent from the ensuing description of preferred embodiments of the invention illustrated by way of example only in the
5 accompanying drawings in which:

Figure 1 shows a partially sectioned and exploded view of the components that make up a container for separate storage of two ingredients and mixing and
10 dispensing thereof according to a first embodiment of the invention;

Figure 2 is a partially sectioned view of the fully assembled components of the container of Figure 1 and in which the security seal has already been broken;

15 Figure 3 shows an exploded view of the components that make up a container according to a second embodiment of the invention;

Figure 4 shows a view equivalent to that of Figure 3, with the exception that the components are sectioned;

20 Figure 5 shows a section view of the second embodiment according to Figure 3 in which the components are assembled and ready for use, but without the bottom of the top container having been broken;

25 Figure 6 is a side view of Figure 5 without sectioning of the components;

Figure 7 is section view equivalent to that of Figure 5, with the exception that after having removed the seal, the bottom of the container has been broken upon screwing down the cap, the cap not being
30 illustrated;

Figure 8 is a view similar to Figure 7 but without sectioning of the components and showing the cap; and

Figure 9 is a sectioned view of the top container in an enlarged view.

5 Referring first to Figures 1 and 2, a first embodiment of a "double-container" dispensing bottle according to the invention is described. The double-container comprises a bottom container 1 in which one ingredient 4 (for example a fluid) to be separately
10 stored and subsequently mixed with another substance prior to the administration of the mixture can be received. The bottom container 1 has a neck portion 2 with an upper edge in the form of a rim flange 3 surrounding the container opening in the container neck
15 2.

A top container 5 is mounted on the neck portion 2 of the bottom container 1 and is provided with an annular downwardly open collar 11 which has an interior annular rib 12 by means of which the top container 5 can be
20 securely fixed onto the bottom container 1; in an assembled state, the annular rib 12 engages behind the rim flange 3.

The top container 5 has a cylindrical tubular member projecting downwardly from the collar 11 which terminates
25 in a tearable bottom closure 6. The tearable bottom 6 ensures that a second granular substance 7 received within the cavity of the top container 5 is held separate from the first substance contained in the bottom container 1.

30 The top container 5 further comprises an upper tubular neck section 8, the outside of which is provided with a helicoidal thread 9 to permit screwing on/off a cap 18 onto the upper container 5. The upper container 5

is further provided in the neck portion 8 above the collar 11 with a perimeter flange 10 which constitutes a retaining means for a seal 19 provided on the lower part of the cap 18.

5 A tubular sleeve member 13 has a lower bevel-edged piercing portion 17 with decreasing cross-section; the bottom member 13 is adapted to be received through the upper opening of the top container 5 within the chamber that houses the second substance 7.

10 The upper part of the tubular sleeve 13 is provided with a discoidal flange 14 from which extends upwardly a truncated-cone shaped portion 15 with an orifice 16 in its terminal end; this design of the tubular sleeve allows it to act as a medicine dropper.

15 The perimeter flange 10 of the upper container 5 has a plurality of saw-teeth, which are complemented by another plurality of saw-teeth provided in the interior rim of the seal portion 19 of the cap 18.

20 In this way it is possible to screw the cap 18 onto the upper container 5 until the seal 19 of the cap 18 contacts with the upper surface of the collar 11 as illustrated in Figure 2. In this position the locking of the seal 19 with the perimeter flange 10 is produced by the interaction of the respective plurality of saw-teeth,
25 whereby upon screwing-off the cap 18 the ring seal 19 which is connected by a thin film to the cap 18 can be separated, making it possible to remove the seal ring.

30 Once the seal ring has been removed, and upon screwing on again the cap 18 onto the neck portion of the upper container 5 the cap 18 comes to rest with its lower rim on the perimeter flange 10; during this process, the tubular sleeve 13 is moved axially downwards by the cap 18, thus causing partial cutting of the bottom closure

portion 6 by means of the bevel edge 17 and tearing open the top container 5 towards the bottom container and allowing mixing of the substances 4, 7 respectively contained therein.

5 The screwing down action of the cap 18 whereby the tubular sleeve 13 is pushed down tearing open the bottom closure wall 6 and inserted through the opening thus created in the bottom closure subsequently of the second container 5 can be done without any additional effort
10 when compared to a normal screwing action.

 Once the mixing of the substances 7 and 4 in the lower container 1 has been carried out, it is possible to administer the mixed substance in a dosed manner upon pressing on the bottom container 1, the tubular sleeve 13
15 being held in the orifice formerly closed by the bottom closure wall 6 in the upper container 5.

 While this embodiment may have some problems regarding sealing engagement of some of its component elements, it is nonetheless a satisfactory container for
20 medical substances which require separate storage from one another prior to their mixing and administration to a patient.

 A second embodiment of the invention is described with reference to Figures 4 to 9. This embodiment
25 addresses the above mentioned sealing and retaining problems between the different components of the "double container" bottle.

 While the bottom container 1 is similar to the one described with reference to the first embodiment but for
30 the differences noted below, the top container 5', the tubular sleeve 13 and the cap 18' are modified.

 The top container 5' is provided along the entire

length of its internal chamber with a number of transversely placed sealing rings 21 as illustrated in Figure 4; these sealing rings 21 interact or work together with a sealing ring 25 provided close to the bottom edge on the outside circumference of the tubular sleeve 13 in such a way that upon introducing the tubular sleeve 13 into the inside chamber of the top container 5', a sealing engagement between these two components is ensured.

10 Besides this modification, in order to facilitate tearing of the bottom wall 6 in the lower tubular section of the top container 5', the bottom edge of the tubular sleeve 13 has a pointed, in cross-section decreasing longitudinal appendix 24 and a hereto diametrically
15 oppositely arranged longitudinal recess 27 which ensure that cutting of the perimeter of the bottom (6) is not complete, thus preventing complete detachment of the bottom 6 from the lower tubular portion of the top container 5'.

20 The discoidal flange 14 on the upper part of the tubular sleeve 13 is provided with a peripheral edge with a certain conicity defining a bevel 26 which is intended to work together with a complementarily formed annular recess 22 in the opening of the neck portion 8 of the top
25 container 5' in such a way that upon screwing down of the cap 18', after the seal ring 19 of the cap 18' has been removed, (as has been described above with reference to the first embodiment), the bevel 26 remains axially fixed in the annular recess 22 in the opening of the neck
30 portion 8 of the top container 5' in such a manner that the top container 5' and the sleeve member 13 are connected to one another in an effective manner and it is avoided that the sleeve member 13 can easily be removed from the top container 5'.

35 The top part of the neck 2 of the bottom container 1

is provided with a sealing ring 23 which permits a sealing engagement between the top container 5' and the bottom container 1, once the annular rib 12 in the collar portion 20 remains hooked behind the flange edge 3 surrounding the neck opening of the bottom container 1, when the top and bottom container have been assembled.

The truncated-cone shape upper terminal portion 15 of the tubular sleeve 13 operates as a medicine dropper with controlled dosage by means of a cylindrical dispensing portion 29 extending into the inside cavity of the sleeve. Furthermore, the dispensing orifice of the tubular sleeve 13 is provided with a recess 28 that works together with a pin projection in the interior of the cap 18' (not shown) to guarantee sealing engagement of the cap 18' with the tubular sleeve 13.

Therefore, this embodiment provides for three levels of sealing and prevention mechanisms against improper use. The first level is established between the bottom container 1 and the top container 5', the second between the tubular sleeve 13 and the top container 5', and the third between the cap 18' and the tubular sleeve 13 by means of the above described elements.

The tearable bottom wall or closure 6 in the lower cylindrical projecting portion of the top container 5' is very thick in its centre part so as to reduce migration through said bottom 6, and has a perimeter weakened thickness on the inner side 30 or on the outside 31 so as to ensure proper partial tearing-off of the closure bottom 6 at its perimeter edge and prevent inadequate tearing as well as production of loose particles upon tearing the bottom open (see Figure 9).

The operating mechanism of the second embodiment is very similar to that described with reference to the first embodiment.

Besides, it should be appreciated that in the second embodiment, the collar portion 20 is lengthened towards the bottom of the top container 5' so that it can completely surround the neck portion 2 of the bottom container 1 and form an extension with similar outer diameter than the main portion of the bottom container 1 so that in an assembled state a continuous outer container surface is presented.

Both of the above described embodiments permit the filling of the bottom container 1 with a first substance 7 whereupon it can be effectively sealed by assembling the top container 5 or 5' onto the first container; the top container can then be filled with a second substance 4 and the top container 5, 5' can be closed by the tubular sleeve 13 received through the top opening in the neck portion of the upper container; the dispensing orifice of the sleeve member 13 can itself be closed by screwing-on the cap 18, 18' onto the top container 5, 5'.

On the other hand, it is also possible to first fill the top container 5, 5' with substance 7, then close the top container by inserting the tubular sleeve 13 thereinto and screwing on the cap 18, 18'; the bottom container 1, which has been previously filled with a substance 4 can subsequently be attached to the top container 5 and 5', thereby sealing-off the entire bottle. Another way of assembling the different components of the "double container" consists of filling the top container 5, 5', closing it with the tubular sleeve 13, or filling the interior of the tubular sleeve 13 onto which the cap 18, 18' has been previously embossed and then subsequently sealing the top container 5, 5'.

The described containers provide versatility in filling the container chambers with fluids of different viscosities, solids, (which may be in powder or granular

form), lyophilised substances or pills, and which have to be packaged separately prior to their mixing and subsequent administration in order to increase shelf life of the medical product which otherwise would be given if the separate substances were to be admixed and stored in a single chamber container.

5

THE CLAIMS DEFINING THE INVENTION ARE AS FOLLOWS:

1. A pharmaceutical product container for separately holding two substances with mixing and dosed dispensation means comprising:

5 - a first container in which a first one of two substances is receivable, the first container having a retaining flange extending around an opening leading into the inside of the container;

10 - a second container in which the second one of the two substances is receivable, the second container having a projecting portion terminating in a tearable closure bottom, the projecting portion being receivable in the opening of the first container, a fastening collar surrounding the projecting portion and being provided with an inward retention rib adapted to engage behind the retaining flange of the first container when the projecting portion is received in the first container in an assembled state, and a neck portion with an opening leading into the interior of the second container and having an exterior thread and a perimeter toothed security flange;

25 - a cap member having an annular safety seal member severably connected to a main cap portion, the main cap portion being provided with an internal thread to allow screwing of the cap member onto the neck portion of the second container, the safety seal member being provided with perimaterally arranged teeth that are shaped in such a manner that the cap member can be screwed onto the second container a first time permitting the tooth to engage with a toothed security flange of the second container and upon unscrewing prevent rotation of the safety seal member thus separating it from the main cap portion to allow removal thereof; and

35 - a tubular sleeve member adapted to be received through the opening in the neck portion within the second

container in a displaceable manner, the tubular sleeve member having a first terminal portion with a bevelled edge or a pointed longitudinal appendix with decreasing cross-section, the bevelled edge or appendix being adapted to partially tear the closure bottom of the second container upon being axially displaced towards the bottom and pressed against it by the cap member once the safety seal has been removed, and a second terminal portion having an abutment flange from which protrudes a truncated cone-shaped head portion having a dispensing orifice, the abutment flange resting on the neck portion of the second container after tearing of the bottom has been effected, the head portion acting as a drop dispenser for the mixed substances.

2. A pharmaceutical product container according to claim 1, wherein the first terminal portion of the tubular sleeve member has a longitudinal recess adapted to prevent complete separation of the closure bottom of the second container from the projecting portion such that the bottom portion remains partly connected with the projecting portion but intercommunication between the interiors of the first and second containers is ensured.

3. A pharmaceutical production container according to claim 1 or 2, wherein the abutment flange is disc shaped and provided with a peripheral edge having a predetermined conicity such as to define a bevel with regards to an annular recess provided in the opening of the second container, the bevelled abutment flange and the annular recesses being adapted such as to retain the tubular sleeve securely within the second container in an axially non displaceable manner once tearing of the closure bottom is effected.

4. A pharmaceutical product container according to any one of the preceding claims, wherein the first container is provided with a sealing ring in the opening

leading to the interior of the first container, the sealing ring being adapted to engage with the outside surface of the projecting portion of the second container being received in the opening of the first container.

5 5. A pharmaceutical product container according to any one of the preceding claims, wherein the tubular sleeve member has close to its first terminal portion at least one peripheral sealing ring on its outer surface adapted to abut against the form-corresponding interior
10 wall of the second container to provide airtight sealing between the tubular sleeve member and the second container.

15 6. A pharmaceutical product container according to any one of the preceding claims, wherein the second container has a cylindrical interior chamber, the chamber wall being provided with at least one sealing ring adapted to abut against the outer surface of the tubular sleeve member received in said second container in an airtight manner.

20 7. A pharmaceutical product container according to any one of the preceding claims, wherein the truncated cone-shaped head portion of the tubular sleeve member has a recess surrounding the dispensing orifice, and wherein the main cap portion of the cap member is provided with a
25 projecting pin adapted to be received within said recess in sealing engagement.

30 8. A pharmaceutical product container according to any one of the preceding claims, wherein the tearable closure bottom of the second container is provided with a thickness reduced area in the region where it is connected to the side walls of the projecting portion in order to facilitate piercing by the tubular sleeve members bevelled edge or appendix.

9. A pharmaceutical product container according to claim 8, wherein the tearable closure bottom of the second container has a thickened centre portion so as to prevent piercing thereof by the terminal piercing portion
5 of the tubular sleeve member.

10. A pharmaceutical product container according to claim 8 or 9, wherein the tearable closure bottom of the second container is provided with a weakened thickness on the inner or the outer surface at the perimeter where the
10 tearable closure bottom is connected with the projecting portion such as to allow tearing open the closure bottom at its perimeter without producing particles.

11. A pharmaceutical product container according to any one of the preceding claims, wherein the truncated
15 cone-shaped head portion of the tubular sleeve member has on its inside a cylindrical protrusion extending towards the first terminal piercing portion of the sleeve member, the cylindrical protrusion having a channel therethrough ending in the orifice and being adapted to perform as a
20 medicine dropper.

12. A pharmaceutical product container substantially as herein described with reference to Figures 1-2 and Figures 3-9, respectively.

Dated this 10th day of May 1995

25 LABORATORIOS CUSI S A
By their Patent Attorney
GRIFFITH HACK & CO

1

ABSTRACT

Pharmaceutical product container with two separate sub-
stances and a mixing device and dosed dispensation

Of the type that permit the mixing of two products lo-
5 cated in two containers (1 and 5, 5'.) In the inside of the
top container (5, 5'), there is a tubular sleeve (13) with
a wing terminated by a truncated-cone shaped portion (15)
like a medicine dropper, and with a bevel-edged bottom edge
(17) to cut the bottom of the vessel (5), upon screwing down
10 the cap (18) after removing a safety seal (19.) The con-
tainer (5, 5') extends into a neck (8.) It is characterized
in that the mouth of the neck (8) has an annular recess (22)
and a discoidal wing (14) provided with a bevel (26) that
is retained in the annular recess (22) upon the bottom of
15 the container (5) breaking, preventing the removal of the
tubular sleeve (13), the latter containing a pointed longi-
tudinal appendix (24) to break the tearable bottom (6) with-
out making any additional effort. Diametrically opposite the
appendix (24) there is a longitudinal recess (27) that pre-
20 vents the complete cutting of the perimeter of the bottom
(6) which remains connected to the top container (5) by a
small piece, preventing the falling of the bottom (7) to
the bottom container (1.)

It has diverse seals and sealing rings. Its assembly is
25 adaptable to the packaging process and conditioning chosen,
permitting the selective and independent filling of the top
part and bottom part as if there were two separate containers.

30

35

41662/93

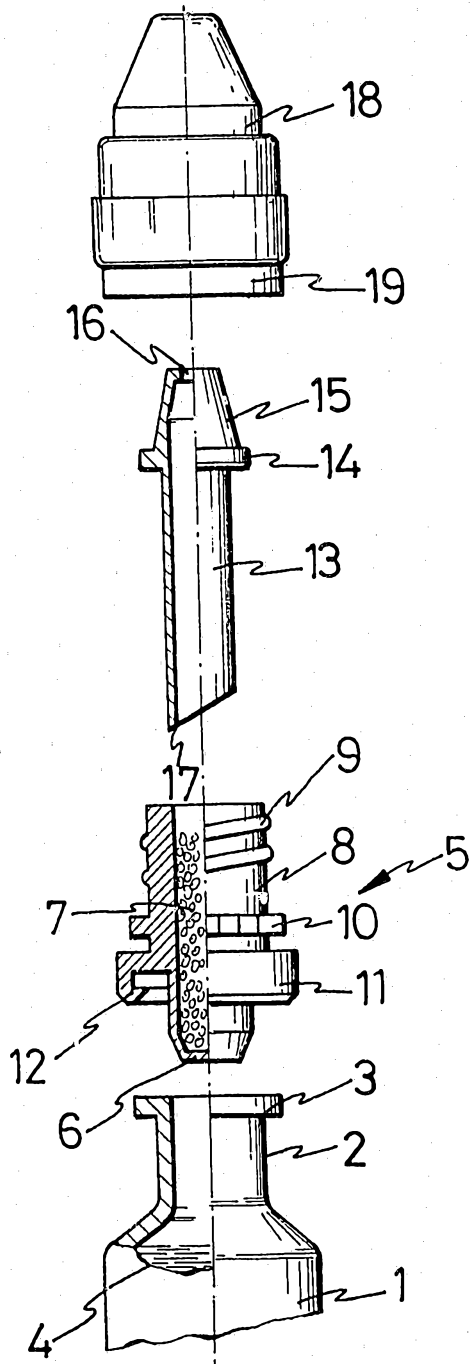

FIG. 1

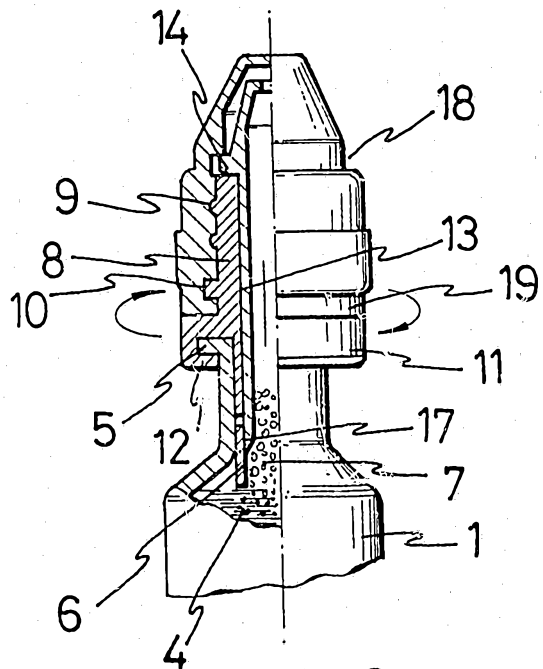

FIG. 2

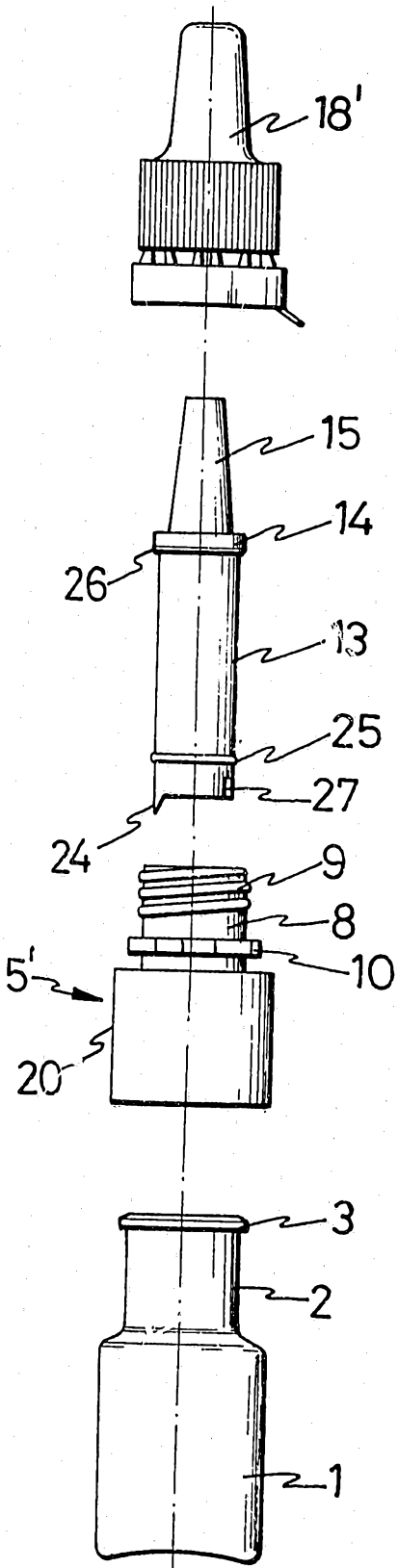

FIG. 3

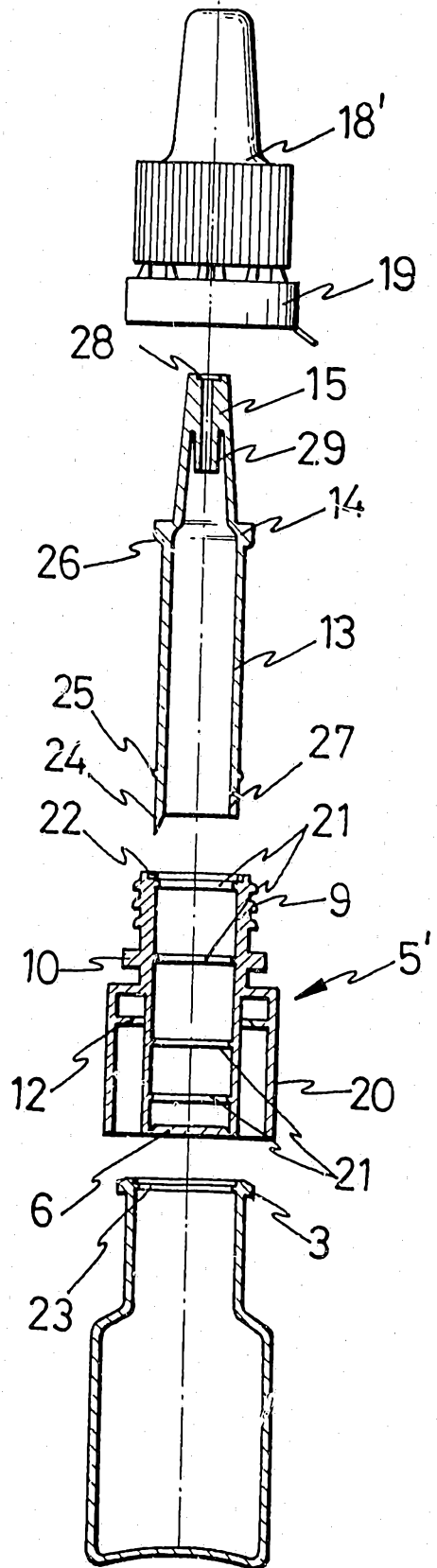

FIG. 4

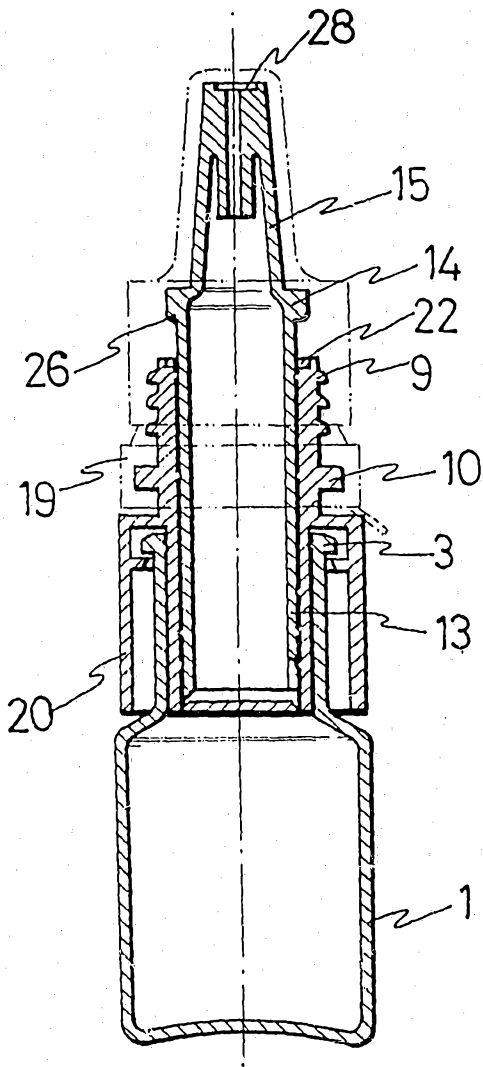

FIG. 5

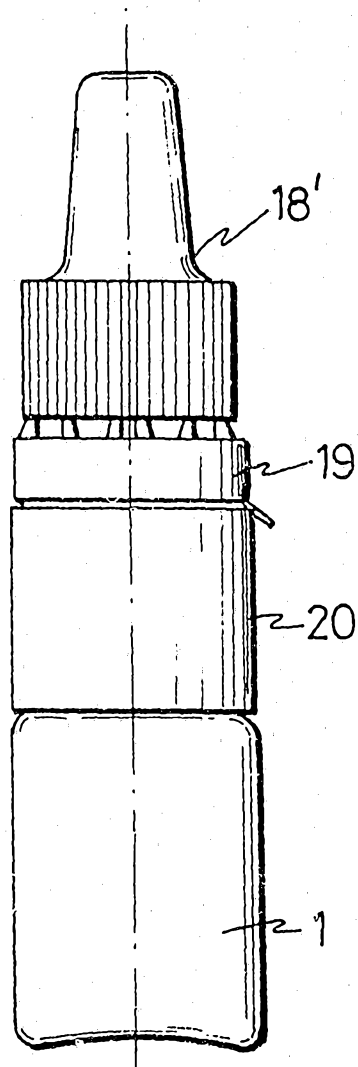

FIG. 6

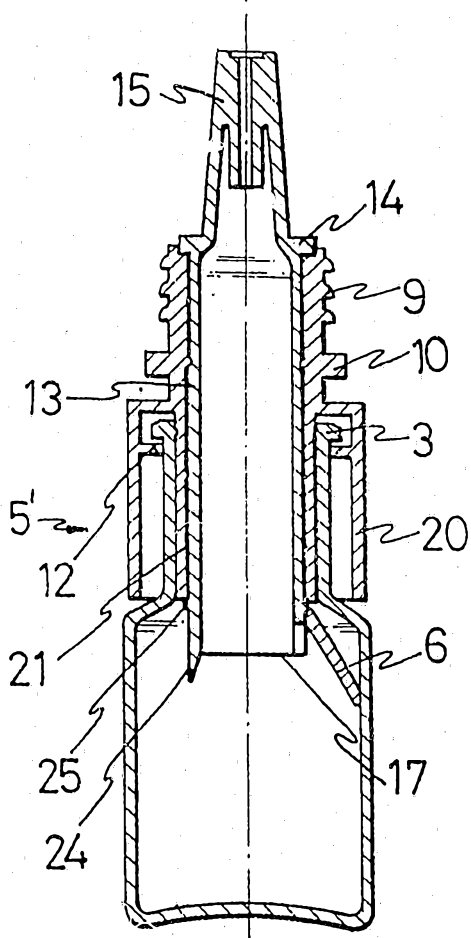

FIG. 7

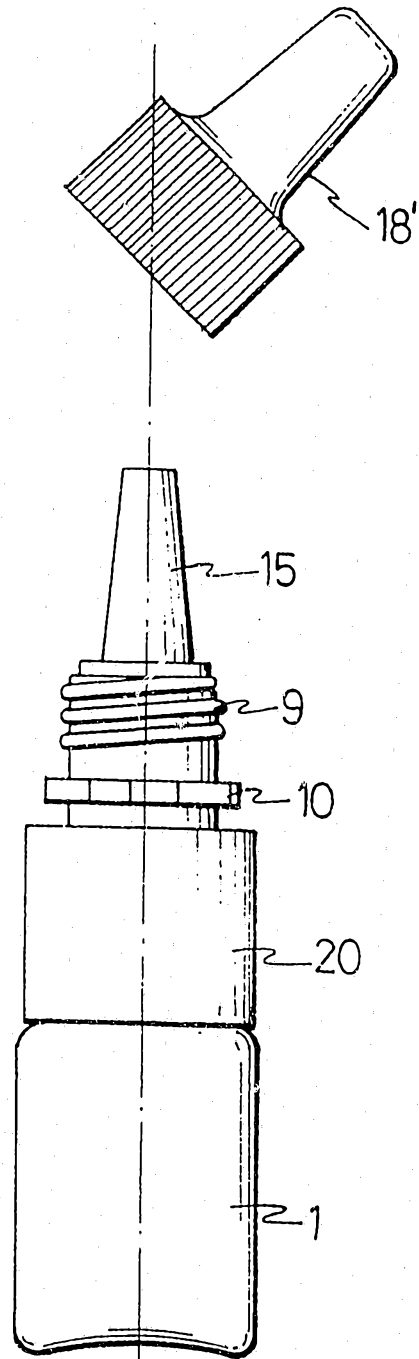

FIG. 8

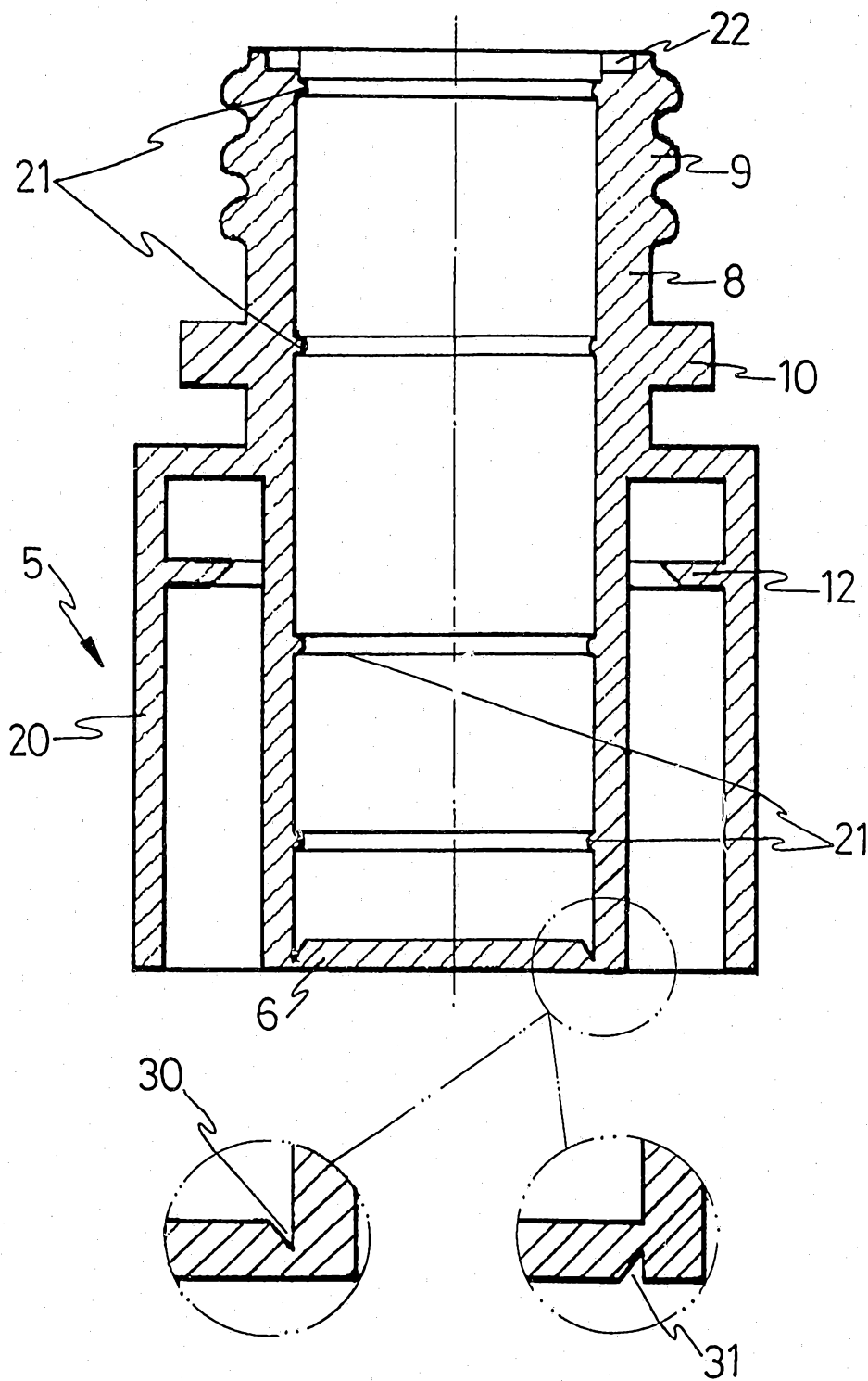

FIG. 9