

(19) World Intellectual Property Organization
International Bureau



(43) International Publication Date
20 September 2001 (20.09.2001)

PCT

(10) International Publication Number
WO 01/69903 A1

(51) International Patent Classification⁷: H04M 3/42,
H04Q 7/22

Oulu (FI). KEINÄNEN, Kimmo [FI/FI]; Talvikkitie 18
A 3, FIN-90580 Oulu (FI). HUOSTILA, Tero [FI/FI];
Pursimiehenkatu 25 A 7, FIN-00150 Helsinki (FI).

(21) International Application Number: PCT/FI01/00243

(74) Agent: KOLSTER OY AB; Iso Roobertinkatu 23, P.O.
Box 148, FIN-00121 Helsinki (FI).

(22) International Filing Date: 13 March 2001 (13.03.2001)

(25) Filing Language: English

(81) Designated States (national): AE, AG, AL, AM, AT, AT
(utility model), AU, AZ, BA, BB, BG, BR, BY, BZ, CA,
CH, CN, CO, CR, CU, CZ, CZ (utility model), DE, DE
(utility model), DK, DK (utility model), DM, DZ, EE, EE
(utility model), ES, FI, FI (utility model), GB, GD, GE, GH,
GM, HR, HU, ID, IL, IN, IS, JP, KE, KG, KP, KR, KZ, LC,
LK, LR, LS, LT, LU, LV, MA, MD, MG, MK, MN, MW,
MX, MZ, NO, NZ, PL, PT, RO, RU, SD, SE, SG, SI, SK,
SK (utility model), SL, TJ, TM, TR, TT, TZ, UA, UG, US,
UZ, VN, YU, ZA, ZW.

(26) Publication Language: English

(30) Priority Data:
20000589 14 March 2000 (14.03.2000) FI
20001249 24 May 2000 (24.05.2000) FI

(71) Applicant (for all designated States except US): SONERA
OYJ [FI/FI]; Teollisuuskatu 15, FIN-00510 Helsinki (FI).

(84) Designated States (regional): ARIPO patent (GH, GM,
KE, LS, MW, MZ, SD, SL, SZ, TZ, UG, ZW), Eurasian
patent (AM, AZ, BY, KG, KZ, MD, RU, TJ, TM), European
patent (AT, BE, CH, CY, DE, DK, ES, FI, FR, GB, GR, IE,
IT, LU, MC, NL, PT, SE, TR), OAPI patent (BF, BJ, CF,
CG, CI, CM, GA, GN, GW, ML, MR, NE, SN, TD, TG).

(72) Inventors; and
(75) Inventors/Applicants (for US only): IMMONEN,
Marko [FI/FI]; Purjehtijantie 6 A 6, FIN-90560 Oulu (FI).
JUNTUNEN, Ari [FI/FI]; Sihtikuja 1 D 51, FIN-90520

[Continued on next page]

(54) Title: BILLING IN MOBILE COMMUNICATIONS SYSTEM EMPLOYING WIRELESS APPLICATION PROTOCOL

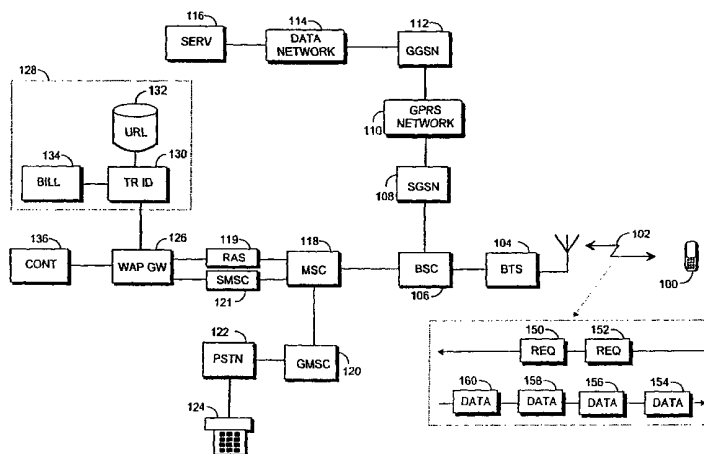

(57) Abstract: The invention relates to a network part of a mobile communications system employing a wireless application protocol and a method for generating billing data in a mobile communications system employing a wireless application protocol. The network part of the mobile communications system comprises: means (104, 106, 118) for setting up a bi-directional wireless data transmission connection (102) to a subscriber terminal (100) of the mobile communications system; means (126) for transmitting a service request (150, 152) sent by the subscriber terminal (100) to a contents server (136) providing the service; means (126) for transmitting response data (154, 156, 158, 160) generated in the contents server (136) on the basis of the service request (150, 152) to the subscriber terminal (100). The network part further comprises: identifying means (130, 132) for identifying transactions associated with the service from among the service requests (150, 152) and the response data (154, 156, 158, 160) on the basis of the identification of the Internet address of the service referred to in the service request (150, 152) and the response data (154, 156, 158, 160); and billing means (134) for generating billing data for the service using the transactions identified on the basis of the service's Internet address.



WO 01/69903 A1



Published:

— with international search report

For two-letter codes and other abbreviations, refer to the "Guidance Notes on Codes and Abbreviations" appearing at the beginning of each regular issue of the PCT Gazette.

BILLING IN MOBILE COMMUNICATIONS SYSTEM EMPLOYING WIRELESS APPLICATION PROTOCOL

FIELD OF THE INVENTION

[0001] The invention relates to the generating of billing data in a mobile communications system employing a Wireless Application Protocol (WAP).
5

PRIOR ART

[0002] The WAP is a protocol definition which allows subscriber terminals of a mobile communications system to use services implemented on the Internet or in a corporate intranet. Further information about WAP is available in the home pages of the WAP Forum, which defines the WAP specifications, at <http://www.wapforum.org>.
10

[0003] In WAP the Hypertext Markup Language HTML typically used in WWW services (World Wide Web) to describe the contents structure and outer appearance of hypertext is replaced by WML (Wireless Markup Language).
15

[0004] WAP services do not employ similar search keys, such as "share" (of the stock market), as those to which users are accustomed in the value added short message services of the GSM (Global System for Mobile Communications) environment. The network part of a mobile communications system employing the WAP typically comprises a WAP Gateway which is used to identify a service request coming from a subscriber terminal and to transfer the request to the Contents Server that provides the service requested. The WAP Gateway then transmits the response data generated by the contents server on the basis of the service request to the subscriber terminal.
20
25

[0005] Since WAP services are not based on a unique search key, but a service is requested using its Internet address (Uniform Resource Locator, URL), the generating of billing data for the service is problematic. In principle, billing may be based on three different elements, depending on how the system is implemented.
30

[0006] If the bi-directional data transmission connection between the subscriber terminal and the mobile communications system is implemented using circuit-switched data transfer, such as a data call, then it is natural to apply connection time charging in the billing. However, a problem in this is that the billed amount is difficult to divide among the different services
35

used. In addition, this does not allow an individual service to be charged for on the basis of its contents.

[0007] The data transmission can also be executed on a packet-switched connection, using the short message service or GPRS (General Packet Radio Service), for example, in which case billing can naturally be carried out on the basis of the number of packets transferred.

[0008] However, there are many services for which, due to their nature, transaction-based billing is the most reasonable both for the user of the service and its provider. Transaction in this context means a single service event. For example, if the service concerned is the current stock exchange quotation of a share, it is subject to a fixed, service transaction-based price not dependent on the connection time or the number of packets transferred.

[0009] In a mobile communications system which employs a wireless application protocol and packet-switched data transfer, for example, and in which a service is identified on the basis of its Internet address, transaction-based billing is difficult to implement because Internet addresses are complex in their structure and therefore the monitoring of traffic in the WAP gateway and in the associated billing system is problematic.

CHARACTERISTICS OF THE INVENTION

[0010] It is an object of the invention to provide an improved network part for a mobile communications system employing a wireless application protocol and an improved method for generating billing data in a mobile communications system employing a wireless application protocol. According to an aspect of the invention there is provided a mobile communications network part as disclosed in claim 1. According to another aspect of the invention there is provided a method for generating billing data as disclosed in claim 10. Other preferred embodiments of the invention are disclosed in the dependent claims.

[0011] The underlying idea of the invention is to create a general-purpose method for identifying a service by analysing its Internet address, the method thus allowing also events associated with a single transaction to be identified for the purpose of generating billing data.

[0012] The invention describes a general method for implementing transaction-based billing in a mobile communications system employing a wireless application protocol, the method reducing significantly the need for

case-specific solutions. Since the solution is reproducible, it can be used in connection with a variety of services.

DESCRIPTION OF THE DRAWINGS

[0013] In the following, the preferred embodiments of the invention will be described, by way of example, with reference to the accompanying drawings, in which

Figure 1 is a schematic block diagram of a network part of a mobile communications system employing a wireless application protocol;

Figure 2 illustrates the structure of a service identification table, together with examples of how Internet addresses are identified;

Figure 3 is a signal sequence diagram illustrating messages transmitted in the mobile communications system employing the wireless application protocol;

Figure 4 is a flow diagram illustrating a method for generating billing data in the mobile communications system employing the wireless application protocol.

DESCRIPTION OF THE EMBODIMENTS

[0014] Figure 1 is a schematic view of the structure of a network part of a mobile communications system. The mobile communications system may be for example a GSM system, GPRS system, or some other mobile system employing a wireless application protocol. Figure 1 only shows the blocks that are essential for disclosing the invention, although it is apparent to a person skilled in the art that a conventional mobile communications system also comprises other functions and structures which need not be described in greater detail here. In this context, the mobile communications system network part refers to a fixed network infrastructure, such as base stations 104, base station controllers 106, mobile services switching centres 118, packet transfer systems 108, 110, 112, and other similar entities. Consequently, subscriber terminals 100 and systems, such as the global public switched telephone network 122, connected to the mobile communications system over predetermined interfaces are left outside the network part.

[0015] As shown in Figure 1, a circuit-switched connection may be set up from the subscriber terminal 100 to a telephone 124, or other terminal, connected to the public switched telephone network 122. The subscriber

terminal 100 may be for example a fixedly mounted, vehicle mounted or portable terminal.

[0016] The base station system, i.e. the radio network subsystem, comprises base stations 104 and base station controllers 106 controlling the
5 base stations 104. In some environments the base station controller 106 may be referred to as a radio network controller, and the base stations 104 as nodes B.

[0017] A base station 104 comprises transceivers which are used for creating the actual radio links 103 to the subscriber terminals 100. A base
10 station 104 may also comprise antenna units. In some environments, the antenna units may be used for implementing radio links that employ directional antenna beams.

[0018] The base station controller 106 comprises a switching field which is used for switching speech and data and for connecting signalling
15 circuits. The base station system further comprises a transcoder. The transcoder 108 transforms different digital speech coding formats used between the public switched telephone network and the radio telephone network to make them mutually compatible, for example from the fixed network format of 64 kbit/s to a cellular radio network format (of 13 kbit/s, for example),
20 and vice versa. The division of functions between the base station controller 106 and the base station 104 as well as their physical structure may vary depending on the implementation. The base station 104 is typically responsible for implementing the radio path as described above. The base station controller 104 typically carries out radio resources management,
25 control of inter-cell handover, power adjustment, timing and synchronization, paging of a subscriber terminal.

[0019] The network part further comprises a mobile services switching centre 118 and a gateway mobile services switching centre 120 which is responsible for the external connections of the mobile
30 communications system, in this case for those to the public switched telephone network 122.

[0020] The switching field of the base station controller 106 can be used for switching both to the public switched telephone network 122 and to the packet transfer network 110. The radio system also allows for packet-
35 switched transmission based on the GPRS (General Packet Radio Service),

for example. The GPRS is a service in which air interface transfer capacity free from circuit switching can be used for packet transfer.

5 **[0021]** Packet transfer is carried out over the Internet 114 from a computer 116 connected to the mobile communications system to the subscriber terminal 100.

10 **[0022]** The connection between the packet transfer network 110 and the switching field of the base station controller 106 is set up by a serving GPRS support node 108 SGSN. The support node 108 is responsible for transferring packets between the base station system and a gateway GPRS support node GGSN 112 and to keep record of the location of the subscriber terminal 100 within its area.

15 **[0023]** The gateway node 112 connects the public packet transfer network 114 to the packet transfer network 110. The interface may be provided using an Internet protocol or X.25 protocol. The packet transfer network 110 is typically a private network employing an Internet protocol and carrying signalling and user data. Below the Internet protocol layer, the structure of the network may vary by operator both in architecture and in protocols. The public packet transfer network 114 may be the world-wide Internet, for example.

20 **[0024]** Figure 1 illustrates various possibilities for implementing a data transmission connection for a service employing the WAP. It is to be noted that the description is in no way binding, but illustrative, because the implementation of the WAP in the GPRS system is still under development and therefore the responsibilities and functions of the different parts have not
25 been fixed yet. For this reason, instead of describing in greater detail a WAP service implemented using the GPRS, we shall describe a WAP service based on a circuit-switched data call or a short message service. The telecommunications connection used for implementing the WAP service may also be referred to as a Bearer Service. A bearer service may be implemented
30 in any manner conforming to the WAP service specifications; in other words, in addition to the short message service and circuit-switched data call already mentioned, for example the CDMA technology (Code Division Multiple Access), the American D-AMPS system (Digital Advanced Mobile Phone Service, the CDPD (Cellular Digital Packet Data) service of the American
35 AMPS system, or the Japanese PDC-P (Personal Digital Cellular Packet) system may be used.

[0025] As shown in Figure 1, the data transmission connection 102 is set up from the subscriber terminal 100 to the base station 104 from which a connection is established through the base station controller 106 and the mobile services switching centre 118 to the WAP Gateway 126. To allow a circuit-switched data call to be connected, there is a RAS (Remote Access Server) 119 between the WAP Gateway 126 and the mobile services switching centre and, correspondingly, a short message centre 121 for connecting a short message service.

[0026] As already stated, the connection from the WAP Gateway 126 to a contents server 136 providing the service is established on the basis of the Internet address of the service, i.e. the WAP Gateway 126 implements means 126 to transmit a service request 150, 152 sent by the subscriber terminal 100 to the contents server 136 providing the service. Similarly, the WAP Gateway 126 implements means 126 to transmit to the subscriber terminal 100 response data 154, 156, 158, 160 generated in the contents server 136 on the basis of the service request 150, 152. The WAP Gateway is preferably implemented using equipment provided with a microprocessor, such as a computer comprising peripheral devices and the necessary system and application software. In other words, said means are preferably computer program modules executing a desired functionality. At the design and implementation of the system, the functions between the software and the hardware are divided for example according to the costs of manufacture costs and the data processing capacity and speed required. Tasks that require high speed can be carried out using ASICs (Application Specific Integrated Circuit).

[0027] Although Figure 1 shows the service requests 150, 152 and the response data 154, 156, 158 160 in the form of packets, such as messages of the short message service, they can equally well be transferred on a circuit-switched connection, such as a data call. What is essential is that the traffic can be analysed to allow transactions associated with a specific service to be identified therein. In the example of Figure 1 there are four response data packets 154, 156, 158 160 corresponding to the user's two service requests 150, 152, but any combinations are possible. In other words, there may be one or more service requests and, similarly, the response data may be divided into one or more parts. This is specifically what causes problems in identifying which traffic belongs to which service.

[0028] The WAP gateway 126 is connected to a billing system 128 which may be a separate system or a part of the WAP gateway 126, depending on the implementation.

[0029] The billing system 128 comprises identifying means 130, 5 132 for identifying transactions associated with the service referred to in the service requests 150, 152 and response data 154, 156, 158, 160 on the basis of the identified Internet address of the service referred to in the service request 150, 152 and the response data 154, 156, 158, 160, and billing means 134 for generating billing data for the service by using the transactions 10 identified on the basis of the service's Internet address. The identifying means 130, 132 and the billing means 134 are implemented similarly as the WAP Gateway 126 in the above described alternatives: the implementation is based on a suitable hardware and software combination. In addition, the billing system 128 comprises either a specific invoice handling part 134 for editing 15 the invoice for transmission to the customer, or an interface 134 to a separate invoice handling part outside the billing system.

[0030] Before discussing Internet address identification, we shall describe the structure of an Internet address. An Internet address (Uniform Resource Locator, URL) may also be referred to as a WWW address, web 20 address or net address. It is a standard defined by the Network Working Group to describe addresses used on the Internet. In principle a text sequence forming an Internet address consists two parts: a schema and a schema-specific part, with a colon in between.

[0031] The schema defines the protocol to be used, for example:
25 http (Hypertext Transfer Protocol)
https (Secure Hypertext Transfer Protocol)
ftp (File Transfer Protocol)
news (Newsgroups)

[0032] The interpretation of the schema-specific part depends on 30 the schema used. The schema-specific part typically defines the IP address (Internet Protocol). At the beginning of the schema-specific part, two slashes are used to show that the address conforms to the common Internet schema syntax.

[0033] There is no need to disclose the standard in its entirety in 35 this context, but a simple example will be sufficient for understanding the idea. Let us take a look at the following Internet service address:

<http://www.sonera.fi/english/mobileportal/flash.html>

This address can be interpreted as follows:

"http" represents the schema used;

"/" indicates that the name in the address conforms to the Internet

5 syntax;

[0034] "www.sonera.fi" is in practice the name of the computer where the service resides. The name in question is a Domain Name which conceals the real name of the computer and which in the Internet protocol version 4 consists of a sequence of four numbers separated by a dot, each
10 number comprising a maximum of three digits, for example 101.111.151.201. Each number is represented by eight bits, which means that its value can vary from 0 to 255. In the Internet protocol version 6, a sequence consists of six numbers. A specific network element, Domain Name Server (DNS), attaches the domain name to a specific address conforming to the Internet protocol;

15 **[0035]** "flash.html" is the name of the page (or service) that will be shown to the user, the character string "/english/mobileportal" preceding it defining the location of the page in the computer.

[0036] In a preferred embodiment the identifying means 130, 132 are formed of two parts, the actual identifying means 130 and a service
20 identification table 132 associated with them. The table may be a software data structure, a file used by the software or, if the table is large, a database set up using some database software.

[0037] Figure 2 illustrates an example of the structure of the service identification table. Each line in the service identification table 132 forms one
25 data record. In the example the data records are numbered NO from one to five. Each data record is provided with the following: an Internet address URL of a service, for example "HTTP://XXX.YYY.FI/WAPSTATIC"; parameters PARAM associated with the service, such as "WORD=ECONOMY&STATUS=TRUE"; service priority PRI, such as "1"; and the name of the service
30 SERVICE_NAME, for example "ECONLEVELS". In the mobile communications system of the operator concerned the name of the service is unique, in other words, instead of a complex Internet address having possibly a changing end part, the service can be referred to in billing using only the identified, unique name of the service.

35 **[0038]** There are various ways of identifying the Internet address URL of a service. The identifying means 130, 132 may carry out the

identification on the basis of the parameters PARAM in the service's Internet address URL. For example, the service request comprises an address 200 which is "HTTP://XXX.YYY.FI/WAPSTATIC?WORD=ECONOMY&STATUS=TRUE".

[0039] In this case the identification means 130 pick the parameters
5 from the service's Internet address 200 on the basis of the separator characters placed between the parameters. In our example a question mark and an ampersand are used as separator characters, i.e. the question mark is followed by service parameters "WORD=ECONOMY" and "STATUS=TRUE". The identifier means 130 distinguish the names and values of the parameters
10 on the basis of separator characters placed between the parameter parts. In our example the separator is represented by the "=" sign, which means that the parameters can be shown in the form of table 202. In other words, there are two parameters in the example, the parameter name PARAM NAME of the first one being "WORD" and its value VALUE being "ECONOMY", and the
15 parameter name PARAM NAME of the second one being "STATUS" and its value VALUE "TRUE".

[0040] A comparison of the service parameters with the data records in the service identification table 132 produces a unique service name 204 which is "ECONLEVELS". A person skilled in the art will apparently study
20 various solutions for implementing the service identification table 132. Although in our example the stored parameters include the separator characters, other solutions are also possible; for example, each parameter could be stored as a separate data record part.

[0041] In a preferred embodiment the service priority PRI
25 determines the order in which the services in the service identification table 132 are checked. The priorities PRI are preferably set such that the service having the most parameters in one and the same Internet address URL enjoys the highest priority PRI, and the service having the fewest parameters in one and the same Internet address URL has the lowest priority PRI. For example,
30 if the Internet address 210 of the requested service is "HTTP://XXX.YYY.FI/WAPSTATIC?WORD=HIFI", two data records having the same domain name can be found in the service identification table 132, i.e. the data records shown in table 212. Data record number three which has the higher priority "1" is first compared with the Internet address 210. The
35 comparison shows that it does not have a second parameter with a name "PARAM1" and value "PRICES". Next, a data record number 4 having a lower

priority "2" is compared with the Internet address 210, whereby it is found that the only parameter in the request, i.e. parameter "WORD" having the value "HIFI" is in data record four. Consequently, the name 214 of the requested service is "HIFI-TOPICS". If the service priorities had been other way round, a
5 wrong service might have been identified by mistake, depending of course on the comparison rules applied to the service identification table. The use of priorities allows similar Internet addresses to be used for services, reducing at the same time the number of parameters required.

[0042] If the service is not identifiable or the use of service
10 parameters and possibly priorities is not feasible for identifying it, then the identifying means 130 identify the service on the basis of its Internet address URL. If the Internet address 220 of the service referred to in the service request is "HTTP://WAP.WEATHERSERVICES.FI/SONERA/RESULT.CGI", the service cannot be identified using parameters because the request
15 contains none. In this case the routine goes through the service identification table 132 until record number five 222 is found on the basis of which the name 224 of the service is identified to be "WEATHER".

[0043] Sometimes several requests are received for one and the same service. However, all service requests are not necessarily subject to a
20 charge. Service requests free of charge may be generated for example from different menu structures of a service and the related transition displays. In such cases the service identification table 132 preferably only comprises Internet addresses (URL) of services subject to a charge. For example, let us assume that the WAP Gateway receives the following service requests from a
25 subscriber terminal:

<http://xxx.yyy.fi:8080/CalendarTicket/2000515a.wbmp>

<http://xxx.yyy.fi:8080/TransactionTicket%/2000515b.wbmp>

<http://xxx.yyy.fi:8080/CalendarTicket/2000515c.wbmp>.

[0045] The service involves the transfer of three files,
30 2000515a.wbmp, 2000515b.wbmp and 2000515c.wbmp, to the subscriber terminal. The files in question are image files forming a single calendar page on the subscriber terminal display. However, instead of billing each part of the service separately, the service is to be billed only once. The service identification table 132 is therefore configured to provide only one data record
35 for the transactions to be billed, the data record being identified using for example a separately titled directory. The use of a separately titled directory

allows the name of the file to be changed, if necessary, whereas the name of the directory remains unchanged. This facilitates the updating of the contents of the services. The described method allows transactions subject to a charge to be separated from those free of charge. Alternatively, transactions subject to a charge could be identified using a separate parameter indicating billing validity. However, when several transactions are involved, this would unnecessarily increase the amount of data to be transferred. For example, if the Internet address 230 of the requested service is "HTTP://WAP.HEL.FI/TRANSACTIONTICKET%/2000515B.WBMP", the Internet address 230 of the service concerned is first cut by leaving out the file name whereby the name 232 of the directory accommodating the service is obtained, the contents of the name being "HTTP://WAP.HEL.FI/TRANSACTIONTICKET%". A comparison of the name 232 of the directory accommodating the service with the contents of the service identification table 132 produces a data record 234, i.e. record number six, in which the Internet service address URL is the same up to the truncation character. Consequently, the name 236 of the service requested is "CALENDAR". In the above example, the address is cut at a specific truncation character placed into the Internet address which in this case is the "%" sign used in the SQL (Structured Query Language) of Oracle® database. It is obvious to a person skilled in the art that there are also other ways to cut the address.

[0046] Finally, we shall refer to a flow chart shown in Figure 4 to describe a method for generating billing data in the mobile communications system employing the wireless application protocol. Reference is also made to Figure 3 which is a signal sequence diagram illustrating messages transferred in the mobile communications system employing the wireless application protocol.

[0047] The execution of the method starts at block 400. In block 402 a bi-directional wireless data transmission connection is set up to a subscriber terminal of the mobile communications system.

[0048] In block 404 a service request sent by the subscriber terminal is transmitted to a contents server providing the service. In other words, a request 300 is transmitted 320 to a network part 302 where it is received and routed 322 to the contents server 314. In the contents server 324 the request is transmitted 316 to the actual contents production means 316

which may be implemented in the same way as the actual WAP gateway, i.e. as a suitable combination of hardware and software.

[0049] Next, in block 406 response data generated in the contents server on the basis of the service request is transmitted to the subscriber terminal. In other words, the contents produced using the contents production means 316 in the signal sequence diagram is transmitted 326 to reception means 312, i.e. in practice often to the WAP Gateway, of the network part.

[0050] In block 408 transactions associated with the service concerned are identified from among the service requests and response data on the basis of the identification of the Internet address of the service referred to in the service request and the response data. Finally, the transactions identified on the basis of the service's Internet address are used in block 410 to generate the billing data of the service. In other words, the identifying means 306 are used in the signal sequence diagram 3 to identify the transactions after which the WAP gateway 308 is informed 330 that the response data for the service may be sent 332 to the subscriber terminal 302. When the transactions have been identified, they may be reported 334 to the billing system 310 for producing the bill. As will be shown in the appended claims, the method can be modified using the preferred embodiments described in connection with the network part.

[0051] Although the invention is described above with reference to an example according to the accompanying drawings, it is apparent that the invention is not restricted to it, but may vary in many ways within the inventive idea disclosed in the accompanying claims.

CLAIMS

1. A network part of a mobile communications system employing a wireless application protocol, comprising:

5 means (104, 106, 118) for setting up a bi-directional wireless data transmission connection (102) to a subscriber terminal (100) of the mobile communications system;

means (126) for transmitting a service request (150, 152) sent by the subscriber terminal (100) to a contents server (136) providing the service;

10 means (126) for transmitting response data (154, 156, 158, 160) generated in the contents server (136) on the basis of the service request (150, 152) to the subscriber terminal (100);

characterized in that the network part further comprises

15 identifying means (130, 132) for identifying transactions associated with the service from among the service requests (150, 152) and the response data (154, 156, 158, 160) on the basis of the identification of the Internet address of the service referred to in the service request (150, 152) and the response data (154, 156, 158, 160);

billing means (134) for generating billing data for the service using the transactions identified on the basis of the service's Internet address.

20 2. A network part according to claim 1, wherein the identifying means (130, 132) carry out the identification on the basis of service parameters placed into the Internet address of the service.

25 3. A network part according to claim 2, wherein the identifying means (130) pick the parameters from the service's Internet address on the basis of separator characters placed between the parameters.

4. A network part according to claim 2, wherein the identifying means (130) distinguish the parameters names and values on the basis of separator characters placed between them.

30 5. A network part according to any one of the preceding claims, wherein the identifying means (130, 132) comprise a service identification table (132) which comprises a service name (SERVICE NAME), Internet address (URL), service parameters (PARAM) and service priority (PRI) for each service.

6. A network part according to claim 5, wherein the service priority (PRI) determines the order in which the services in the service identification table (132) are checked.

5 7. A network part according to claim 6, wherein the priorities (PRI) are set such that the service having the most parameters in one and the same Internet address (URL) enjoys the highest priority (PRI), and the service having the fewest parameters in one and the same Internet address (URL) has the lowest priority (PRI).

10 8. A network part according to any one of the preceding claims, wherein the identifying means (130) carry out the identification on the basis of the service's Internet address (URL).

9. A network part according to any one of the preceding claims, wherein the service identification table (132) only comprises Internet addresses of services subject to a charge.

15 10. A method for generating billing data in a mobile communications system employing a wireless application protocol, the method comprising the steps of

(402) setting up a bi-directional wireless data transmission connection to a subscriber terminal of the mobile communications system;

20 (404) transmitting a service request sent by the subscriber terminal to a contents server providing the service;

(406) transmitting response data generated in the contents server on the basis of the service request to the subscriber terminal;

25 **characterized** in that the method further comprises the steps of

(408) identifying transactions associated with the service from among the service requests and the response data on the basis of the identification of the Internet address of the service referred to in the service request and the response data;

30 (410) generating billing data for the service using the transactions identified on the basis of the service's Internet address.

11. A method according to claim 10, wherein the identifying means carry out the identification on the basis of service parameters placed into the Internet address of the service.

12. A method according to claim 11, wherein the identifying means pick the parameters from the service's Internet address on the basis of separator characters placed between the parameters.

5 13. A method according to claim 11, wherein the identifying means distinguish the parameter names and values on the basis of separator characters placed between them.

10 14. A method according to any one of the preceding claims 10 to 13, wherein the identifying means comprise a service identification table which comprises a service name, Internet address, service parameters and service priority for each service.

15 15. A method according to claim 14, wherein the service priority determines the order in which the services in the service identification table are checked.

15 16. A method according to claim 15, wherein the priorities are set such that the service having the most parameters in one and the same Internet address enjoys the highest priority, and the service having the fewest parameters in one and the same Internet address has the lowest priority.

20 17. A method according to any one of the preceding claims 10 to 16, wherein the identifying means carry out the identification on the basis of the service's Internet address.

18. A method according to any one of the preceding claims 10 to 17, wherein the service identification table only comprises Internet addresses of services subject to a charge.

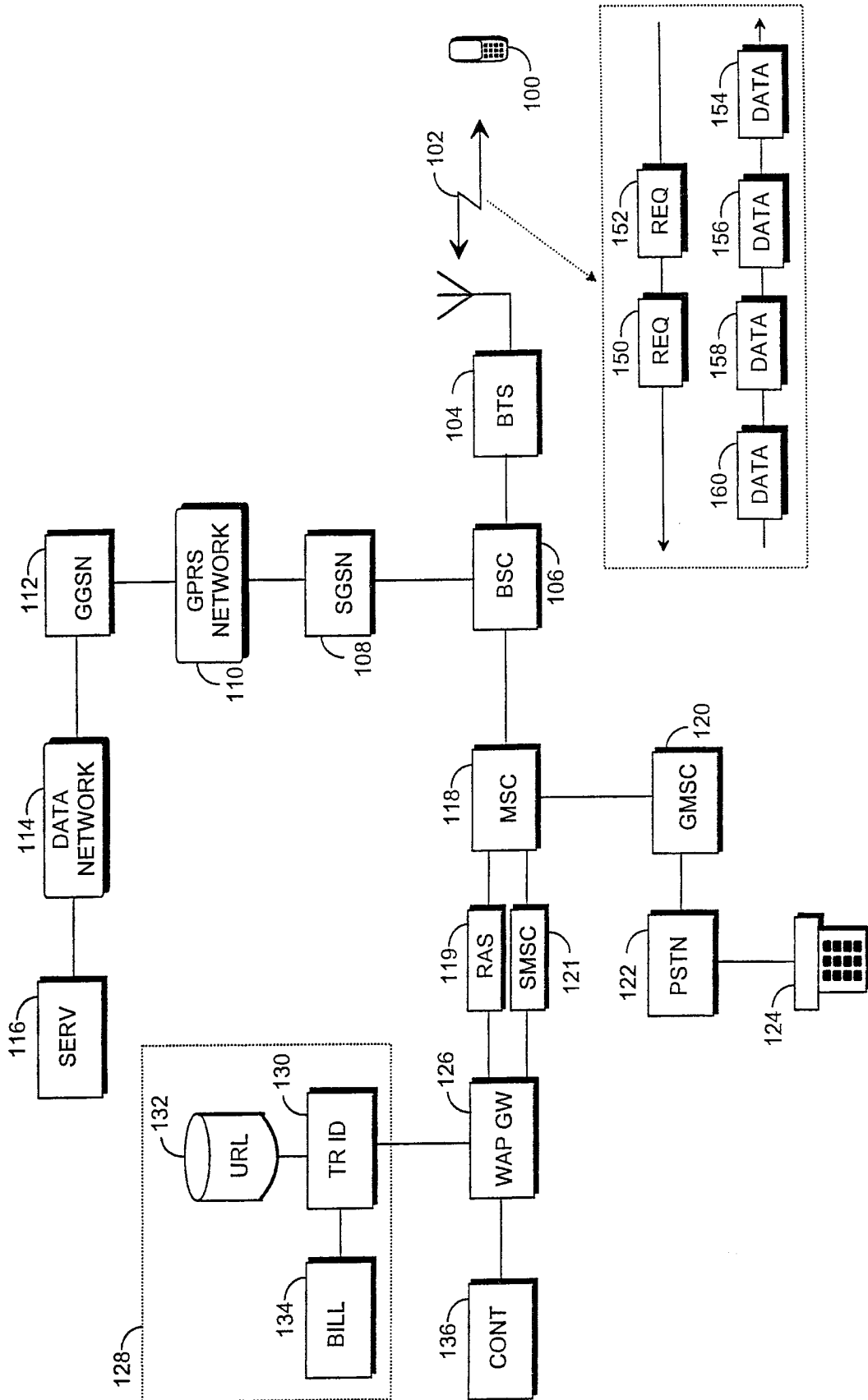

Fig 1

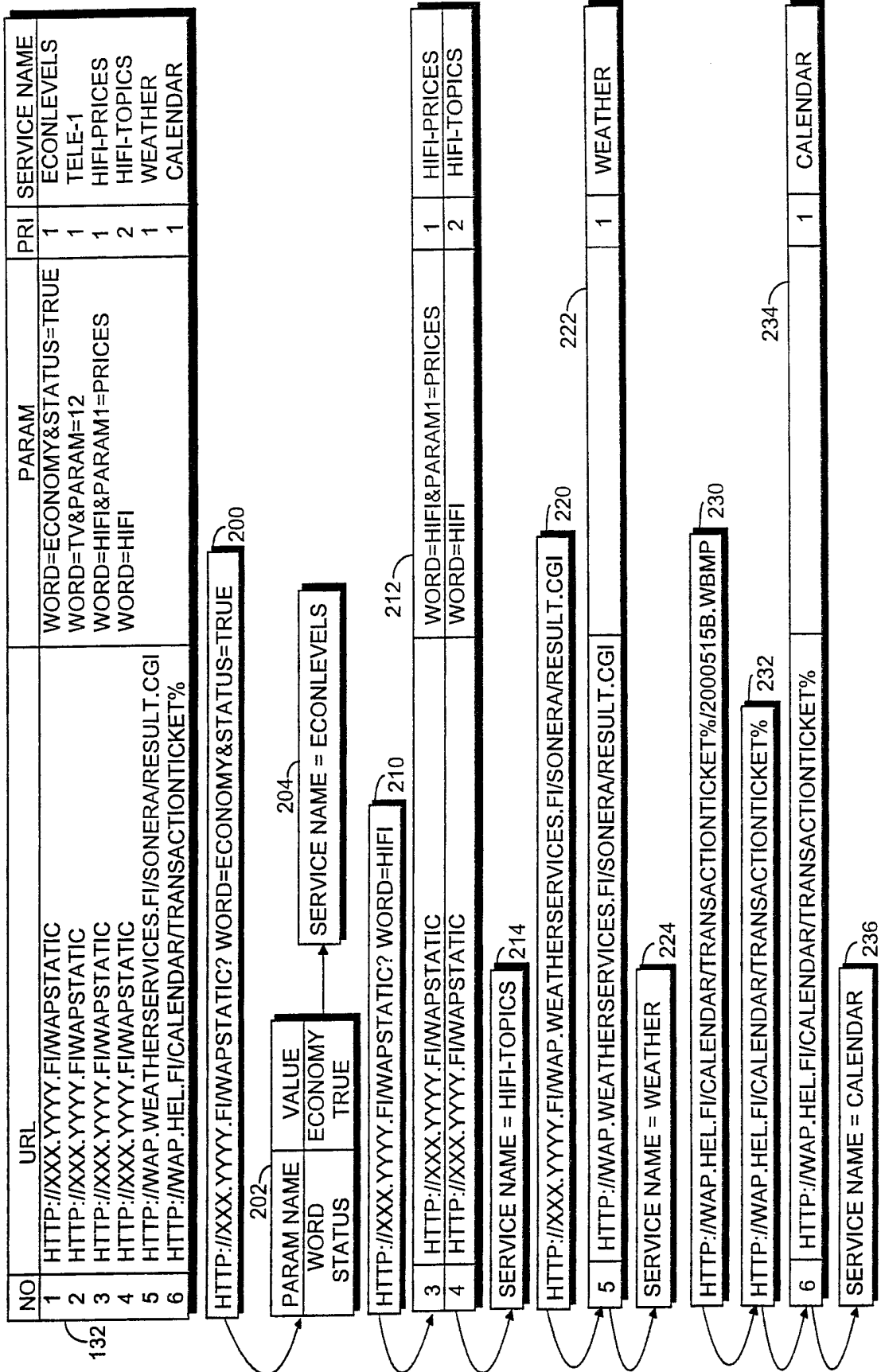

Fig 2

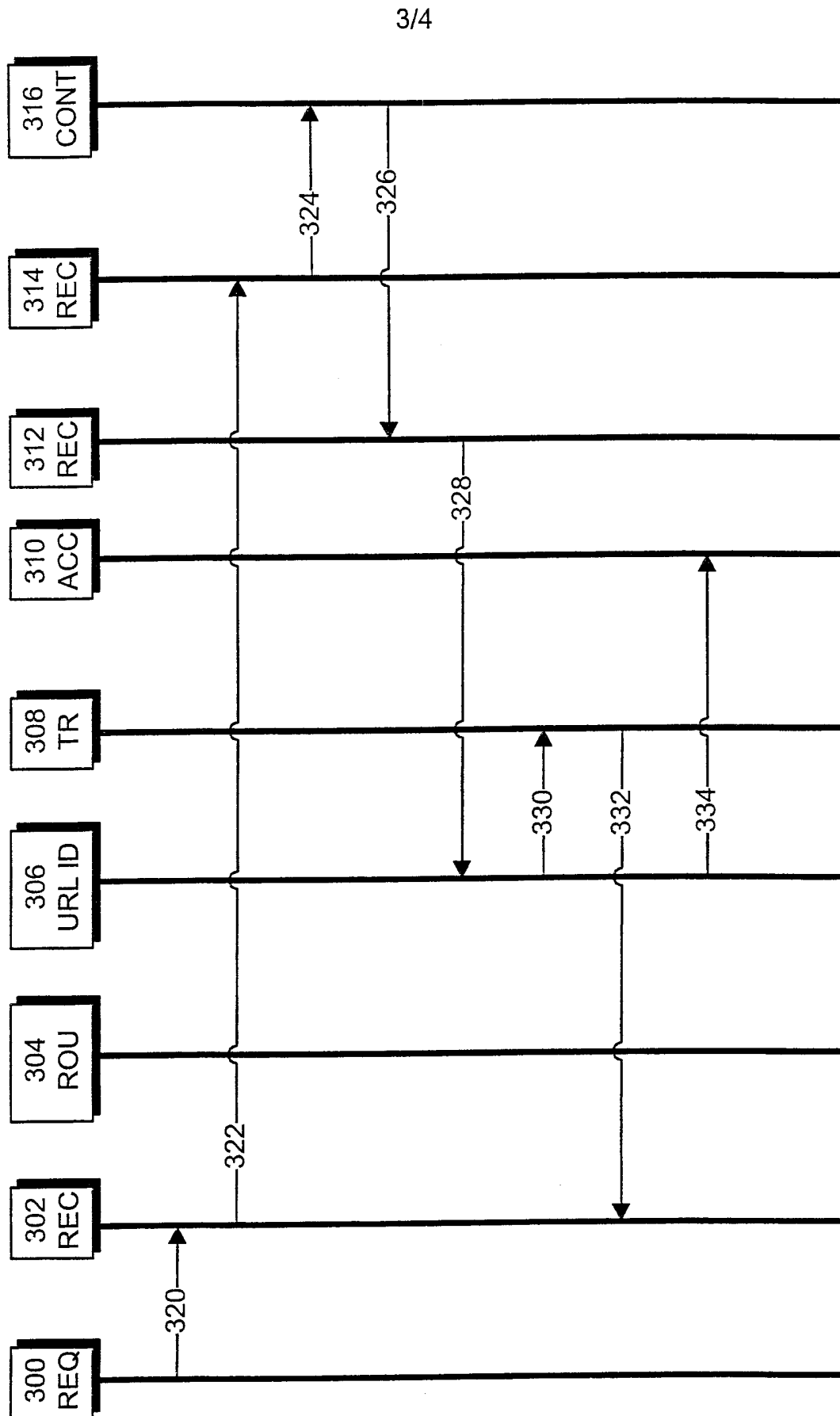

Fig 3

4/4

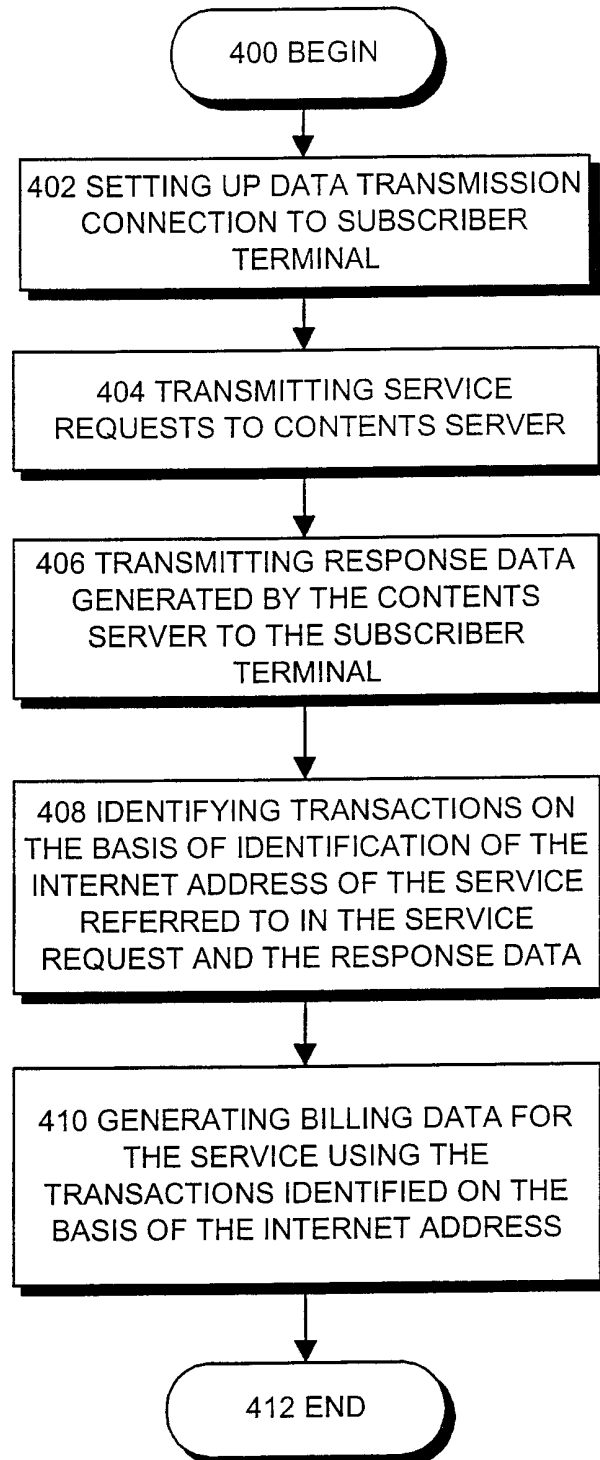

Fig 4

INTERNATIONAL SEARCH REPORT

International application No.

PCT/FI 01/00243

A. CLASSIFICATION OF SUBJECT MATTER

IPC7: H04M 3/42, H04Q 7/22

According to International Patent Classification (IPC) or to both national classification and IPC

B. FIELDS SEARCHED

Minimum documentation searched (classification system followed by classification symbols)

IPC7: H04M, H04Q

Documentation searched other than minimum documentation to the extent that such documents are included in the fields searched

SE,DK,FI,NO classes as above

Electronic data base consulted during the international search (name of data base and, where practicable, search terms used)

C. DOCUMENTS CONSIDERED TO BE RELEVANT

Category*	Citation of document, with indication, where appropriate, of the relevant passages	Relevant to claim No.
X	EP 0817452 A2 (AT & T CORP.), 7 January 1998 (07.01.98), column 4 - column 6 -- -----	1-18

 Further documents are listed in the continuation of Box C. See patent family annex.

* Special categories of cited documents:

"A" document defining the general state of the art which is not considered to be of particular relevance

"E" earlier application or patent but published on or after the international filing date

"L" document which may throw doubts on priority claim(s) or which is cited to establish the publication date of another citation or other special reason (as specified)

"O" document referring to an oral disclosure, use, exhibition or other means

"P" document published prior to the international filing date but later than the priority date claimed

"T" later document published after the international filing date or priority date and not in conflict with the application but cited to understand the principle or theory underlying the invention

"X" document of particular relevance: the claimed invention cannot be considered novel or cannot be considered to involve an inventive step when the document is taken alone

"Y" document of particular relevance: the claimed invention cannot be considered to involve an inventive step when the document is combined with one or more other such documents, such combination being obvious to a person skilled in the art

"&" document member of the same patent family

Date of the actual completion of the international search

29 June 2001

Date of mailing of the international search report

03 -07- 2001

Name and mailing address of the ISA/

Swedish Patent Office

Box 5055, S-102 42 STOCKHOLM

Facsimile No. +46 8 666 02 86

Authorized officer

Stefan Hansson/JAn

Telephone No. +46 8 782 25 00

INTERNATIONAL SEARCH REPORT
Information on patent family members

28/05/01

International application No.
PCT/FI 01/00243

Patent document cited in search report	Publication date	Patent family member(s)	Publication date
EP 0817452 A2	07/01/98	CA 2205748 A	28/12/97
		JP 10093629 A	10/04/98
