

(19) World Intellectual Property Organization
International Bureau



(43) International Publication Date
13 September 2007 (13.09.2007)

PCT

(10) International Publication Number
WO 2007/103236 A2

- (51) International Patent Classification:
A61F 2/86 (2006.01)
- (21) International Application Number:
PCT/US2007/005471
- (22) International Filing Date: 2 March 2007 (02.03.2007)
- (25) Filing Language: English
- (26) Publication Language: English
- (30) Priority Data:
60/778,400 3 March 2006 (03.03.2006) US
- (71) Applicant (for all designated States except US): **PRE-SCIENT MEDICAL, INC.** [US/US]; 2005 South Easton Road, Suite #204, Doylestown, PA 18901 (US).
- (72) Inventor; and
- (75) Inventor/Applicant (for US only): **KULA, John** [US/US]; 273 Colorado Drive, Birdsboro, PA 19508 (US).
- (74) Agents: **FRANK, Michele Van Patten et al.**; Patton Boggs Llp, 8484 Westpark Drive, Suite 900, Mclean, VA 22102 (US).
- (81) Designated States (unless otherwise indicated, for every kind of national protection available): AE, AG, AL, AM,

AT, AU, AZ, BA, BB, BG, BR, BW, BY, BZ, CA, CH, CN, CO, CR, CU, CZ, DE, DK, DM, DZ, EC, EE, EG, ES, FI, GB, GD, GE, GH, GM, GT, HN, HR, HU, ID, IL, IN, IS, JP, KE, KG, KM, KN, KP, KR, KZ, LA, LC, LK, LR, LS, LT, LU, LY, MA, MD, MG, MK, MN, MW, MX, MY, MZ, NA, NG, NI, NO, NZ, OM, PG, PH, PL, PT, RO, RS, RU, SC, SD, SE, SG, SK, SL, SM, SV, SY, TJ, TM, TN, TR, TT, TZ, UA, UG, US, UZ, VC, VN, ZA, ZM, ZW.

(84) Designated States (unless otherwise indicated, for every kind of regional protection available): ARIPO (BW, GH, GM, KE, LS, MW, MZ, NA, SD, SL, SZ, TZ, UG, ZM, ZW), Eurasian (AM, AZ, BY, KG, KZ, MD, RU, TJ, TM), European (AT, BE, BG, CH, CY, CZ, DE, DK, EE, ES, FI, FR, GB, GR, HU, IE, IS, IT, LT, LU, LV, MC, MT, NL, PL, PT, RO, SE, SI, SK, TR), OAPI (BF, BJ, CF, CG, CI, CM, GA, GN, GQ, GW, ML, MR, NE, SN, TD, TG).

Declaration under Rule 4.17:

— as to the identity of the inventor (Rule 4.17(i))

Published:

— without international search report and to be republished upon receipt of that report

For two-letter codes and other abbreviations, refer to the "Guidance Notes on Codes and Abbreviations" appearing at the beginning of each regular issue of the PCT Gazette.

(54) Title: ENDOLUMINAL PROSTHESES FOR TREATING VULNERABLE PLAQUE

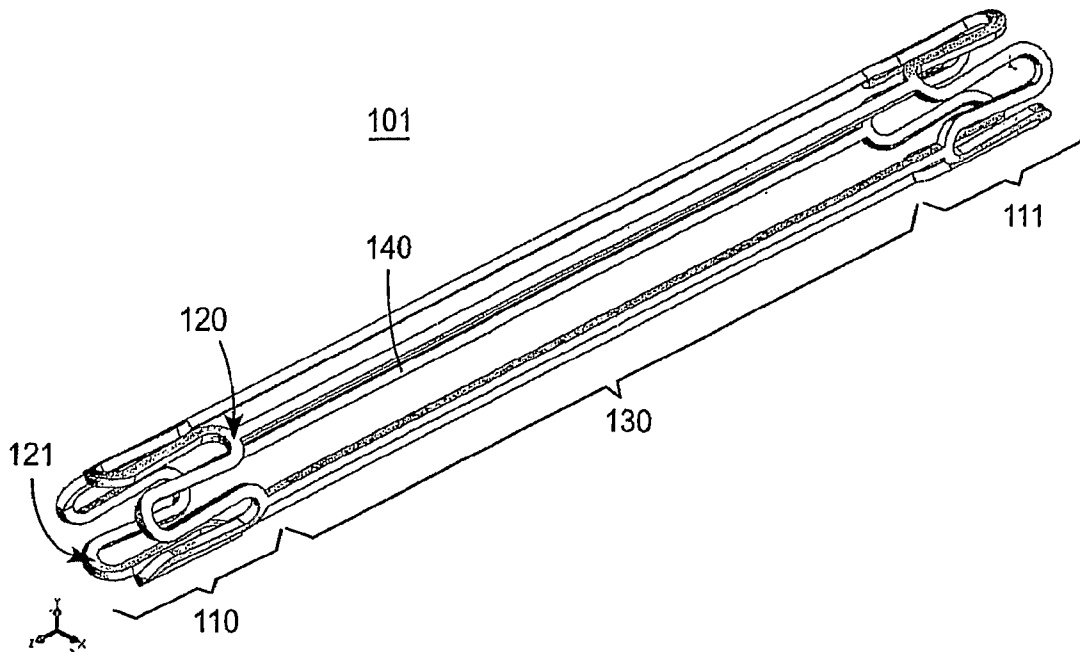

(57) Abstract: The invention provides expandable tubular endoluminal prostheses for the treatment of vulnerable plaque lesions and methods for treating vulnerable plaques using the prostheses. The endoprosthesis may include at least two opposing ring-like end sections and a central section including a number of struts having parallel longitudinal axes connecting the ends sections. In use, the device is expanded in a blood vessel so that the central section at least partially contacts a vulnerable plaque lesion and/or the blood vessel wall in close proximity to the vulnerable plaque lesion.

WO 2007/103236 A2

ENDOLUMINAL PROSTHESES FOR TREATING VULNERABLE PLAQUE

[0001] This application claims priority to U.S. provisional patent application serial no. 60/788,400 filed March 3, 2006, which is incorporated herein by reference in its entirety.

5 FIELD OF THE INVENTION

[0002] The invention relates generally to the fields of expandable endoluminal vascular prostheses and their use in treating atherosclerotic lesions.

BACKGROUND OF INVENTION

[0003] Vulnerable plaques, which are sometimes known as high-risk atherosclerotic
10 plaques, include arterial atherosclerotic lesions characterized by a subluminal thrombotic lipid-rich pool of materials contained by and/or overlaid by a thin fibrous cap. Although vulnerable plaques are non-stenotic or nominally stenotic, it is believed that their rupture, resulting in the release of thrombotic contents, accounts for a significant fraction of adverse cardiac events.

15 [0004] U.S. Publication No. 2002/0004679 discloses drug eluting polymer stents for treating restenosis with topoisomerase inhibitors, and is incorporated herein by reference in its entirety.

[0005] U.S. Publication No. 2002/0125799 discloses intravascular stents for the treatment
20 of vulnerable plaque that consist of opposing end ring portions and a central strut portion having a zig-zag configuration that connects with the end portion at apices of the zig-zag structure, and is incorporated herein by reference in its entirety. The particular zig-zag structure of the stent tends to cause substantial foreshortening upon radial expansion of the device.

[0006] U.S. Publication No. 2005/0137678 discloses a low-profile resorbable polymer
25 stent and compositions therefore, and is incorporated herein by reference in its entirety.

[0007] U.S. Publication No. 2005/0287184 discloses drug-delivery stent formulations for
treating restenosis and vulnerable plaque, and is hereby incorporated by reference herein in its entirety.

SUMMARY OF INVENTION

30 [0008] The present invention provides tubular endoluminal prostheses and methods for treating vulnerable plaque therewith.

[0009] One embodiment of the invention provides a tubular endovascular prosthesis for the treatment of vulnerable plaque, that includes: at least two sinuate annular sections, each having a common central axis; wherein the prosthesis has two opposite ends with one of the

sinuate annular sections disposed at each of the ends; and a plurality of struts having parallel longitudinal axes with each other and connecting adjacent sinuate annular sections to each other.

5 [00010] A related embodiment of the invention provides a tubular endovascular prosthesis for the treatment of vulnerable plaque, that includes: two sinuate annular end sections at opposite ends of the endoprosthesis; and a center section including a plurality of struts having parallel longitudinal axes with each other, wherein the struts connect the opposite end sections.

10 [00011] A further embodiment of the invention provides a method for treating vulnerable plaque in a patient in need thereof, comprising the step of: deploying an endoprosthesis according to the invention at a site of a vulnerable plaque in blood vessel of a patient. The endoprosthesis may be covered or uncovered. The endoprosthesis may be coated or uncoated.

15 [00012] Additional features, advantages, and embodiments of the invention may be set forth or apparent from consideration of the following detailed description, drawings, and claims. Moreover, it is to be understood that both the foregoing summary of the invention and the following detailed description are exemplary and intended to provide further explanation without limiting the scope of the invention as claimed.

BRIEF DESCRIPTION OF THE DRAWINGS

20 [00013] FIG. 1 shows an embodiment of a prosthesis according to the invention in which straight struts having longitudinal axes parallel to the longitudinal axis of the tubular shape of the prosthesis connect two sinuate end sections.

25 [00014] FIG. 2 shows an embodiment of a prosthesis according to the invention having sinuate struts with a 60-deg angle between adjacent straight segments and longitudinal axes parallel to the longitudinal axis of the tubular shape of the prosthesis.

[00015] FIG. 3 shows an embodiment of a prosthesis similar to that shown in FIG. 2, except that in FIG. 3 the adjacent straight segments of the sinuate struts are separated by a 90-deg angle.

[00016] FIG. 4 shows the embodiment of FIG. 1 in a radially expanded state.

30 [00017] FIG. 5 shows an embodiment of a prosthesis according to the invention having straight struts that are interrupted by s-shaped curves to promote flexibility. In addition, the longitudinal axes of the struts do not perpendicularly intersect the transverse plane of annular end segments (as shown); instead, they are diagonally angled.

DETAILED DESCRIPTION

[00018] The invention provides tubular endovascular prostheses for the treatment of atherosclerotic lesions, including vulnerable plaques, and methods of treatment using the endoprosthesis therefor.

[00019] One embodiment of the invention provides a tubular endovascular prosthesis for the treatment of atherosclerosis lesions such vulnerable plaques, that includes: at least two sinuate annular sections, each having a common central axis; wherein the prosthesis has two opposite ends with one of the sinuate annular sections disposed at each of the ends; and a plurality of struts having parallel longitudinal axes with each other and connecting adjacent sinuate annular sections to each other. The sinuate annular sections resemble a filament or band that undulates back and forth as a path is formed over the surface of a cylinder. The prosthesis is preferably expandable so that its radius can be increased to contact the wall of blood vessel. The prosthesis may be balloon-expandable and/or self-expanding. In one embodiment, the prosthesis is balloon expandable at a pressure of 3 ATMs or less. In another embodiment, the prosthesis is self-expanding by virtue of being composed of a shape-memory metal alloy or a shape-memory polymer. The endoluminal prostheses of the present invention do not need to have the hoop strength and radial resiliency that is required by conventional stents that are used in conjunction with angioplasty procedures to prevent restenosis. Accordingly, endoprosthesis of the invention may have or lack such hoop strength and resiliency, and may be of a lighter construction than conventional stents.

[00020] In one variation of the embodiment, the longitudinal axes of the struts are parallel to the longitudinal axis of the endoprosthesis. The struts may connect to the sinuate annular sections at the centrally-facing curve peaks of the sinuate annular sections.

[00021] A related embodiment of the invention provides a tubular endovascular prosthesis for the treatment of atherosclerosis lesions such vulnerable plaques, that includes: two sinuate annular end sections at opposite ends of the endoprosthesis; and a center section including a plurality of struts having parallel longitudinal axes with each other, wherein the struts connect the opposite end sections. Each of the end section may, for example, be formed by a single sinuate form. In one variation of the embodiment, the struts connect to the end sections at peaks of the sinuate form. The longitudinal axes of the struts may also parallel to the longitudinal axis of the tubular shape of the prosthesis.

[00022] Various aspects of the invention are described below with reference to the appended figures.

[00023] FIG. 1 shows an embodiment of an expandable endoprosthesis 101 that has two sinuate annular end sections 110 and 111 at opposite ends of the device. The end sections

110 and 11 are separated by a central section 130 that is composed of straight struts, for example 140, that connect to the end sections 110 and 111. Each end section has the form of an undulating filament or band that wraps around the shape of a tube as it undulates, thereby forming an annular ring. The outward most part of the curves, for example, 120 and 121, formed by the undulations are referred to as curve peaks herein. The straight struts connect to the more centrally-located curve peaks of the end sections. In the embodiment shown, the longitudinal axes of the struts are parallel to one another and to the central longitudinal axes of the annular end sections. The straight struts of the embodiment attach to the middle of the curve peaks in an essentially perpendicular manner. In the endoprosthesis shown in FIG. 1, every one of the centrally-located curve peaks is connected to an associated strut. However, embodiments in which not every centrally located curve peak has an attached strut are also provided by the invention.

[00024] In contrast to the particular zig-zag strut geometry of the stents described in U.S. Publication No. 2003/0125799, the straight strut designs of the present embodiment and various other embodiments of the present invention tend to limit foreshortening of the endoprosthesis during radial expansion.

[00025] FIG. 2 shows a section of an embodiment 201 of an expandable prosthesis according to the invention in which the struts, for example 240, of the central section 230 are sinuate struts, having a 60-deg angle between adjacent straight segments of the sinuate struts. The dimensions shown in the figure are in inches. The longitudinal axes of the struts are parallel to each other and are also parallel to the longitudinal axis of the tubular shape of the prosthesis. In the embodiment of FIG. 2, the sinuate curves of the different struts of the center section 230 are longitudinally in-phase. The invention also provides embodiments in which at least part of the sinuate curves of struts of the central section are not all in phase. For example, the invention provides an embodiment in which the longitudinal phases of at least two adjacent struts are opposite one another so that a continuous hour glass-shaped path is formed between the adjacent struts. The struts such as 240 connect with the curve peaks of the end sections, but since the struts themselves are sinuate in prosthesis 201, the connection angle is not perpendicular.

[00026] FIG. 3 shows a section of an embodiment of a prosthesis 301 similar to that shown in FIG. 2, except that the sinuate struts of the device in FIG. 3 have a 90-deg angle between adjacent straight segments. The dimensions shown in FIG. 3 are also in inches.

[00027] FIG. 4 shows the prosthesis of FIG. 1 in its expanded state 401.

[00028] FIG. 5 shows a section of an embodiment of a prosthesis 501 according to the invention having straight struts that are interrupted by s-shaped curves, for example 590 and 591, to promote flexibility with respect to the axis of the device. As shown, each strut has two s-shaped segments interrupting the straight form of the strut. Generally, a strut may optionally have one or more sinuate forms along its length in order to promote flexibility of the strut and the overall prosthesis. In addition, the longitudinal axes of the struts in this embodiment do not perpendicularly intersect the transverse plane of annular end segments (as shown); instead they are diagonally angled. Also, the section of a strut directly connecting to a sinuate annular section (a "connecting section"), for example 592 and 593, is narrowed with respect to the main portions of the strut. In one variation the width of the s-shape curve elements and the connecting sections is about 40% of the width of the main portions of the strut. The diagonal struts, sinuate interruptions, and narrowed connecting sections are separate features that may occur together or separately in various embodiments of the invention. The dimensions shown in FIG. 5 are in inches.

[00029] The endoprostheses shown in FIGS. 1-5 each have only two sinuate annular sections, which are disposed at the opposing ends of the device. Thus, the invention provides embodiments in which neighboring longitudinal strut elements are not at all, or are at least substantially not, interconnected (to each other) between the sinuate annular end sections. However, the invention also provides embodiments in which there is at least one additional sinuate annular section located between the sinuate annular end sections. In this case, adjacent sinuate annular sections may be connected to each other by struts in the same manner as described above.

[00030] The longitudinal length of prostheses according to the invention may, for example, be in the range of 0.5 to 1.0 inch (approximately 1.27 to 2.54 cm), such as 0.716 inch (approximately 1.819 cm). The width of the longitudinal strut elements of any of the embodiment may, for example, be about 0.005 inch (about 0.0127 cm), such as 0.005 inch (approximately 0.0127 cm). When the width of the longitudinal strut elements of the embodiment of FIG. 5 is about 0.005 inch (about 0.0127 cm), the width of each of the s-shaped curves, for example 590 and 591, and the narrowed connecting sections, for example 592 and 593, of the strut elements, may for example be about 0.002 inch (about 0.00508 cm).

[00031] A further embodiment of the invention provides a method for treating vulnerable plaque in a patient in need thereof that includes the step of deploying any of the prostheses described herein at the site of a vulnerable plaque lesion in the patient. Preferably, the strut sections of the device are positioned so that they at least partially traverse a section of blood

vessel that has the vulnerable plaque lesion. The deployment involves an expansion of the radius of the device to that the end sections and the strut sections come into contact with the vessel wall. At least one of the strut sections may contact the fibrous cap of the vulnerable plaque and/or at least one strut section may contact the vessel wall in the vicinity of the vulnerable plaque lesion. In either case, contact with the vessel wall promotes endothelialization and remodeling of at least the luminal face of the vulnerable plaque lesion. The invention also provides a general method of promoting endothelialization in a region of a blood vessel by deploying a prosthesis according to the invention in the region, irrespective of the underlying pathology of the blood vessel in the region.

[00032] The endoprosthesis may be delivered in a decreased radius configuration on a delivery catheter. The endoprosthesis may be crimped on or otherwise positioned around an inflatable deployment balloon, so that expansion of the balloon at least partially expands the endoprosthesis to its final working radius. For self-expanding versions of the endoprosthesis, use of a delivery balloon is optional. A self-expanding prosthesis may, for example, be restrained in a cylindrical cavity covered by a restraining sheath and deployed by retracting the sheath, as known in the art.

[00033] An inflatable deployment balloon of a catheter delivery device may, for example, be at least substantially cylindrically-shaped or it may have a different shape. A deployment balloon may that is more expansive or expands with more force in the regions of the annular sinuate segments and less in the strut segment region(s) may, for example be used, to prevent over-expansion or distension of the struts section. A dumbbell-shaped balloon may, for example, segment in-between, where the enlarged ends of the balloon are designed to expand the annular end segments of the prosthesis. In one embodiment, a single balloon or multiple balloons are used to expand the annular segments but the struts segment(s) is expanded at least predominantly only by expansion of the end segments. In still another embodiment, separate balloons are used to expand the struts segment and the annular segments. In this manner the expansion of struts segments and annular segment can be separately controlled.

[00034] Any of the treatment methods of the invention may include a step of locating an atherosclerotic lesion, such as a vulnerable plaque lesion, to be treated by the endoprosthesis in a patient.

[00035] According to the invention, determining the location of a vulnerable plaque or other type of atherosclerotic lesion in a blood vessel of a patient can be performed by any method or combination of methods. For example, catheter-based systems and methods for

diagnosing and locating vulnerable plaques can be used, such as those employing optical coherent tomography ("OCT") imaging, temperature sensing for temperature differentials characteristic of vulnerable plaque versus healthy vasculature, labeling/marking vulnerable plaques with a marker substance that preferentially labels such plaques, infrared elastic scattering spectroscopy, and infrared Raman spectroscopy (IR inelastic scattering spectroscopy). U.S. Publication No. 2004/0267110 discloses a suitable OCT system and is hereby incorporated by reference herein in its entirety. Raman spectroscopy-based methods and systems are disclosed, for example, in: U.S. Patent Nos. 5,293,872; 6,208,887; and 6,690,966; and in U.S. Publication No. 2004/0073120, each of which is hereby incorporated by reference herein in its entirety. Infrared elastic scattering based methods and systems for detecting vulnerable plaques are disclosed, for example, in U.S. Patent No. 6,816,743 and U.S. Publication No. 2004/0111016, each of which is hereby incorporated by reference herein in its entirety. Temperature sensing based methods and systems for detecting vulnerable plaques are disclosed, for example, in: U.S. Patent Nos. 6,450,971; 6,514,214; 6,575,623; 6,673,066; and 6,694,181; and in U.S. Publication No. 2002/0071474, each of which is hereby incorporated herein in its entirety. A method and system for detecting and localizing vulnerable plaques based on the detection of biomarkers is disclosed in U.S. Patent No. 6,860,851, which is hereby incorporated by reference herein in its entirety. Angiography using a radiopaque and/or fluorescent dye, for example, as known in the art, may be performed before, during and/or after the step of determining the location of the vulnerable plaque, for example, to assist in positioning the prosthesis in a subject artery.

[00036] The prostheses of the invention may be metallic and/or polymeric in composition.

[00037] Metals used to manufacture a prosthesis according to the invention include, but are not limited to stainless steel, titanium, titanium alloys, platinum and gold. Shape-memory metal alloys may be used to produce self-expanding versions of endoprostheses according to the invention. For example, suitable shape-memory alloys include, but are not limited, to Nitinol and Elgiloy.

[00038] Polymers used for the manufacture of endoprostheses according to the invention may be biodegradable or non-biodegradable. Any suitable sorts of biodegradable polymers and/or biodegradable polymer blends may be used according to the invention. As used herein, the term "biodegradable" should be construed broadly as meaning that the polymer(s) will degrade once placed within a patient's body. Accordingly, biodegradable polymers as referred also include bioerodable and bioresorbable polymers. Suitable types of polymer material include, but are not limited to, polyester, polyanhydride, polyamide, polyurethane,

polyurea, polyether, polysaccharide, polyamine, polyphosphate, polyphosphonate, polysulfonate, polysulfonamide, polyphosphazene, hydrogel, polylactide, polyglycolide, protein cell matrix, or copolymer or polymer blend thereof.

5 [00039] Homopolymers of polylactic acid (PLA), for example PLLA, PDLA and poly(D,L,)lactic acid, stereopolymers thereof, and copolymer of PLA with other polymeric units such as glycolide provide a number of characteristics that are useful in a polymeric endoprosthesis for treating a lesion of a blood vessel such as a high risk atherosclerotic plaque (vulnerable plaque). First, polymers made of these components biodegrade in vivo into harmless compounds. PLA is hydrolyzed into lactic acid in vivo. Second, these 10 polymers are well suited to balloon-mediated expansion using a delivery catheter. Third, polymers made of these materials can be imparted with a shape-memory so that polymeric, at least partially self-expanding, tubular endoprostheses can be provided. Self-expanding polymeric prostheses according to the invention may also, for example, be at least partially balloon-expanded. Methods for producing biodegradable, polymeric shape-memory 15 endoprostheses are described, for example, in U.S. Patent Nos. 4,950,258, 5,163,952, and 6,281,262 each of which is incorporated by reference herein in its entirety.

[00040] Endoprostheses according to the invention may be manufactured by any suitable method. For example, a metallic endoprosthesis can be produced by laser cutting the device from a tubular blank. Methods for forming metallic tubular blanks are well known. For 20 example, sputtering metallic material onto a mandrel may be used. In another example, the shape of the endoprosthesis can be laser cut or stamped out of a flat sheet of metallic material and then formed and welded into a tubular configuration. Once formed into shape, metallic endoprostheses according to the invention may optional be electrochemically polished and/or etched. In one embodiment of the invention, a metallic prosthesis according to the invention 25 is manufactured by separately forming the sinuate annular sections and connecting the struts to the annular sections by, for example, welding or any suitable method for joining metallic components to each other. The sinuate annular sections may be formed separately by, for example, laser cutting from a metallic tubular blank or by winding a filament or band of the metallic material about a suitable cylindrical jig. The ends of such a jig-wound sinuate 30 annular section may be welded together to form a continuous ring structure.

[00041] The wall thickness of an endoprosthesis according to the invention may, for example, be in the range of about 20 microns to about 200 microns. In one embodiment, the wall thickness is equal to or less than 200 microns, for example, equal to or less than 125 microns. In one embodiment, the wall thickness is in the range of 20 microns to 125 microns.

In another embodiment of the invention, the wall thickness is in the range of 20 to 60 microns. In still another embodiment, the wall thickness is in the range of 50 to 100 microns.

[00042] A polymeric prosthesis according to the invention, such as one composed of polylactide, may also be laser cut from a tubular blank, such as one formed by extrusion molding.

[00043] Endoprostheses according to the invention may be provided with a polymeric, metallic or composite cover that surrounds at least part of the strut sections of the endoprosthesis. In one embodiment, irrespective of the composition of the body of the endoprosthesis, the cover may be polymeric and may, for example, be biodegradable in vivo.

The polymer cover may be self-expanding, for example as the result of a shape-memory characteristic. The cover may, for example, be thermoplastically expandable but not be self-expanding. The cover may be porous or non-porous. The cover may, for example, be a continuous porous or non-porous polymeric structure or it may be a braid, woven, or knit polymeric structure. In embodiment in which at least a portion of the strut section is covered, the cover rather than the underlying struts contact the vessel wall upon deployment of the device.

[00044] For polymeric endoprostheses, it may also be possible to blend one or more beneficial agents such as drugs with the polymer melt during the formation of an article. Metallic or non-metallic endoprostheses according to the invention may be coated with one or more polymer coatings. The coating(s) may optionally include or be loaded with beneficial agents such as drugs or other compounds useful for treating vulnerable and/or for facilitating the desired functioning of the implanted endoprosthesis, for example, anti-thrombotic agents such as heparin to inhibit endoprosthesis-induced thrombosis at the treatment site. U.S. Patent No. 5,624,411 teaches methods of coating intravascular stents with drugs, and is hereby incorporated by reference in its entirety.

[00045] Although the foregoing description is directed to the preferred embodiments of the invention, it is noted that other variations and modifications will be apparent to those skilled in the art, and may be made without departing from the spirit or scope of the invention. Moreover, features described in connection with one embodiment of the invention may be used in conjunction with other embodiments, even if not explicitly stated above.

WHAT IS CLAIMED IS:

1. A tubular prosthesis for the treatment of vulnerable plaque, comprising:
at least two sinuate annular sections, each having a common central axis; wherein the
5 prosthesis has two opposite ends with one of the sinuate annular sections disposed at each of
the ends; and
a plurality of struts having parallel longitudinal axes with each other and connecting
adjacent sinuate annular sections to each other.
- 10 2. The prosthesis of claim 1, wherein the radius of the prosthesis is expandable.
3. The prosthesis of claim 1, wherein the longitudinal axes of the struts are parallel to the
longitudinal axis of the prosthesis.
- 15 4. The prosthesis of claim 1, wherein the struts connect to the sinuate annular sections at
curve peaks of the sinuate annular sections.
5. A tubular prosthesis for the treatment of vulnerable plaque, comprising:
two sinuate annular end sections at opposite ends of the prosthesis; and
20 a center section comprising or consisting essentially of a plurality of struts having
parallel longitudinal axes with each other,
wherein the struts connect the opposite end sections.
6. The prosthesis of claim 5, wherein at least one of the end sections consists essentially of a
25 single sinuate form.
- 7.. The prosthesis of claim 5, wherein the struts connect to the end sections at peaks of the
sinuate form.
- 30 8. The prosthesis of claim 5, wherein the longitudinal axes of the struts are parallel to the
longitudinal axis of the tubular shape of the prosthesis.
9. The prosthesis of claim 5, wherein the prosthesis is at least partially metallic.

10. The prosthesis of claim 5, wherein the prosthesis is at least partially polymeric.
11. The prosthesis of claim 5, wherein the prosthesis is at least partially balloon expandable.
- 5 12. The prosthesis of claim 5, wherein the prosthesis is balloon expandable to a deployed radius by 3 ATM or less pressure.
13. The prosthesis of claim 5, wherein the prosthesis is at least partially self-expanding.
- 10 14. A method for treating vulnerable plaque in a patient in need thereof, comprising the steps of:
 deploying a prosthesis according to claim 1 at a site of a vulnerable plaque in blood vessel of a patient.
- 15 15. The method of 14, further comprising the step of delivering the prosthesis to the site using a delivery catheter.
16. The method of claim 14, further comprising the step of:
 prior to deploying the prosthesis, locating the site of vulnerable plaque.
- 20 17. The method of claim 14, wherein the prosthesis comprises:
 two sinuate annular end sections at opposite ends of the prosthesis; and
 a center section comprising or consisting essentially of a plurality of struts having parallel longitudinal axes with each other,
25 wherein the struts connect the opposite end sections to each other.
18. The method of claim 17, wherein:
 each end of the prosthesis consists essentially of a single sinuate annular section; and
 the center section consists essentially of struts having longitudinal axes parallel with
30 each other.
19. The method of claim 18, wherein the longitudinal axes of the struts are parallel to the longitudinal axis of the prosthesis.

20. The method of claim 14, wherein the prosthesis further comprises a cover that covers at least part of the plurality of struts.

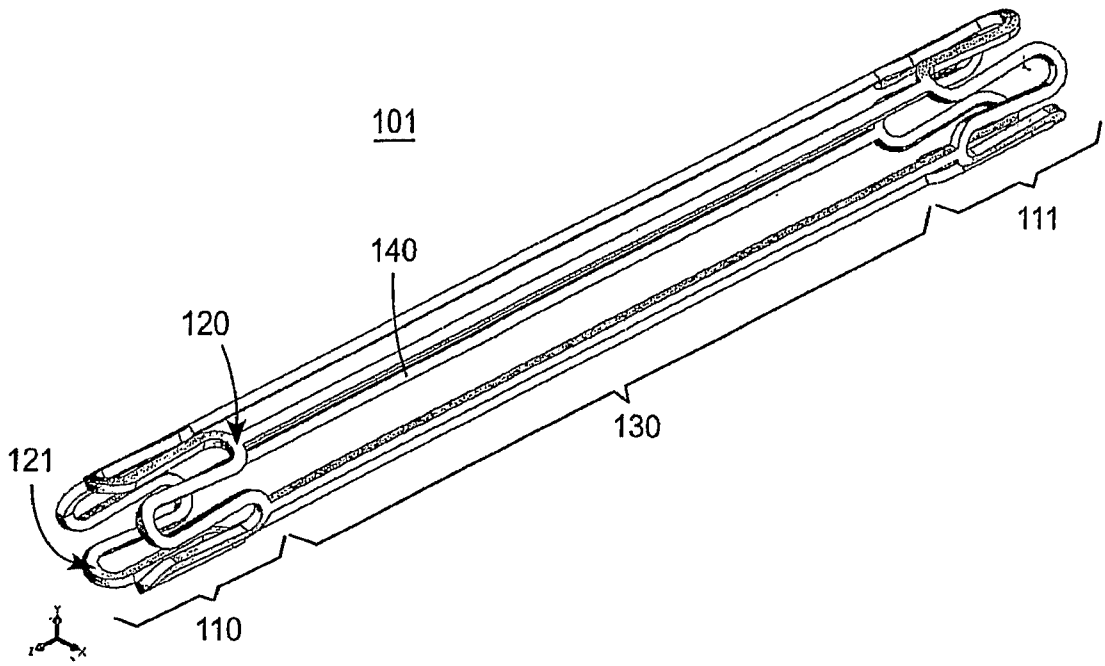

FIG. 1

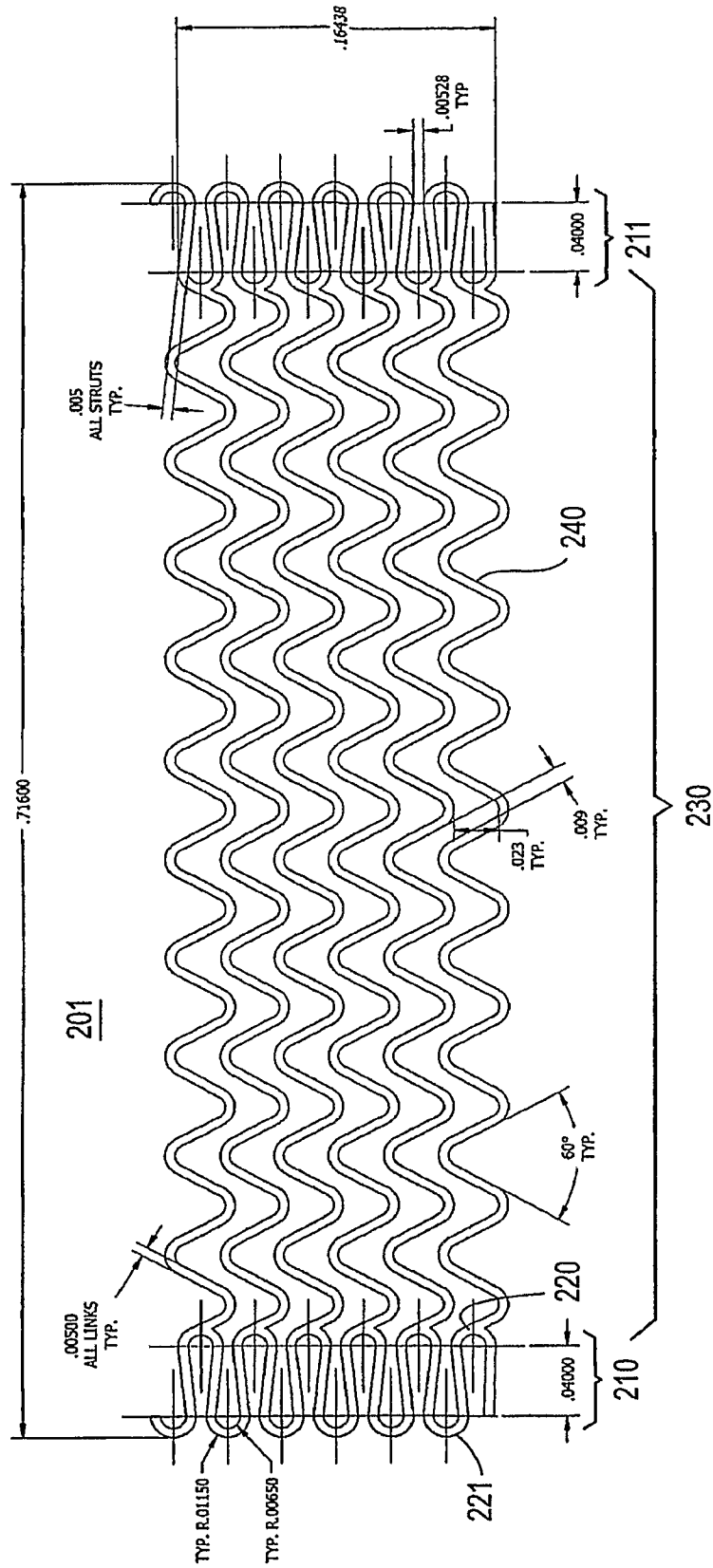

FIG. 2

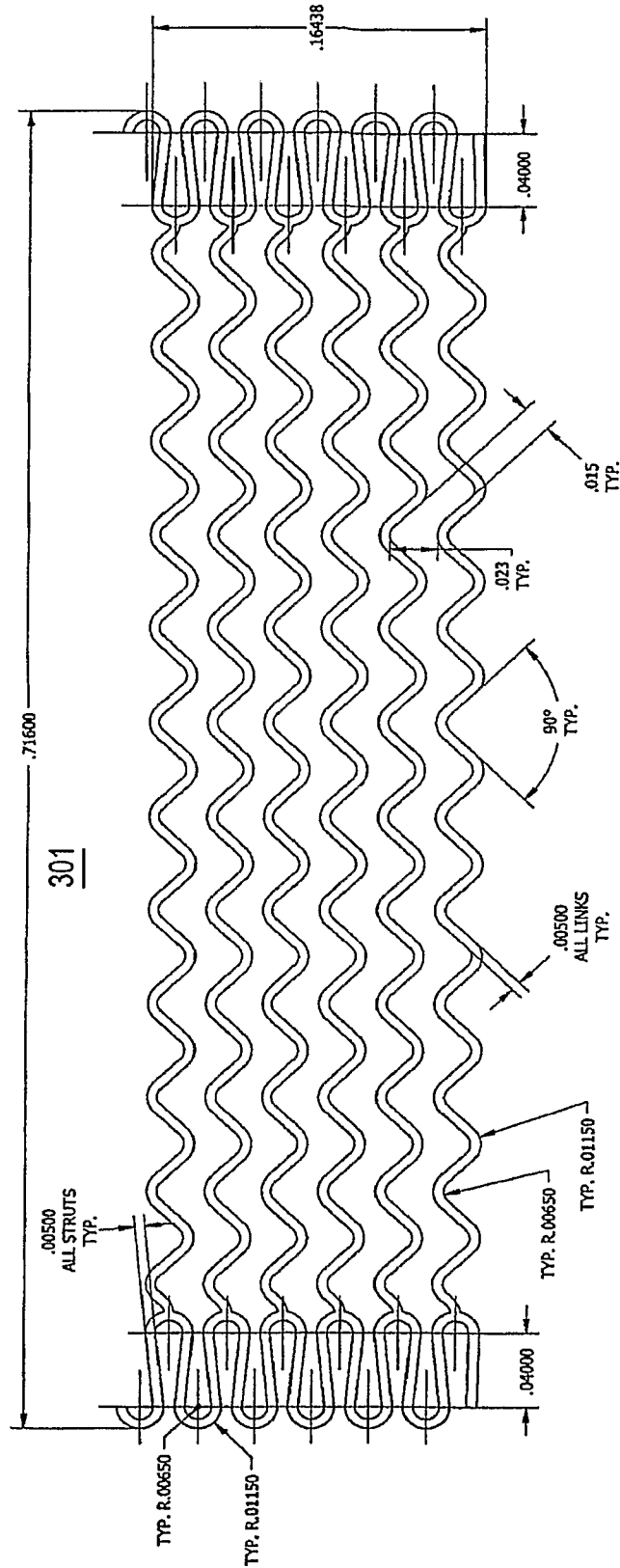

FIG. 3

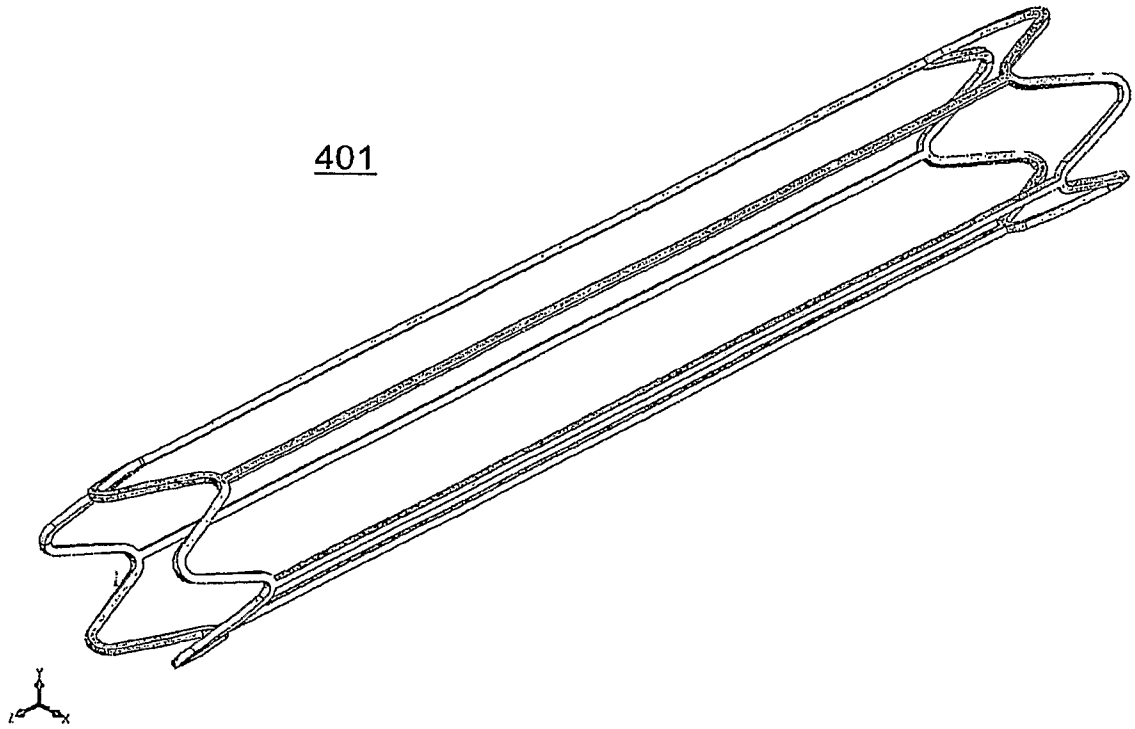

FIG. 4

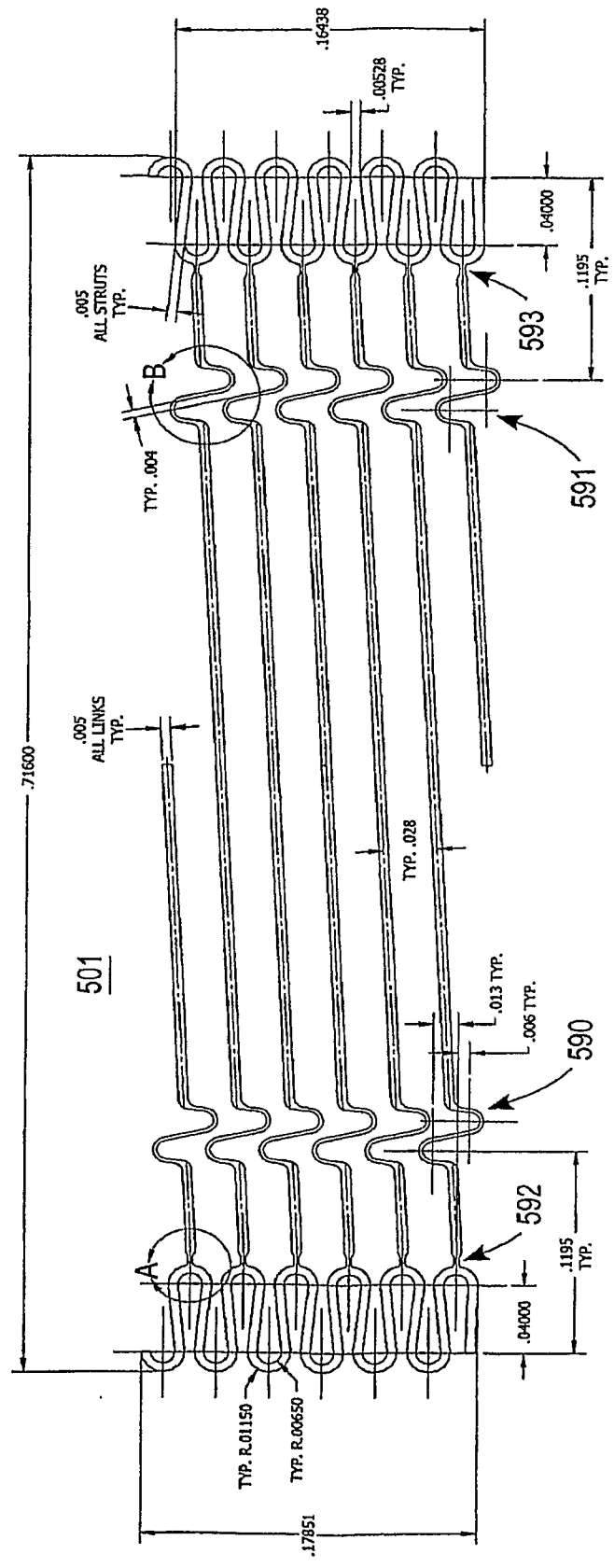
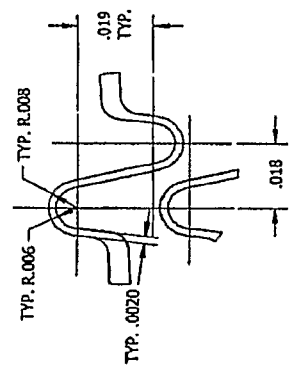
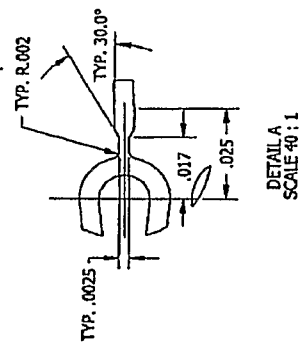

FIG. 5