

(19)  
(12)

(KR)  
(Y1)

(51) 。 Int. Cl.7  
A01K 67/033  
A01K 67/00

(45)  
(11)  
(24)

2004 09 06  
20-0361010  
2004 08 26

(21) 20-2004-0017191  
(22) 2004 06 18

(73) ( ) 11-1

(72) 3 1003 601

(74)

:

(54)

(BOX)

;

,

;

;

가

;

가

;

;

,

,

,

.

1

,

,

,

,

,

1

2 1 .

3 1 .

4a 4b .

5 .

6 .

\* \*

10: , 20: ,

27:가 , 30: ,

31: , 41: ,

51: , 55: ,

90: , 120: ,

가

earthworm/Oligochaeta) ( ) 80~120%

가

(BOX)

; 가 가 ; ; ;

가 , 가 (BOX) , 가 가 ;

가 ; ; ; 가 ;

; ; '스' ;

가 (BOX) ; ; ;

1 2

0) (30) (20) 가 (90)가 (90) (90) (90) (30) (40) (50) (40) (2) (5) (60)

3 (21) 가 (90) 가 (91)가 (94)가 (90)가 (90) (90) (90) (90) (90) (90) (31) (32a) (91) (90) (90) (91) (91) (93) (93) (90) (90) (120) (120) (120) (110) (90) (90) (120) (90) (90) (90)

a) (20) 4a 4b (90) (20) (90) (30) (90) (90) (90) (20) (21) (21) (95b) (90) (90) (95) (23) 가 (27) (21) (21) (21) (25) (25) 가 (27)

(25)가 (23)가 (23) (23) (95b)  
 가 (21)가 (21) (90)

(95a) (4b) )

(30) (90) (32a) (31) ( )  
 31) (90) (91) (35) (31) (32c) (32a) (32a) (32c)  
 ) (32a) (32a) (32b) ( 5 ) (32a) (32a) '스'

(91) (91) (91) (32a) (91) 가

가 (90) 가 (41) ( )  
 40) (90)가 (50) (51) (51) (51)

(50) ( ) (55) (51) (51) (51)  
 ) 가 (23) (53) (51) (53) (90) (51) ( )  
 (53)가 (53) (51) (53) (55) (6) )

(50) (60) (90) (60) (120)  
 (20) (30), (40), (50) (60) (20)  
 (60) ( ) (20)  
 (35,95a,95b)

가

가 가

(57)

1.

(BOX)

(20);

(90);

(90)

(30) (20) 가 (90) (90) 가 (40); (30);  
(90) (90) 가 (50); (40) (50)  
(90) (60);

**2.**  
1 가 , (90) 가 (BOX)  
(94)가 (91)가 , (91)가  
(93) ,

**3.**  
1 (21); 가 (20) (21) (90) (95a) (23);  
(27) (95b) (21) (25);

**4.**  
1 2 , (30) (90) (91) (3  
2a) , (32a) (32b) (32c) (31)  
; (31) (35);

**5.**  
4 , (32a) 'ㄴ'

**6.**  
1 (50) 가 (BOX) (51); (51);  
(51) (53); (51)  
(53) (55);

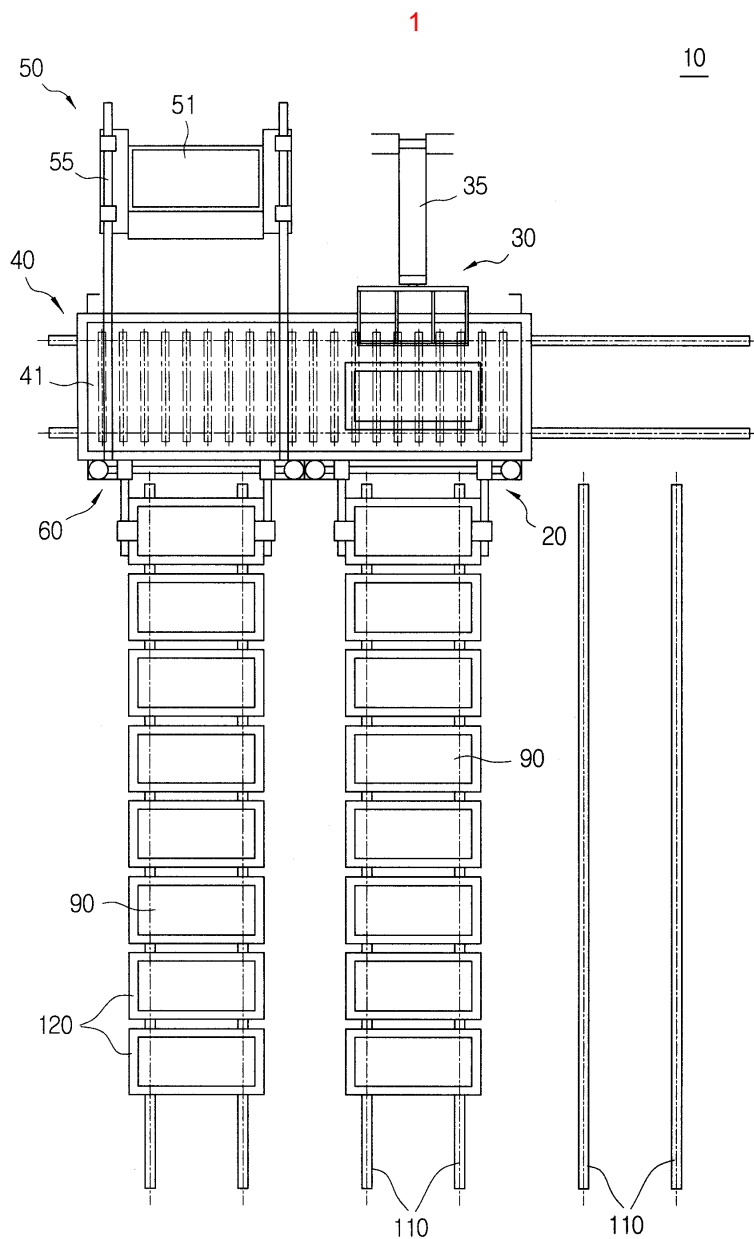

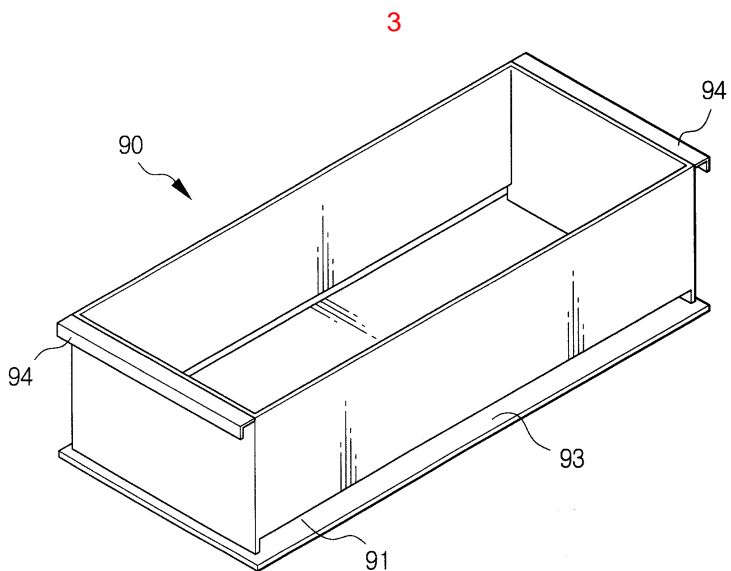
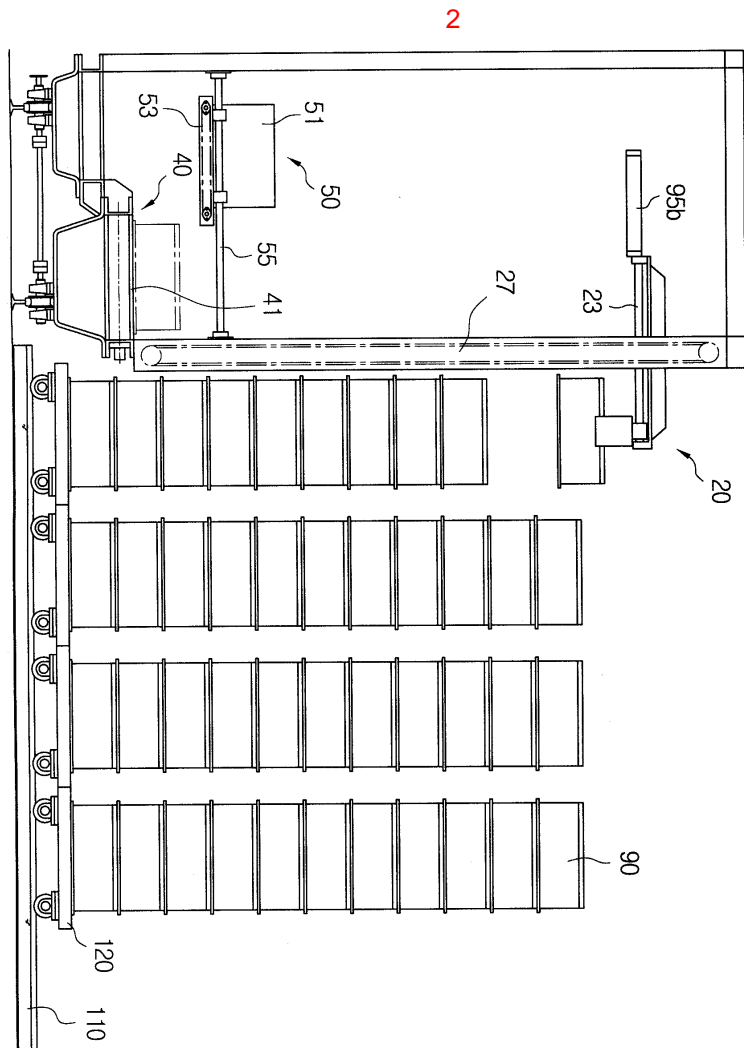

4a

10

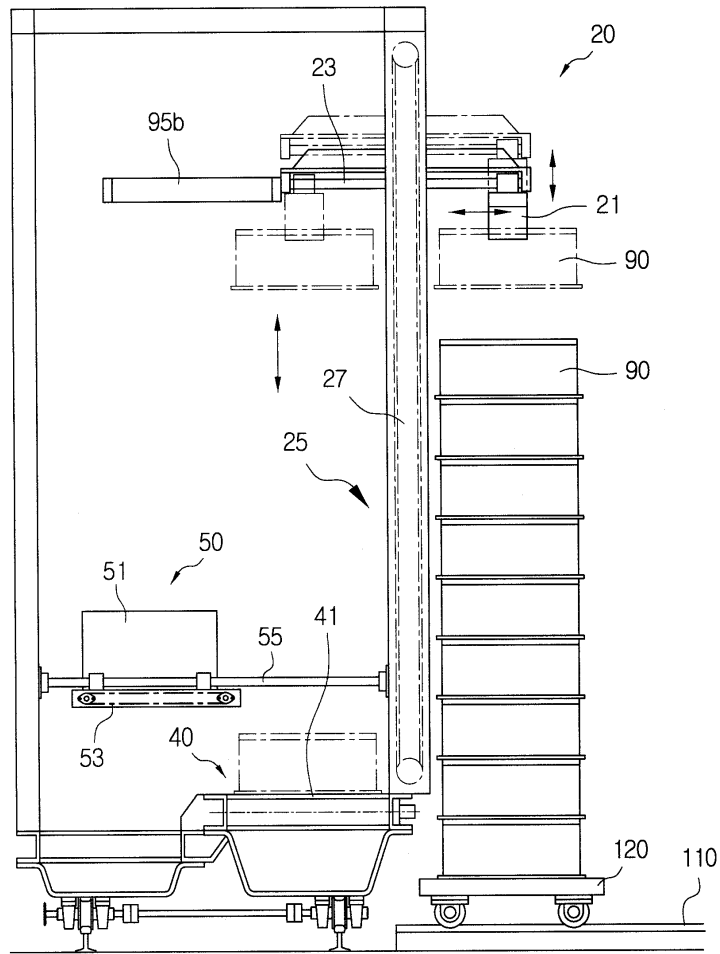



4b

20

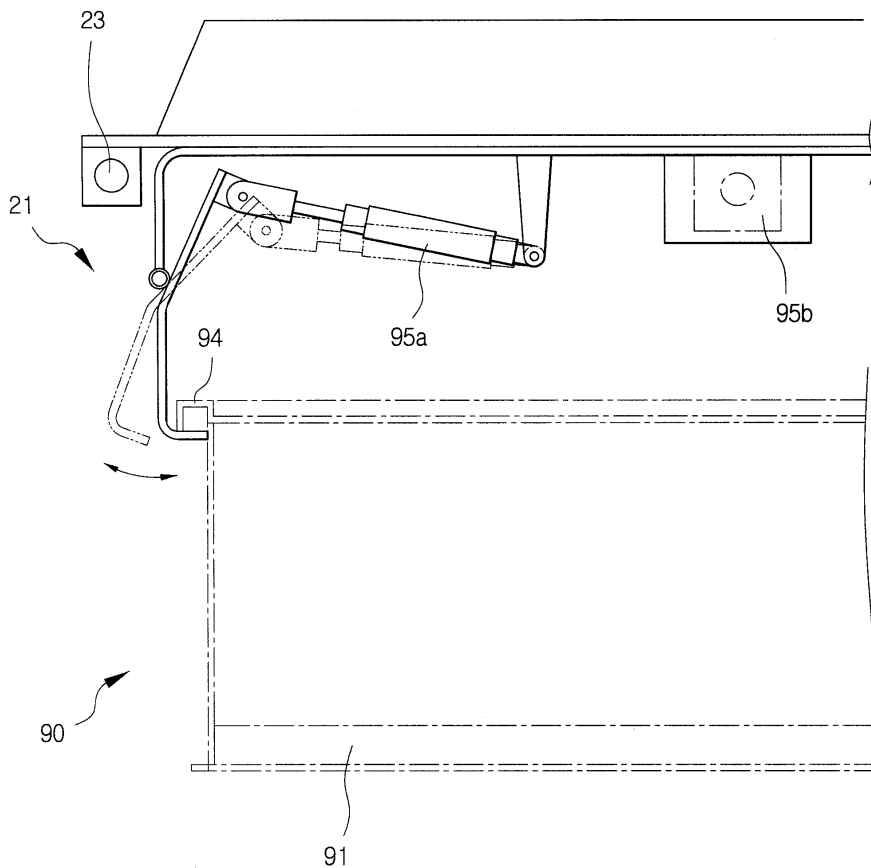

5

30

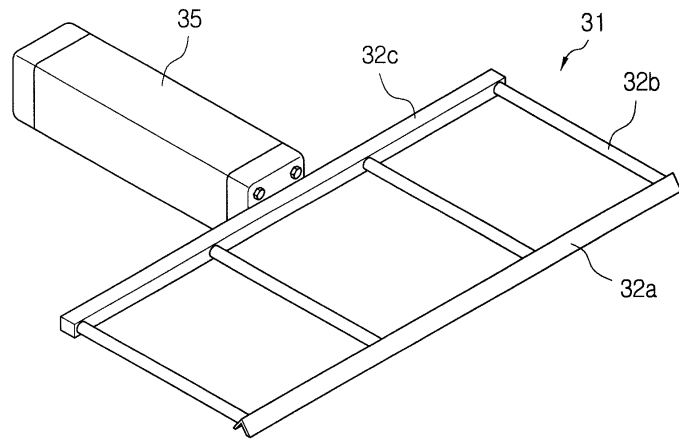

90

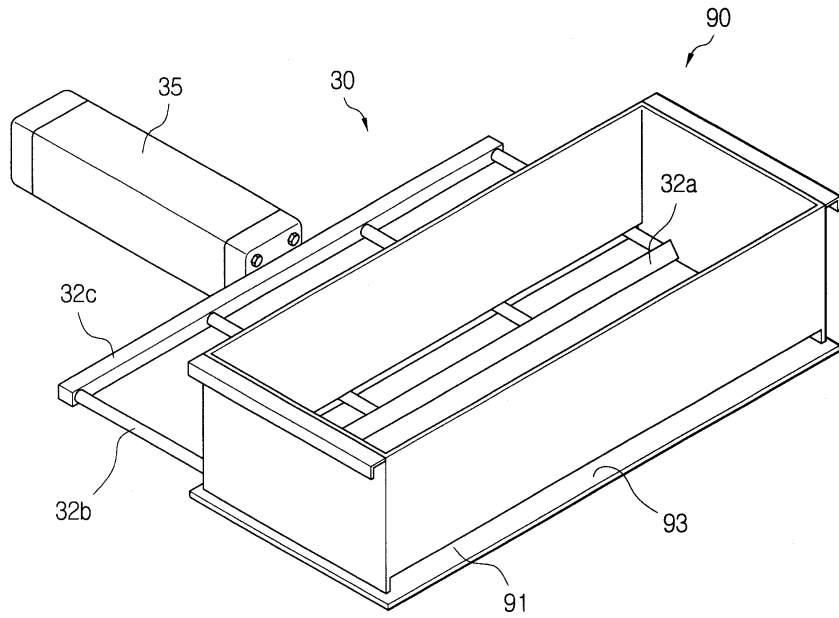

6

50

