



(22) Date de dépôt/Filing Date: 2003/11/06

(41) Mise à la disp. pub./Open to Public Insp.: 2005/05/06

(51) Cl.Int.⁷/Int.Cl.⁷ E04F 11/18, E04H 17/14

(71) Demandeur/Applicant:
WALKER, SIMON, CA

(72) Inventeur/Inventor:
WALKER, SIMON, CA

(54) Titre : BARRE D'ESPACEMENT ORNEMENTALE POUR LES LATTES VERTICALES D'UN SYSTEME DE RAMPES
(54) Title: ORNAMENTAL PICKET SPACER FOR A RAILING SYSTEM

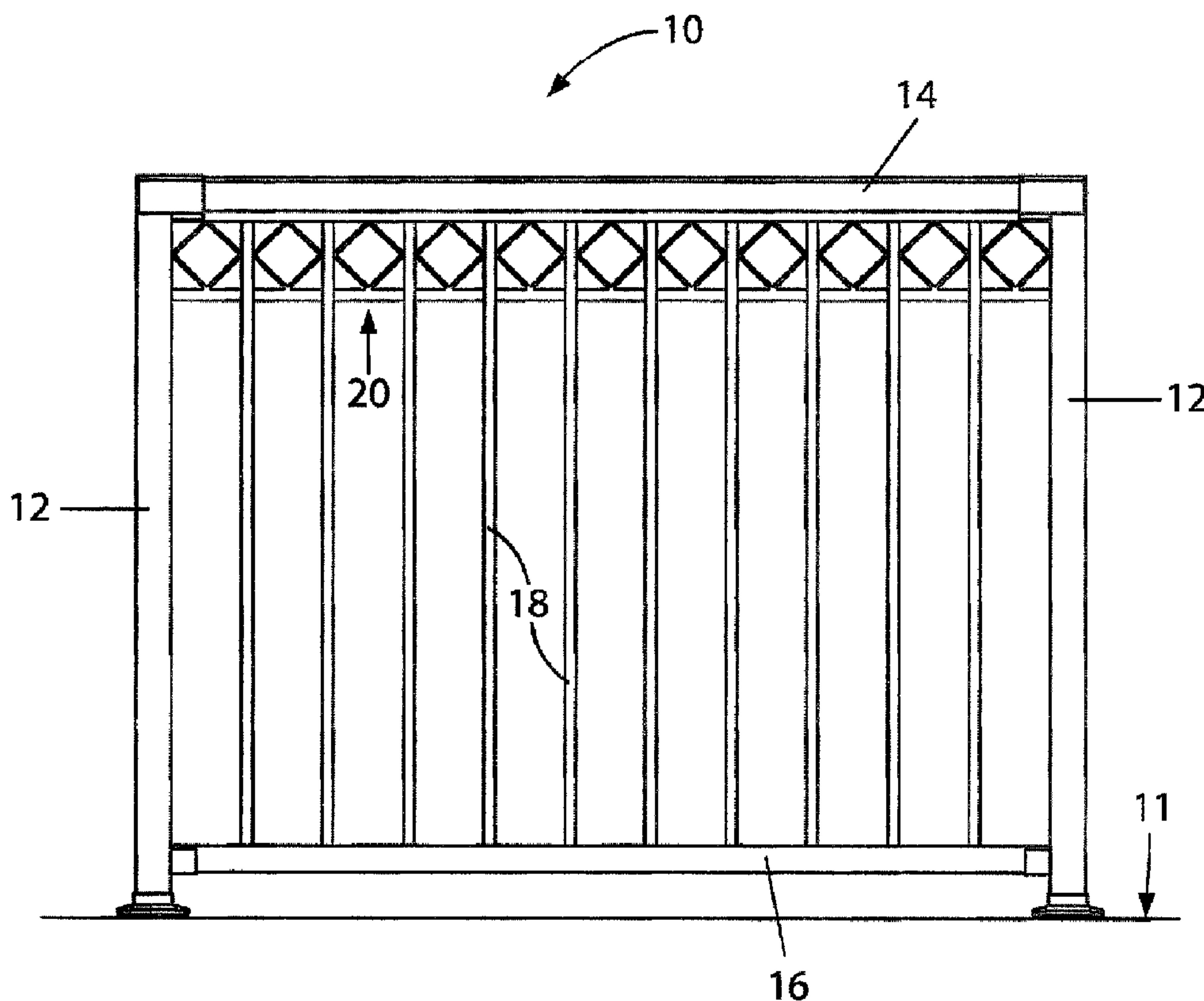

(57) Abrégé/Abstract:

An ornamental picket spacer for a railing system. The spacer may include an elongated spacer member having generally parallel sides and a wall extending therebetween and an ornamental member connected to the wall. The generally parallel sides of the elongated spacer member may include wings for insertion into the railing system. The ornamental member may be a diamond or a circle or any other suitable shape.

ABSTRACT

An ornamental picket spacer for a railing system. The spacer may include an elongated spacer member having generally parallel sides and a wall extending therebetween and an ornamental member connected to the wall. The generally parallel sides of the elongated spacer member may include wings for insertion into the railing system. The ornamental member may be a diamond or a circle or any other suitable shape.

TITLE OF THE INVENTION

ORNAMENTAL PICKET SPACER FOR A RAILING SYSTEM

5

FIELD OF THE INVENTION

The invention relates to the field of railings and in particular to an ornamental picket spacer for a railing system.

10

BACKGROUND OF THE INVENTION

Railing systems for any number of outdoor applications are well known. For example, residential decks, pool decks, playgrounds, etc., all utilize any number of conventional railing systems. Such railing systems are typically made of pressure treated lumber or aluminum particularly suited for outdoor use.

Generally, in order to add an ornamental shape to the railing system, typical railing systems require professionals, for example, welders, to attach the ornamental shape to the railing systems. These systems are undesirable, particularly in the residential railing industry where homeowners frequently install or build their own railing systems.

Accordingly, a need exists for providing a user with an improved system of adding an ornamental shape to a railing system and which overcomes the deficiencies noted above.

SUMMARY OF THE INVENTION

According to one aspect of the present invention there is provided an ornamental picket spacer for a railing system. The spacer may include an elongated spacer member having generally parallel sides and a wall extending therebetween. An
5 ornamental member may be connected to the wall.

The generally parallel sides of said elongated spacer member may include wings for insertion into the railing system.

10

The ornamental member may be a diamond or circle or any other suitable shape.

In accordance with another aspect of the present invention there is provided an ornamental picket spacer for a railing system. The spacer may include an
15 elongated spacer member having generally parallel sides and a wall extending therebetween. An ornamental member may be connected to the wall and an elongated cross member may be connected to the ornamental member. The elongated cross member may be disposed generally parallel to the spacer member and generally in the same plane as the elongated spacer member. The
20 elongated cross member may have first and second ends.

The generally parallel sides of the elongated spacer member may include wings for insertion into the railing system

25 The first and second ends of the elongated cross member may include connector means for connecting the elongated cross member to the pickets.

The connector means may include tines spaced apart for snugly engaging the pickets or connector walls extending generally perpendicular to the cross member.

30 The connector means may also include connector walls extending generally

perpendicular to the cross member and fasteners. The connector walls may each define a hole whereby the fasteners may be inserted through to the pickets.

The ornamental member may be a diamond or circle or any other suitable shape.

5

In accordance with yet another aspect of the present invention there is provided a kit for an ornamental picket spacer for a railing system. The kit may include an elongated spacer member having generally parallel sides and a wall extending therebetween and an ornamental member connectable to the wall. The kit may further include an elongated cross member connectable to the ornamental member and disposed generally parallel to the spacer member and generally in the same plane as the elongated spacer member. The elongated cross member may have first and second ends.

15 In accordance with yet another aspect of the present invention there is provided an ornamental picket spacer for a railing system. The spacer may include an elongated spacer member and an ornamental member connected to the elongated spacer member.

20 Other aspects of the invention will be appreciated by reference to the detailed description of the preferred embodiment and to the claims that follow.

BRIEF DESCRIPTION OF THE DRAWINGS

25

The preferred embodiment of the invention will be described by reference to the drawings thereof in which:

Fig. 1 is a plan view of a section of a picket and railing system illustrating installed ornamental picket spacers;

30

Fig. 2 is a perspective view of the ornamental picket spacer of Fig. 1;

Fig. 3 is a perspective view of an alternative embodiment of the ornamental picket spacer of Fig 2;

5

Fig. 4 is a plan view of a section of a picket and railing system illustrating an alternative embodiment of installed ornamental picket spacers;

Fig. 5 is a perspective view of the ornamental picket spacer of Fig. 4;

10

Fig. 6 is a perspective view of an alternative embodiment of the ornamental picket spacer of Fig 5;

Fig. 7 is a perspective view of another embodiment of the ornamental picket spacer of Fig 5;

15

Fig. 8 is a perspective view as viewed from below of yet another embodiment of the ornamental picket spacer of Fig. 5;

20 Fig 9. is a perspective view of yet another embodiment of the ornamental picket spacer of Fig 5; and

Fig. 10 is a perspective sectional view of a section of a picket and railing system illustrating the installation of an ornamental picket spacer.

25

DESCRIPTION OF THE PREFERRED EMBODIMENT
OF THE INVENTION

FIG. 1 shows a section of a picket and railing system generally indicated at 10
5 installed on a deck surface 11. The picket and railing system is generally formed
by a pair of post supports 12, a handrail 14, a base rail 16 and a plurality of pickets
18. A plurality of ornamental picket spacers 20 are used to space apart the
pickets 18 within the picket and railing system 10.

10 As illustrated in FIG. 2, the ornamental spacer 20 includes an elongated spacer
member 22 having generally parallel sides 24, 26 and a wall 28 extending
therebetween. An ornamental member 30 is connected to the wall 28. The
generally parallel sides 24, 26 may extend perpendicularly to the wall 28 or may
be curved. The generally parallel sides 24, 26 may include wings 32, 34,
15 respectively for insertion into the railing system and may be formed as an integral
part of the generally parallel sides. The wings 32, 34 may run the length of the
elongated spacer member 22 as illustrated. Alternatively, as those skilled in the
art will appreciate, the wings 32, 34 may be of any length along the elongated
spacer member 22.

20

In this embodiment, the ornamental member 30 is a diamond shape. In an
alternative embodiment, as illustrated in FIG. 3, the ornamental member 30 is
circular in shape. As those skilled in the art will appreciate, any number of suitable
shapes may be used as an ornamental member. For example, a star, a sun, or a
25 moon shape may be used as an ornamental member. Any desirable shape may
be used to add an ornamental feature to the railing system. The ornamental
member 30 may be welded to the wall 28, but is preferably an integral part of the
wall.

FIG. 4. shows a section of a picket and railing system generally indicated at 10 installed on a deck surface 11 with an alternative embodiment of an ornamental spacer 20. Again, the picket and railing system is generally formed by a pair of post supports 12, a handrail 14, a base rail 16 and a plurality of pickets 18. A plurality of ornamental spacers 20 are used to space apart the pickets 18 within the picket and railing system 10

As shown in FIG. 5 the ornamental spacer 20 includes an elongated spacer member 36 having generally parallel sides 38, 40 and a wall 42 extending therebetween. An ornamental member 44 is connected to the wall 42. An elongated cross member 46 is connected to the ornamental member and disposed generally parallel to the spacer member 36 and generally in the same plane as the elongated spacer member. The elongated cross member has first and second ends 48 and 50. The elongated cross member may have a pair of faces 49 which provides visual appeal to the cross member extending across the first and second ends 48 and 50 as shown in Fig. 4.

The generally parallel sides 38, 40 may include wings 52, 54, respectively for insertion into the railing system and may be formed as an integral part of the generally parallel sides. The wings 52, 54 may run the length of the elongated spacer member 36 as illustrated. Alternatively, as those skilled in the art will appreciate, the wings 52, 54 may be of any length along the elongated spacer member 36.

In this embodiment, the ornamental member 44 is a diamond shape. In an alternative embodiment, as illustrated in FIG. 6, the ornamental member 44 is circular in shape. Again, as those skilled in the art will appreciate, any number of suitable shapes may be used as an ornamental member. The ornamental member 44 may be welded to the wall 42, but is preferably an integral part of the wall.

Referring to FIGS. 4 and 5, the elongated cross member 46 may be of any length. Preferably, the elongated cross member 46 is of a length so that the first and second ends 48 and 50 abut pickets 18 on either side of the ornamental spacer 20 as illustrated in FIG. 4. This creates a visually clean look as it provides the illusion that a cross member runs the entire length of the picket and railing system section 10.

The first and second ends 48 and 50 may include connector means for connecting the elongated cross member 46 to the pickets. The connector means may simply include connector walls 56 extending generally perpendicular to the cross member 46. Alternatively, as illustrated in FIG. 7, the connector means may include tines 58 spaced apart for snugly engaging the pickets 18. The tines 58 may be of any sufficient length and may be welded to the first and second ends 48 and 50, but is preferably an integral part of the elongated cross member 46.

As illustrated in FIG. 8 the connector means may include connector walls 56 extending generally perpendicular to the cross member 46 and fasteners 59, for example, screws. In this embodiment, the connector walls 56 may each define a hole 60 whereby the fasteners 59 may be inserted through to the pickets 18.

FIG. 9 illustrates an alternative embodiment of the ornamental spacer 20. The ornamental spacer 20 may simply include an elongated spacer member 62 and an ornamental member 64 connected to the elongated spacer member.

As those skilled in the art will appreciate the features listed in each embodiment of the ornamental spacer 20 may be assembled together in a number of ways, including welding. Preferably, to provide a smooth clean look, the features of the ornamental spacer 20 are formed as one integral unit either through die casts or other similar processes.

OPERATION

Referring to FIG. 10, once the pair of post supports 12, handrail 14 and base rail 16 are installed on the deck surface 11 using conventional techniques, the pickets 18 may be spaced apart with the ornamental spacers 20.

5

The ornamental spacer 20 may simply attach to the underside of the handrail 14 in any number of ways known to those skilled in the art. For instance, a bonding agent may be applied to the elongated member 62 of the ornamental spacer 20 illustrated in FIG. 9. The elongated member 62 may then be bonded to the
10 underside of the handrail 14. Alternatively, depending upon whether the underside of the handrail 14 is shaped to receive the ornamental spacer 20, the ornamental spacer may simply slide into, or snap onto, the underside of the handrail 14. For example, as illustrated in FIG. 10, the ornamental spacer 20 may be slidably inserted along line 70 into the handrail 14.

15

Once the ornamental spacer 20 is fitted to the underside of the handrail 14, the spacer may be attached to the pickets 18 by way of tines 58 or alternative connector means. For example, a bonding agent may be applied to the connector walls 56. The connector walls 56 may then be pressed against the pickets 18 to
20 form a bond. Alternatively, fasteners 59, such as screws, may be used to fasten the connector walls 56 to the pickets 18.

CLAIMS

What is claimed is:

- 5 1. An ornamental picket spacer for a railing system, the spacer comprising:
- an elongated spacer member having generally parallel sides and a wall extending therebetween; and
- 10 an ornamental member connected to said wall.
2. The ornamental spacer of claim 1 wherein said generally parallel sides of said elongated spacer member comprise wings for insertion into the railing system.
- 15 3. The ornamental spacer of claim 1 wherein said ornamental member is a diamond.
4. The ornamental spacer of claim 1 wherein said ornamental member is a
- 20 circle.
5. An ornamental picket spacer for a railing system, the spacer comprising:
- an elongated spacer member having generally parallel sides and a wall extending therebetween;
- 25 an ornamental member connected to said wall; and
- an elongated cross member connected to said ornamental member and disposed generally parallel to said spacer member and generally
- 30

in the same plane as the elongated spacer member, said elongated cross member having first and second ends.

- 5
6. The ornamental spacer of claim 5 wherein said generally parallel sides of said elongated spacer member comprise wings for insertion into the railing system
- 10
7. The ornamental spacer of claim 5 wherein said first and second ends of said elongated cross member comprises connector means for connecting said elongated cross member to the pickets
- 15
8. The ornamental spacer of claim 7 wherein said connector means comprises tines spaced apart for snugly engaging the pickets.
- 20
9. The ornamental spacer of claim 7 wherein said connector means comprises connector walls extending generally perpendicular to said cross member
- 25
10. The ornamental spacer of claim 7 wherein said connector means comprises connector walls extending generally perpendicular to said cross member and fasteners, said connector walls each defining a hole whereby said fasteners may be inserted through to the pickets.
- 30
11. The ornamental spacer of claim 5 wherein said ornamental member is a diamond.
12. The ornamental spacer of claim 5 wherein said ornamental member is a circle.
13. A kit for an ornamental picket spacer for a railing system, the kit comprising:

an elongated spacer member having generally parallel sides and a wall extending therebetween; and

an ornamental member connectable to said wall.

5

14. A kit for an ornamental picket spacer for a railing system, the kit comprising:

an elongated spacer member having generally parallel sides and a wall extending therebetween;

10

an ornamental member connectable to said wall; and

an elongated cross member connectable to said ornamental member and disposed generally parallel to said spacer member and generally in the same plane as the elongated spacer member, said elongated cross member having first and second ends.

15

15. An ornamental picket spacer for a railing system, the spacer comprising:

20

an elongated spacer member; and

an ornamental member connected to said elongated spacer member.

25

30

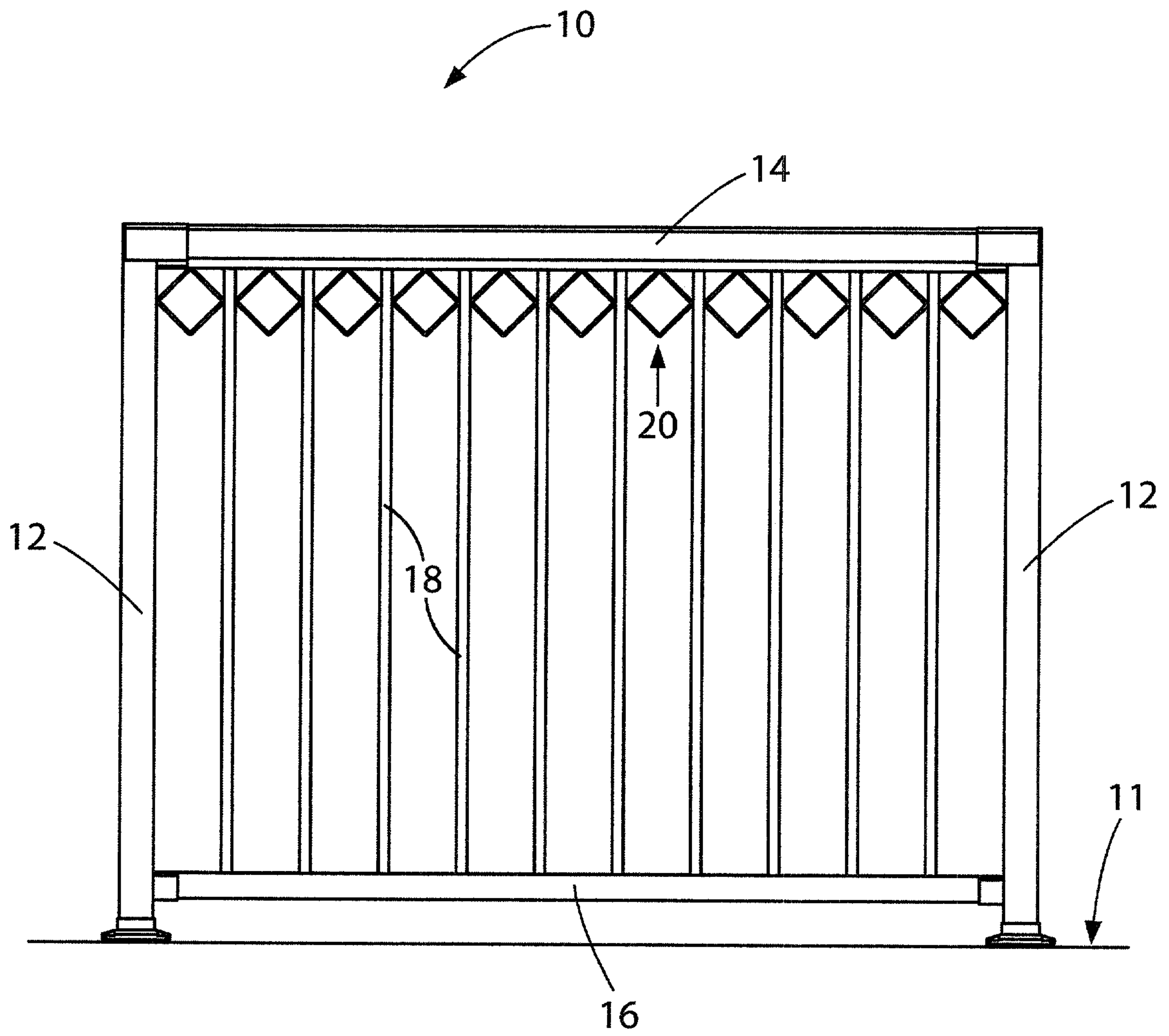

Fig. 1

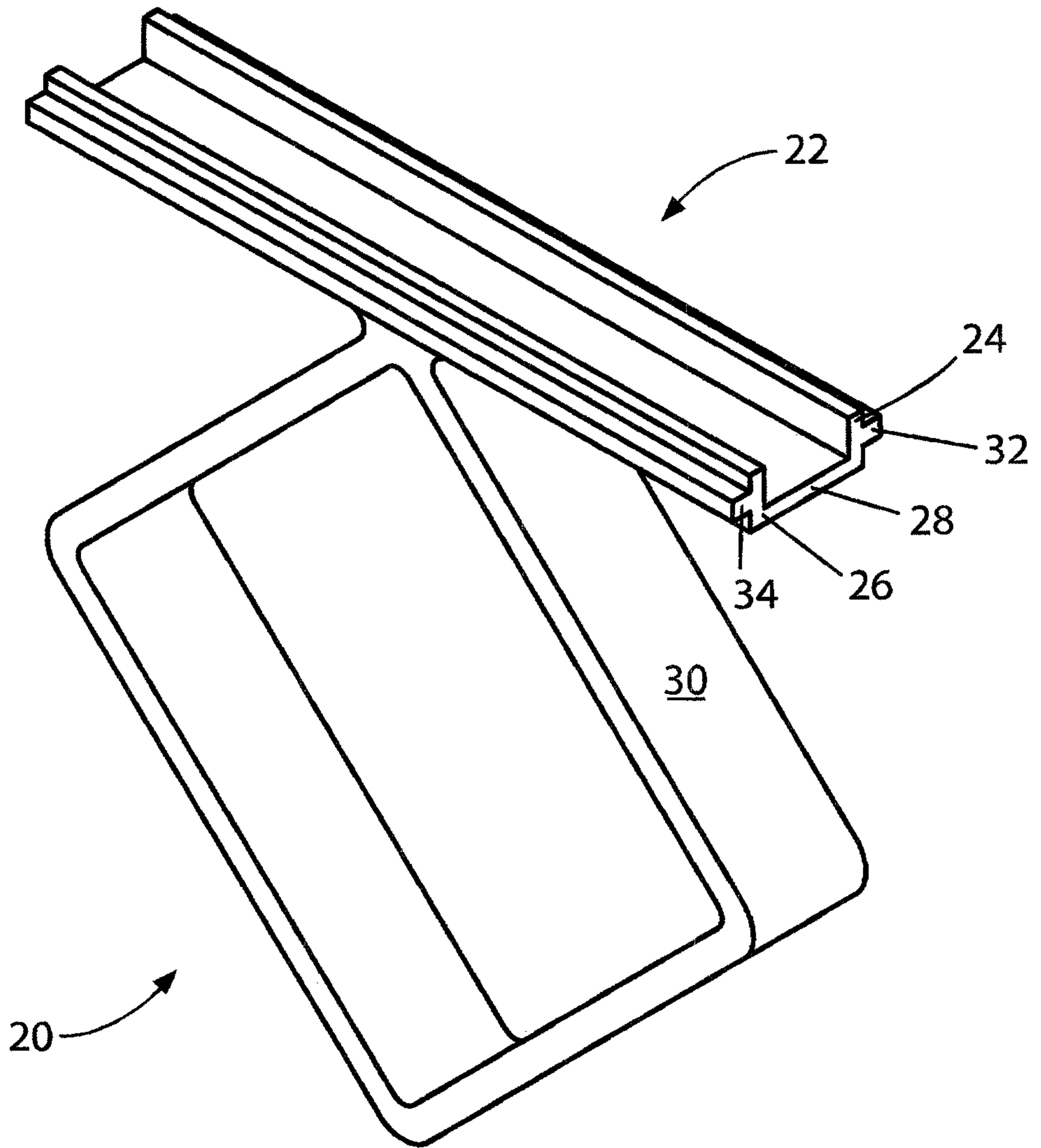

Fig. 2

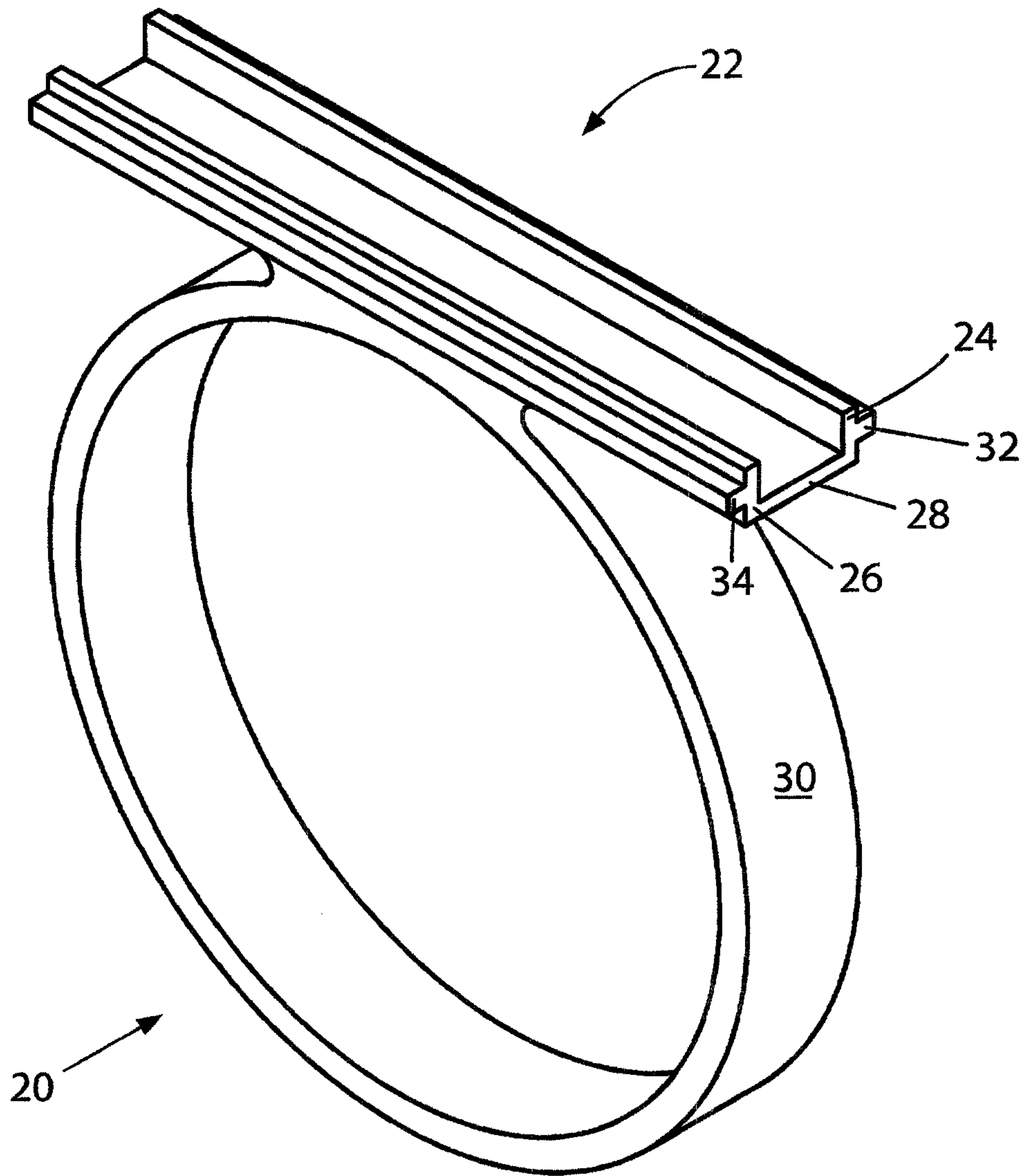

Fig. 3

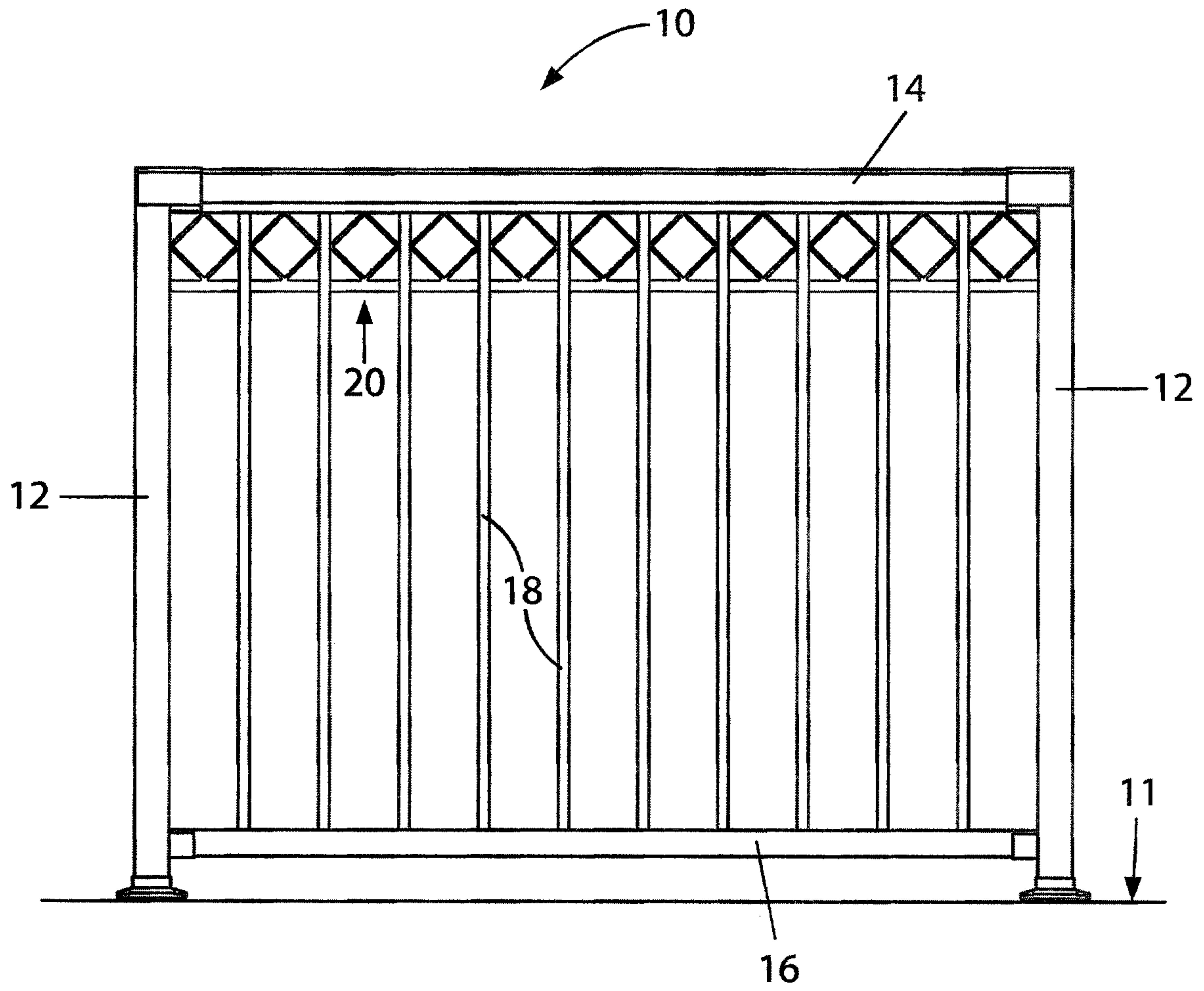

Fig. 4

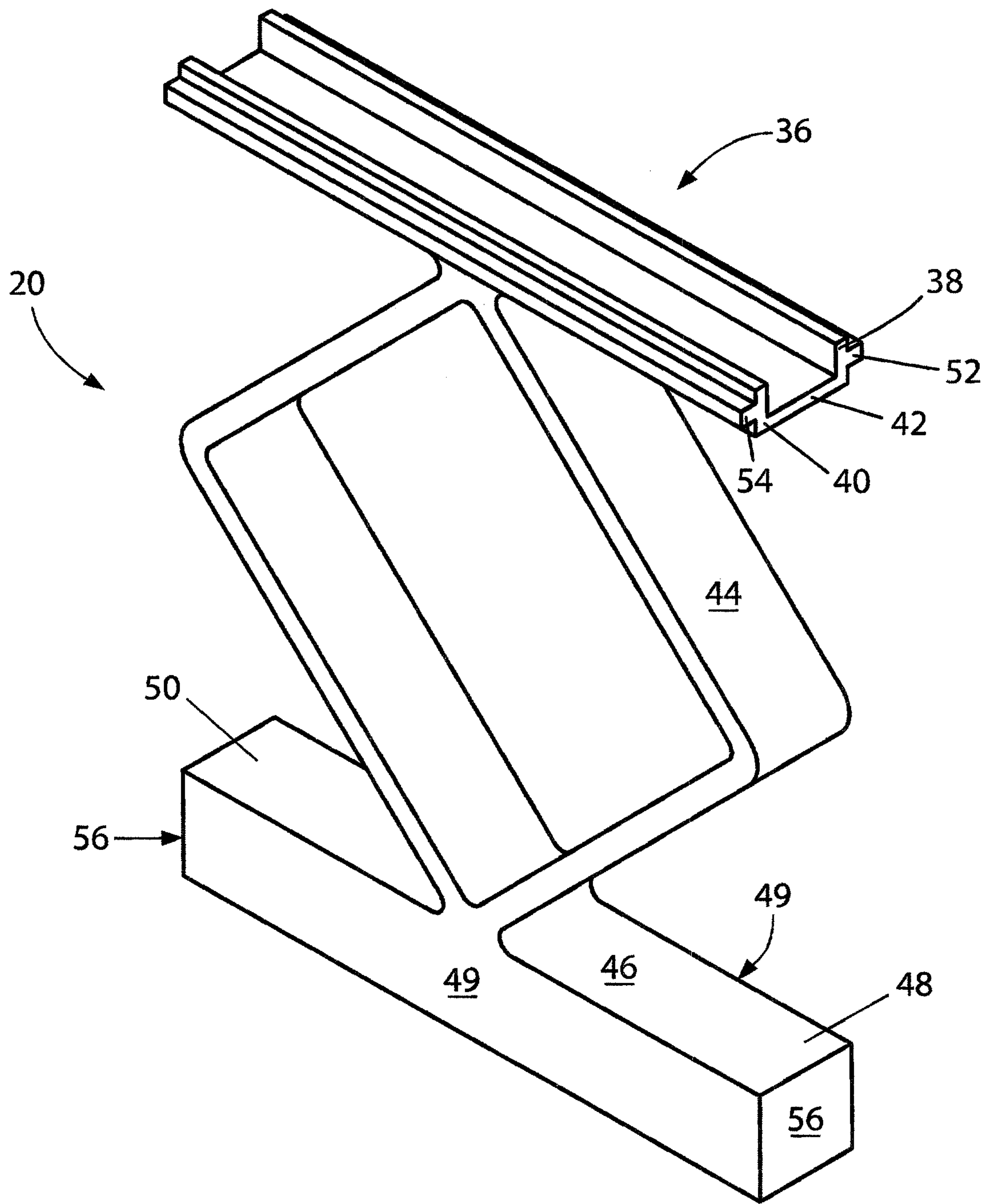

Fig. 5

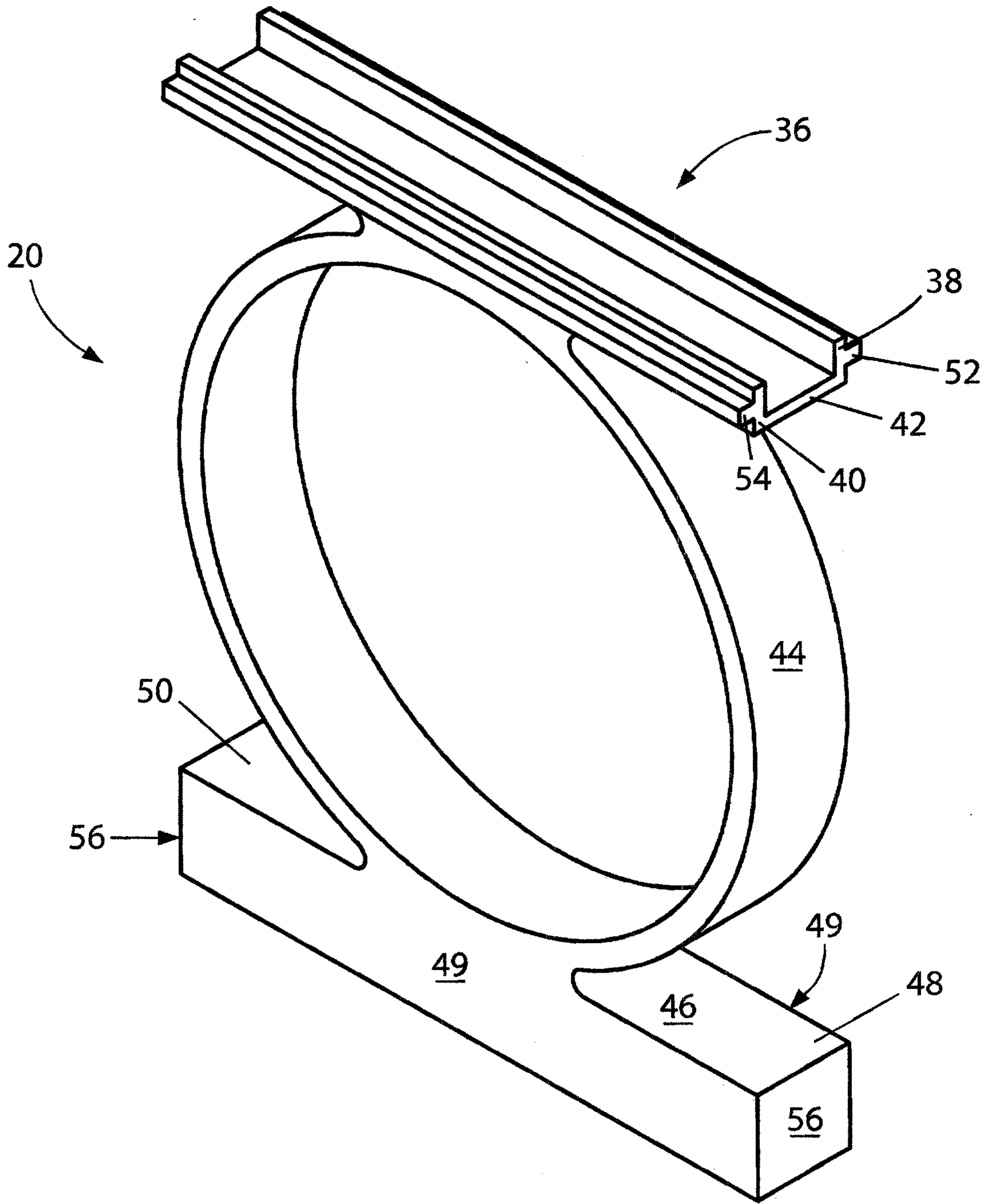

Fig. 6

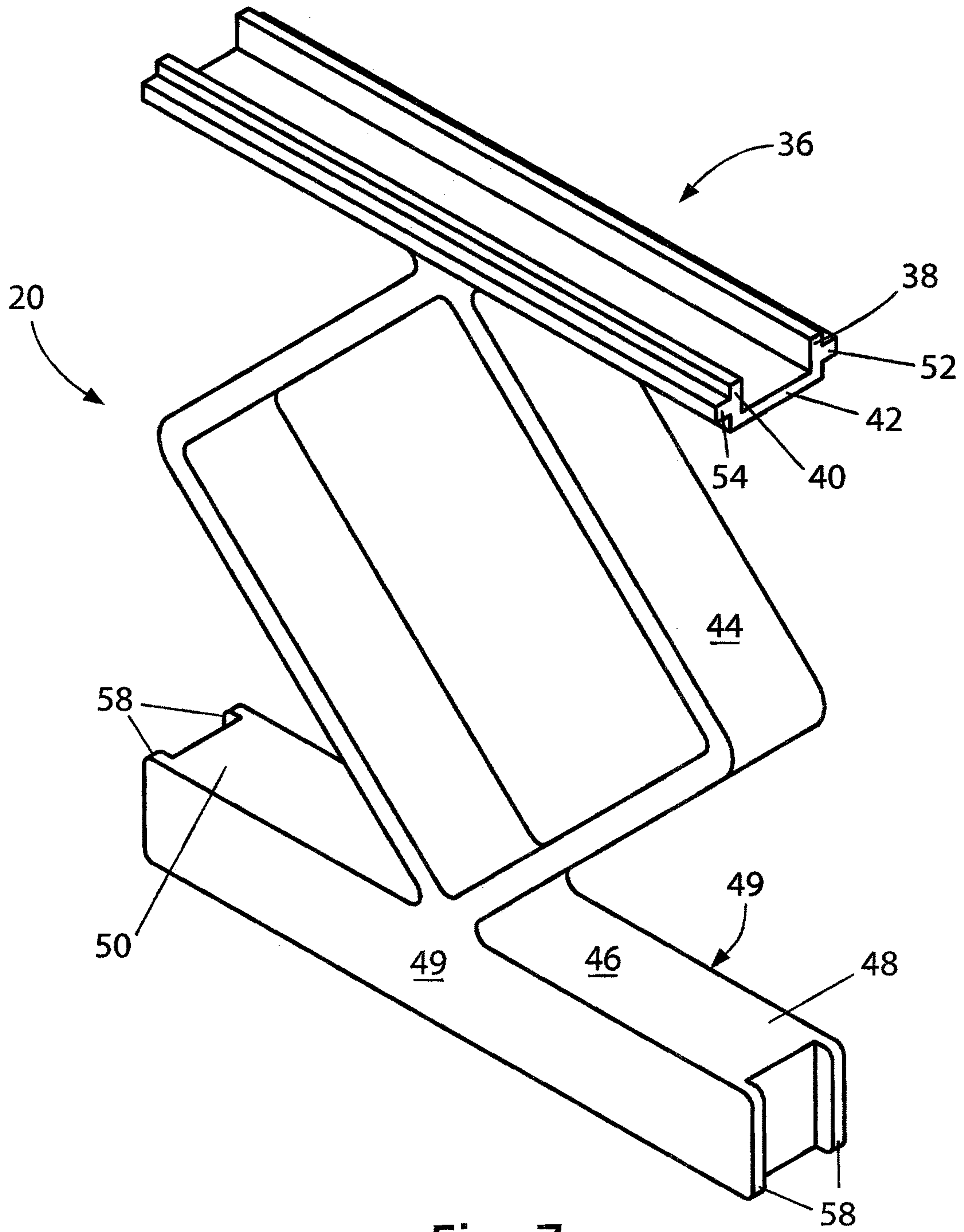

Fig. 7

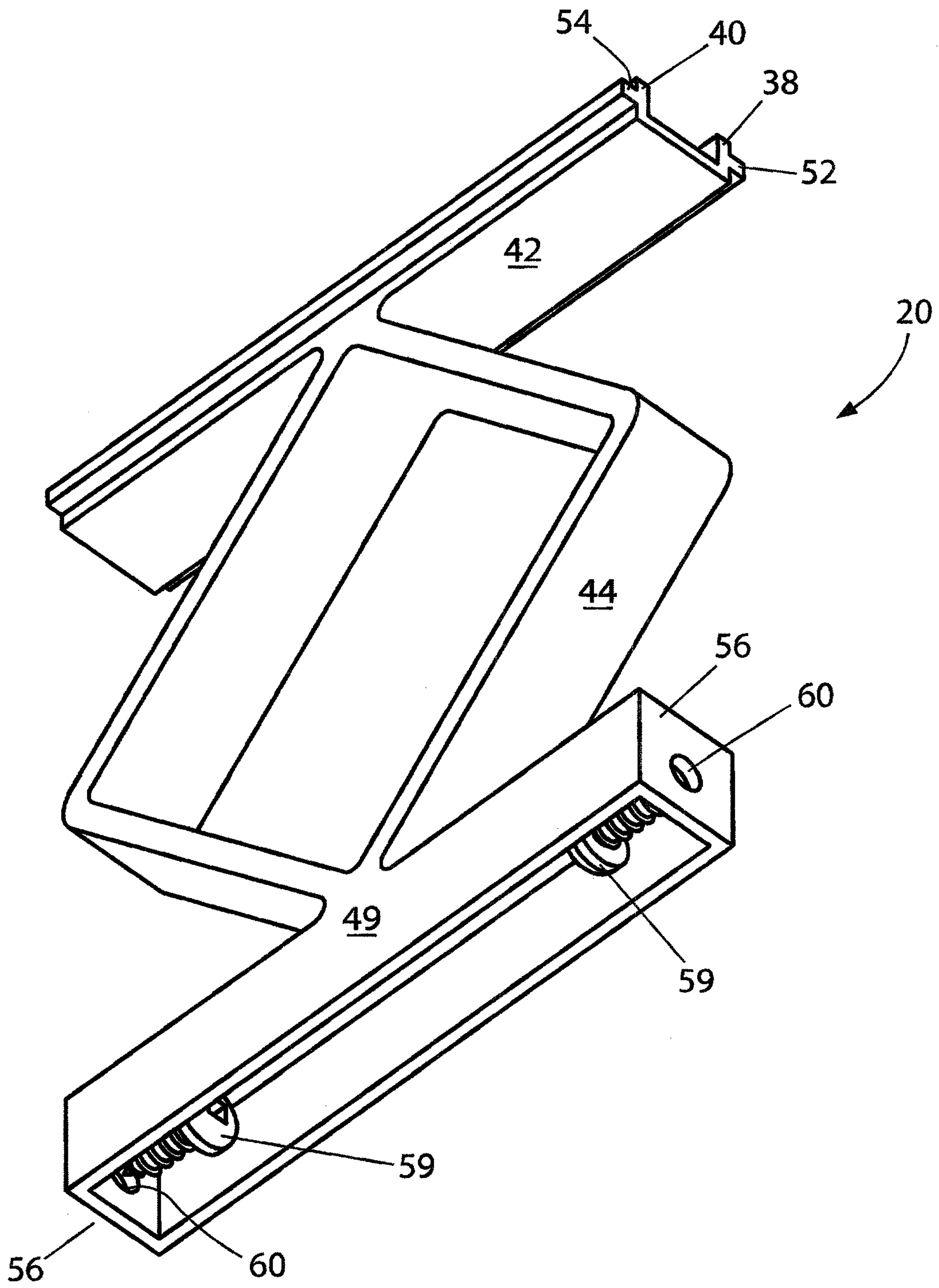

Fig. 8

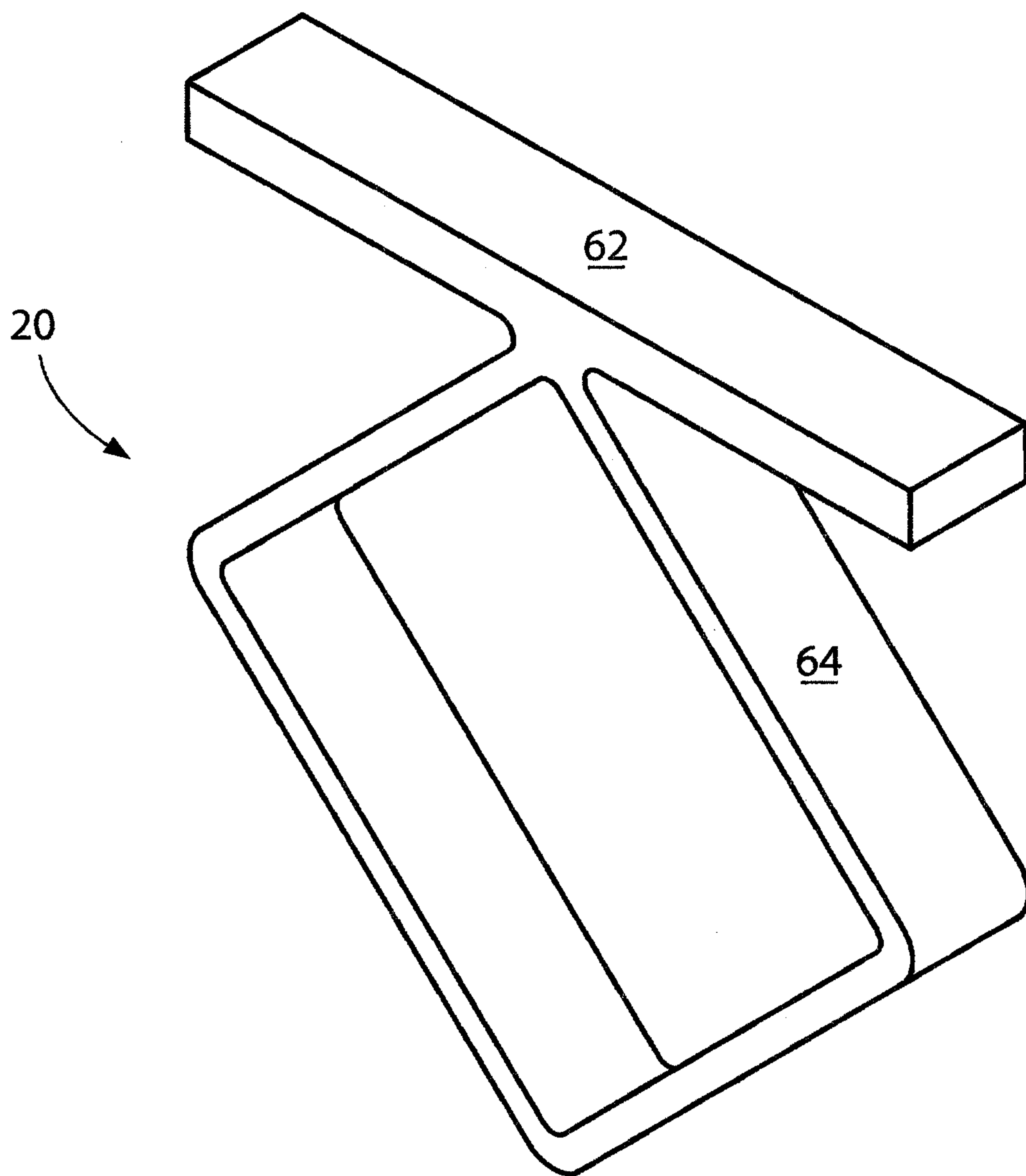

Fig. 9

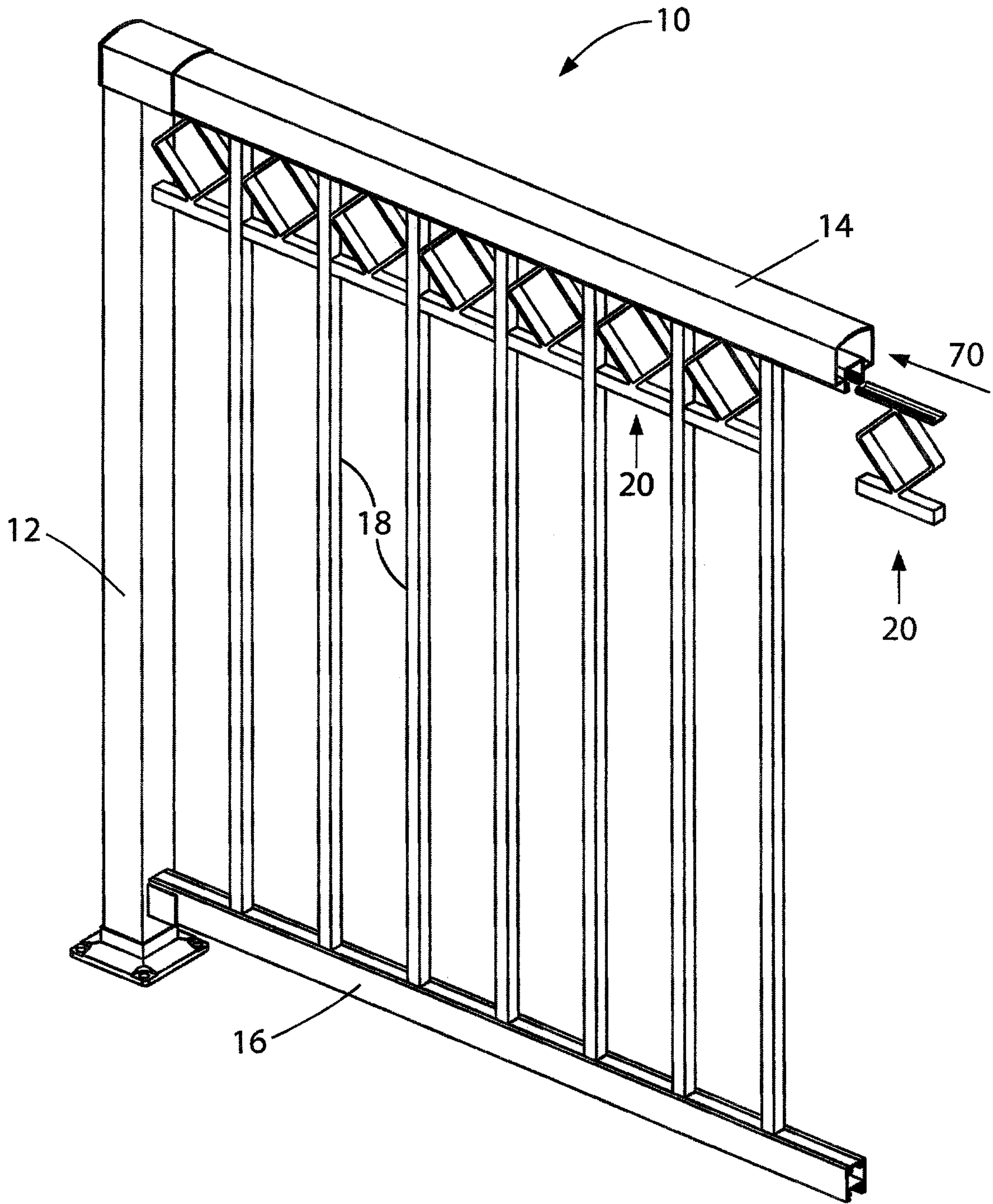

Fig. 10

