



(22) **Date de dépôt/Filing Date:** 2015/03/09

(41) **Mise à la disp. pub./Open to Public Insp.:** 2015/12/06

(45) **Date de délivrance/Issue Date:** 2017/03/07

(30) **Priorité/Priority:** 2014/06/06 (US14/298,105)

(51) **Cl.Int./Int.Cl. B64C 3/50** (2006.01),
B64C 9/34 (2006.01)

(72) **Inventeurs/Inventors:**
JAMISON, FLINT M., US;
AMOROSI, STEPHEN R., US;
KLEIN, MICHAEL K., US

(73) **Propriétaire/Owner:**
THE BOEING COMPANY, US

(74) **Agent:** SMART & BIGGAR

(54) **Titre : DISPOSITIF DE BORD DE FUITE DIVERGENT COULISSANT**

(54) **Title: SLIDABLE DIVERGENT TRAILING EDGE DEVICE**

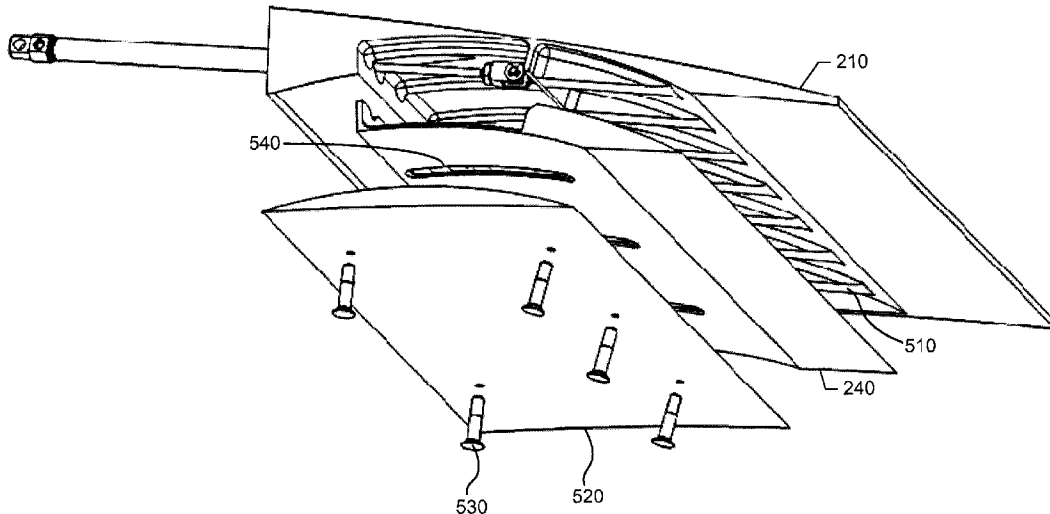

(57) **Abrégé/Abstract:**

An apparatus includes a wing and a divergent trailing edge panel. The wing includes: an upper surface and a lower surface opposite the upper surface; a trailing edge; a compartment defined between the upper surface and the lower surface; and an opening for the compartment defined in the lower surface and spaced apart from the trailing edge such that a portion of the lower surface is disposed between the opening and the trailing edge. The divergent trailing edge panel is slidably disposed within the compartment, and slideable between a stowed position in which the divergent trailing edge panel is disposed within the compartment, and a deployed position in which the divergent trailing edge panel extends through the opening and below the portion of the lower surface between the opening and the trailing edge, the divergent trailing edge panel increasing lift over drag of the wing when in the deployed position.

ABSTRACT

An apparatus includes a wing and a divergent trailing edge panel. The wing includes: an upper surface and a lower surface opposite the upper surface; a trailing edge; a compartment defined between the upper surface and the lower surface; and an opening for the compartment defined in the lower surface and spaced apart from the trailing edge such that a portion of the lower surface is disposed between the opening and the trailing edge. The divergent trailing edge panel is slidably disposed within the compartment, and slideable between a stowed position in which the divergent trailing edge panel is disposed within the compartment, and a deployed position in which the divergent trailing edge panel extends through the opening and below the portion of the lower surface between the opening and the trailing edge, the divergent trailing edge panel increasing lift over drag of the wing when in the deployed position.

SLIDABLE DIVERGENT TRAILING EDGE DEVICE

BACKGROUND

5 A Divergent Trailing Edge (DTE) device can increase lift over drag (L/D) of a wing. The DTE may be fixed to an aft lower surface of a wing. However, a fixed DTE creates a load distribution that can have a significant collateral impact of requiring a stronger, heavier wing.

10 A DTE may instead be hinged to an aft lower surface of a wing. A hinged DTE may be retracted to a stowed position, and it may be scheduled to extend during the less heavily loaded phases of flight, thus minimizing the collateral structural weight.

15 A hinged DTE may be extended and retracted by an actuator and drive linkage. The actuator and linkage carry air loads and, therefore, are sized accordingly. If the actuator fails during flight, free surface flutter of the hinged DTE can occur. If the actuator and linkage are too large to fit within the airfoil, they are covered by an external fairing, which adds complexity, weight, and drag.

SUMMARY

20 According to an embodiment herein, a wing comprises a trailing edge, and a divergent trailing edge device slideable along an aft surface of the trailing edge between a stowed position and a fully deployed position. The trailing edge device is located entirely within the trailing edge when stowed, and it increases lift over drag of the wing when deployed.

According to another embodiment herein, an aircraft comprises a wing including a trailing edge having a moveable flight control surface and a fixed surface.

The aircraft further comprises a plurality of divergent trailing edge devices integrated with the moveable flight control surface, and a plurality of actuators for independent control of the divergent trailing edge devices. Each divergent trailing edge device is slideable between a stowed position entirely within the moveable flight control surface and a deployed position at least partially under the moveable flight control surface.

According to another embodiment herein, a method performed during flight of an aircraft comprises sliding a divergent trailing edge device along a trailing edge of each aircraft wing to reduce lift over drag (L/D) of the wing; and thereafter stowing the divergent trailing edge device entirely within the trailing edge.

In accordance with another embodiment, there is provided an apparatus. The apparatus includes a wing. The wing includes: an upper surface and a lower surface opposite the upper surface; a trailing edge; a compartment defined between the upper surface and the lower surface; and an opening for the compartment defined in the lower surface, the opening spaced apart from the trailing edge such that a portion of the lower surface is disposed between the opening and the trailing edge. The apparatus further includes a divergent trailing edge panel slidably disposed within the compartment, the divergent trailing edge panel slideable between: a stowed position in which the divergent trailing edge panel is disposed within the compartment; and a deployed position in which the divergent trailing edge panel extends through the opening and below the portion of the lower surface between the opening and the trailing edge, the divergent trailing edge panel increasing lift over drag of the wing when in the deployed position.

In another embodiment, there is provided an aircraft. The aircraft includes a wing including a moveable flight control surface. The moveable flight control surface has: a trailing edge; a compartment defined between an upper surface of the moveable flight control surface and a lower surface of the moveable flight control

surface; and an opening for the compartment defined in the lower surface, the opening spaced apart from the trailing edge such that a portion of the lower surface is disposed between the opening and the trailing edge. The aircraft further includes a divergent trailing edge panel disposed within the compartment, the divergent trailing edge panel slideable between: a stowed position in which the divergent trailing edge panel is disposed within the compartment; and a deployed position in which the divergent trailing edge panel extends from the compartment and is disposed below the moveable flight control surface. The aircraft further includes an actuator to control the divergent trailing edge panel independently of the moveable flight control surface.

In another embodiment, there is provided a method. The method involves: sliding a divergent trailing edge panel through a compartment defined in an aircraft wing and through an opening in a lower surface of the wing to reduce lift over drag (L/D) of the wing, the compartment defined between an upper surface and the lower surface of the wing, the opening defined in the lower surface and spaced apart from a trailing edge of the wing such that a portion of the lower surface is disposed between the opening and the trailing edge.

These features and functions may be achieved independently in various embodiments or may be combined in other embodiments. Further details of the embodiments can be seen with reference to the following description and drawings.

BRIEF DESCRIPTION OF THE DRAWINGS

FIG. 1 is an illustration of an aircraft.

FIG. 2 is an illustration of a wing.

FIG. 3A is an illustration of a divergent trailing edge device in a fully deployed

position.

FIG. 3B is an illustration of a divergent trailing edge device in a stowed position.

FIG. 3C is an illustration taken along sectional lines 3C-3C in FIG. 3B.

5 FIG. 4 is an illustration of a wing and a divergent trailing edge device at a

trailing edge of the wing.

FIG. 5 is an illustration of a wing, a divergent trailing edge device, and a cover for a lower surface of the divergent trailing edge device.

FIG. 6 is an illustration of a wing, a divergent trailing edge device, and a cover
5 for an upper surface of the divergent trailing edge device.

FIG. 7 is an illustration of a divergent trailing edge device including a substantially straight stiffened panel.

FIGS. 8A and 8B are illustrations of a wing including a plurality of divergent trailing edge devices.

FIG. 9 is an illustration of a method of enhancing performance of an aircraft.
10

DETAILED DESCRIPTION

Reference is made to FIG. 1, which illustrates an aircraft **110** including a fuselage **120**, wings **130**, and empennage **140**. One or more propulsion units **150**
15 are coupled to the fuselage **120**, wings **130** or other portions of the aircraft **110**.

Reference is made to FIG. 2. Each wing **130** includes a leading edge and a trailing edge **210**. The trailing edge **210** may include fixed surfaces **220** and moveable flight control surfaces **230**. Examples of the moveable flight control surfaces **230** include, but are not limited to, ailerons, flaps, flaperons, and slats.

The wing **130** further includes at least one divergent trailing edge (DTE) device **240**. Each DTE device **240** is slideable along an aft surface of the trailing edge **210** between a stowed position and a fully deployed position. When stowed, the DTE device **240** is entirely within the trailing edge **210**. When deployed fully or
20

partially, the DTE device **240** extends beneath a lower surface of the trailing edge **210** to increase lift over drag of the wing **130**.

Chord length of the DTE device **240** may be between about 1% and 6% of chord length of the wing **130**. In some configurations, the DTE device **240** may have
5 a chord length between about four and six inches.

Each DTE device **240** may be mounted to either a fixed surface **220** of the trailing edge **210** or a moveable flight control surface **230** of the trailing edge **210**. In some wing configurations, multiple DTE devices **240** may be mounted to a fixed surface **220** and/or a moveable flight control surface **230**.

10 Reference is now made to FIGS. **3A** and **3B**, which illustrate an example of a wing **130** including a moveable flight control surface **230** and a DTE device **240** mounted to the moveable flight control surface **230**. The DTE device **240** includes a stiffened panel **310**. In some configurations, such as the configuration illustrated in FIGS **3A** and **3B**, the stiffened panel **310** is curved. In other configurations, the
15 stiffened panel may be straight (see, e.g., FIG. **7**).

The moveable flight control surface **230** also includes a cover **315** for the DTE device **240**. The cover **315** may also provide a sliding surface for the DTE device **240**.

An actuator assembly **320** may be utilized to slide the trailing edge device **240**
20 between the stowed and deployed positions. The actuator assembly **320** may control the DTE device **240** independently of the moveable flight control surface **230**. In some configurations, the actuator assembly **320** may include an actuator and linkage. In other configurations, the actuator assembly **320** may include an actuator alone. The actuator may be pneumatic, hydraulic, or electromechanical, and it may
25 be located in a wing box **330** of the wing **130**.

FIG. 3A shows the DTE device **240** in a fully deployed position. By way of example, FIG. 3A shows the DTE device **240** with a maximum divergence angle (α) of about **15** degrees.

The stiffened panel **310** may have a curvature whereby the divergence angle (α) of the DTE device **240** varies as the DTE device **240** is being deployed. For instance, the DTE device **240** has a maximum divergence angle (α) when fully deployed, and a smaller divergence angle (α) when partially deployed.

FIG. 3B shows the DTE device **240** in the stowed position. The DTE device **240** is located entirely inside the moveable flight control surface **230** and, therefore, does not affect L/D of the wing **130**.

The DTE device **240** may be stowed to avoid exposure to high loading. As a result, a wing **130** including the DTE device **240** may have lighter wing structures than a wing including a fixed divergent trailing edge device. The lighter structures, in turn, lead to weight and fuel savings. Yet the DTE device **240** may offer the same L/D advantage as a fixed divergent trailing edge device.

Because the DTE device **240** is slideable instead of hinged, air loads are mostly carried through the wing **130**. As a result, the DTE device **240** avoids issues inherent in hinged devices, such as issues with stiffness and torsional loads. The DTE device **240** also avoids free surface and flutter problems in the event the actuator assembly **320** fails.

Moreover, since the air loads are carried mostly by the wing **130**, the actuator assembly **320** may be configured primarily to overcome friction forces associated with sliding the DTE device **240**. As a result, size of the actuator assembly **320** may be reduced to the point where it can be located entirely within the wing box **330**. In this case, a fairing is not used to cover the actuator assembly **320**, whereby collateral impact associated with the fairing is avoided.

Reference is now made to FIG. 4, which illustrates an example of a trailing edge **210** and a DTE device **240** that is deployed. An upper surface **410** of the DTE device **240** is visible. The upper surface **410** has a plurality of ribs **420**, which extend in a chordwise direction. The ribs **420** provide chordwise stiffness of the DTE device **240**. The ribs **420** of the DTE device **240** make contact with the aft lower surface **430** of the trailing edge **210**. Upward flight loads on the DTE device **240** are transmitted by the ribs **420** to the trailing edge **210** and are reacted by the wing **130**.

Additional reference is now made to FIG. 5, which illustrates ribs **510** on an aft lower surface of the trailing edge **210**. These ribs **510** extend in a chordwise direction. In some configurations, the ribs **510** on the after lower surface of the trailing edge device **210** may be interlocked with ribs on the upper surface of the DTE device **240**.

FIG. 3C shows a configuration in which ribs **340** on the upper surface of the DTE device **240** are interlocked with ribs **350** on an aft lower surface of the trailing edge **210**. These interlocked ribs **340** and **350** provide chordwise stiffness and prevent jamming when loads are not uniform spanwise. With these loads paths, the risk of flutter is reduced.

Returning to FIG. 5, a cover **520** over a lower surface of the DTE device **240** provides a curved sliding surface for the DTE device **240**. The cover **520** may also react air loads. For instance, the cover **520** may react a down load on the DTE device **240**. The cover **520** may be fastened to the trailing edge **210** by fasteners **530**. The fasteners **530** extend through slots **540** in the DTE device **240** and may limit lateral movement of the DTE device **240**.

Reference is now made to FIG. 6. In some configurations, a cover **610** may be part of the trailing edge **210**. In the configuration shown in FIG. 6, the DTE device **240** slides along a surface **622** of a lower portion **620** the trailing edge **210**.

Fasteners **630** fasten the cover **610** to the lower portion **620**. The fasteners **630** extend through slots **640** in the DTE device **240** and may limit lateral movement of the DTE device **240**.

Although the DTE devices **240** in FIGS. **3A**, **3B**, **4**, **5** and **6** are all shown with curved stiffened panels, the DTE device **240** is not so limited. For instance, the DTE device **240** may include a stiffened panel that is substantially straight

Reference is made to FIG. **7**, which illustrates a DTE device **240** that includes a substantially straight stiffened panel **710**. An actuator assembly **320** including an actuator **720** and an actuator linkage **730** move the DTE device **240** between a stowed position and a fully deployed position. When deployed, the DTE device **240** has a fixed divergence angle (α). When stowed, the DTE device **240** is contained entirely within the trailing edge **210**.

The actuator linkage **730** is along the direction of travel of the DTE device **240**, which is mostly normal to the air load direction. Sized to overcome friction forces associated with sliding the DTE device **240**, the actuator **720** and the actuator linkage **730** may be located entirely within the trailing edge **210**.

Reference is now made to FIG. **8A**, which illustrates an example of a wing **130** including a wing box **810**, a leading edge **820**, and a trailing edge **210**. The trailing edge **210** includes moveable flight control surfaces such as an inboard flap **830**, flaperon **832**, outboard flap **834**, and aileron **836**. The trailing edge **210** further includes a fixed surface including a tip **838**.

The wing **130** further includes a plurality of DTE devices **240**. The surfaces **830** to **838** of the trailing edge **210** may include zero, one or multiple DTE devices **240**. In the configuration shows in FIG. **8A**, the tip **838** has no DTE devices **240**, the flaperon **832** has a single DTE device **240**, the inboard flap **830** has multiple DTE devices **240**, the outboard flap **834** has multiple DTE devices **240**, and the aileron

836 has multiple DTE devices **240**. In another configuration, DTE devices **240** may be included from the root of the trailing edge **210** all the way out to the tip **838**.

Each DTE device **240** is slideable between a stowed position and a fully deployed position. The DTE devices **240** may be stowed entirely within their
5 respective surfaces of the trailing edge **210**. The DTE devices **240** may be deployed fully or partially under their respective surfaces of the trailing edge **210**.

Each of the DTE devices **240** may be provided with an actuator for independent control. Each actuator may be housed within its respective trailing edge surface **830-838**.

10 For example, FIG. **8B** illustrates a portion of the aileron **836** and a rear spar **812** of the wing box **810**. Each of the DTE devices **240** may be independently controllable. For instance, each trailing edge device **240** may be provided with an actuator **840** that is housed with the aileron **836**.

Reference is now made to FIG. **9**, which illustrates a method of enhancing
15 performance of an aircraft. The method includes selectively sliding one or more divergent trailing edge devices along a trailing edge of each aircraft wing to reduce lift over drag (L/D) of each wing (block **910**). For example the DTE devices may be deployed to reduce drag and/or alleviate load. Any divergent trailing edge devices that are not deployed are stowed entirely within the trailing edges (block **920**).

20 Deploying selected DTE devices during different phases of the flight may be advantageous. Depending on wing loading due to gross weight, center of gravity, speed and altitude, the DTE devices may be scheduled to deploy to optimize wing loading and aerodynamic efficiency.

EMBODIMENTS IN WHICH AN EXCLUSIVE PROPERTY OR PRIVILEGE IS CLAIMED ARE DEFINED AS FOLLOWS:

1. An apparatus comprising:

a wing, the wing including:

an upper surface and a lower surface opposite the upper surface;

a trailing edge;

a compartment defined between the upper surface and the lower surface; and

an opening for the compartment defined in the lower surface, the opening spaced apart from the trailing edge such that a portion of the lower surface is disposed between the opening and the trailing edge; and

a divergent trailing edge panel slidably disposed within the compartment, the divergent trailing edge panel slideable between:

a stowed position in which the divergent trailing edge panel is disposed within the compartment; and

a deployed position in which the divergent trailing edge panel extends through the opening and below the portion of the lower surface between the opening and the trailing edge, the divergent trailing edge panel increasing lift over drag of the wing when in the deployed position.

2. The apparatus of claim 1, wherein a chord length of the divergent trailing edge panel is between about 1% and about 6% of a chord length of the wing.

3. The apparatus of claim 1 or 2, wherein the wing includes a movable flight control surface defining at least a portion of the trailing edge.
4. The apparatus of claim 3, wherein the compartment is defined within the moveable flight control surface.
5. The apparatus of any one of claims 1 to 3, wherein the compartment is defined within a fixed surface section of the wing.
6. The apparatus of any one of claims 1 to 5, wherein the compartment is near the trailing edge.
7. The apparatus of any one of claims 1 to 6, wherein a divergence angle between the divergent trailing edge panel and the lower surface varies as the divergent trailing edge panel is deployed from the stowed position to the deployed position.
8. The apparatus of any one of claims 1 to 7, further including an actuator disposed in the wing to move the divergent trailing edge panel between the stowed position and the deployed position.
9. The apparatus of any one of claims 1 to 8, wherein the divergent trailing edge panel is curved.
10. The apparatus of any one of claims 1 to 8, wherein the divergent trailing edge panel is straight.
11. The apparatus of any one of claims 1 to 10, wherein an upper surface of the divergent trailing edge panel includes ribs to engage the upper surface of the wing.
12. The apparatus of claim 11, wherein the upper surface of the wing includes ribs to interlock with the ribs of the divergent trailing edge panel.

13. The apparatus of any one of claims 1 to 12, further comprising a cover removably coupled to the wing.
14. The apparatus of claim 13, wherein the cover defines a portion of the lower surface fore of the opening.
15. The apparatus of claim 13, wherein the cover defines a portion of the upper surface of the wing.
16. The apparatus of claim 14 or 15, wherein the cover provides a sliding surface for the divergent trailing edge panel.
17. The apparatus of any one of claims 13 to 16, wherein the divergent trailing edge panel includes a plurality of slots, and wherein the cover is removably coupled to the wing via a plurality of fasteners extending through the slots.
18. The apparatus of any one of claims 1 to 17, wherein the divergent trailing edge panel includes an aft edge and a fore edge opposite the aft edge.
19. The apparatus of claim 18, wherein, in the stowed position, the aft edge of the divergent trailing edge panel is disposed in the opening and aligned with the lower surface.
20. The apparatus of claim 18 or 19, wherein, in the deployed position, the aft edge of the divergent trailing edge panel is spaced vertically below the trailing edge.
21. The apparatus of any one of claims 1 to 20, wherein the compartment has a curved profile.
22. The apparatus of any one of claims 1 to 21, wherein the compartment is a first compartment, the divergent trailing edge panel is a first divergent trailing edge panel, and the opening is a first opening,

the wing further including a second compartment and a second opening for the second compartment defined in the lower surface, and

the apparatus further including a second divergent trailing edge panel slidably disposed within the second compartment and slideable between a stowed position and a deployed position.

23. The apparatus of claim **22**, further comprising a first actuator to control the first divergent trailing edge panel and a second actuator to control the second divergent trailing edge panel, the first and second actuators independently controllable.

24. An aircraft comprising:

a wing including a moveable flight control surface having:

a trailing edge;

a compartment defined between an upper surface of the moveable flight control surface and a lower surface of the moveable flight control surface; and

an opening for the compartment defined in the lower surface, the opening spaced apart from the trailing edge such that a portion of the lower surface is disposed between the opening and the trailing edge;

a divergent trailing edge panel disposed within the compartment, the divergent trailing edge panel slideable between:

a stowed position in which the divergent trailing edge panel is disposed within the compartment; and

a deployed position in which the divergent trailing edge panel extends from the compartment and is disposed below the moveable flight control surface; and

an actuator to control the divergent trailing edge panel independently of the moveable flight control surface.

- 25.** The aircraft of claim **24**, wherein, in the stowed position, an aft edge of the divergent trailing edge panel is disposed in the opening and aligned with the lower surface.
- 26.** The aircraft of claim **24**, wherein, in the deployed position, an aft edge of the divergent trailing edge panel is spaced vertically below the trailing edge.
- 27.** The aircraft of any one of claims **24** to **26**, wherein the compartment is a first compartment and the divergent trailing edge panel is a first divergent trailing edge panel, the aircraft further including:

a second divergent trailing edge panel disposed within a second compartment in the moveable flight control surface, the second divergent trailing edge panel slideable between:

a stowed position in which the second divergent trailing edge panel is disposed within the second compartment; and

a deployed position in which the second divergent trailing edge panel extends from the second compartment and disposed below the moveable flight control surface.

- 28.** A method comprising:

sliding a divergent trailing edge panel through a compartment defined in an aircraft wing and through an opening in a lower surface of the wing to reduce lift over drag (L/D) of the wing, the compartment defined between an upper surface and the lower surface of the wing, the opening defined in the lower surface and spaced apart from a trailing edge of the wing such that a portion of the lower surface is disposed between the opening and the trailing edge.

29. The method of claim **28**, further comprising retracting the divergent trailing edge panel through the opening back into the compartment such that an aft edge of the divergent trailing edge panel is disposed in the opening and aligned with the lower surface.
30. The method of claim **28**, wherein sliding the divergent trailing edge panel through the compartment and through the opening comprises sliding the divergent edge panel such that an aft edge of the divergent trailing edge panel is spaced vertically below the trailing edge of the wing.
31. The method of any one of claims **28** to **30**, wherein the compartment is defined within a moveable flight control surface of the wing.
32. The method of any one of claims **28** to **31**, wherein the divergent trailing edge panel is a first divergent trailing edge panel, the compartment is a first compartment, and the opening is a first opening, the method further comprising selectively sliding a second divergent trailing edge panel through a second compartment defined in the wing and through a second opening in the lower surface of the wing to vary the L/D of the wing.

FIG. 1

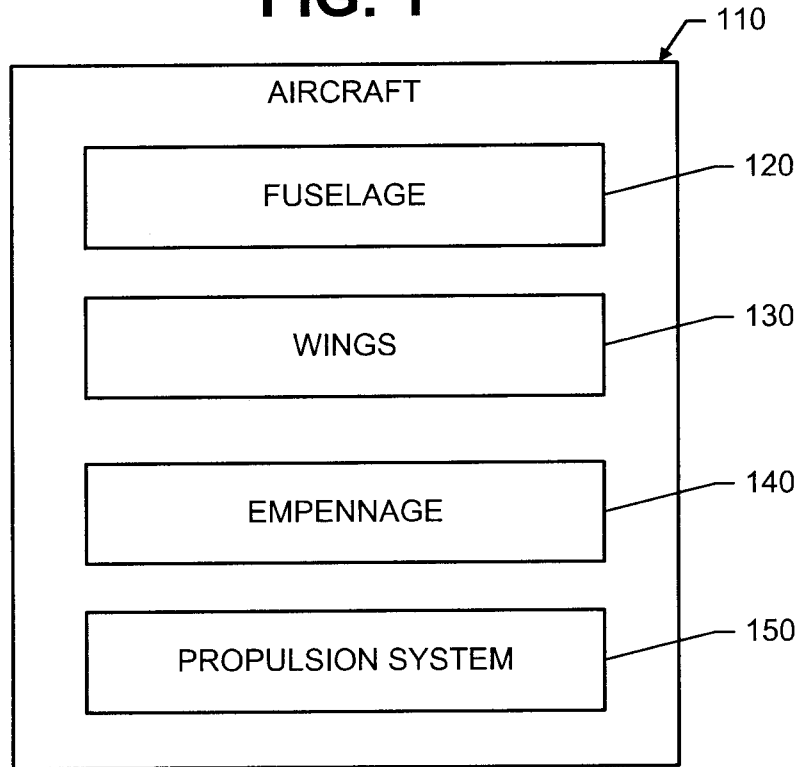
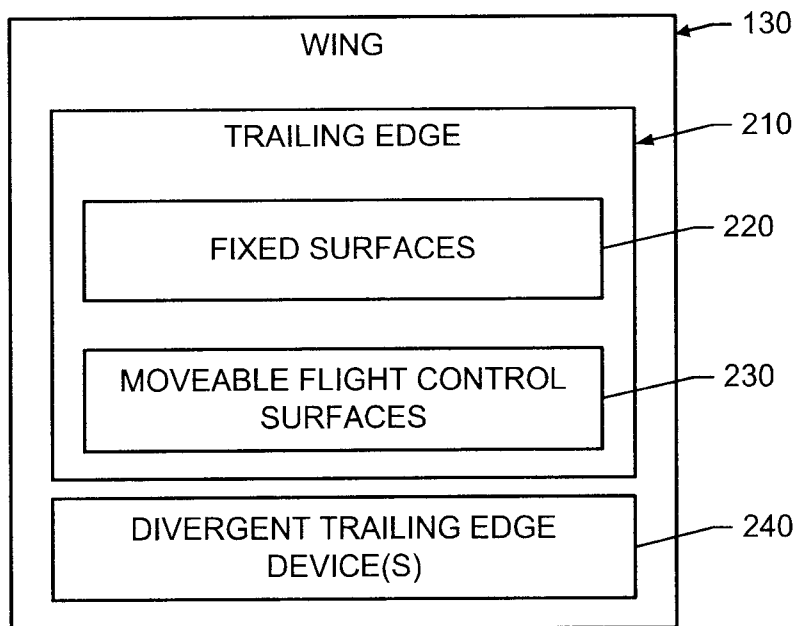

FIG. 2



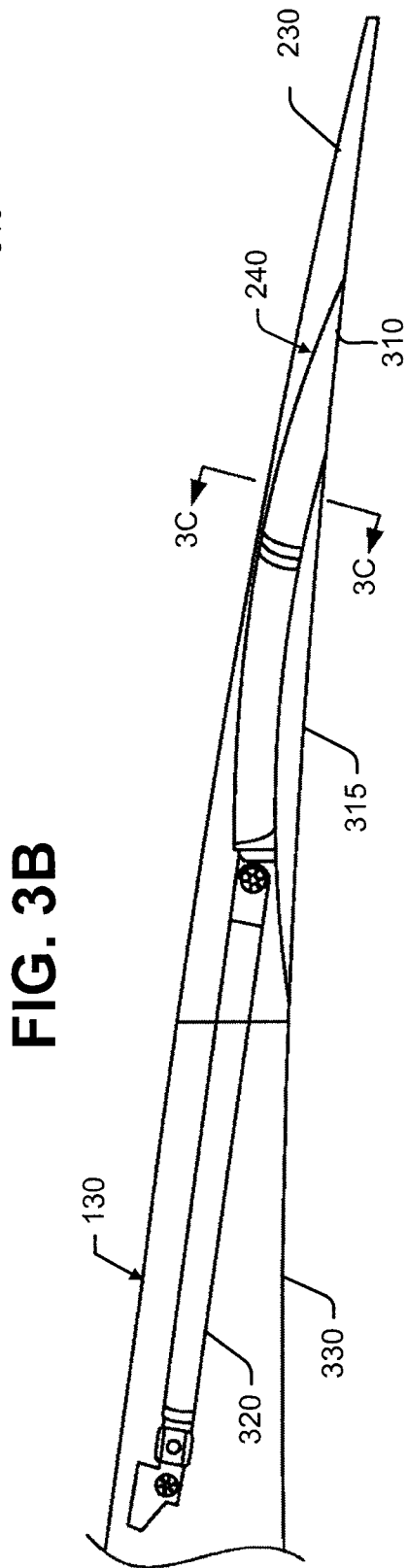
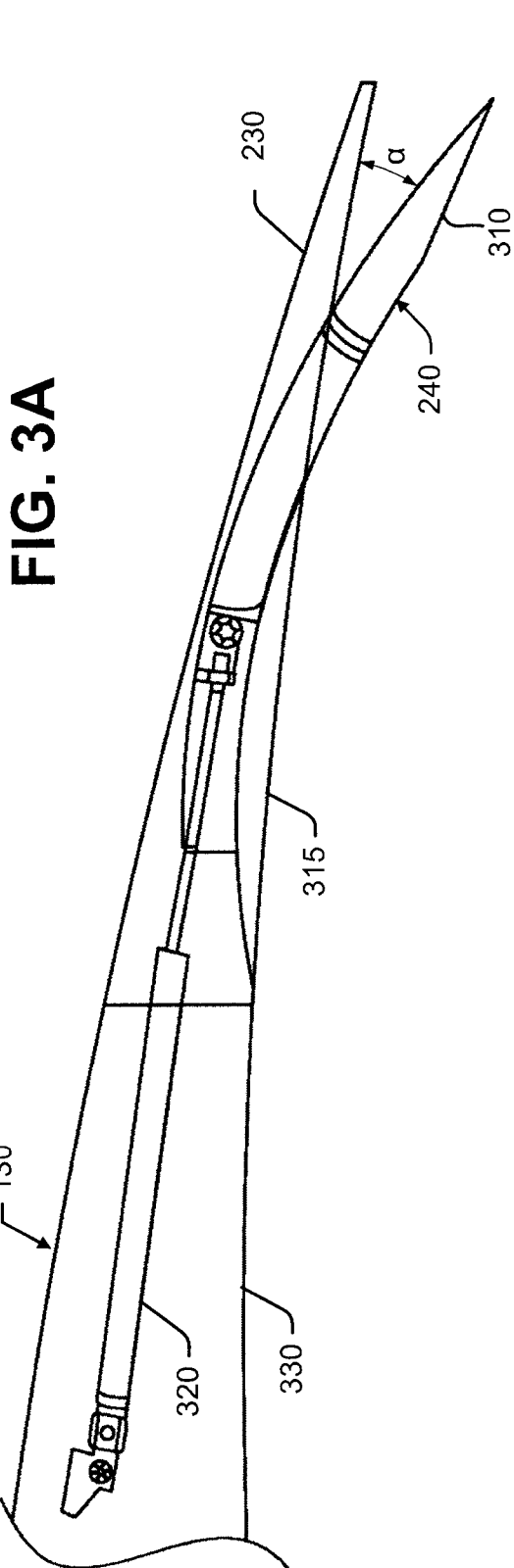

FIG. 3C

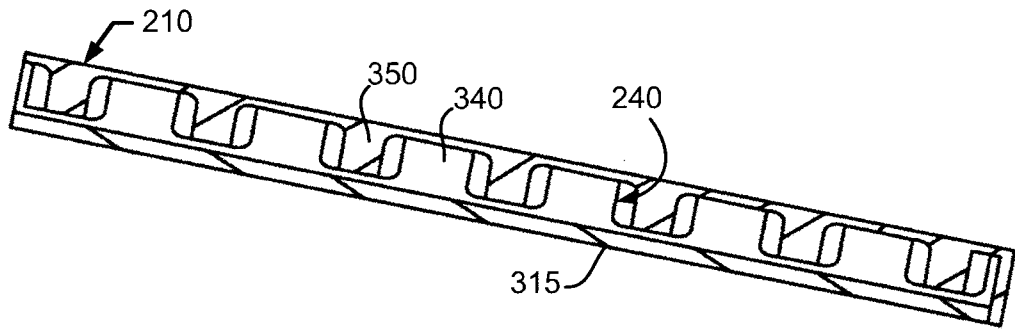
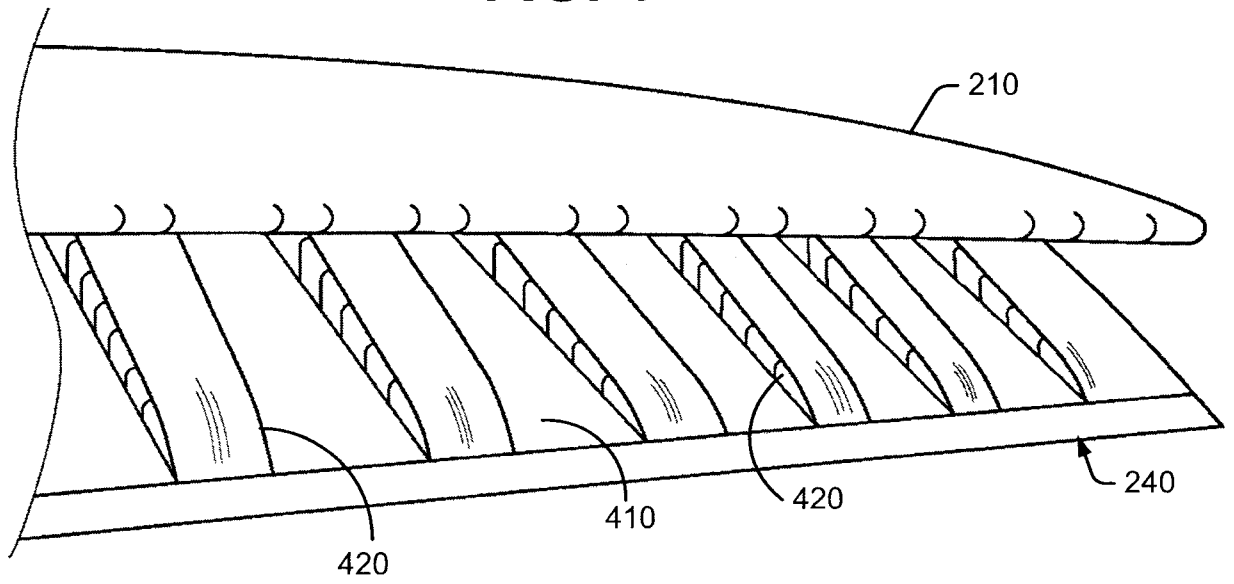

FIG. 4



4/7

FIG. 5

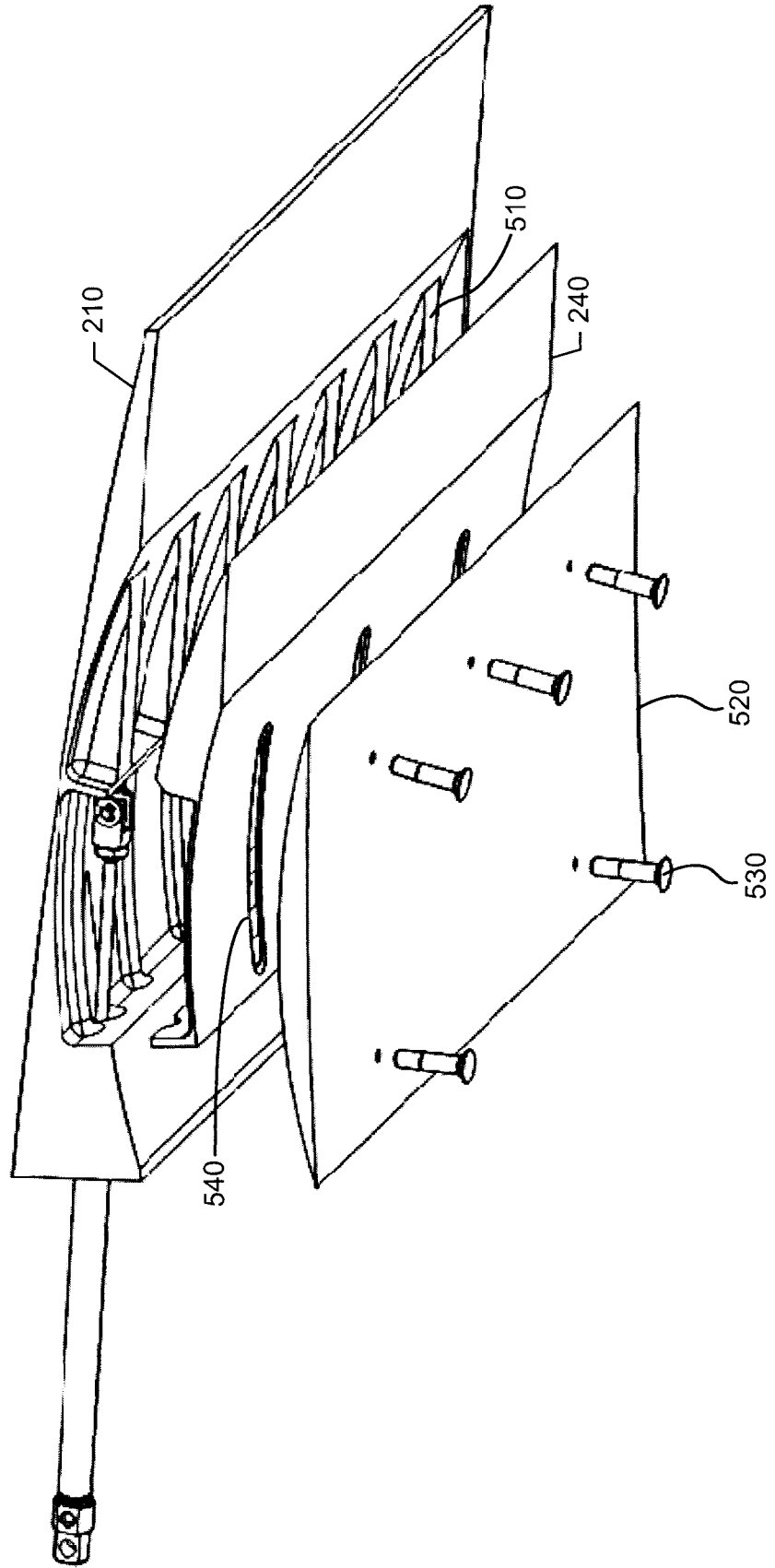

FIG. 6

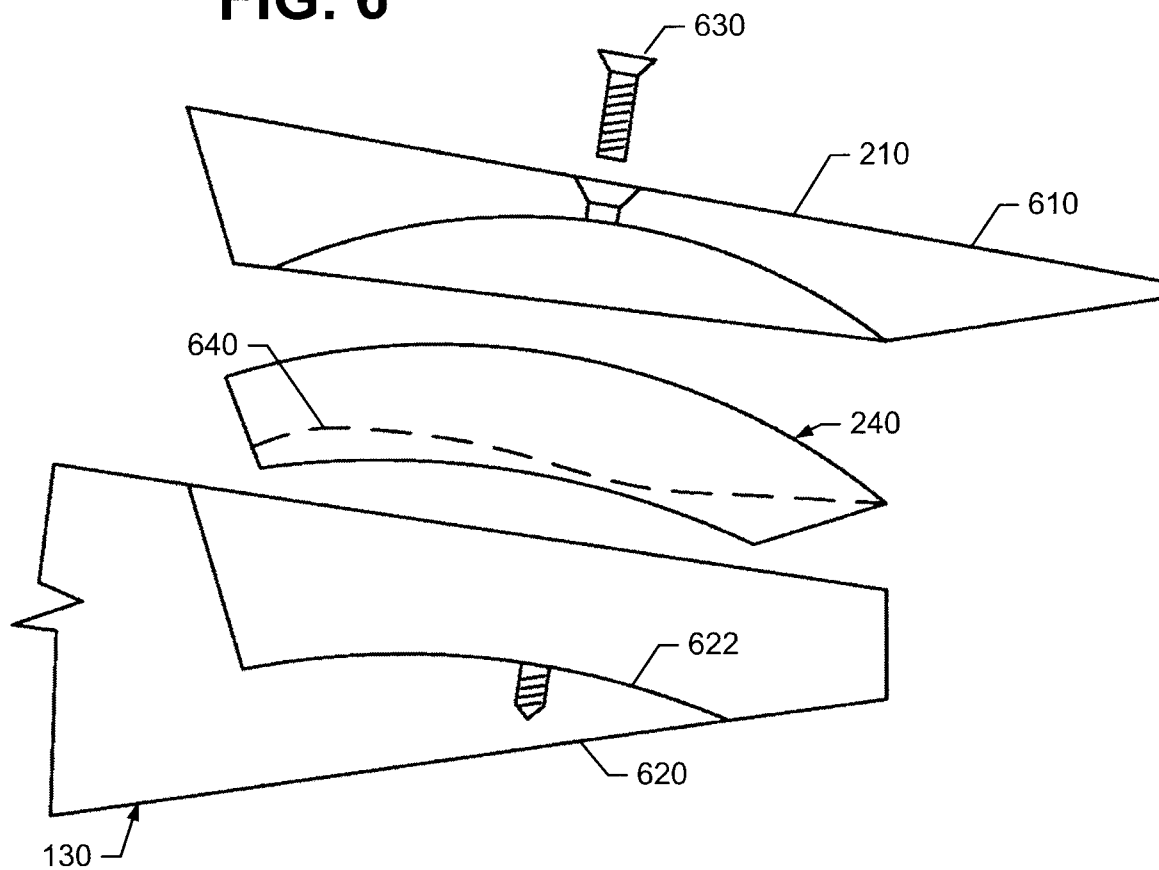
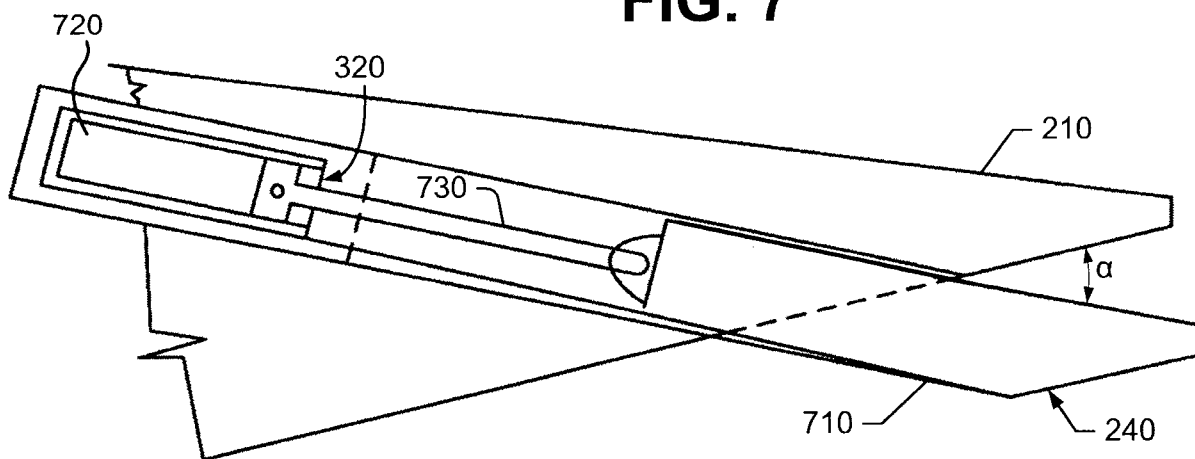

FIG. 7



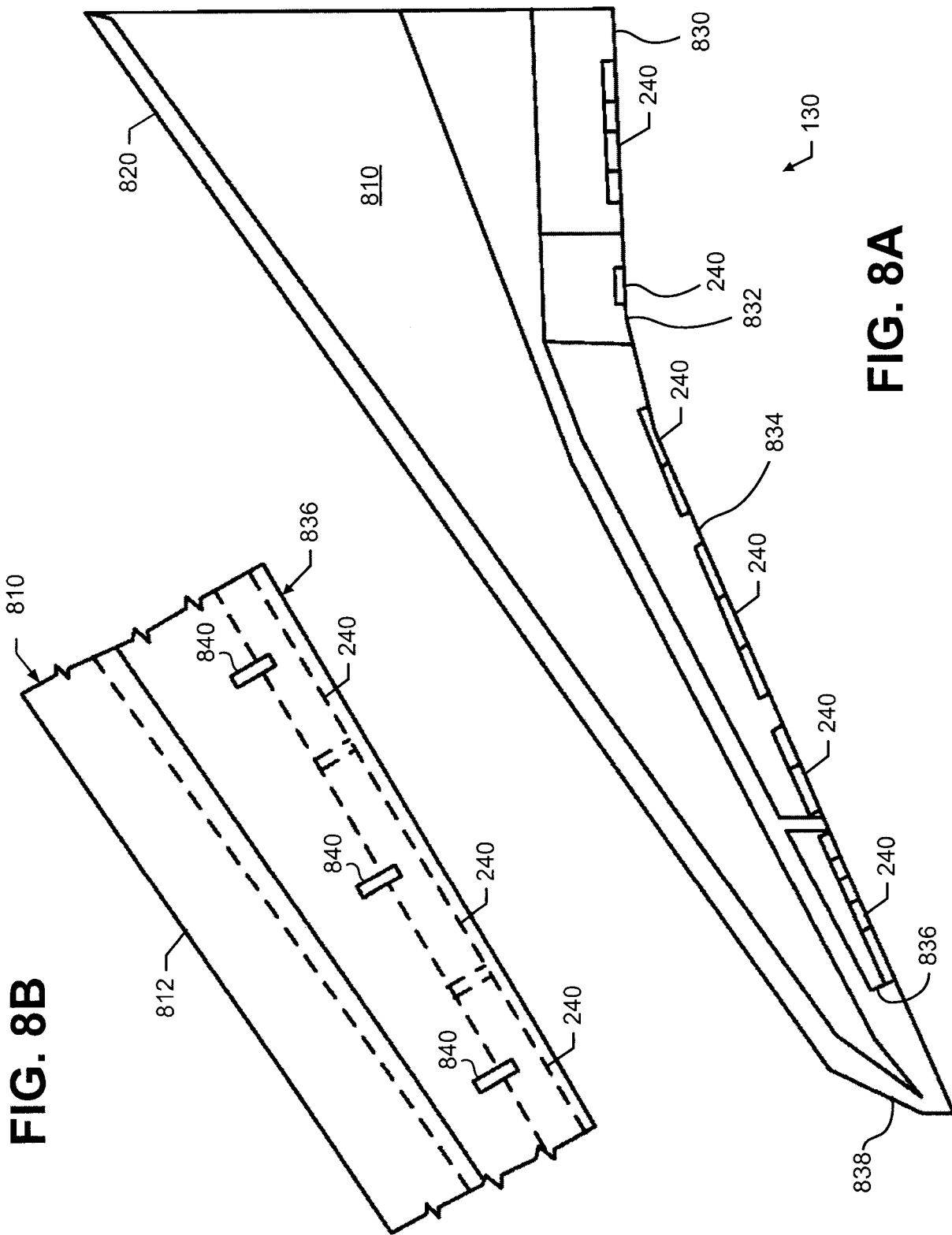

FIG. 8B

FIG. 8A

130

FIG. 9

