

*J. M. Story,
Paddle Wheel.*

N^o 56,118.

Patented July 3, 1866.

Fig. 1.

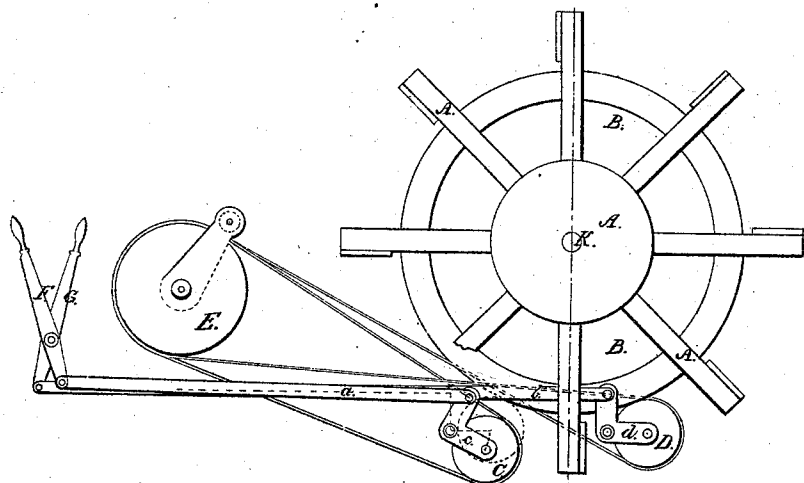

Fig. 3.

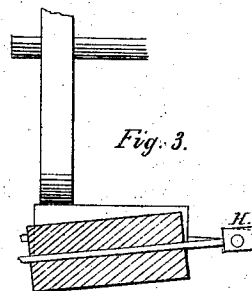
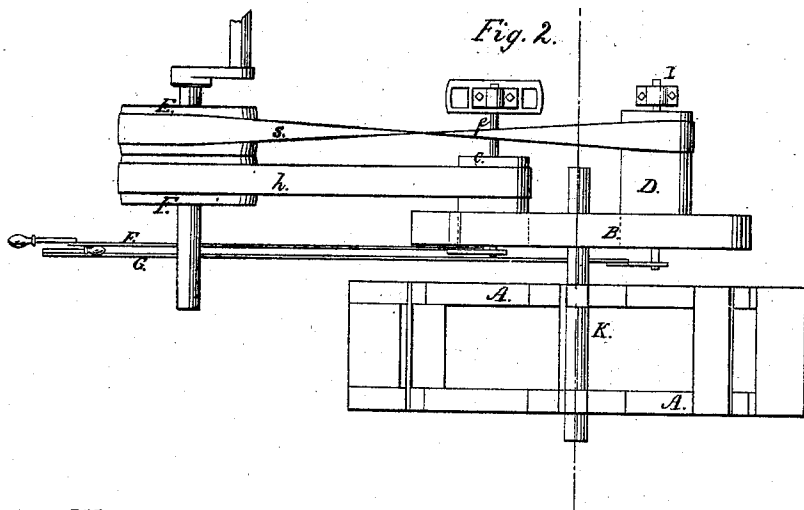

Fig. 2.



*Witnesses,
H. Douglass
John H. Poggendorf*

*Inventor:
Joseph M. Story*

UNITED STATES PATENT OFFICE.

JOSEPH M. STORY, OF CINCINNATI, OHIO.

IMPROVED MEANS FOR DRIVING PADDLE-WHEELS.

Specification forming part of Letters Patent No. 56,118, dated July 3, 1866.

To all whom it may concern:

Be it known that I, JOSEPH M. STORY, of Cincinnati, county of Hamilton, and State of Ohio, have invented a new and Improved Method of Driving the Paddle-Wheels of Boats, whereby the power is applied nearer the periphery of the wheel than in the usual crank attachment, thereby driving a wheel of the same dimensions with much less power than in the ordinary manner; and I do declare that the following is a full and exact description thereof, reference being had to the accompanying drawings and the letters of reference marked thereon.

Figure 1 is a side elevation of my invention, showing the paddle-wheel A, the large friction-wheel B, the two small driving friction-wheels C D, the driving-pulley E, the levers F G, for the purpose of applying the power to the large friction-wheel B by means of connecting-shafts *a b* and small levers *c d*. The arm A^x of paddle-wheel is represented broken off, in order to show more plainly the operation of the friction-wheels C D and levers *c d*. The operation of these levers and friction-wheels is shown in red lines. The crank J (shown in dotted lines) indicates the point at which the pitman of the engine is attached.

Fig. 2 is a plan or top view, showing the paddle-wheel A, the friction-wheels B C D, the pivot-boxes H I, which support the end of the shafts *e f*, opposite the movable ends, which are supported and operated by the levers *c d*, Fig. 1, the belts *g h*, running from the driving-pulleys E E to friction-wheels C D, the levers F G, and their connections with friction-wheels C D.

Fig. 3 is a sectional view of small wheel C, taken through center line, *x x*, Fig. 1, showing the operation of the same with dotted lines P P. The box H is a pivot-box, which permits the movement of the shaft by the levers *c d*, Fig. 1.

In order that others may fully understand and be enabled to construct and use my in-

vention, I will proceed to explain the operation of the same.

I use the ordinary form of paddle-wheels, and upon the shaft S, Fig. 1, I put a friction-wheel, B, as large as the nature of the case will admit, and below this wheel I use two smaller friction-wheels, C D, for the purpose of driving it. One of these wheels, C, drives the large wheel in one direction, the other, D, driving it in the reverse direction. These wheels C D are placed on shafts *e f*, Fig. 2, that are supported by stationary pivot-boxes at one end, H I, Fig. 2, and pivot-boxes attached to the levers *c d* at the opposite end. This is for the purpose of communicating and discontinuing the power to the large wheel at the will of the operator; also, for reversing the direction of the wheel. The levers *c d* are operated by means of the shafts *a b*, which connect them with the levers F G, and these are worked by the operator (who may be stationed in the pilot-house or other convenient place) by means of ropes attached to them and connecting with any kind of apparatus by which the necessary power can be applied to operate the levers and friction-wheels C D. The large friction-wheel B is driven by small wheels C D, either forward or backward, by bringing either the one or the other in contact with it. The wheels C D are driven by means of belts *g h*, running from the driving-pulley E. One of these belts being crossed gives opposite directions to the wheels C D.

What I claim as new, and desire to secure by Letters Patent, is—

Applying the power to the paddle-wheels of boats near the periphery of the same by means of friction-wheels and levers, in the manner and for the purpose substantially as herein set forth.

JOSEPH M. STORY.

Witnesses:

H. DOUGLASS,
JOHN H. BOGART.