

(No Model.)

4 Sheets—Sheet 2.

O. R. CHASE.
LOZENGE MACHINE.

No. 376,068.

Patented Jan. 10, 1888.

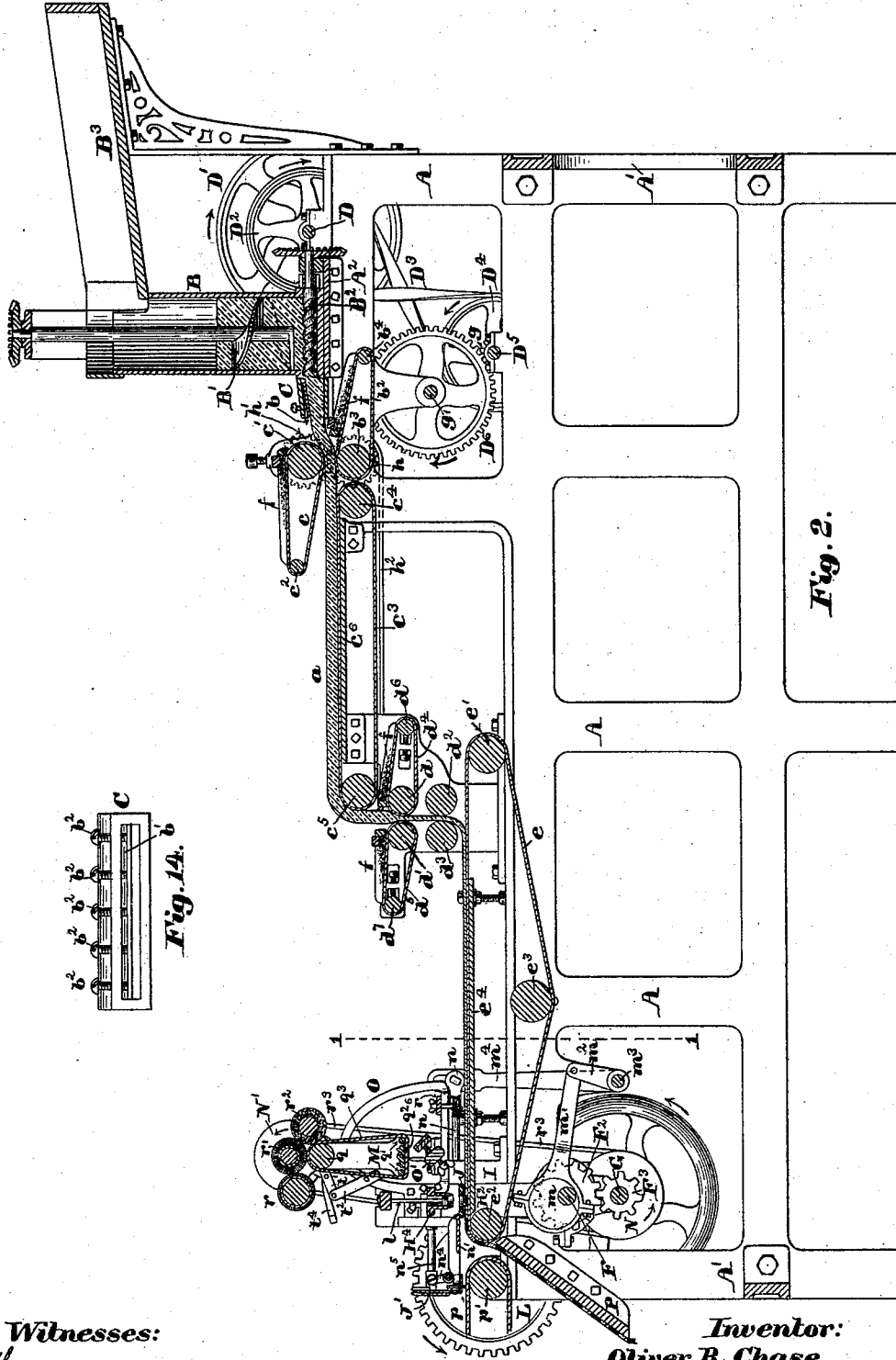

Fig. 2.

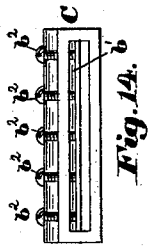

Fig. 14.

Witnesses:
Walter E. Lombard.
Chas. K. Stearns.

Inventor:
Oliver R. Chase,
 by *N. C. Lombard.*
 Attorney.

O. R. CHASE.
LOZENGE MACHINE.

No. 376,068.

Patented Jan. 10, 1888.

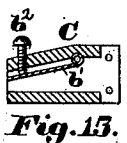
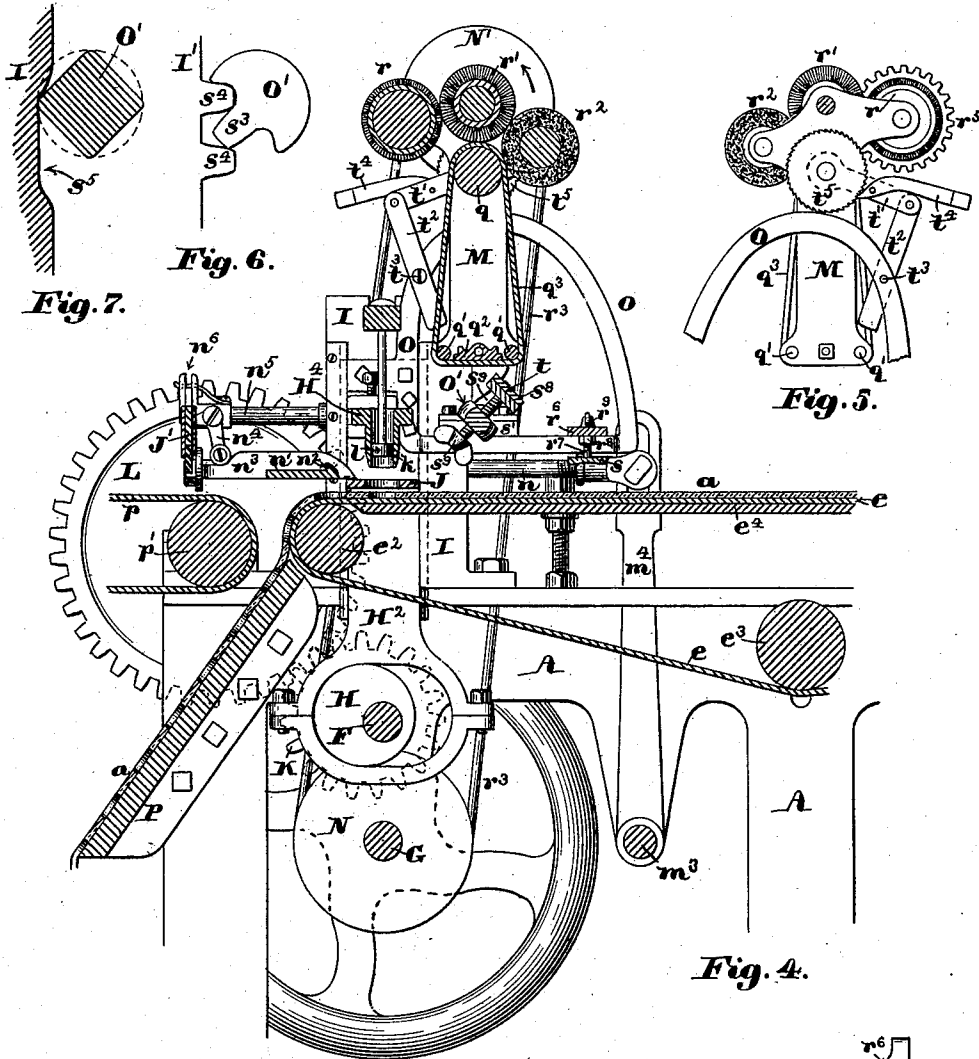

Fig. 13.

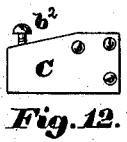

Fig. 12.

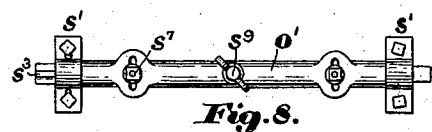

Fig. 8.

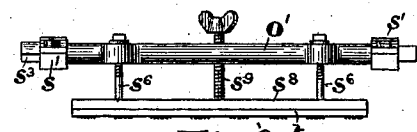

Fig. 9.

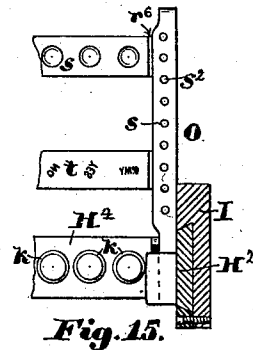

Fig. 15.

Witnesses:
Walter G. Lombard.
Chas. H. Stearns.

Inventor:
Oliver R. Chase,
 by *N. P. Lombard*
 Attorney.

UNITED STATES PATENT OFFICE.

OLIVER R. CHASE, OF BOSTON, MASSACHUSETTS.

LOZENGE-MACHINE.

SPECIFICATION forming part of Letters Patent No. 376,068, dated January 10, 1888.

Application filed November 24, 1886. Serial No. 219,750. (No model.)

To all whom it may concern:

Be it known that I, OLIVER R. CHASE, of Boston, in the county of Suffolk and State of Massachusetts, have invented certain new and useful Improvements in Machines for Manufacturing Lozenges, of which the following, taken in connection with the accompanying drawings, is a specification.

My invention relates to machines for manufacturing confectionery, and especially confectionery lozenges, and is an improvement upon the machines described in Letters Patent Nos. 279,132 and 279,913, granted to me June 12, 1883, and June 26, 1883, respectively; and it consists in certain novel features of construction, arrangement, and combination of parts, which will be readily understood by reference to the description of the drawings and to the claims to be hereinafter given.

The machine described in Letters Patent No. 279,132 was designed originally for feeding the sugar-paste into sticks or rods; but by an improvement in the discharging-nozzle now embodied in this application it has been used for molding the paste into a sheet or ribbon of, say, six or eight inches in width and about one-half an inch in thickness, more or less. The sheet or ribbon so formed was then taken by hand from said machine and transferred to the feeding-apron of the machine described in Letters Patent No. 279,913, where it was further reduced in thickness, planished, and then cut into lozenges. This mode of operation involved the running of two independent machines and an extra handling of the material, which my present invention obviates.

In the drawings, Figure 1 is a side elevation of a machine embodying my invention. Fig. 2 is a longitudinal vertical section of the same. Fig. 3 is a transverse vertical section on line 11 on Figs. 1 and 2, looking toward the delivery end of said machine, said figure being drawn to an enlarged scale. Fig. 4 is a vertical longitudinal section of a portion of the delivery end of the machine, also drawn to an enlarged scale. Fig. 5 is a side elevation of the upper portion of Fig. 4, looking in the opposite direction to that in which Fig. 4 is viewed, and drawn to the same scale as Figs. 3 and 4. Figs. 6 and 7 are details illustrating the manner of vibrating the printing-form and holding it in position while giving an im-

pression or taking ink. Figs. 8 and 9 are respectively a plan and an elevation of the oscillating type-carrying bar. Figs. 10 and 11 are respectively an elevation and a transverse section of the stripper-bar. Figs. 12, 13, and 14 are respectively an end elevation, a transverse section, and a front elevation of the rectangular discharge-nozzle for forming the sheet of sugar-paste; and Fig. 15 is an inverted plan of a portion of the cutters, the embossing and printing bars, and the bail-like stand for carrying said bars. Fig. 16 is a partial longitudinal section illustrating a modification, to be hereinafter referred to.

In the drawings, A A are the side frames of the machine, connected together by the tie-girts A' A' and the plates A² and P, as shown in Fig. 2.

Upon the plate A² is mounted the vertical cylinder B, provided with the revolving screw-piston B' and one or more horizontal screw-feeders, B², all constructed, arranged, and operating substantially as described in the said Letters Patent No. 279,132, and with the inclined feed-table B³, from which the material is fed to the cylinder B, from which it is discharged in the form of a sheet or ribbon, *a*, through the rectangular opening *b* in the nozzle C, as shown in Fig. 2. The nozzle C has pivoted therein the plate *b'*, the free or outer edge of which may be adjusted by the set-screws *b²*, for the purpose of varying the thickness of the sheet of material that can be delivered therefrom, as shown in Figs. 2, 13, and 14. The sheet of material *a*, when delivered from said nozzle, falls upon the inner end of the apron *b²*, mounted upon the rolls *b³* and *b⁴*, and is carried by said apron beneath the endless band or apron *c*, mounted upon the rolls *c'* and *c²*, and upon the moving apron or endless band *c³*, mounted upon the rolls *c⁴* and *c⁵*, as shown in Fig. 2. The sheet of material, as it passes from the apron *c³*, where said apron passes around the roll *c⁵*, is turned downward between the pressure-rolls *d* and *d'*, where it is reduced in thickness and compacted, and then between the planishing-rolls *d²* and *d³*, and deposited upon the moving apron *e*, mounted upon the rolls *e'*, *e²*, and *e³*, as shown.

The rolls *d* and *d'* are partially surrounded by the endless bands or aprons *d²* and *d³*, respectively, which extend to and partially sur-

round the rolls d^6 and d^7 , respectively, as shown. The aprons b^2 , c , d^1 , and d^5 each have placed thereon a quantity of flour or powdered starch within a shallow hopper or receptacle, f , of which said apron forms a moving bottom, as described in said Letters Patent No. 279,913, whereby the sheet or ribbon of paste has deposited upon each side thereof a thin coating of said flour or starch to prevent it from adhering to any of the aprons or the planishing-rolls. The aprons b^2 , c , d^1 , and d^5 may be made taut by adjusting the rolls b^4 , c^2 , d^6 , and d^7 in any well-known manner.

The screw pistons or feeders B^1 and B^2 are driven from the shaft D in the same manner as described in the before-mentioned Letters Patent No. 279,132, said shaft D being driven by a belt (not shown) leading from the driving-pulley D^1 to any suitable counter-shaft. (Not shown.)

The shaft D has mounted thereon the pulley D^2 , from which the belt D^3 leads to the pulley D^4 , mounted upon the shaft D^5 , which has its bearings in the frames A A, and has secured thereon the pinion g , which engages with and imparts motion to the gear-wheel D^6 on the shaft g^1 , also mounted in bearings in the frames A A, and having mounted thereon the pinion g^2 , which engages with and imparts motion to the gear-wheel B, mounted upon one end of the shaft of the roll b^3 , the opposite end of which shaft has secured thereon the gear-wheel h , which engages with and imparts motion to the gear-wheel h^1 , mounted upon the shaft of the roll c^1 , as shown. The shaft of the roll b^3 has mounted thereon a pulley, from which the belt h^2 leads to a similar pulley on the roll c^5 , for the purpose of revolving said roll c^5 in unison with the roll b^3 and imparting motion to the apron c^3 , for conveying the sheet of paste a to a position to be delivered to the pressure-rolls d and d^1 , as shown. The upper portions of the endless belts c^3 and e are supported between their carrying-rolls by the bed-plates or tables c^6 and c^7 , respectively, as shown in Figs. 2 and 3.

Motion is imparted to the rolls d , d^1 , d^2 , and d^3 and the aprons d^4 and d^5 from the roll c^5 by means of the gear-wheels i^5 , i^6 , i^7 , i^8 , i^9 , i^{10} , i^{11} , and i^{12} .

The endless apron e has an intermittent motion imparted thereto by means of the crank-pin i , set in the disk i^1 , mounted upon one end of the shaft F, the connecting-rod F^1 , the lever i^2 , the pawl i^3 , and the ratchet-wheel i^4 , mounted on the shaft of the roll c^1 in substantially the same manner as described in said Letters Patent No. 279,913.

The shaft F has mounted thereon the gear-wheel F^2 , with which the pinion F^3 , mounted upon the shaft G, engages, to impart to said shaft F a rotary motion, said shaft G being revolved by means of the pulley G^1 , mounted thereon, and a belt leading therefrom to a suitable counter-shaft, which may be the same from which the shaft D is driven or an independent one, as may be preferred, care being

taken to so proportion the several pulleys that said shafts G and D shall be driven at the proper relative speed.

The shaft F has mounted thereon two eccentrics, H and H', which work in slots in the lower ends of the vertical bars H^2 and H^3 , respectively, in such a manner as to impart to said bars a vertical reciprocating motion, said bars being fitted to slide in dovetailed bearings in the inner faces of the stands I and I', bolted to the upper edges of the frames A A, as shown. To these bars H^2 and H^3 is bolted the horizontal bar H^4 , having set therein a series of tubular cutters, k k , which project downward therefrom and surround the fixed pistons l , suspended from the under side of the fixed bar J, said cutters, when moved downward to cut lozenges from the sheet of material a , passing through holes in the fixed bar J, supported upon the raised ribs of the bed-plate e^1 , as shown in Fig. 3. The shaft F also has mounted thereon the eccentric m , which works in the strap end of the eccentric-rod m^1 , which in turn is connected to the lever m^2 , firmly secured upon the rocker-shaft m^3 , mounted in bearings in the frames A and carrying the two arms m^4 m^4 , the free ends of which are connected to the rods n n , having bearings in the stands I and I' and carrying at their opposite ends the reciprocating lozenge-carrying plate n^1 , all constructed and operating substantially as described in said Letters Patent No. 279,943, except that the plate n^1 , instead of having a jointed flap, as described in said patent, has a fixed raised rib, n^2 , upon its inner edge, and except, also, that instead of the lozenge being brushed from the inner edge of said plate as said plate is moving outward, as described in said patent, the lozenge is removed from the outer edge of said plate as it is moving inward after having been moved outward, as will be further described. The plate n^1 also has at each end thereof the raised cam-shaped rib n^3 n^3 , arranged to act upon the pendent arms of the elbow-levers n^4 , pivoted upon the arms or rods n^5 , to move said levers about their pivots and raise or lower the stripper-bar J^1 , fitted to move vertically in slots n^6 , formed in the outer ends of the arms n^5 , as shown in Figs. 1 and 4.

The stripper J^1 is composed of the central plate, o , arranged to fit the slots n^6 and to rest upon the free ends of the horizontal arms of the elbow-levers n^4 at o^1 , the two plates o^2 and o^3 , and the sheet or plate of vulcanized rubber o^4 , all secured together by screws or rivets, as shown in Figs. 10 and 11.

When the plate n^1 is moved outward, after having received from the cutters a series of lozenges, the outer throws of the cams n^3 coming in contact with the pendent arms of the levers n^4 causes the stripper-bar to be raised and held in such raised position until the lozenges on said plate have passed outward beyond the rubber flap of the stripper-bar, when the inner throws of the cams n^3 will have passed from beneath the levers n^4 , when the

stripper-bar will descend to a position with the lower edge of the rubber flap o^4 on a level with the upper surface of the plate n' behind the lozenges, and as the plate n' is again moved inward the lozenges are brushed from said plate by said flap o^4 , or, more literally, the lozenges are prevented from moving back by said flap after they come in contact therewith and the plate is moved from beneath them, and they fall upon the apron p , mounted upon the roll p' and another roll (not shown) that may be at a considerable distance from the roll p' and mounted upon an independent stand, from which apron the lozenges are delivered to a board or receptacle provided for the purpose.

Motion is imparted to the roll p' by the gear-wheels K and L, mounted, respectively, on the shaft F and the shaft of the roll p' , as shown in Figs. 1, 2, 3, and 4.

A standard, M, is firmly secured to the upper end of each of the stands I and I' in such a manner that it may be readily removed by simply slackening the nuts p^2 p^3 and raising said standard to lift the holding-bolt out of the open slot p^3 in the stand I and I'. In bearings formed in the upper ends of the standards M is mounted the roll q , and in bearings formed in the lower ends of said standards are mounted the two smaller rolls, q' q' , and the impression bar or platen q^2 , around which is strained the endless band q^3 of cloth, to serve as a color-pad, upon which coloring-matter for printing mottoes in color upon the lozenges is distributed from the color-roll r by the cylindrical brush r' , assisted by the distributing-roll r^2 , as shown in Fig. 4. Rotary motion is imparted to the brush r' by means of the belt r^3 , leading from the pulley N on the shaft G to the pulley N' on the shaft of said brush, as shown in Fig. 4, and the roll r is revolved by means of the pinion r^4 and gear-wheel r^5 , mounted, respectively, on the shaft of said brush r' and the shaft of said roll r , as shown in Fig. 1.

A bail-like stand, O, is securely bolted to each of the vertically-reciprocating bars H² and H³, so as to move up and down therewith, and upon its lower bar is adjustably secured the bar r^6 , from which is suspended so as to be adjustable vertically, by means of the threaded bolts r^7 and the nuts r^8 and r^9 , the bar s , having formed in or secured to its under side a series of dies adapted to emboss upon the sheet of sugar-paste a row of ornamental figures or designs corresponding in number and distance apart from center to center with the number and distance apart of the cutters k k , said bar r being secured to the stand O at a distance from the center of the line of cutters k k corresponding to a multiple of the distance which said sheet of paste is fed forward at each intermittent movement thereof, all substantially as described in the before-mentioned Letters Patent No. 279,913.

O' is a rocker-shaft mounted in bearings s' , adjustably secured to the lower bar of the stand O by means of bolts arranged to be interchangeably inserted in either of the holes s^2 ,

formed in said bar for the purpose, as shown in Fig. 15.

The shaft O' projects beyond its bearings at each end, and has formed upon one of said projecting portions a tooth, s^3 , which engages with the rock-like teeth s^4 , formed on the edge of the stand I, as said shaft is moved up and down with the stands O, thereby imparting to said shaft a semi-rotation about its axis. (See Fig. 6.) The opposite projecting end of said shaft is made square, and acts in conjunction with the edge of the stand I' to maintain said shaft in a fixed position as to rotation after it has been moved about its axis a half-revolution both in its upward and downward movement, the edge of said stand I' having a recess, s^5 , formed therein at the proper point and of the proper length to permit the rotation of said shaft when the tooth s^3 engages with the teeth s^4 , all as shown in Fig. 7.

The shaft O' has suspended therefrom, by means of the threaded bolts s^6 s^6 and nuts s^7 s^7 , the bar s^8 , which may be adjusted toward or from said shaft by said bolts and nuts and the set-screw s^9 , as shown in Figs. 8 and 9. The bar s^8 has secured thereto the plate t , of type-metal, having cast thereon a series of mottoes, the type composing which project from the surface of said plate, and in the operation of the machine are alternately brought into contact with the endless-belt pad q^3 to take color therefrom and into contact with the upper surface of the sheet of sugar-paste a to print said mottoes thereon, these operations being accomplished by the upward and downward movement of the stands O and the bars H² and H³, caused by the rotation of the eccentrics H and H'.

In order to present a fresh portion of the color-band to the type at each upward movement thereof, the band q^3 has imparted thereto an intermittent movement around the rolls q and q' q' , as follows: The shaft of the roll q has loosely mounted thereon one end of a toggle-link, t' , the opposite end of which is pivoted to one end of the toggle-link t'' , which in turn is pivoted to the stand O at t^3 , as shown in Figs. 4 and 5.

To the link t' is pivoted the pawl t^4 , the toe of which is held in contact with the periphery of the ratchet-wheel t^5 , secured upon the shaft of said roll q by the preponderance of weight in the long or outer arm of said pawl, the whole being so arranged that every downward movement of the stand O causes a partial straightening of the toggle, and as a consequence thereof a partial rotation of the roll q and a movement of the color-band around the same. When the stand O is again moved upward, the pawl t^4 is carried backward over the teeth of the ratchet-wheel t^5 , preparatory to its engaging with another tooth of said wheel, when the stand O is again moved downward.

P is the inclined plate down which the waste from which the lozenges have been cut slides and falls into any suitable receptacle provided for the purpose.

The rubber flap o^4 of the stripper-bar J' has its lower edge divided into a series of sections by vertical slits, as shown in Fig. 10, so as to present less resistance in case a lozenge should stick to the plate n' when said plate is moving backward beneath the stripper-bar.

The operation of my invention, I think, will be readily understood from the foregoing without further explanation.

In some cases I propose to dispense with the aprons e^3 , d^1 , and d^2 and the rolls c^3 , d , d' , d^6 , and d^7 , and place the rolls d^2 and d^3 directly below the rolls b^2 and c^1 , respectively, said rolls b^2 and c^1 being adjusted to the proper distance apart, as shown in Fig. 16, whereby the machine may be considerably reduced in length.

What I claim as new, and desire to secure by Letters Patent of the United States, is—

1. The combination of the intermittently-moving belt or apron e , the shaft F , the eccentrics H and H' , the bars H^2 and H^3 , the series of cutters k , carried by said bars, the oscillating shaft O' , also carried by said bars and having one end thereof squared, and having formed upon the other end the tooth s^2 , the type plate or form t , carried thereby, the stand I , provided with the teeth s^1 , the stand I' , provided with the curved or cut-away place s^3 , the rolls q and q' , the endless color-carrying belt q^2 ,

the ratchet-wheel t^2 , the pawl t^1 , and the toggle-links t^3 , all arranged and operating substantially as described.

2. The combination of the intermittently-moving apron e , the series of vertically-moving cutters k , the horizontally-reciprocating lozenge-receiving plate n' , provided with the cams n^2 , the stripper-bar J' , and the elbow-levers n^1 , all constructed and arranged to operate substantially as described.

3. The stripper-bar J' , provided with the pendent rubber flap o^4 , in combination with the reciprocating carrier-plate n' , the vertically-reciprocating cutters k , and the endless belt e , all arranged and adapted to operate substantially as described.

4. The combination of the apron e , the cutters k , the plate n' , and the stripper-bar J' , provided with the pendent rubber flap o^4 , divided into sections by vertical slits, substantially as described.

In testimony whereof I have signed my name to this specification, in the presence of two subscribing witnesses, on this 2d day of November, A. D. 1886.

OLIVER R. CHASE.

Witnesses:

N. C. LOMBARD,

CHAS. K. STEARNS.