

(No Model.)

W. & W. J. BAUER.  
SPRING BENDING MACHINE.

No. 525,326.

Patented Sept. 4, 1894.

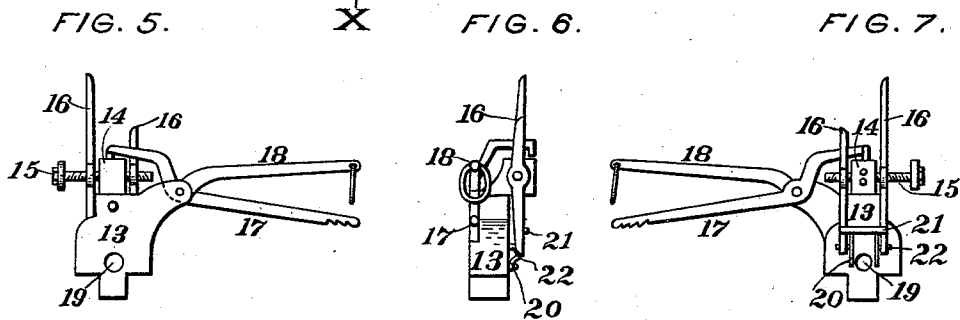
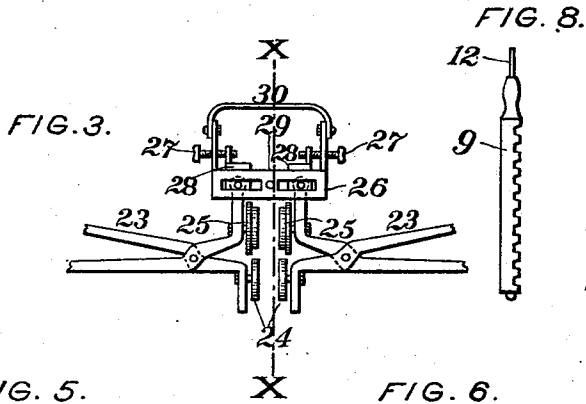
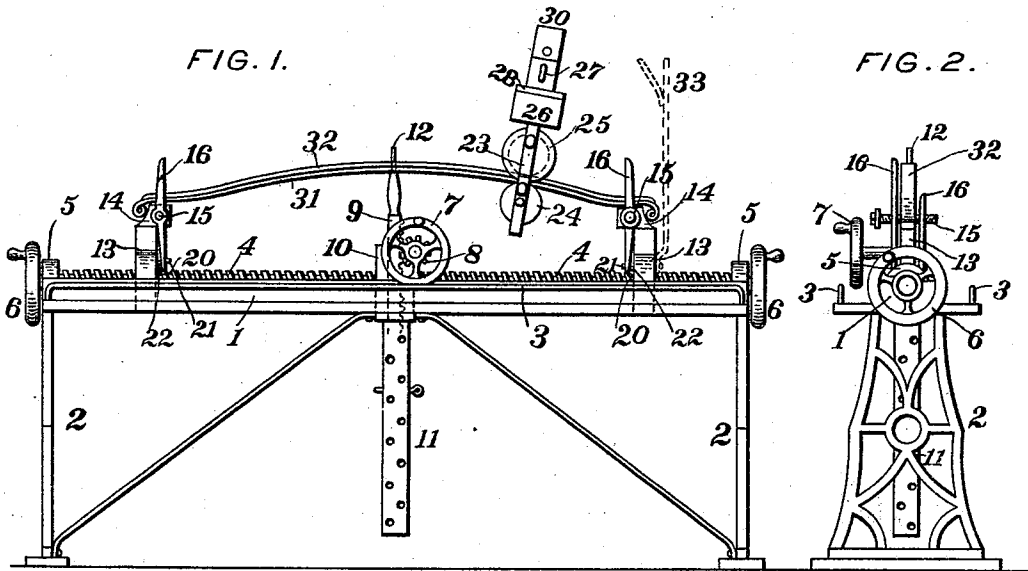

Witnesses  
*Jas. Smith.*  
*Jos. C. Johnson*

Inventors:  
*Wm. Bauer.*  
*Wm. J. Bauer.*  
By *Edwin Guthrie.*  
Attorney

# UNITED STATES PATENT OFFICE.

WILLIAM BAUER AND WILLIAM JOHN BAUER, OF ALLEGHENY,  
PENNSYLVANIA.

## SPRING-BENDING MACHINE.

SPECIFICATION forming part of Letters Patent No. 525,326, dated September 4, 1894.

Application filed April 30, 1894. Serial No. 509,537. (No model.)

*To all whom it may concern:*

Be it known that we, WILLIAM BAUER and WILLIAM JOHN BAUER, citizens of the United States residing at Allegheny, in the county of Allegheny and State of Pennsylvania, have invented certain new and useful Improvements in Spring-Bending Machines; and we do declare the following to be a full, clear, and exact description of the invention, such as will enable others skilled in the art to which it appertains to make and use the same, reference being had to the accompanying drawings, and to the figures of reference marked thereon, which form a part of this specification.

This invention relates to machines for forming the leaves of bow springs for use between the bodies or platforms and the running gear of vehicles.

It has for its object the more rapid handling of the work together with a material decrease in the amount of physical labor demanded of the operative.

Springs of this character usually consist of a base bow and any number of superimposed leaves. The base bow, provided at its ends with eyes through which pass bolts uniting the upper and lower halves of a completed vehicle spring, is the longest piece and each added leaf is somewhat less in length. These said leaves are bent into the form desired while hot and made to follow a cold pattern by being placed thereupon, the extremities pressed down and fastened, and the entire length of the leaf along the pattern pinched at short intervals by clamping tongs in the hands of the operatives. In order to insure absolute correspondence between pattern and leaf, the pinching process is repeated several times throughout the whole length and upon both sides of the piece operated upon. The physical strains and incidental jarring movements of the body unavoidable in the practice of this method are severe upon the workman, and he is unable to produce as many formed leaves as should result from the given expenditure of time and manual labor.

The essential features in our invention for compelling coincidence between hot leaf and cold pattern are as follows: A machine bed supported upon legs or standards of ordinary

construction; two longitudinal screw rods each reaching from an end to a point near the middle of the bed and each screw suitably journaled at its extremities, and possessing, immediately beyond the ends of said bed, hand wheels by which each screw may be separately operated. The machine bed is slotted lengthwise and within the said slot and upon the upper planed surface of said bed, carriages are moved toward and from the middle. Tongs borne upon these carriages, with handles extending upon opposite sides of the bed, are used to clamp the ends of the leaf and the pattern the middle of which is supported at any desired distance above the said ends by an upright rack, raised and lowered by a hand wheel and pinion and limited in its descent by a pin thrust through orifices in the sides of the boxings inclosing said rack. The hot leaf and cold pattern are pressed together by two connected pairs of roll bearing tongs which are moved over the length of the spring in the hands of workmen upon opposite sides of the machine, securing conformity with a minimum of labor. The details of the mechanism by which we accomplish these results, together with the preferred mode of operating the device are set out below.

In the accompanying drawings like numbers represent like parts in the different views.

Figure 1, is a side view of the machine, the tongs being omitted for the sake of clearness. Fig. 2, is a view of one end of the machine. Fig. 3, is a side view of the roll bearing tongs; Fig. 4, a vertical section on the line  $x-x$  of Fig. 3. Fig. 5, is an end view of one of the carriages showing the end tongs attached. Fig. 6, is a side view of the carriage and tongs, and Fig. 7, is a front view of the carriage and tongs showing the righting springs and back stop for the pivoted arms as more fully hereinafter described. Fig. 8, presents a side view of the reversible rack.

1 is the bed of the machine, 2, the supporting legs thereof, 3, rails attached one on each side of the bed as a rest for the movable member of the end tongs when dropped by the operative, obviating a long downward reach in recovering the same.

4, 4, are the main screws working longitudinally and having journals at their extremities for which the bearings are provided at 5, 5, and in the box, 10, at the middle of the bed. 6, 6, are the hand wheels rotating the said screws separately.

7, is a hand wheel upon a shaft which bears at its inner end the pinion, 8, engaging the upright movable rack, 9. Said rack passes through the boxing, 10, occupying a position midway between the ends of the machine bed, and enters the depending box, 11. Said box, 11, is pierced at different heights through each of its four sides with holes for the reception of the pin limiting the descent of the rack within the said box.

The upper portion of the rack, 9, may or may not be detachable, and is flattened to permit the passage of the roll bearing tongs as more fully explained below. The width of said upper portion of 9 is presented as in Fig. 1, parallel with the length of the machine. The upper extremity of said rack, 9, is formed into a cylindrical pin, 12, to be passed through bolt holes in the pattern and spring leaves until arrested by the shoulder upon the part at 9. The height of the middle of the pattern above its ends is maintained in this way.

13, 13, are castings having shoulders and depending lugs, also the extended arms as shown in Figs. 5 and 7, and the threaded orifices, 19, to engage the main screws, 4. The depending lugs of said castings occupy the longitudinal slots of the machine bed and we may find it advisable to use cross pieces bolted to the bottom of said castings to prevent wobbling. It will be seen that these carriage castings are capable of independent travel in the said slots.

14, 14, are blocks of metal let into the upper surfaces of the castings, 13, and held steadily in position by ordinary set screws through the inner faces of said castings. The upper corner of block, 14, toward the end of the machine is usually cut away in a curve to give place to the eye formed at each end of the base plate of a spring.

15, 15, are headed screws passing through smooth bores in the blocks, 14, and one half of the threads of each screw are right hand, the other half left hand threads. At the middle of each of these screws is a short unthreaded portion of less diameter than the threaded parts, and closely above and below this unthreaded portion bolts or pins are passed occupying holes in the said blocks, 14. The distance between the said pins being less than the diameter of the threaded parts of the screw, the same may be turned without loss of position. Upon each side of block, 14, and threaded upon screw, 15, are the pivoted arms, 16. These arms are of similar shape, but that next the tongs upon either carriage is considerably the shorter, enabling the inner section of said tongs to pass above it when the outer end of the movable member, 17, is dropped upon the rail, 3.

17, is the movable member of the end tongs pivoted to the arm of the casting, 13, to which is also attached the fixed member, 18. 17 and 18 are adapted to be held together by a ring and notches as shown in Fig. 5, this being the commonest and simplest means.

19, is the threaded orifice to engage the main screw, 4, as above set out.

20, 20, are springs to return the pivoted arms, 16, to the perpendicular. Said springs are bolted to the inner face of the casting below and between the pivoted arms and are connected at their upper extremities by the cross piece, 21.

22, is a cross piece upon the inner face of the casting, 13, and limits the backward motion of the lower ends of the said pivoted arms.

23, 23, are the roll bearing tongs as best shown in Fig. 3.

The lower rolls, 24, are without flanges while the upper rolls, 25, are provided with them. These rolls are countersunk upon their inner disks enabling the heads of the pins upon which they revolve to be kept flush with said inner surface of said rolls. Provision is made in the construction of these tongs for the passage of the flange upon the upper rolls when

upper and lower rolls are brought very near together. 26, 26, are slotted plates bolted together at the middle point upon an intermediate block, 29, and connected at the ends by upright pieces threaded for the insertion of thumb screws, 27, 27. The upward extending arms of the elbows of said tongs bearing the flanged rolls, 25, terminate in the channeled blocks, 28, to which they are pivotally attached by pins passing through holes in said blocks. The ends of said pins travel the slots in the plates 26, and we may prefer to extend the blocks, 28, so as to occupy and travel the said slots with the view of increased steadiness of action in this part of our invention.

Through an upward extension of the blocks, 28, the unthreaded ends of screws, 27, 27, pass, and pins are driven through said ends, which, aided by the shoulders of the screws upon the opposite sides of the upward extensions of the blocks, 28, enables each of said blocks to be moved toward and from the uniting block, 29, thus separating the sets of rolls and tongs or causing them to approach each other.

It is obvious that the use of a screw possessing right and left hand threads, as characteristic of screws, 15, would permit the roll bearing tongs to be moved toward or from each other by turning one handle and screw only, and we may decide to adopt this modification.

30 is a stout wrought iron or steel strap or bridge piece, riveted to the uprights shown in Fig. 3, for purposes of rigidity and strength.

31, is the base bow of a spring and 32 the leaf to be placed next above and formed upon it.

The customary mode of operation is substantially as follows: The leg, 17, of the end tongs has been dropped upon the rail, 3, rais-

ing the inner extension thereof over and above the shorter arm, 16, and out of the way of the base leaf or pattern, 31, which is placed upon the machine so that pin, 12, passes through the middle bolt hole of said pattern and the ends thereof rest upon the blocks, 14, between the arms, 16, upon the carriages at the ends of the bed; rack, 9, being raised so as to properly support the bend of the pattern at its highest point. In certain classes of springs the holes are punched but part way through. This results upon the upper side of the leaf in a low rounded protuberance which enters the hole in the leaf above it, thus retaining it in proper position. For such cases the lower end of the rack, 9, is provided with a short nose to fit these shallow recesses, and the rack is adapted to be taken out and reversed. When the said rack has been raised to the proper height supporting the pattern leaf, a pin is passed beneath it through the holes in the sides of the box, 11, and a firm base is attained to resist any downward pressure from or weight of the roll tongs and attachments. If the leaves extend equal distances from the bolt holes through them, the carriages are stopped upon the bed at corresponding points from the middle thereof. If this is not the case the position of each carriage is modified accordingly. The leaves to be bent upon the pattern are already punched with the bolt holes and are drawn hot from the furnace. An end is passed between the roll tongs (which hang from a rest upon one of the carriages, as at 33), and over the pin, 12. The free end is then quickly bent down and both ends are clamped by extensions of the end tongs passing between the pivoted arms, 16, from the side farthest from the middle of the machine. The arms, 16, having been set at the proper distance apart act as guides for the leaves and the roll tongs being also set for the particular work in hand are closed upon opposite edges of the pattern and leaf, occupying a narrow width only thereof, and moved from end to end of the spring as often as may be required to establish similarity of curvature. The operation of these roll tongs is of the simplest description and it may be carried out by two boys or unskilled workmen directed by a competent fitter. When the roll tongs reach either end of the spring it will be noticed that the arms, 16, yield to the pressure and swing back upon the pivot permitting the application of the clamping rolls to the extreme ends of the particular leaf treated. The construction of the inner bent fingers of the end tongs is such that the rolls pass upon both sides thereof and the slotted plates, 26, move over said fingers without interference, as shown in the drawings.

There is a concluding step in the process. The ends of any leaf are considerably less in thickness than the mid-section and consequently cool more rapidly. It is found that the curvature given the heated leaf up to this stage of the work is not sufficient to com-

pel the ends to lie closely together when a spring is in use; it is the practice, therefore, to raise rack, 9, by hand wheel and pinion giving each leaf a curve of somewhat less radius than its pattern. This final bend compels, when all the leaves of a spring are bolted or otherwise fastened together, an intimate bearing of the ends of one leaf upon the upper surface of that immediately beneath it. When all the leaves of a stated length have been bent to the curve required, one of them is used for the cold pattern and the next series manipulated in the manner described.

Having thus described our invention in detail, what we claim, and desire to protect by Letters Patent, is—

1. In a spring bending machine the combination of a suitably supported bed, slotted lengthwise, with the boxing located at the middle of said bed, said boxing provided with a depending portion having its opposite sides perforated with corresponding orifices for the insertion of a pin, and each pair of corresponding orifices at different distances, vertically measured, from the plane of the machine bed, a reversible rack sliding within said boxes and adapted to be raised or lowered by a hand wheel and pinion fast upon a cross shaft journaled in said upper box, the whole constructed and arranged substantially as shown and described for the purpose set forth.

2. In a spring bending machine, a reversible sliding rack adapted to be operated by a pinion and provided at one end with a flattened portion terminating in a cylindrical pin, said rack having at the other end a short rounded projection, the whole constructed as shown and described for the purposes set forth.

3. In a spring bending machine, a suitably supported bed, slotted lengthwise, in combination with the two screw-rods lying partly within said slots, each screw-rod provided with a hand wheel and journaled at the end and near the middle of the machine bed, the carriages bearing clamping tongs and traveling said slots and sliding upon the upper surface of said machine bed, said carriages having threaded orifices for the engagement of said screw-rods by which they are independently moved toward or from each other, and the adjustable and reversible rack located midway between the ends of said bed, the whole constructed and arranged substantially as shown and described for the purpose of holding a former and spring leaf together and in proper position while being operated upon as specified.

4. In a spring bending machine, the combination of a suitably supported bed, 1, slotted lengthwise and provided with rails, 3, with the screw-rods, 4, journaled at the ends and middle of said bed and having hand wheels, 6; the upper box, 10, fixed at the middle of the machine bed and supporting the lower box, 11, the opposite sides of which possess a number of corresponding perforations for the in-

sertion of a pin, and each pair of opposite and corresponding perforations situated at different distances from the plane of the machine bed; the reversible sliding rack, 9, enclosed within said boxes and operated by hand wheel, 7, and pinion, 8, fast upon a cross shaft journaled in the said box, 10; and the carriages, 13, traveling within said slots and upon the machine bed and adapted to be moved independently toward or from the middle by said screw-rods upon which they are threaded, the whole constructed and arranged substantially as shown and described for the purposes specified.

5. In a spring bending machine, the carriage casting having the threaded orifice and extended arm affording a pivot support for a pair of clamping tongs, in combination with the entering block, right and left hand screw, and pivoted arms with the righting springs and back stop, the whole constructed and arranged substantially as shown and described.

6. In a spring bending machine, a sliding carriage consisting of a main casting, 13, provided with an extended arm and a threaded orifice, 19, in combination with the entering block, 14, right and left hand screw, 15, long and short arms, 16, threaded upon said screw, the fixed leg, 18, of the end-tongs, and pivoted member, 17, of said tongs so bent as to pass between the said arms, 16, and clamp the former and leaf of a spring near their ends and upon said block, 14, the whole constructed and arranged substantially as shown and described.

7. In a spring bending machine, a pair of pinching tongs having the ends of the two members, on the same side and at equal distances from the pivot, bent away from each other, approximately at right angles with said members, the perpendicular sections thus formed provided with fixed, outwardly projecting headed pins, upon which rotate roll-

ers adapted to exert pressure near the edge of a former and spring leaf and to be moved under said pressure from end to end of said leaf and former substantially as shown and described for the purpose specified.

8. In a spring bending machine, compound pinching tongs, consisting of two pairs of pivotally connected tongs, each pair having the ends of the two members, on the same side and at equal distances from the pivot, bent away from each other, approximately at right angles with said members, the perpendicular sections thus formed provided with fixed, outwardly projecting headed pins, upon which rotate rollers, and the ends of the upper perpendicular sections of each pair of tongs being pivoted to channeled blocks which slide within and upon slotted cross-pieces forming the base of a framework, said sliding blocks being movable toward or from the middle of said slotted cross-pieces by thumbscrews threaded in the opposite sides of said framework for the purpose of varying the space between said pairs of roll bearing tongs, the whole constructed and arranged substantially as shown and described.

9. In a spring bending machine, the two connected pairs of tongs, 23, in combination with the flanged rolls, 25, the plain rolls 24, slotted plates, 26, the thumb screws, 27, the channeled blocks, 28, the block, 29, connecting the middle of the slotted plates, and the uprights and strengthening bridge, 30, all constructed and arranged substantially as shown and described for the purposes set forth.

In testimony whereof we affix our signatures in presence of two witnesses.

WILLIAM BAUER.  
WILLIAM JOHN BAUER.

Witnesses:

M. AMBACHER,  
EDWIN H. WENDELL.