

(No Model.)

2 Sheets—Sheet 1.

I. G. JONES.
GRAIN WEIGHING MACHINE.

No. 525,080.

Patented Aug. 28, 1894.

FIG. 1.

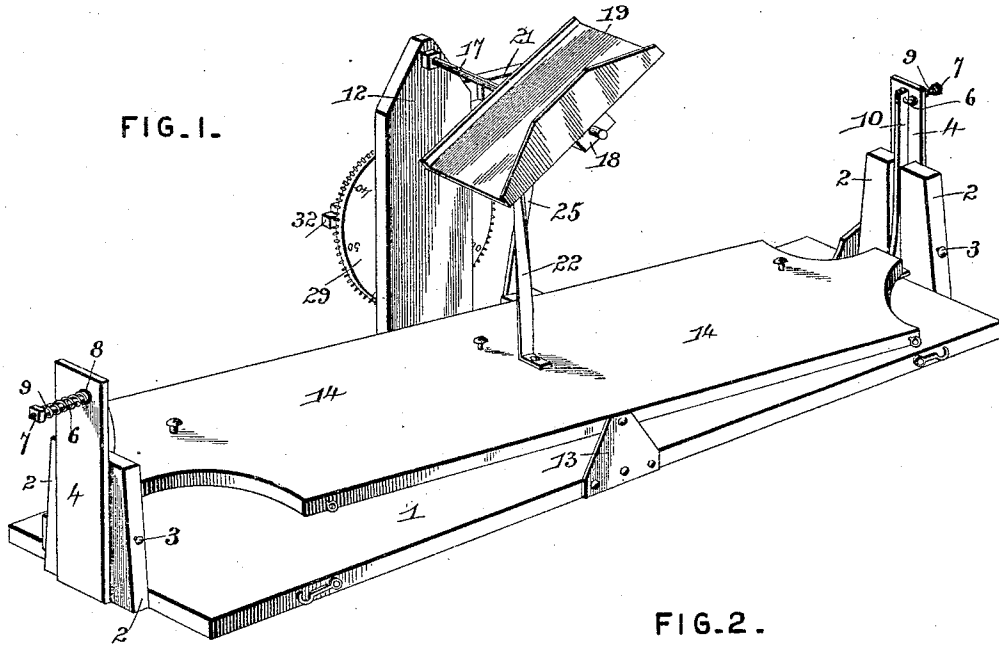
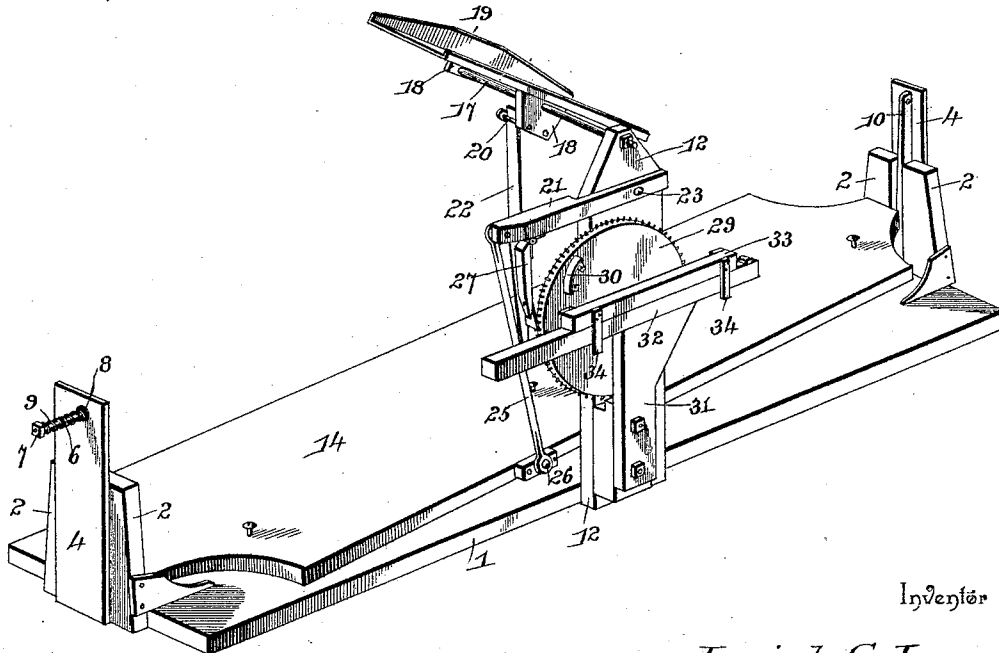

FIG. 2.



Inventor

Isaiah G. Jones

Witnesses:

Jas. K. McCutchan
W. S. Duwall.

By his Attorneys.

C. A. Snow & Co.

(No Model.)

2 Sheets—Sheet 2.

I. G. JONES.
GRAIN WEIGHING MACHINE.

No. 525,080.

Patented Aug. 28, 1894.

FIG. 3.

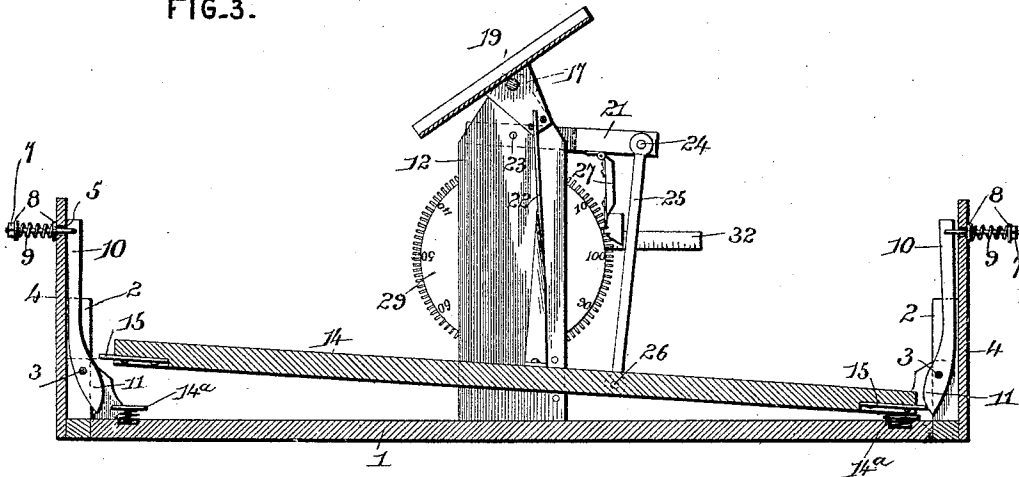

FIG. 5.

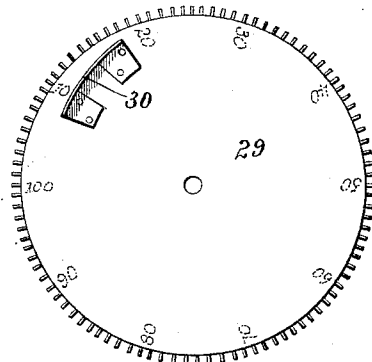

FIG. 4.

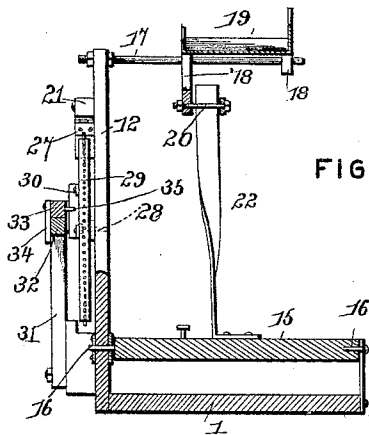
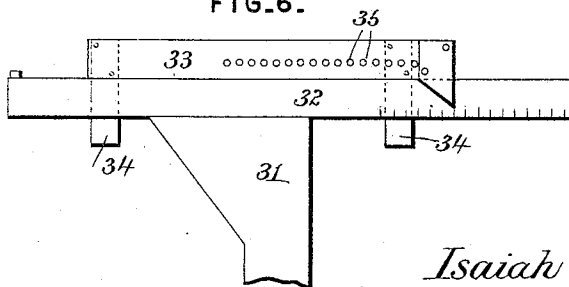

FIG. 6.



Inventor

Isaiah G. Jones

By his Attorneys.

Witnesses

Jas. H. McLaughlin
W. S. Duwall

C. A. Snow & Co.

UNITED STATES PATENT OFFICE.

ISAIAH G. JONES, OF VINCENTOWN, NEW JERSEY.

GRAIN-WEIGHING MACHINE.

SPECIFICATION forming part of Letters Patent No. 525,080, dated August 28, 1894.

Application filed October 11, 1893. Serial No. 487,840. (No model.)

To all whom it may concern:

Be it known that I, ISAIAH G. JONES, a citizen of the United States, residing at Vincenttown, in the county of Burlington and State of New Jersey, have invented a new and useful Grain-Scale, of which the following is a specification.

My invention relates to improvements in grain scales; the objects in view being to produce a cheap and simple machine adapted to be used in connection with any ordinary thrashing-machine, and to automatically weigh and deliver to suitable receptacles placed thereon the grain as the same passes from the thrasher; to provide for a regulation of the scale, whereby the same may be made to weigh different quantities of grain; and finally to provide for a register designed to be operated by the machine and to accurately register the number of bushels or fractions thereof that are delivered by the machine to the bags or other receptacles placed thereon.

Other objects and advantages of the invention will appear in the following description and the novel features thereof will be particularly pointed out in the claims.

Referring to the drawings:—Figure 1 is a perspective view of a grain scale embodying my invention. Fig. 2 is a rear perspective. Fig. 3 is a vertical longitudinal sectional view. Fig. 4 is a transverse vertical view. Fig. 5 is a detail in elevation of the registering wheel. Fig. 6 is a transverse sectional view through the machine, the line of section being between the registering wheel and the registering-bar.

Like numerals of reference indicate like parts in all the figures of the drawings.

In carrying out my invention I employ an oblong base 1 of any desired length and width, and affix to the opposite ends thereof and at the longitudinal center vertical standards 2. These standards are bifurcated or slotted vertically through the upper ends to the base 1, and a bearing-pin 3 is passed transversely through each of the bifurcated or slotted standards. Secured to the outer sides of these standards and extending across the slot or bifurcation thereof and projecting above the standards are extensions 4, whose upper ends are provided with perforations 5 through

which eye-bolts 6 pass. The outer ends of these eye-bolts have arranged thereon regulating-nuts 7, adjacent to which and the extensions 4 washers 8 are located. Interposed between the washers and located upon each of the aforesaid eye-bolts is a coiled spring 9, whose tension may be regulated through the nuts mentioned.

Upon each of the bearing pins 3 there is pivoted a curved latch-lever 10, the lower end being provided with a convexed cam-face 11 and the upper end perforated and connected with the eye-bolt at that end of the machine, so that the spring exerts a tendency to draw the upper end of the lever outward.

To the rear edge of the base there is affixed a vertical standard 12, and to the front edge of the base directly opposite the standard 12 a shorter bearing-standard 13 is affixed. Between these standards is located the oscillating platform 14 of the machine, the ends of the platform terminating short of the standards 2 at the ends of the base and having secured thereto and projecting slightly therebeyond the metal wear-plates 15, under which extend the convexed portions or cam-faces 11 of the levers and also spring buffers 14^a. Journal bolts 16 extend through the bearing standards 12 and 13 and into the edges of the oscillating platform, whereby the latter is supported a short distance above the base.

Extending from the upper end of the rear standard 12 across and above the platform 14 is a transverse shaft 17, and the same passes through a pair of bearing-ears 18 located upon the under side of a tilting-trough 19. The rear bearing-ear is longer than the front one and is provided upon its front face with a pair of forwardly extending pins 20. A vertical arm 22 is secured to the center of the platform 14 and extends upwardly between the pins 20. Pivoted, as at 23, to the rear side of this standard 12, is an arm 21, and pivoted to the outer end of this arm, as at 24, is a connecting-rod 25, the lower end of which is pivoted, as at 26, to the rear edge of the tilting or oscillating platform 14. Pivoted to the under side of the arm 21 near the free end thereof is a gravity pawl 27. A stub axle 28 extends from the back of the standard 12 below the arm 21, and upon this axle

there is loosely mounted for rotation a register-wheel 29, whose periphery is arranged in the path of the pawl 27 as the same is raised and lowered in a manner hereinafter described and which is divided into a hundred degrees through the medium of the projecting pins or teeth, as shown. The wheel is further provided upon its rear side with an eccentrically disposed flange 30.

10 Projecting rearwardly and upwardly from the rear standard 12 is a back standard 31 which terminates opposite the wheel 29, and has mounted upon its upper end a horizontal scale-bar 32. The front face of this bar is graduated, or in other words, carries a scale 15 designed to register the tens. Mounted for sliding on this scale-bar is a movable register-bar 33 provided at its opposite faces with depending keepers 34 which maintain the bar 20 33 in position upon the register-bar. The front face of the register-bar 33 is provided with a series of teeth 35 and the same are arranged in the path of the tangential flange 30. This completes the construction of the 25 machine which as will be obvious is extremely simple. In operation the tension of the springs having been adjusted so that, for instance, it will require just a bushel of grain to depress either end of the platform 14, the machine is 30 placed under the discharge end of a thrashing machine, the tilting-trough being in such position as to receive grain as the same is discharged therefrom. The operator places a bag or other receptacle upon the end of the 35 platform, and the grain passing over the thrashing-machine to the trough is delivered by the latter into said bag. When a bushel of grain, for instance, has been delivered into the bag the weight of the grain causes that 40 end of the platform 14 upon which the bag is located to become depressed, the metal-plate at the end of said platform riding over the convexed face of the lever at that end of the machine. This depression of the end of the 45 platform causes the arm 22 to vibrate and thus tilt the trough 19 in a reverse direction to the platform so that the grain is then delivered from the opposite end of the trough into a receptacle or bag awaiting the same.

50 Thus it will be seen that as one bag is being filled another bag may be emptied and placed upon the platform to receive the next discharge of grain.

The oscillations of the platform 14 through 55 the medium of the connecting-rod raises and lowers the arm 21 and with it the pawl 27 so that at each raising of the arm the pawl engages with a succeeding tooth of the registering-wheel, and at each depression said wheel 60 is moved the distance of one tooth. By the time that the wheel has traveled completely around it will have registered one hundred bushels of grain, and at this time the eccentric flange on the rear side of the wheel engages with a tooth on the register-bar and being tangential in its disposition will force said 65 bar along on the scale-bar one graduation

which will thus register one hundred bushels. Thus it will be seen that while the wheel registers the fractions of a hundred the scale-bar will register the hundreds. 70

I do not limit my invention to the precise details of construction herein shown and described, but hold that I may vary the same to any degree and extent within the knowledge 75 of the skilled mechanic.

Having described my invention, what I claim is—

1. In a grain-scale, the combination with the base, and the standards at the opposite 80 ends thereof, of an oscillating platform pivoted above the base between the standards, levers pivoted to the standards and having cam faces engaged by the ends of the platform, springs for yieldingly pressing the levers 85 inward in the path of the platform, a tilting-trough arranged above the platform, and devices between the platform and trough for operating the latter at each operation of the platform, substantially as specified. 90

2. In a grain scale, the combination with a platform, standards at the opposite ends thereof provided with extensions having perforations, levers pivoted in the standards and having lower convexed ends, eye-bolts arranged 95 in perforations in the extensions, regulating nuts arranged on the eye-bolts, springs interposed between the regulating nuts and the extensions, of opposite bearings at the center of the base, a tilting platform journaled between said bearings and between the 100 standards and adapted at its ends to bear upon the convexed faces of the levers, a tilting trough arranged above the platform, and an arm extending from the platform and 105 loosely engaging with said trough, substantially as specified.

3. In a grain scale, the combination with a base, a tilting platform, a tilting-trough, and connecting devices between the same and 110 platform, of a standard rising from the base, an arm pivoted to the standard, a connecting-rod between the arm and the platform, a pawl carried by the arm, and a register-wheel carried by the standard and engaged by the pawl, 115 substantially as specified.

4. In a grain scale, the combination with a base, a tilting platform, a tilting trough, and connecting devices between the same and 120 platform, of a standard rising from the base, an arm pivoted to the standard, a connecting-rod between the arm and the platform, a pawl carried by the arm, a register-wheel carried by the standard and engaged by the pawl, a 125 scale-bar arranged at the side of the wheel, a register-bar mounted upon the scale-bar, and devices carried by the register-wheel for moving the register-bar at each rotation of the wheel, substantially as specified.

5. In a grain scale, the combination with the base, the tilting platform, of a superimposed tilting-trough, connections between the same and platform, a rear standard, a toothed 130 register-wheel journaled at the rear side of

the standard, an arm pivoted to the standard, a connecting-rod between the outer end of the arm and the platform, a pawl pivoted to the arm and engaging the teeth of the wheel, 5 an eccentrically disposed flange arranged on the rear side of the wheel, a standard extending rearward and upward from the first mentioned standard and carrying a horizontal scale-bar, and a registering-bar arranged for 10 movement upon the scale-bar and having a series of teeth adapted to be engaged by the aforesaid flange at each rotation of the registering-wheel, substantially as specified.

6. In a grain-scale, the combination with 15 the base, and the standards at the opposite ends thereof, of an oscillating platform pivoted above the base between the standards,

levers pivoted to the standards and having cam faces engaged by the ends of the platform, springs for yieldingly pressing the le- 20 vers inward in the path of the platform, a tilting-trough arranged above the platform, devices between the platform and trough for operating the latter at each operation of the platform, and spring-buffers 14^a applied to 25 the base adjacent to the outer ends of the platform, substantially as specified.

In testimony that I claim the foregoing as my own I have hereto affixed my signature in the presence of two witnesses.

ISAIAH G. JONES.

Witnesses:

FRANK S. HILLIARD,
JOHN ROSS.