

12 **EUROPEAN PATENT APPLICATION**

21 Application number: 81110227.6

51 Int. Cl.³: **F 28 F 25/08**
F 28 C 1/00

22 Date of filing: 08.12.81

30 Priority: 08.12.80 ZA 807676
30.03.81 ZA 812114

43 Date of publication of application:
16.06.82 Bulletin 82/24

84 Designated Contracting States:
AT BE CH DE FR GB IT LI LU NL SE

71 Applicant: **WLPV HOLDINGS (PROPRIETARY) LIMITED**
103 Simmonds Street Braamfontein
Johannesburg Transvaal(ZA)

72 Inventor: **Bosman, Peter Barry**
101 Boundary Lane, Parkmore
Sandton, Transvaal Province(ZA)

74 Representative: **Hulse, Thomas Arnold et al,**
Hulse & Co. Cavendish Buildings West Street
Sheffield S1 1ZZ(GB)

54 **A pack for cooling towers.**

57 The invention relates to a film pack for use in wet cooling towers in which a heated liquid, forming a film on sheets forming the pack, is cooled evaporatively by natural or induced air flow through the pack. The pack of the invention is particularly made up of a plurality of asbestos cement spaced apart sheet elements having intermediate elements disposed between them. The intermediate elements serve to increase the effective surface area of the pack for a liquid film to form on and can also serve as spacers for spacing apart the asbestos cement sheet elements.

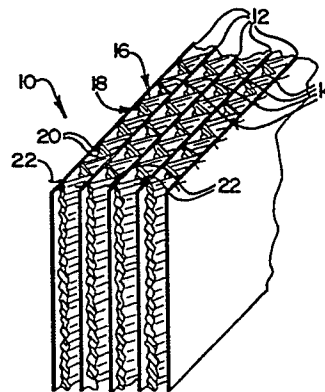

FIG. 1

THIS INVENTION relates to a pack for cooling towers. In particular the invention relates to a film pack for use in cooling towers. More particularly the invention relates to such a film pack for use in wet cooling towers in which a heated liquid is cooled evaporatively by natural or induced air flow.

Film packs known to the applicant comprise a pack or stack of spaced apart sheet elements which can be located substantially vertically within a wet cooling tower and upon which a liquid film of heated liquid can form which can flow under gravity down these elements along the opposing surfaces thereof. This liquid film can thus be cooled by air flowing in an opposite direction to the liquid through the spaces defined between adjacent spaced apart sheet elements. The sheet elements may be planar or corrugated, the latter sheets providing an extended contact area for cooling purposes without using additional space.

According to the invention there is provided a film pack which includes a plurality of substantially parallel at least partially spaced apart asbestos cement sheet elements; and at least one sheet-like intermediate element of a plastics material disposed in a space defined between two adjacent sheet elements.

The film pack may include sheet-like intermediate elements disposed in spaces defined between all adjacent sheet elements. The intermediate elements may be spacer elements for spacing apart adjacent sheet elements. For this purpose the intermediate elements may be substantially rigid.

Preferably the intermediate elements may be in the form of corrugated sheets. In particular the intermediate elements may define primary corrugations, the amplitude of the primary corrugations determining the spacing between adjacent sheet elements. More particularly the primary corrugations may be vertically disposed in the operative configuration of the film pack. Also, in a modified embodiment, the primary corrugations may define corrugated paths with respect to the median plane of the intermediate elements.

Furthermore the intermediate elements may define auxiliary corrugations of smaller amplitude than the primary corrugations and disposed angularly with respect to the primary corrugations. The primary and auxiliary corrugations may be

mutually orthogonal to one another.

Intermediate elements having primary and auxiliary corrugations as above defined are substantially rigid, particularly in a direction perpendicular to the plane of the plastics sheet, so that the spacing between adjacent sheet elements can be rigidly fixed thereby.

Also with the primary corrugations vertically disposed in the operative configuration of the film pack air flow resistance in a vertical direction through the film pack is thereby minimised as far as possible. It will also be understood that due to the auxiliary corrugations, point contacts are provided between the sheet elements and intermediate elements so that air and liquid flow between adjacent primary corrugations is possible and in this way ensuring that the air and liquid flow through various regions of the film pack is substantially consistent. Apices are thus defined by the corrugations which contact the sheet elements.

The angle of the primary corrugations where each intermediate element intersects its median plane may be between 30° and 60° and may preferably be 45° . It will be understood that this angle can determine and control the spacing between adjacent sheet elements.

In one configuration the sheet elements may be planar. In this configuration the film pack may include

securing means for securing the sheet elements and intermediate elements together. The securing means may be wire elements which can clip onto the sheet elements and intermediate elements to hold them together.

Alternatively the securing means may be plastics securing elements which can simultaneously engage a sheet element and an adjacent intermediate element to hold them together. In this configuration the securing elements may define at least one clip formation which can clip onto a sheet element and an adjacent intermediate element to hold them together. More particularly the securing elements may define at least two clip formations which can clip onto sheet elements and their adjacent intermediate elements.

Each clip formation defined by a securing element may define two opposing legs which can simultaneously clip onto a sheet element and an adjacent intermediate element to hold them together. The opposing legs may clip onto an edge region of a sheet element and an adjacent intermediate element. Also, the opposing legs may project from a base portion which is common to at least two pairs of opposing legs, all the legs lying in the same plane.

Conveniently the opposing legs may define edge regions complimentary to the regions of the sheet elements or intermediate elements which they engage to enhance such engagement. Alternatively or, in addition at least one leg of

a pair of opposing legs may define a serrated edge region to enhance engagement with a sheet element or intermediate element which it engages for holding together a sheet element and an intermediate element.

Generally the securing means may secure together the sheet elements and intermediate elements on at least two sides of the pack so as to hold an entire pack together.

In a second configuration the sheet elements may be corrugated. In this configuration the intermediate elements may include additional locating corrugations complimentary to the corrugations of the sheet elements so that the sheet elements and intermediate elements nest within one another. The locating corrugations of the intermediate elements may be mutually orthogonal with respect to the primary corrugations and may be of larger amplitude than the auxiliary corrugations. As such the sheet elements and the intermediate elements may be located with respect to one another by the location of the outer sheet elements.

In still a further configuration the film pack may have sheet elements that are corrugated, the corrugations being vertically disposed in the operative configuration of the film pack. In this configuration adjacent sheet elements may be arranged so that the peaks of the corrugations of one element abut the valleys of the corrugations of an adjacent element, thereby defining a series of spaces between adjacent elements

within which intermediate elements are disposed.

Alternatively, in this configuration corrugated sheet elements may abut additional planar sheet elements disposed between them, spaces being defined between the corrugated and planar sheet elements within which intermediate elements are disposed.

As before, in this configuration the intermediate elements may be in the form of corrugated sheets. More particularly the intermediate elements may define primary corrugations which are adapted so that the intermediate elements fit into the spaces defined between the sheet elements abutting both such sheet elements. In addition the intermediate elements may define auxiliary corrugations of smaller amplitude than the primary corrugation and mutually orthogonal therewith.

The film pack in accordance with the invention may further include end spacers disposed between the sheet elements at opposite side ends of the pack. Also the film pack may be adapted to be supported on a support structure therefor in a cooling tower.

The invention further extends to a cooling tower including a film pack in accordance with the invention. Still further, the invention extends to an asbestos cement sheet element for a film pack in accordance with the invention and to a sheet-like intermediate element and a securing means for such

a film pack.

The intermediate elements and the securing elements above defined may both be of a PVC material. The securing elements may alternatively be of polyethylene or polypropylene.

By providing film packs having intermediate elements in the form of plastics sheets the surface area upon which liquid films can be formed for cooling of such liquids is increased and the efficiency of such packs is thus higher than for conventional packs.

To further increase the surface area the intermediate elements may additionally be dimpled. The configuration of such dimples and/or of the corrugations may be such that the resistance to air flow through a film pack is kept to a minimum. It will be understood that the provision of the corrugations and dimples add to the extension of the surface, upon which a liquid film can form, over and above the surface of a planar sheet element.

The invention is now described, by way of examples, with reference to the accompanying drawings, in which :

Figure 1 shows a three-dimensional view of a first embodiment of a part of a film pack in accordance with the invention;

Figure 1A shows a three-dimensional view of a modified intermediate element for the film pack of Figure 1;

Figure 2 shows a cross-sectional end view of a portion of the pack shown in Figure 1;

Figure 3 shows a three-dimensional view of a second embodiment of a part of a film pack in accordance with the invention;

Figure 4 shows a three dimensional view of a part of a third embodiment of a film pack in accordance with the invention;

Figure 5 shows a side view of a securing element for the pack shown in Figure 4;

Figure 6 shows an end view of the securing element of Figure 5;

Figure 7 shows an enlarged cross-sectional end view of a portion of the pack of Figure 4 indicating the use of the securing element of Figure 5;

Figure 8 shows a plan view of a fourth embodiment of a film pack in accordance with the invention;

Figure 9 shows a three dimensional view of an intermediate element for the film pack of Figure 8;

Figure 10 shows a three-dimensional view of a fifth embodiment of a film pack in accordance with the invention;

Figure 11 shows a plan view of the film pack of Figure 10; and

Figure 12 shows a three dimensional view of a mode of installation of a film pack, in accordance with the invention, in a cooling tower.

Referring to the drawings and, in particular, to

Figures 1, 1A and 2, a first embodiment of a film pack for cooling towers, in accordance with the invention, is generally indicated by the reference numeral 10. The film pack 10 includes a plurality of planar asbestos cement sheet elements 12 spaced apart from one another by plastics sheet intermediate elements 14.

In its operative configuration as shown the sheet elements 12 are substantially vertically disposed whereas the intermediate elements 14 are provided with primary corrugations 16, which are also vertically disposed, and the amplitude of which determines the spacing between adjacent sheet elements 12.

The intermediate elements 14 are further provided with auxiliary corrugations 18 which are disposed orthogonally with respect to the primary corrugations 16 and which have a substantially smaller amplitude than the primary corrugations 16. Having primary corrugations 16 and auxiliary corrugations 18 the intermediate elements are substantially rigid, particularly in a direction perpendicular to the plane of the plastics sheet, intermediate spacer elements 14. Also, as a result of the above corrugations, the intermediate elements define a plurality of apices 20 providing point contact between the sheet elements 12 and intermediate elements 14. The sheet elements 12 and intermediate elements 14 are secured to one another by one or more wire elements 22 which clip onto the sheet elements 12 and intermediate elements 14 as is particularly

BAD ORIGINAL

shown in Figure 2. In this way a rigid film pack of any required size and incorporating any required number of sheet elements 12 can be provided.

Referring particularly to Figure 1A a modified intermediate element 14.1 also includes primary corrugations 16 and auxiliary corrugations 18. However, in this embodiment the primary corrugations define corrugated paths 23 with respect to the median plane of the intermediate elements. This provides additional rigidity to these elements and also prevents any liquid droplets to drop straight through the pack 10 when sprayed onto the pack as is hereinafter described.

In use, the film pack 10 is installed into a cooling tower in the configuration shown. Heated liquid to be cooled, is sprayed onto the film pack 10 and forms a liquid film on the surfaces of the sheet elements 12 and intermediate elements 14.

The film of liquid flows downwardly along the surfaces of the sheet elements 12 and intermediate elements 14 under gravity and is cooled by air flow, which may be natural or induced, flowing vertically upwardly through the spaces defined between the sheet elements 12 by the corrugations 16 of the intermediate elements 14. It will be understood that the auxiliary corrugations 18 will permit some airflow and liquid flow horizontally and in this way it is ensured that the flow of liquid and air is substantially constant throughout the entire film pack 10. It will further be understood that the

Provision of a plastics sheet intermediate element 14 between adjacent sheet elements 12 increases the surface area upon which a liquid film for cooling can form and thus the contact area between liquid and air. The corrugations 16 and 18 of the intermediate elements 14 further increases this area. The efficiency of a pack 10 as described above is thus higher than that of a conventional pack of the same size not having intermediate elements 14, the increased contact area always being measured against increased air flow resistance to provide optimum efficiency.

Referring to Figure 3, showing a second embodiment of a film pack 29, in accordance with the invention, the abovementioned contact area can be further increased by providing corrugated sheet elements 30, corrugations of the sheet elements 30 being horizontally disposed as shown. The sheet elements are again spaced apart by plastics sheet intermediate elements 32. The intermediate elements 32 also have primary corrugations 16 and auxiliary corrugations 18 as described above but are additionally corrugated to be complementary to the corrugated sheets 30 as shown. In addition to providing additional contact area for cooling the construction of a film pack made up of elements 30 and 32 is much simplified since wire elements are not required as these elements locate themselves by means of their complementary corrugations. Only the opposing outer sheet elements of such a film pack need thus be located.



Referring to Figures 1 to 3, the intermediate elements 14, 32 may particularly be of P.V.C. sheeting which may be vacuum formed to define the required corrugations. The angle of the primary corrugations 16 where each intermediate element intersects its median plane clearly determines the spacing between adjacent sheet elements and this angle may thus be varied between, for example, 30° and 60° . Preferably this angle may be 45° . In this latter configuration resistance against air flow, as measured against contact area, through a film pack may be such as to provide optimum efficiency of the pack. For additional contact area it will be understood that the surface of the spacer elements and/or the sheet elements may be dimpled, the design of such dimples, as for that of the corrugations, being such that air flow resistance is minimised as far as is practically possible.

Referring to Figures 4 to 7 of the drawings a third embodiment of a film pack for cooling towers, in accordance with the invention, is generally indicated by the reference numeral 50. As for the film pack 10 above described with reference to Figures 1 and 2, the pack 50 includes a plurality of planar asbestos sheet elements 52 spaced apart from one another by plastics sheet intermediate elements 54.

Furthermore, as before in their operative configuration as shown, the sheet elements 52 are substantially vertically disposed whereas the intermediate elements 54 are provided with primary corrugations 56 which are also vertically disposed, and

the amplitude of which determines the spacing between adjacent sheet elements 52. The intermediate elements are further provided with auxilliary corrugations 58 which are disposed orthogonally with respect to the primary corrugations 56 and which have a substantially smaller amplitude than the primary corrugations 56: Having primary corrugations 56 and auxiliary corrugations 58 the intermediate elements are substantially rigid, particularly in a direction perpendicular to the plane of the plastics sheet, intermediate elements 54. Also, as a result of the above corrugations, the intermediate elements define a plurality of apices 60 providing point contacts between the sheet elements 52 and the intermediate elements 54. The sheet elements 52 and the intermediate elements 54 are secured to one another by a plurality of moulded plastics securing elements 62 which clip onto the sheet elements 52 and the intermediate elements 54 as is particularly shown in Figure 4. In this way a rigid film pack of any required size and incorporating any required number of sheet elements 12 can be provided.

Each securing element 62 comprises two clip formations 64, each clip formation being defined by two opposing legs 62 and 68 respectively, projecting from a common base portion 70. The legs 66 and 68 of each clip formation 64 lie in a common plane and the spacing between the clip formations 64 is equal to the spacing between adjacent sheet elements 52.

As is shown in Figures 4 and 7, the securing elements

62 engage the sheet elements 52 and the intermediate elements 54 in the region of peaks 72 defined by the primary corrugations 56. In particular, each securing element 62 engages simultaneously two sheet elements 52 and the abutting intermediate elements 54 in the above described regions by means of the two clip formations respectively.

Referring particularly to Figure 4, the legs 66 of the clip formations 64 define serrated edges 74 which abut the sheet elements 52 whereas the legs 68 define corrugated edges 76 which abut the intermediate elements 54. The corrugated edges 76 are complimentary to the auxiliary corrugations 58 of the intermediate elements 54 and together with the serrated edges 74 and the proper spacing between the legs 66 and 68, it is ensured that the securing elements clip securely onto the sheets 52 and 54 so that the film pack 50 can be securely held together.

As is clear from Figure 4, the securing elements 62 can clip onto the sheets 52 and 54 in a pre-determined staggered configuration as shown, so that all the sheets 52 and 54 of a film pack 50 can thereby be securely held together. The securing elements 62 are further disposed at opposite ends of the pack 50, only those elements 62 on the top end of the pack being visible in Figure 4.

The securing elements 62 may be of any suitable plastics material and may be formed in any suitable manner such

as by moulding, pressing or the like. Typically, the elements 62 may be of P V C, polyethylene or polypropylene.

Use of the film pack 50 is as described above for the packs 10, 29 with reference to Figures 1 to 3. All the other features of the pack 50 is also equivalent to that described above for the packs 10, 29.

Referring to Figures 8 and 9, a fourth embodiment of a film pack, in accordance with the invention is generally indicated by the reference numeral 80. The film pack 80 includes corrugated asbestos cement sheet elements 82, the corrugations 84 being vertically disposed in the operative configuration of the film pack 80. Adjacent sheet elements 82 are off-set with respect to one another so that the packs of one sheet element 82 abut the valleys of an adjacent sheet element 82 and vice versa. As such, the sheet elements define spaces 86 between them, the spaces 86 having intermediate elements 88 disposed therein as shown. The intermediate elements 88 each define a vertically disposed primary, corrugation and auxiliary corrugations 92, orthogonal to the primary corrugation, an intermediate element as above described being shown in detail in Figure 9. The elements 88 are held in position by planer end regions 94 which are clamped between adjacent sheet elements 82 where they effectively abut.

Figures 10 and 11 show a fifth embodiment of a film pack, indicated by the numeral 100. The film pack 100 again,

includes asbestos cement sheet elements 102, having corrugations 104 that are vertically disposed in the operative configuration of the film pack 100. However, in this configuration additional planar asbestos cement sheet elements 106 are provided which are located between the elements 102, the elements 102 being effectively arranged as the elements 82 described with reference to Figures 8 and 9. Spaces 108 defined between the sheet elements 102 are now divided in half by the elements 106, providing half spaces 108.1 and 108.2.

Each half space 108.1 and 108.2 has an intermediate element 110, disposed therein the elements 110 being equivalent to the element 88 described with reference to Figure 9 and being arranged in the spaces 108 in the configuration as is clearly shown in Figure 11. In this configuration the intermediate elements 110 can be frictionally held in the spaces 108.

Use of the film packs 80 and 100 are again as described above with reference to Figures 1 to 3.

Referring to Figure 12, there is shown a film pack 10 supported in a typical configuration in a cooling tower, As shown the pack 10 is supported upon support beams 120 being horizontally disposed in a cooling tower, upright columns 122 providing for the pack 10 to remain in its upright configuration. Additional spacer members 124, are provided between the sheet elements 12 and thus clearly permit any intermediate elements

BAD ORIGINAL

14 to be removed as may be required. This may be necessary since the effective life of the intermediate elements is significantly shorter than that of the asbestos cement elements 12 and by such replacement the life of a pack 10 can thus be extended.

The spacer members 124 may be of plastics, asbestos cement or concrete and clearly, at least partially, fulfill the function of the intermediate elements 14 insofar as they space apart the sheet elements 12. Such spacer members may clearly also be used for packs 29 and 50 but will not be essential for packs 80 and 100 described above.

It will also be understood that the beams 120 and columns 122 may define a concrete framework in a cooling tower particularly disposed and adapted to support an entire film pack arrangement in such a tower.

Film packs as above described are relatively economic to manufacture and construct and provide superior efficiency as compared with conventional packs not employing intermediate elements of a plastics sheet.

BAD ORIGINAL 

1. A film pack which includes
a plurality of substantially parallel at least partially spaced apart asbestos cement sheet elements; and
at least one sheet-like intermediate element of a plastics material disposed in a space defined between two adjacent sheet elements.
2. A film pack as claimed in Claim 1, which includes sheet-like intermediate elements disposed in spaces defined between all adjacent sheet elements.
3. A film pack as claimed in Claim 1 or Claim 2 in which the intermediate elements are spacer elements for spacing apart adjacent sheet elements.
4. A film pack as claimed in any one of the preceding claims, in which the intermediate elements are substantially rigid.
5. A film pack as claimed in any one of the preceding claims, in which the intermediate elements are in the form of corrugated sheets.
6. A film pack as claimed in Claim 5, in which the intermediate elements define primary corrugations, the amplitude of the primary corrugations determining the spacing between adjacent sheet elements.

7. A film pack as claimed in Claim 6, in which the primary corrugations are substantially vertically disposed in the operative configuration of the film pack.
8. A film pack as claimed in Claim 7, in which the primary corrugations define corrugated paths with respect to the median plane of the intermediate elements.
9. A film pack as claimed in Claim 6, Claim 7 or Claim 8, in which the intermediate elements define auxiliary corrugations of smaller amplitude than the primary corrugations and disposed angularly with respect to the primary corrugations.
10. A film pack as claimed in Claim 9, in which the primary and auxiliary corrugations are mutually orthogonal to one another.
11. A film pack as claimed in any one of Claims 6 to 10, in which the angle of the primary corrugations where each intermediate element intersects its median plane is between 30° and 60° .
12. A film pack as claimed in Claim 11, in which the angle of the primary corrugations where each intermediate element intersects its median plane is 45° .

13. A film pack as claimed in any one of the preceding claims, in which the sheet elements are planar.

14. A film pack as claimed in Claim 13, which includes securing means for securing the sheet elements and intermediate elements together.

15. A film pack as claimed in Claim 14, in which the securing means are wire elements which can clip onto the sheet elements and intermediate elements to hold them together.

16. A film pack as claimed in Claim 14, in which the securing means are plastics securing elements which can simultaneously engage a sheet element and an adjacent intermediate element to hold them together.

17. A film pack as claimed in Claim 16, in which the securing elements define at least one clip formation which can clip onto a sheet element and an adjacent intermediate element to hold them together.

18. A film pack as claimed in Claim 17, in which the securing elements define at least two clip formations which can clip onto sheet elements and their adjacent intermediate elements.

19. A film pack as claimed in Claim 18, in which each

clip formation defined by a securing element defines two opposing legs which can simultaneously clip onto a sheet element and an adjacent intermediate element to hold them together.

20. A film pack as claimed in Claim 19, in which the opposing legs clip onto an edge region of a sheet element and an adjacent intermediate element.

21. A film pack as claimed in Claim 20 in which the opposing legs project from a base portion which is common to at least two pairs of opposing legs, all the legs lying in the same plane.

22. A film pack as claimed in any one of Claims 19 to 21, in which the opposing legs define edge regions complimentary to the regions of the sheet elements or intermediate elements which they engage to enhance such engagement.

23. A film pack as claimed in any one of Claims 19 to 22, in which at least one leg of a pair of opposing legs defines a serrated edge region to enhance engagement with a sheet element or intermediate element which it engages for holding together a sheet element and an intermediate element.

24. A film pack as claimed in any one of Claims 14 to 23, in which the securing means secure together the sheet elements and intermediate elements on at least two sides of the pack so

as to hold an entire pack together.

25. A film pack as claimed in any one of Claims 1 to 12, in which the sheet elements are corrugated.

26. A film pack as claimed in Claim 25, in which the intermediate elements include additional locating corrugations complimentary to the corrugations of the sheet elements so that the sheet elements and intermediate elements nest within one another.

27. A film pack as claimed in Claim 26, insofar as it is dependant on Claim 7 and Claim 9, in which the locating corrugations of the intermediate elements are mutually orthogonal with respect to the primary corrugations and are of larger amplitude than the auxiliary corrugations.

28. A film pack as claimed in Claim 27, in which the sheet elements and the intermediate elements are located with respect to one another by the location of the outer sheet elements.

29. A film pack as claimed in Claim 1 or Claim 2 in which the sheet elements are corrugated, the corrugations being vertically disposed in the operative configuration of the film pack.

30. A film pack as claimed in Claim 29, in which adjacent sheet elements are arranged so that the peaks of the corrugations of one element abut the valleys of the corrugations of an adjacent element, thereby defining a series of spaces between adjacent elements within which intermediate elements are disposed.

31. A film pack as claimed in Claim 29, in which the corrugated sheet elements abut additional planar sheet elements disposed between them, spaces being defined between the corrugated and planar sheet elements within which intermediate elements are disposed.

32. A film pack as claimed in Claim 29 to 31 in which the intermediate elements are in the form of corrugated sheets.

33. A film pack as claimed in Claim 32, in which the intermediate elements define primary corrugations which are adapted so that the intermediate elements fit into the spaces defined between the sheet elements abutting both such sheet elements.

34. A film pack as claimed in Claim 33, in which the intermediate elements define auxiliary corrugations of smaller amplitude than the primary corrugation and mutually orthogonal therewith.

35. A film pack as claimed in any one of the preceding claims, which includes end spacers disposed between the sheet elements at opposite side ends of the pack.

36. A film pack as claimed in any one of the preceding claims, adapted to be supported on a support structure therefore in a cooling tower.

37. A film pack substantially as described in the specification with reference to and as illustrated in the accompanying drawings.

38. A cooling tower including a film pack as claimed in any one of Claims 1 to 37.

39. An asbestos cement sheet element for a film pack as claimed in any one of Claims 1 to 37.

40. A sheet-like intermediate element for a film pack as claimed in any one of Claims 1 to 37.

41. A securing means for a film pack as claimed in any one of Claims 14 to 24 or 37.

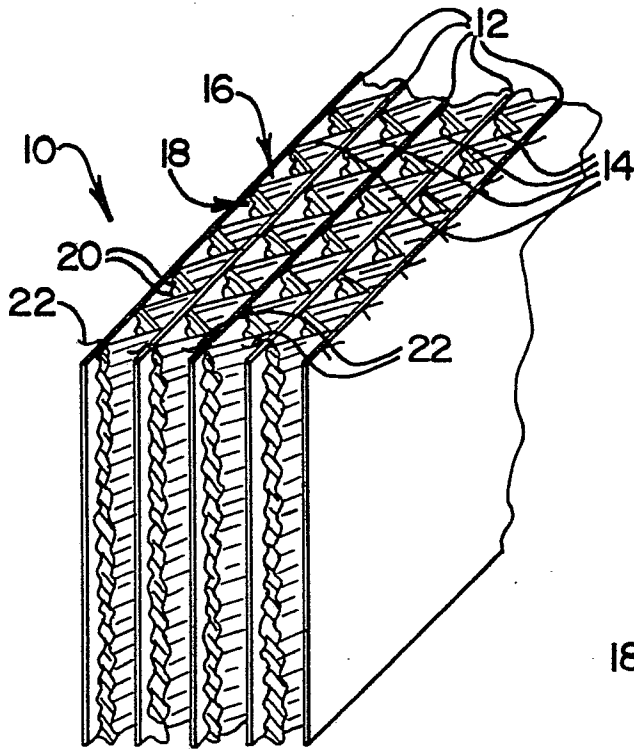

FIG. 1

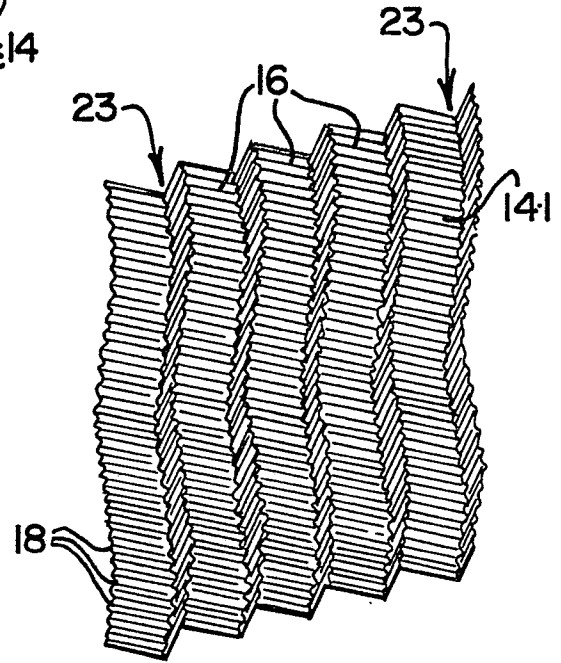

FIG. 1A

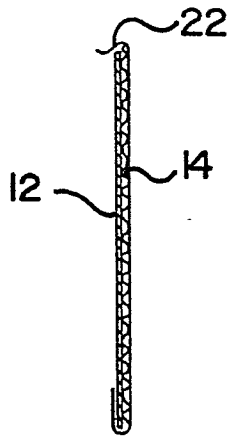

FIG. 2

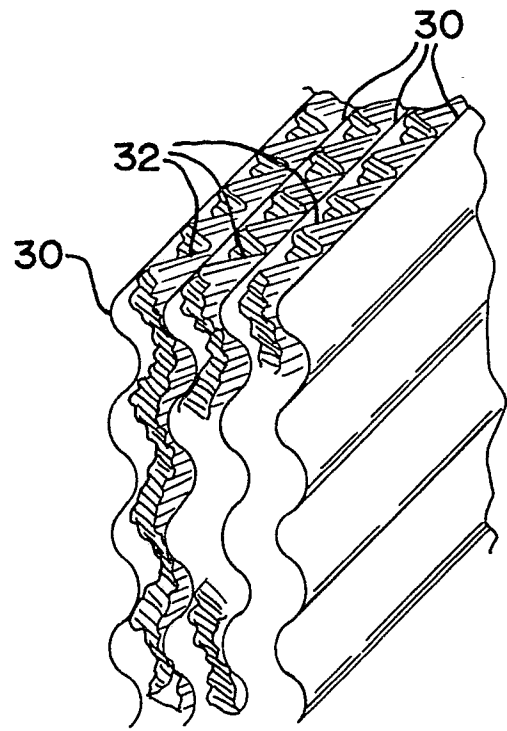

FIG. 3

2/4

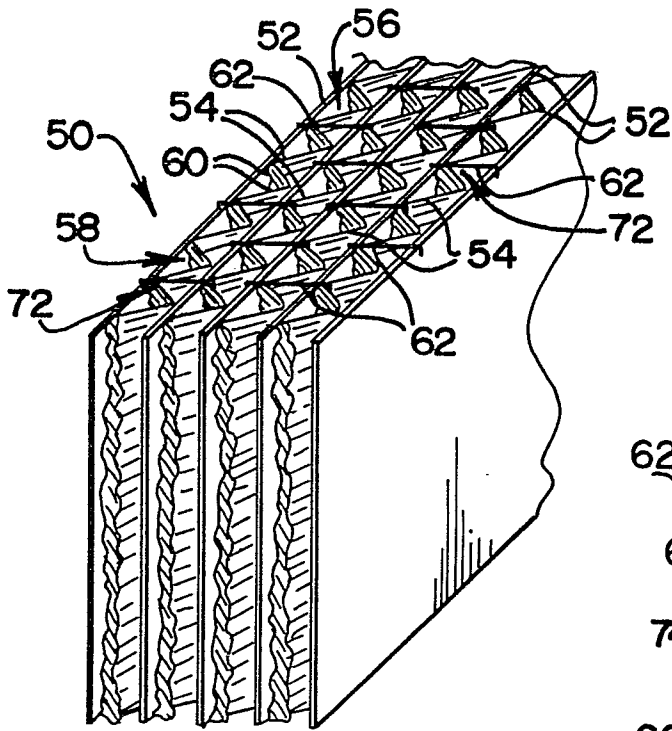

FIG. 4

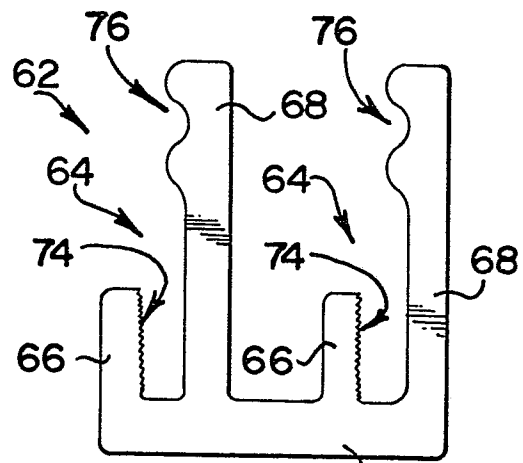

FIG. 5

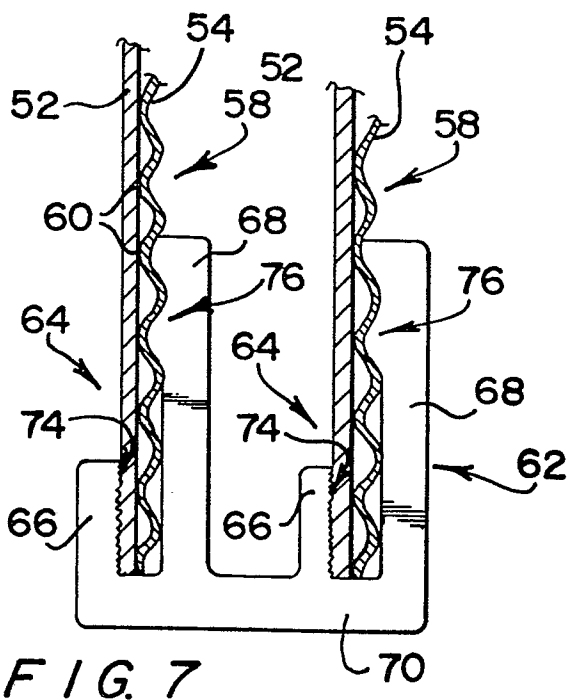

FIG. 7

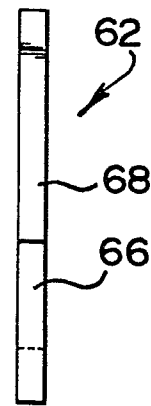

FIG. 6

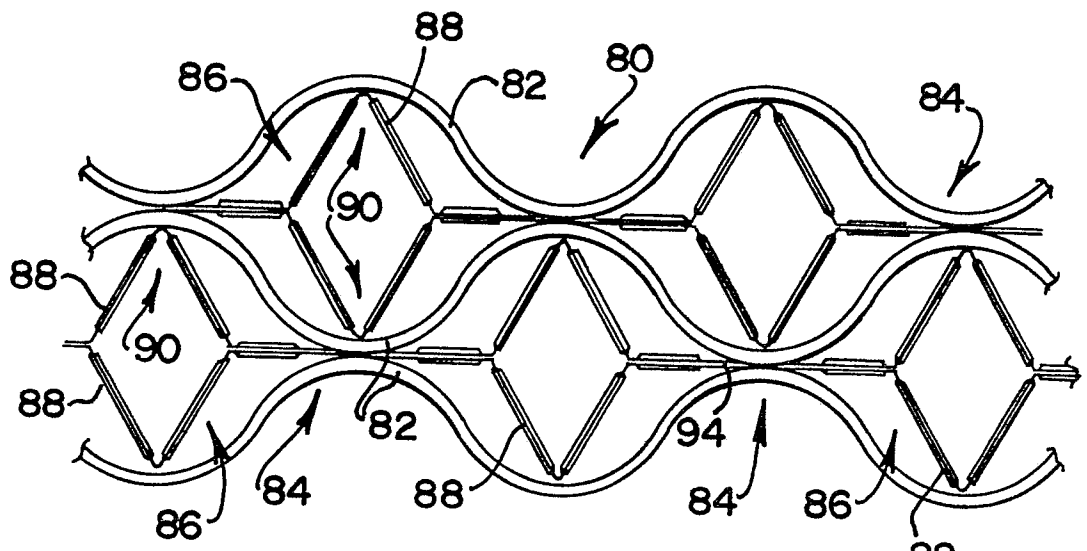

FIG. 8

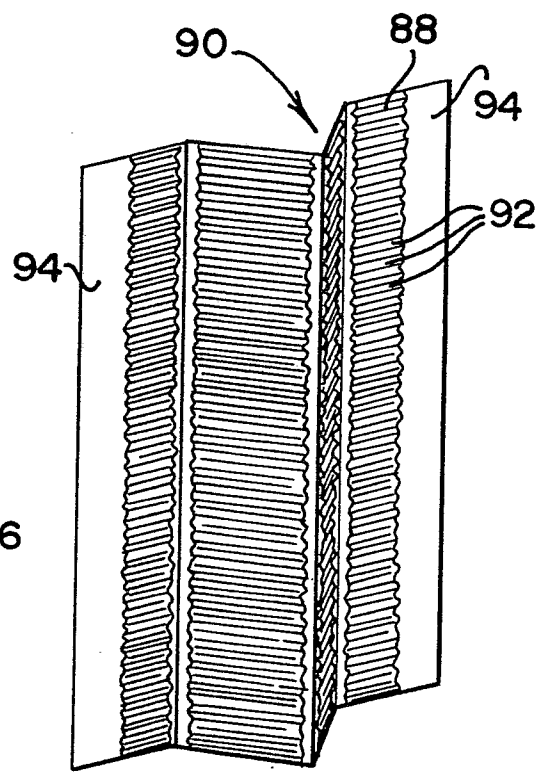

FIG. 9

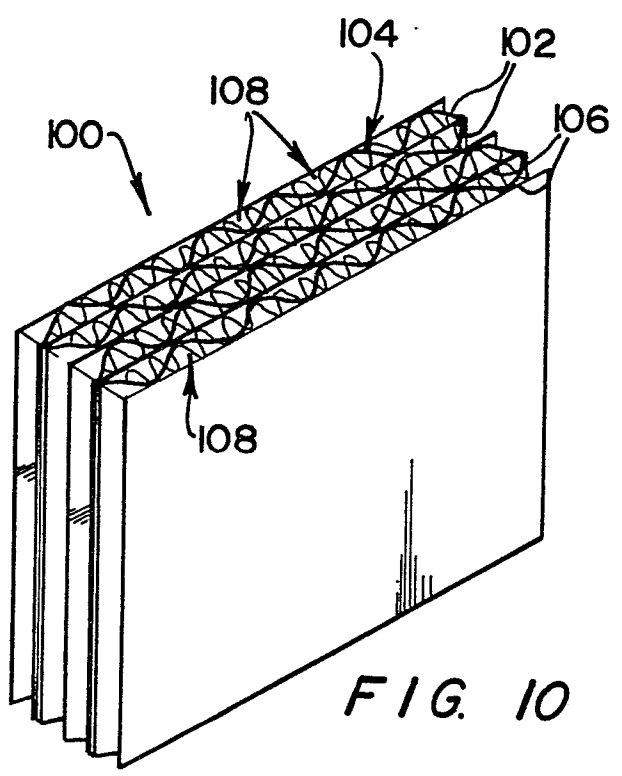

FIG. 10

