

(19) World Intellectual Property Organization
International Bureau



(43) International Publication Date
27 April 2006 (27.04.2006)

PCT

(10) International Publication Number
WO 2006/044570 A2

- (51) International Patent Classification:
A45D 1/00 (2006.01) A45D 1/04 (2006.01)
- (21) International Application Number:
PCT/US2005/036884
- (22) International Filing Date: 13 October 2005 (13.10.2005)
- (25) Filing Language: English
- (26) Publication Language: English
- (30) Priority Data:
60/618,461 13 October 2004 (13.10.2004) US
- (71) Applicant (for all designated States except US): CONAIR CORPORATION [US/US]; One Cummings Point Road, Stamford, CT 06902 (US).
- (72) Inventor; and
- (75) Inventor/Applicant (for US only): FUNG, Kam, Fai [CN/CN]; Block 7, Flat D, 20/Floor, Melody Garden, Tuen Mun, Hong Kong (CN).
- (74) Agent: GARNER, Steven, A.; Conair Corporation, One Cummings Point Road, Stamford, CT 06902 (US).

- (81) Designated States (unless otherwise indicated, for every kind of national protection available): AE, AG, AL, AM, AT, AU, AZ, BA, BB, BG, BR, BW, BY, BZ, CA, CH, CN, CO, CR, CU, CZ, DE, DK, DM, DZ, EC, EE, EG, ES, FI, GB, GD, GE, GH, GM, HR, HU, ID, IL, IN, IS, JP, KE, KG, KM, KP, KR, KZ, LC, LK, LR, LS, LT, LU, LV, LY, MA, MD, MG, MK, MN, MW, MX, MZ, NA, NG, NI, NO, NZ, OM, PG, PH, PL, PT, RO, RU, SC, SD, SE, SG, SK, SL, SM, SY, TJ, TM, TN, TR, TT, TZ, UA, UG, US, UZ, VC, VN, YU, ZA, ZM, ZW.
- (84) Designated States (unless otherwise indicated, for every kind of regional protection available): ARIPO (BW, GH, GM, KE, LS, MW, MZ, NA, SD, SL, SZ, TZ, UG, ZM, ZW), Eurasian (AM, AZ, BY, KG, KZ, MD, RU, TJ, TM), European (AT, BE, BG, CH, CY, CZ, DE, DK, EE, ES, FI, FR, GB, GR, HU, IE, IS, IT, LT, LU, LV, MC, NL, PL, PT, RO, SE, SI, SK, TR), OAPI (BF, BJ, CF, CG, CI, CM, GA, GN, GQ, GW, ML, MR, NE, SN, TD, TG).

Published:
— without international search report and to be republished upon receipt of that report

For two-letter codes and other abbreviations, refer to the "Guidance Notes on Codes and Abbreviations" appearing at the beginning of each regular issue of the PCT Gazette.

(54) Title: SPLIT-BARREL LOCKING MECHANISM FOR HAIR APPLIANCE

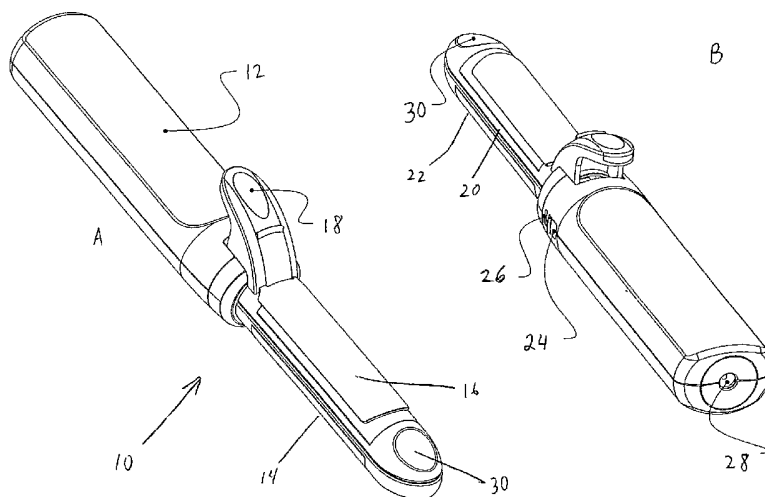

(57) Abstract: A hair-straightening device (10) has a handle (12), a barrel (14), a spoon (16) and a thumb rest (18). The barrel (14) is comprised of an upper barrel (20) and a lower barrel (22). The thumb rest (18) includes a spoon lock (32) that enables a user to choose between using the hair device (10) as a hair-straightening appliance or as a curling iron. When the thumb rest (18) is in a pulled back position, the spoon lock (32) is disengaged from the barrel connector (34) and upper barrel (20). As such, as the thumb rest (18) is depressed, the hinge (36) pivots about its axis, causing the spoon (16) to open with respect to the barrel (14). The user can then operate the device as a curling iron. When the thumb rest (18) is in the forward position, the spoon lock (32) engages the barrel connector (34), which is connected to the upper barrel end (38). As the user depresses the thumb rest (18), the barrel connector (34) and upper barrel end (38) pivot about the hinge (36). This causes the entire upper barrel (20) to open, rather than just the spoon (16). The user can then operate the device as a straightening iron.

WO 2006/044570 A2

SPLIT-BARREL LOCKING MECHANISM FOR HAIR APPLIANCE**RELATED APPLICATIONS**

This application claims priority to U.S. Provisional Patent Application Serial No. 60/618,461 filed on October 13, 2004, incorporated herein by reference in its entirety.

TECHNICAL FIELD

The present invention relates to hair appliances and, more particularly, to a locking mechanism for a hair-straightening device, especially of the type that enables a user to easily alternate between a hair straightening device and a curling iron.

BACKGROUND OF THE INVENTION

It is known in the art to provide a hair-straightening device having a pair of opposing arms joined by a hinge, in which the arms contain heated plates that are adapted to grip a strand of hair and straighten the hair between the plates through the use of heat and tension. There have been numerous variations manufactured with combs or brushes added adjacent to the plates and variations having steam or ionic features enhancing the heated plates.

It is also known in the art to provide hair-curling devices, which use electrical heating elements to heat a cylindrical surface around which a strand of hair is wrapped to apply heat to the hair. These curling irons also have a spring-biased clamp, having a partial cylindrical section, which engages the cylinder around which the strand of hair is wrapped. The clamp facilitates curling of the hair by holding the hair firmly against the cylinder. The clamp is typically biased against the cylinder and is pivoted away from the cylinder by the pressing of a handle by the user. When the handle on the clamp is released, the clamp engages the cylinder.

While various known hair-straightening devices and hair-curling devices exist generally, there is a need for a device that comprises both a hair straightening-device and a hair-curling device in one easily interchangeable device. Other known devices require using two separate devices for the tasks of straightening hair and curling hair. This increases the cost for having multiple hair appliances as well as taking up more space in an often limited area such as a bathroom or salon area. Such shortcomings make it desirable to provide a mechanism that would conveniently enable a hair appliance to comprise both a hair-straightening device and a hair-curling device in one appliance.

OBJECT AND SUMMARY OF THE INVENTION

It is an object of the invention to provide a hair-styling device that overcomes the above-mentioned shortcomings.

It is a further object of the present invention to provide a hair appliance that combines the features of a hair-straightening device and a hair-curling device in one easily convertible appliance. These and other objects are described below or inherent with respect to the present invention.

In the preferred embodiment of the invention, a hair-appliance comprises a handle, a barrel, a spoon and a thumb rest. The barrel is comprised of an upper barrel and a lower barrel. The hair appliance can also include an on/off switch, a power indicator, a charging socket and a cool-tip for easier handling of the hair device.

The thumb rest includes a spoon lock that enables a user to choose between using the hair device as a hair-straightening appliance or as a curling iron. When the thumb rest is in a pulled back position, the spoon lock is disengaged from the barrel connector and upper barrel. As such, as the thumb rest is depressed, the hinge pivots about its axis,

causing the spoon to open with respect to the barrel. The user can then operate the device as a curling iron.

When the thumb rest is in the forward position, the spoon lock engages the barrel connector, which is connected to the upper barrel end. As the user depresses the thumb rest, the barrel connector and upper barrel end pivot about the hinge. This causes the entire upper barrel to open, rather than just the spoon. The user can then operate the device as a straightening iron.

BRIEF DESCRIPTION OF THE DRAWINGS

Fig. 1A is a front perspective view of a preferred embodiment of a hair device according to the present invention.

Fig. 1B is a rear perspective view of a preferred embodiment of the hair device according to the present invention.

Fig. 2A is a side, partial section view of a preferred embodiment of a hair device according to the present invention.

Fig. 2B is a partly magnified view of the hair device with the locking mechanism unlocked.

Fig. 2C is a partly magnified view of the hair device with the locking mechanism locked.

Fig. 3A is a front perspective view of the hair device with the locking mechanism unlocked and the device in the closed position.

Fig. 3B is a front perspective view of the hair device with the locking mechanism unlocked and the device in the open position.

Fig. 3C is a partly magnified view of Fig. 3A according to the present invention.

Fig. 4A is a front perspective view of the hair device with the locking mechanism locked and the device in the closed position.

Fig. 4B is a front perspective view of the hair device with the locking mechanism locked and the device in the open position.

Fig. 4C is a partly magnified view of Fig. 4A according to the present invention.

Fig. 5A is a bottom view of the hair device according to an alternate embodiment of the present invention.

Fig. 5B is a cross-sectional view of the hair device of Fig. 5A.

Fig. 5C is a partly magnified view of the hair device with the locking mechanism unlocked according to an alternate embodiment of the present invention.

Fig. 5D is a partly magnified view of the hair device with the locking mechanism locked according to an alternate embodiment of the present invention.

Fig. 6 is a perspective view of a hair device according to another alternate embodiment of the present invention.

DESCRIPTION OF THE PREFERRED EMBODIMENTS

Referring to Figs. 1A and 1B, the present invention is described in the preferred embodiments as directed to a hair appliance 10 that can be used as either a hair-straightening device or a curling iron. The hair appliance 10 may include a handle 12, a barrel 14, a spoon 16 and a thumb rest 18. The barrel 14 is comprised of an upper barrel 20 and a lower barrel 22. The hair appliance 10 can also include an on/off switch 24, a power indicator 26, a charging socket 28 and a cool-tip 30 for easier handling of the hair device 10.

As shown in Figs. 2A to 2C, the thumb rest 18 includes a spoon lock 32 that enables a user to choose between using the hair device 10 as a hair-straightening

appliance or as a curling iron. Fig. 2B shows the device 10 in the unlocked position. The thumb rest 18 is in a pulled back position. This causes the spoon lock 32 to be disengaged from the barrel connector 34 and upper barrel 20. As such, as the thumb rest 18 is depressed, the hinge 36 pivots about its axis, causing the spoon 16 to open with respect to the barrel. The user can then operate the device 10 as a curling iron.

Fig. 2C shows the device 10 in the locked position. The thumb rest 18 is in the forward position. This causes the spoon lock 32 to engage the barrel connector 34, which is connected to the upper barrel end 38. As the user depresses the thumb rest 18, the barrel connector 34 and upper barrel end 38 pivot about the hinge 36. This causes the entire upper barrel 20 to open, rather than just the spoon 16. The user can then operate the device 10 as a straightening iron.

Figs. 3A to 3C show the entire device 10 with the spoon lock 32 in the back, unlocked position. A user could disengage the spoon lock 32 from the barrel connector 34 by pulling the thumb rest 18 backward with his or her thumb. By then depressing the thumb rest 18, the spoon 16 would pivot about the hinge 36 to an open position. The user could then place hair about the barrel 14 and release the thumb rest 18 to grasp the hair for curling.

Figs. 4A to 4C show the entire device 10 with the spoon lock 32 in the forward, locked position. A user could engage the spoon lock 32 with the barrel connector 34 by pushing the thumb rest 18 forward with his or her thumb. By then depressing the thumb rest 18, the spoon lock 32 would engage the barrel connector 34, which is connected to the upper barrel end 38. As such, the barrel connector 34 and the upper barrel end 38 would pivot about the hinge 36. This would cause the upper barrel 20 to open, rather

than just the spoon 16. A user could then place hair between the plates 40 of the upper barrel 20 and lower barrel 22 to grasp hair for straightening.

Figs. 5A-5D show an alternate embodiment of the present invention. This embodiment can use a switch 52, a plate 54 and a latch 56 to enable a user to use a hair appliance as either a hair-straightening device or a curling iron. When the switch 52, located on the lower barrel, is in a first position, as shown in Fig. 5C, the plate 54 catches the latch 56, which is located on the upper barrel, and prevents the upper barrel from being separated from the lower barrel. At this point, the user can use the hair appliance as a curling iron.

When the switch 52 is in a second position, as shown in Fig. 5D, the latch 56 is unobstructed by the plate 54. This enables the upper barrel to be separated from the lower barrel. At this point, the user can use the hair appliance as a straightening iron.

Fig. 6 shows another alternate embodiment, which uses a locking mechanism with a cam 60. As the switch 62 is rotated, the cam 60 rotates and obstructs the upper barrel from being separated from the lower barrel. When the switch 62 is rotated in the opposite direction, the cam 60 rotates along with it and the upper barrel is unobstructed so that it may be separated from the lower barrel.

While the preferred embodiments of the present invention have been described herein, various modifications can be made without departing from the scope of the invention.

What is claimed is:

1. A hair styling device comprising:
 - a barrel including a first portion and a second portion;
 - a hinge connecting said first portion and said second portion;
 - a clamp member to hold a user's hair; and
 - a locking mechanism adapted to be placed in a first position to enable separation of said clamp member from said barrel or a second position to enable separation of said first portion from said second portion.
2. A hair styling device according to claim 1, further comprising
 - an actuator to enable a user to separate said clamp member from said barrel when said locking mechanism is in said first position or to separate said first portion from said second portion when said locking mechanism is in said second position.
3. A hair styling device according to claim 2, further comprising
 - a connection member extending from said barrel in contact with said actuator.
4. A hair styling device according to claim 3, wherein
 - said actuator is unobstructed by said connection member when said locking member is in said first position to enable said clamp member to rotate about a hinge away from said barrel; and
 - said actuator is obstructed by said connection member when said locking member is in said second position to enable said first portion to rotate about a hinge away from said second portion.
5. A hair styling device according to claim 1, further comprising
 - a spring to bias said first portion away from said second portion.

6. A hair styling device according to claim 5, wherein
said locking mechanism comprises:
a latch on one of said first or second portions; and
a switch and a plate on the other of said first or second portions.
7. A hair styling device according to claim 6, wherein
said plate obstructs said latch, preventing said first portion from being separated from said second portion, when said switch is in a second position.
8. A hair styling device according to claim 6, wherein
said latch is unobstructed by said plate, enabling said first portion to be separated from said second portion, when said switch is in a first position.
9. A hair styling device according to claim 1, further comprising
a first heatable plate on said first arm for contacting a user's hair and a second heatable plate on said second arm for contacting a user's hair.
10. A hair styling device according to claim 1, wherein
a distal end of said first and/or said second portions are made from a material to maintain said distal end at a temperature lower than said first and/or second portions.

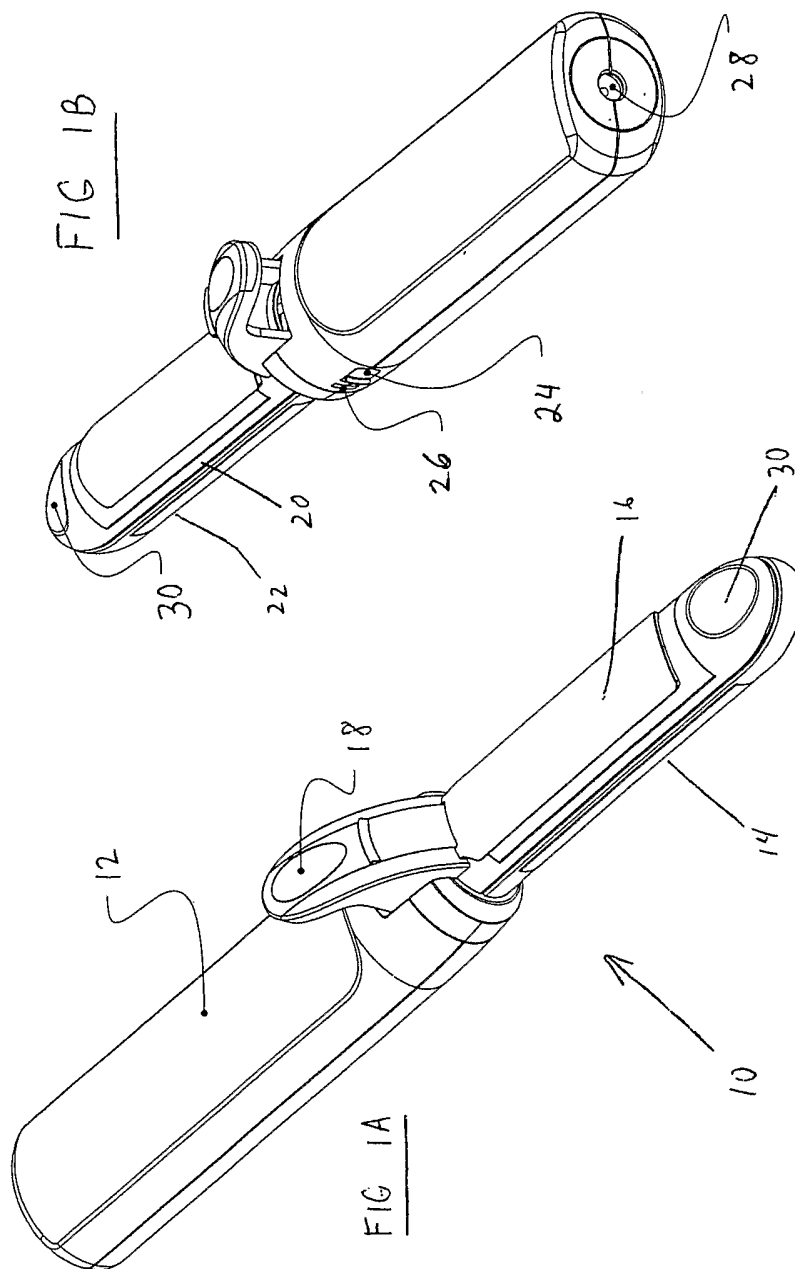

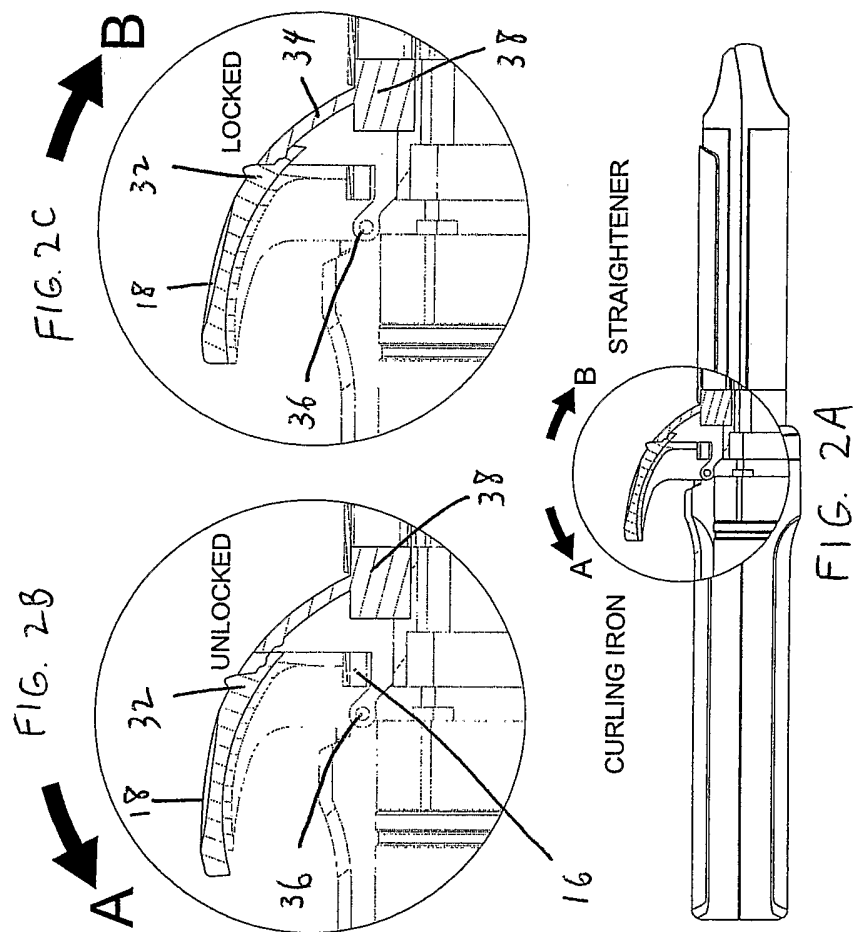

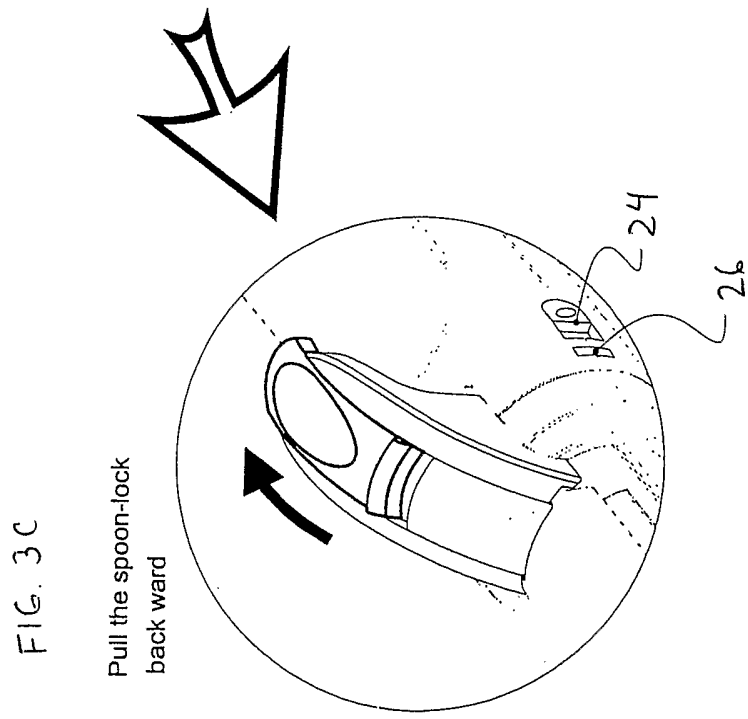
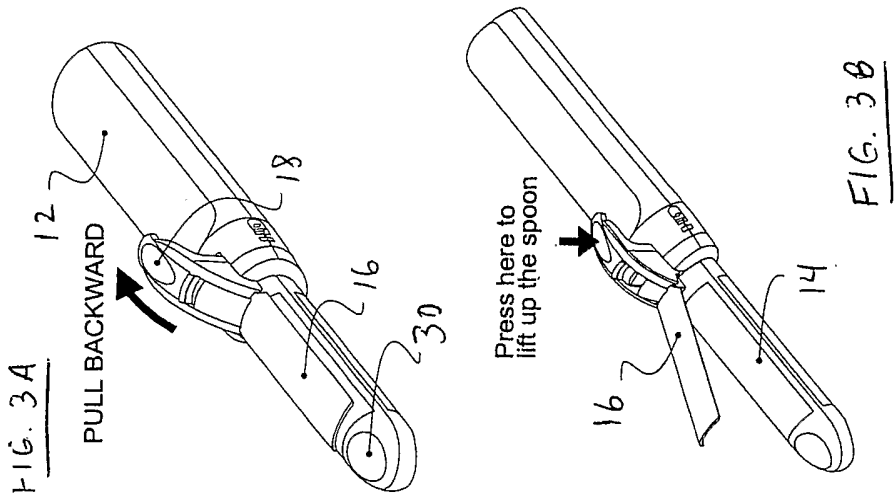

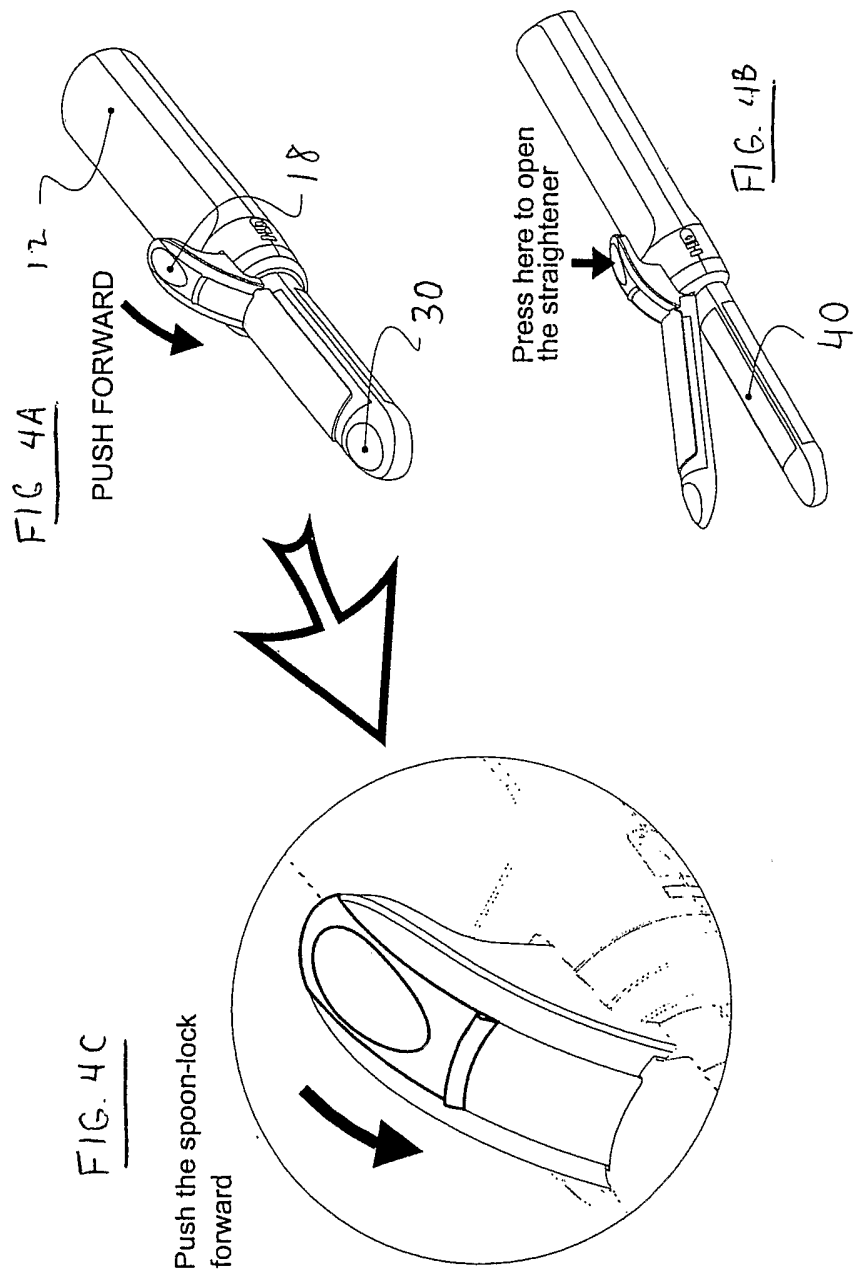

FIG. 5B

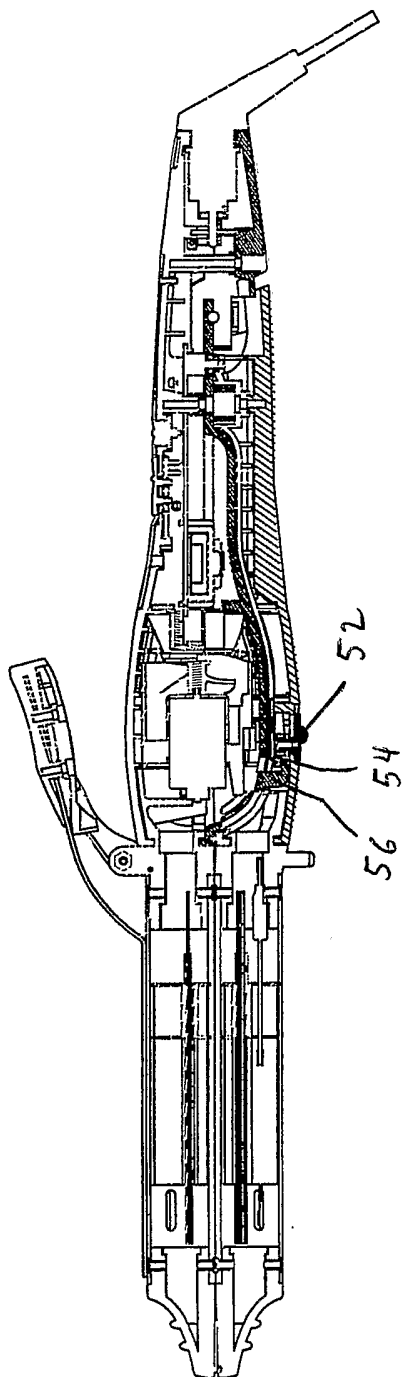
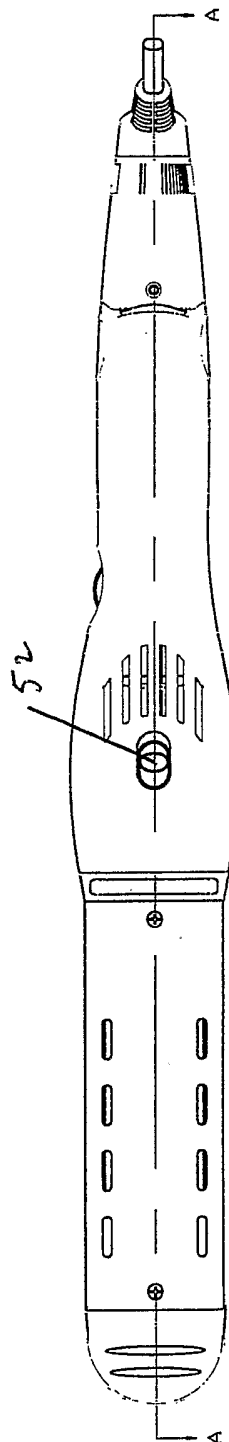

FIG. 5A



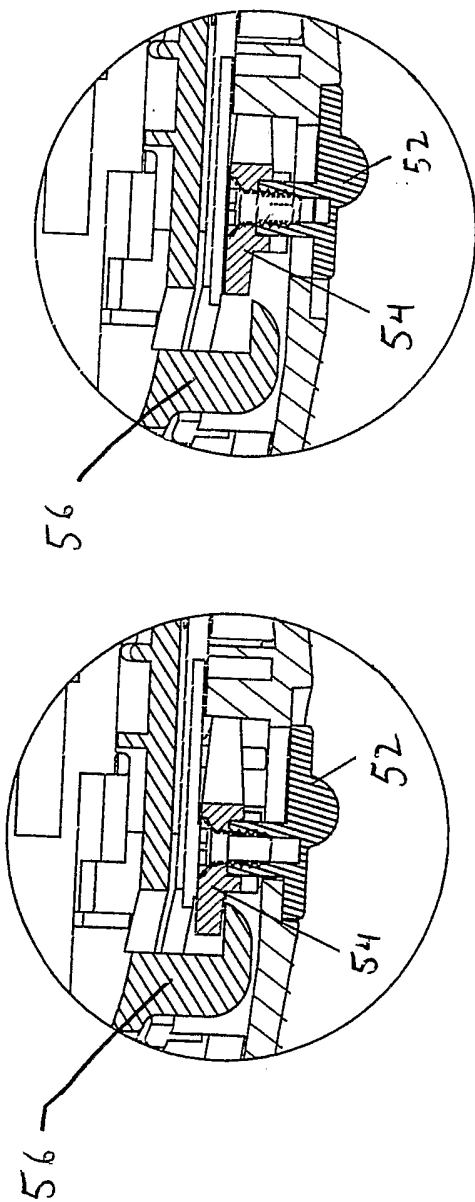

FIG. 5D

FIG. 5C

FIG. 6

