



US 20040045916A1

(19) **United States**

(12) **Patent Application Publication**

Klein et al.

(10) **Pub. No.: US 2004/0045916 A1**

(43) **Pub. Date: Mar. 11, 2004**

(54) **OVER-DOOR SHOE RACKS**

(60) Provisional application No. 60/149,794, filed on Aug. 19, 1999.

(76) Inventors: **Richard B. Klein**, Overland Park, KS (US); **Chris Serslev**, Leawood, KS (US); **John W. Scott**, Lenexa, KS (US)

Publication Classification

(51) **Int. Cl.⁷** **A47F 7/08**
(52) **U.S. Cl.** **211/35**

Correspondence Address:
SHOOK, HARDY & BACON LLP
2555 GRAND BLVD
KANSAS CITY,, MO 64108 (US)

(57) **ABSTRACT**

(21) Appl. No.: **10/657,303**

(22) Filed: **Sep. 8, 2003**

A shoe rack for mounting to an upright surface, or for hanging over a door, includes a pair of plastic, vertical side frame members and a plurality of shoe-retaining bars positioned between the side frame members upon which shoes, boxes and the like may be supported. A number of different embodiments are shown, each of which incorporates different features, and each of which may result in improved structural integrity over the prior art. Further, each embodiment may result in a product that is less expensive to manufacture and may result in a product which retains shoes on the shoe rack in a different, or better, manner.

Related U.S. Application Data

(60) Continuation-in-part of application No. 10/189,638, filed on Jul. 3, 2002, now Pat. No. 6,637,603, which is a division of application No. 09/641,323, filed on Aug. 18, 2000, now Pat. No. 6,533,127.

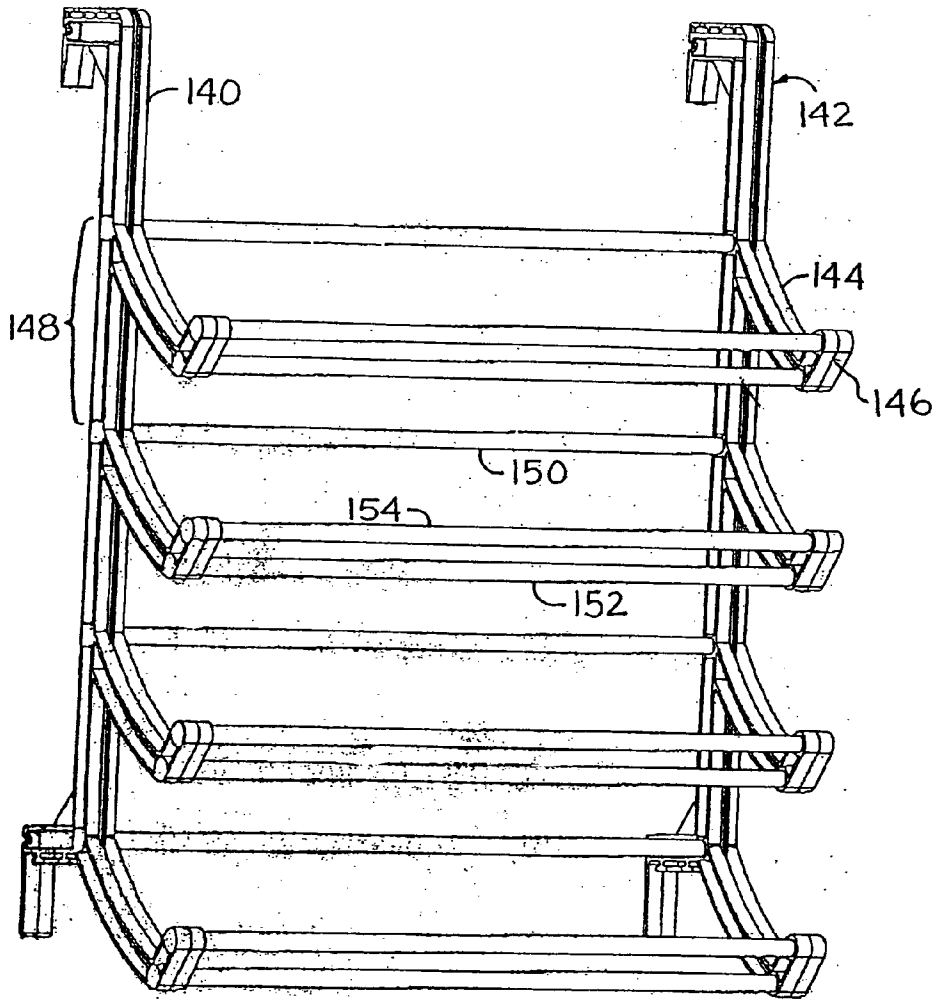

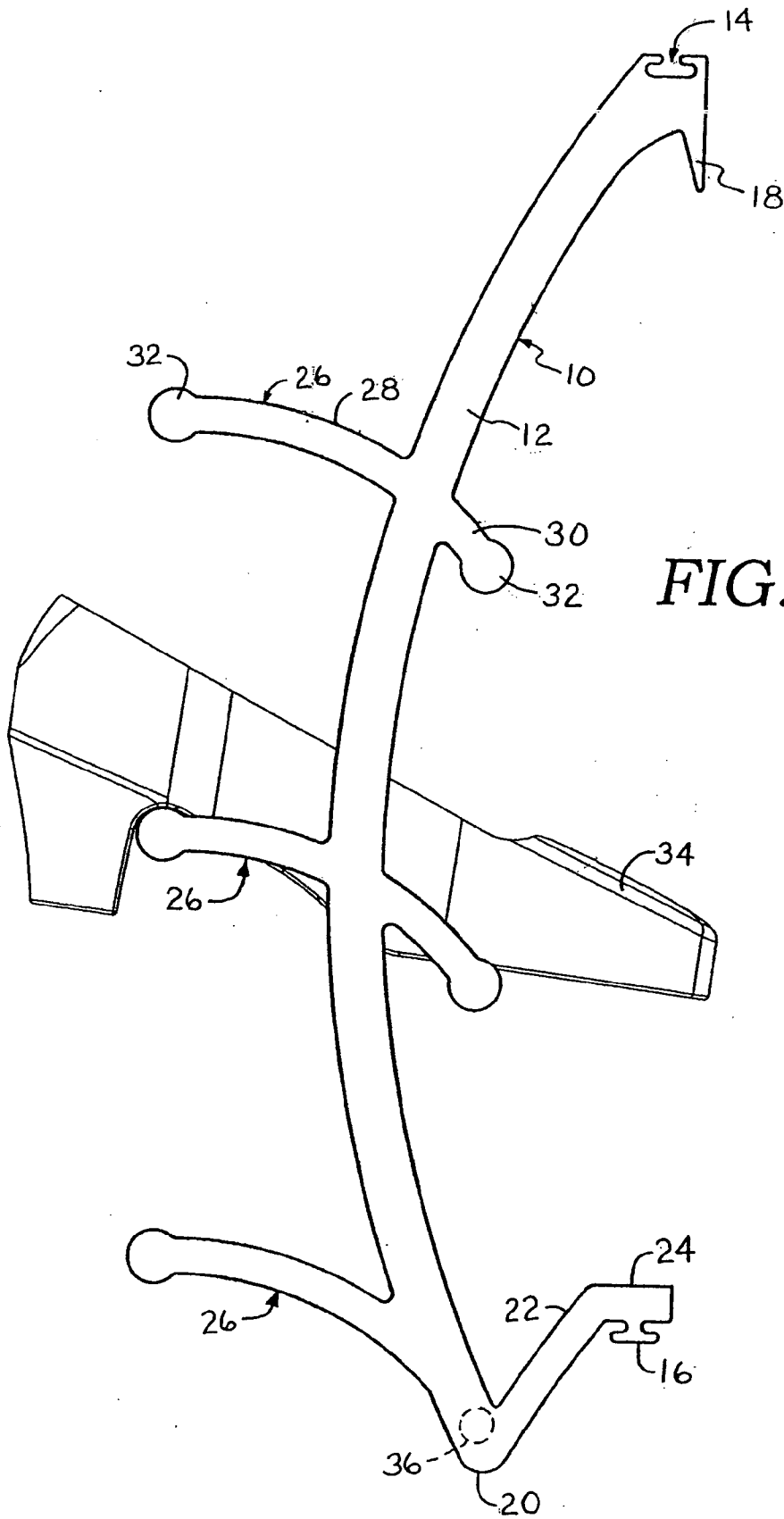

FIG. 1.

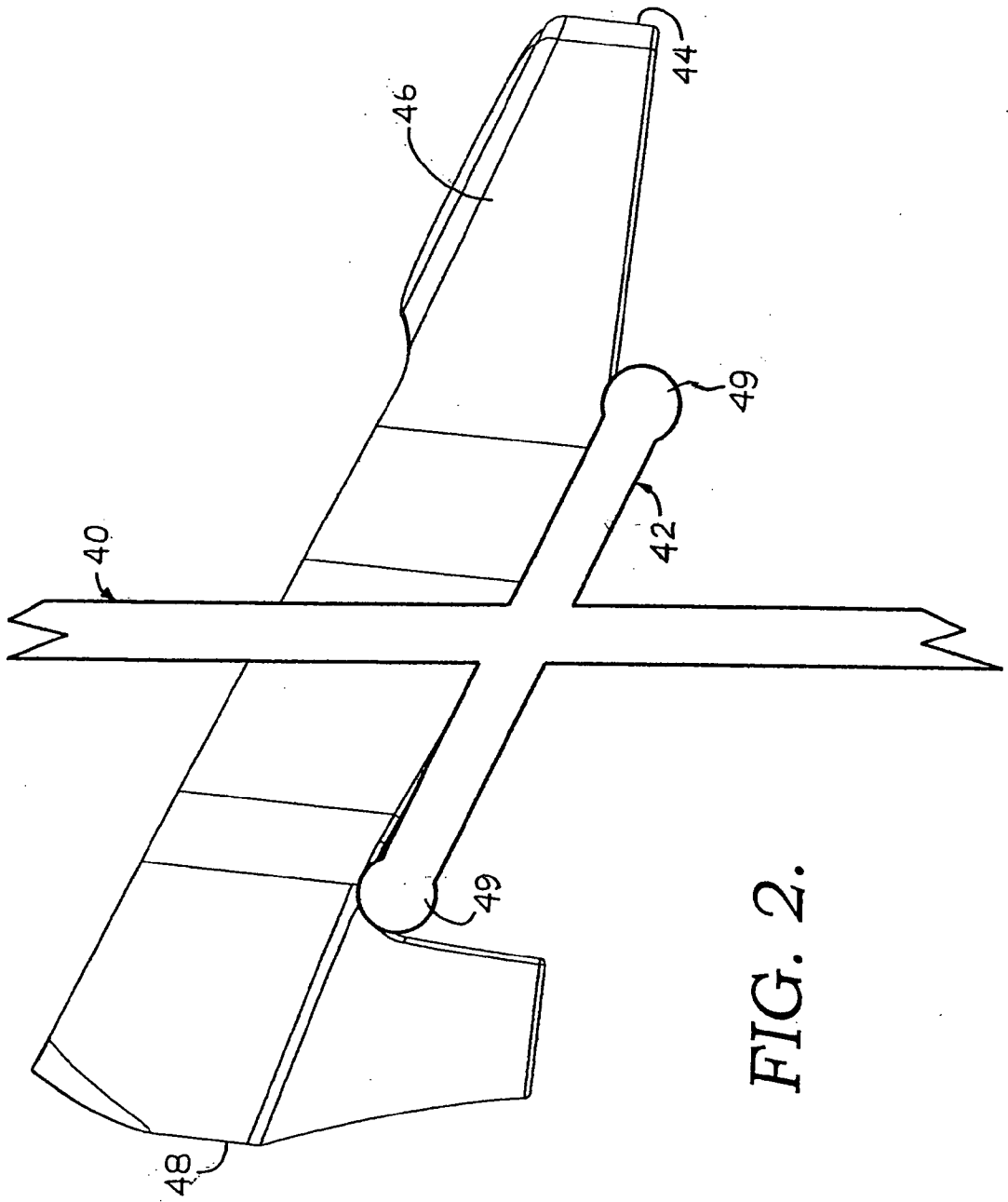

FIG. 2.

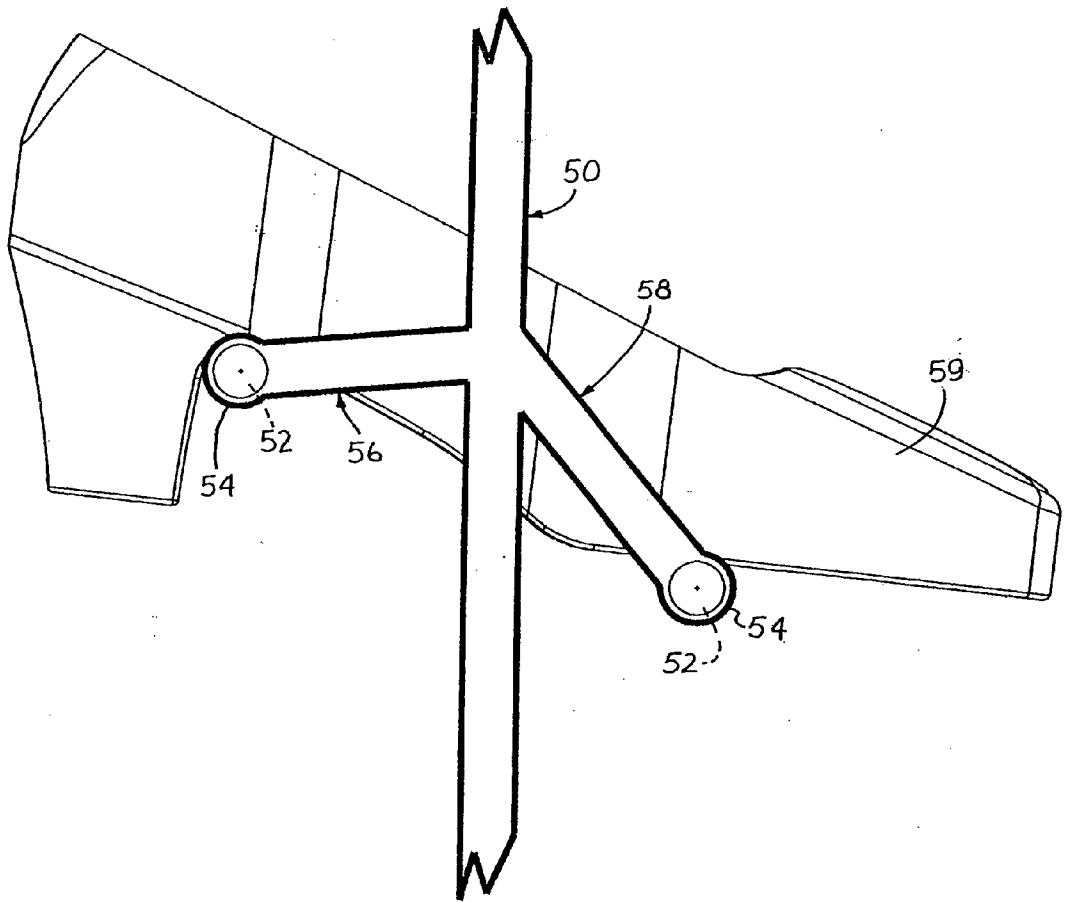

FIG. 3.

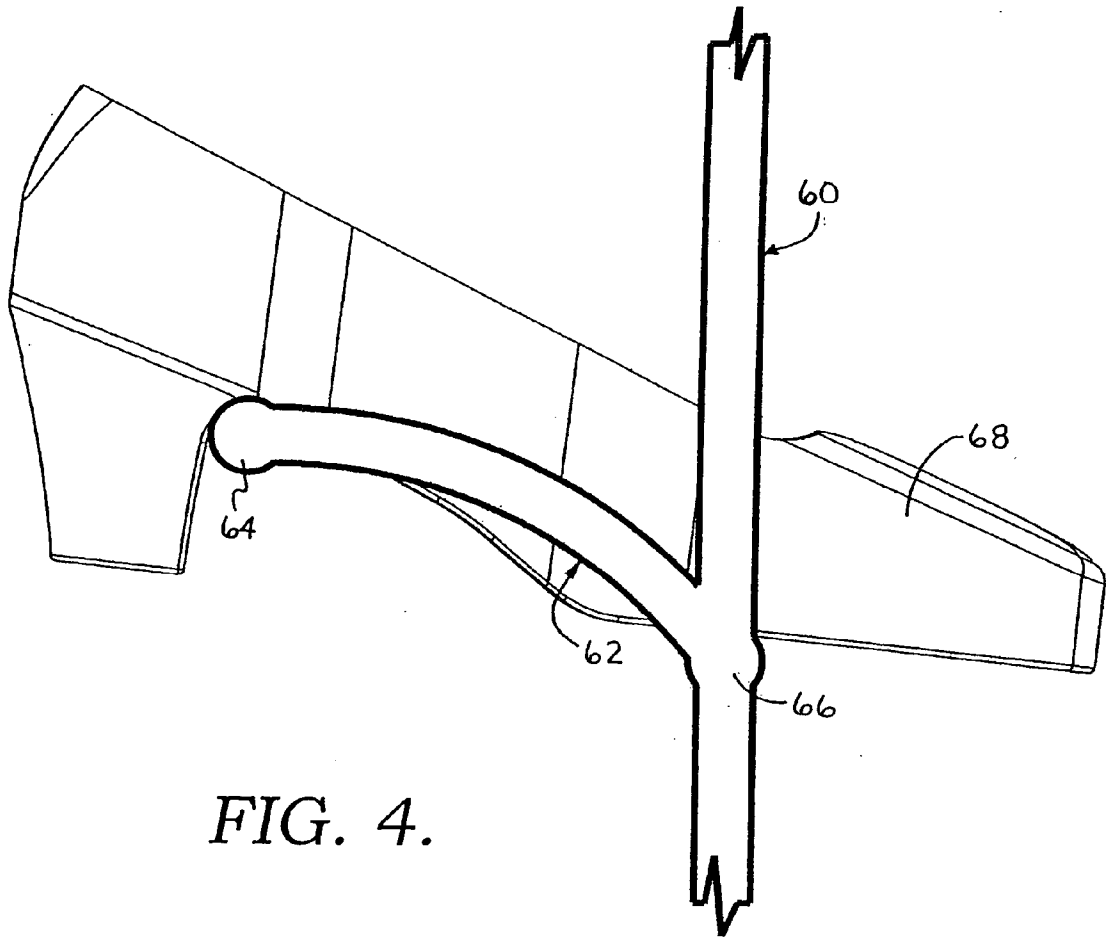

FIG. 4.

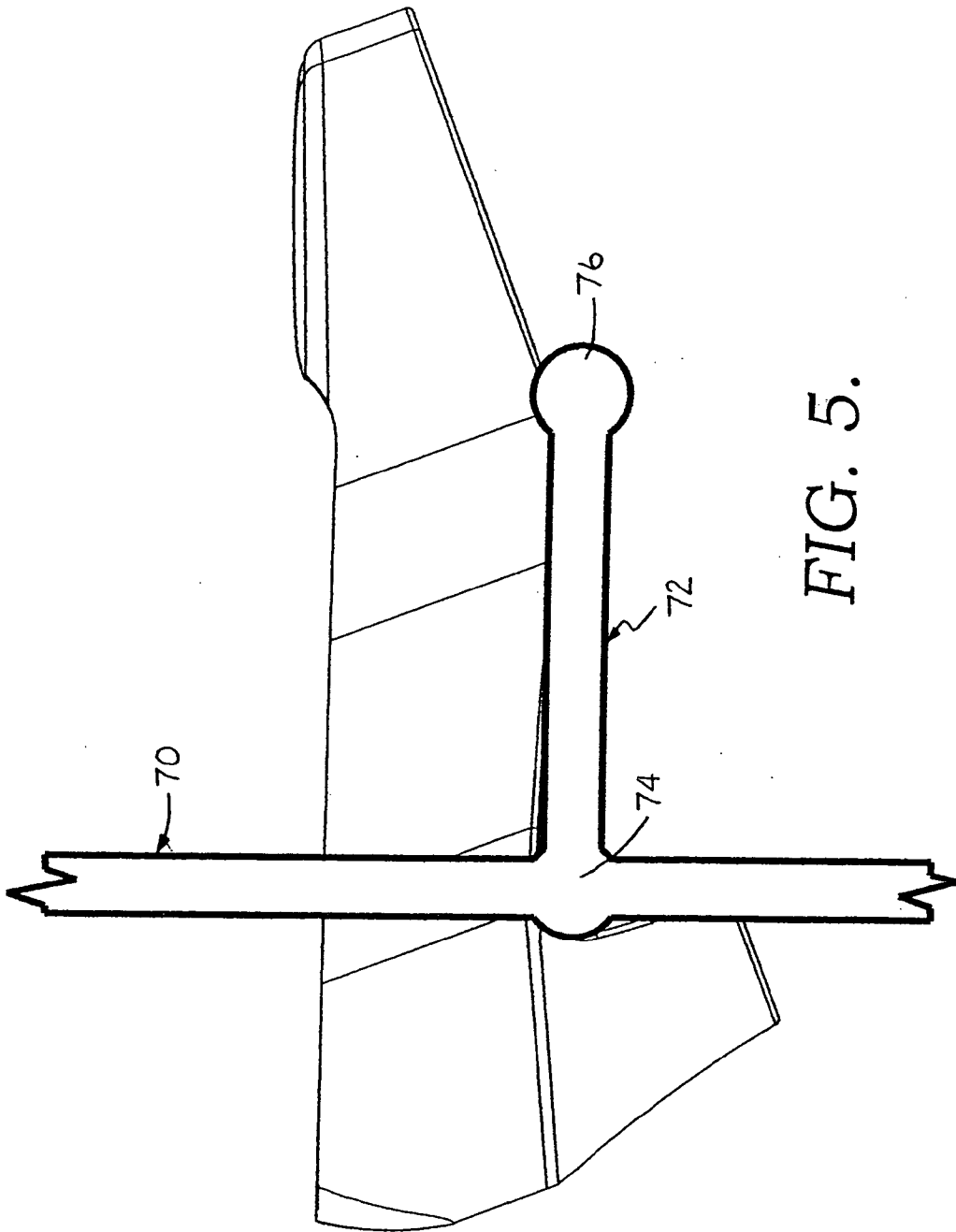

FIG. 5.

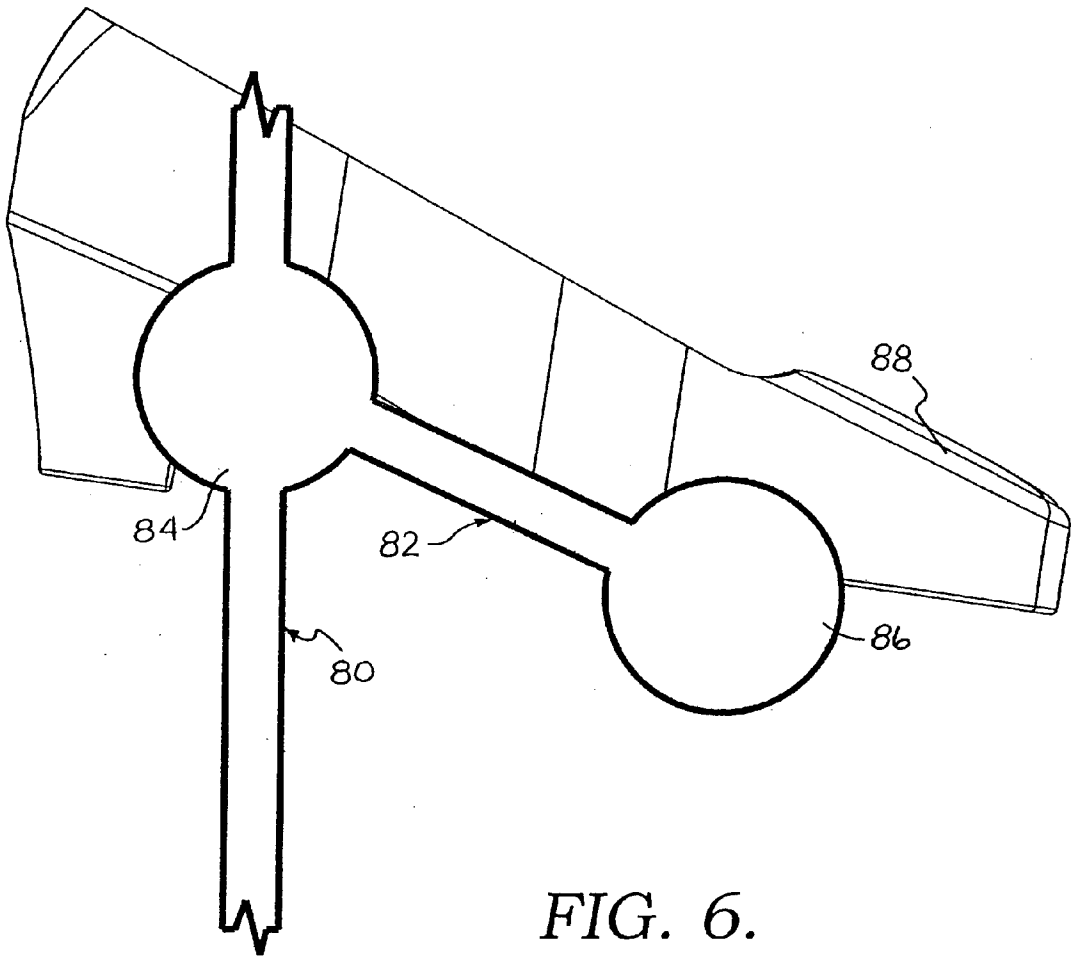

FIG. 6.

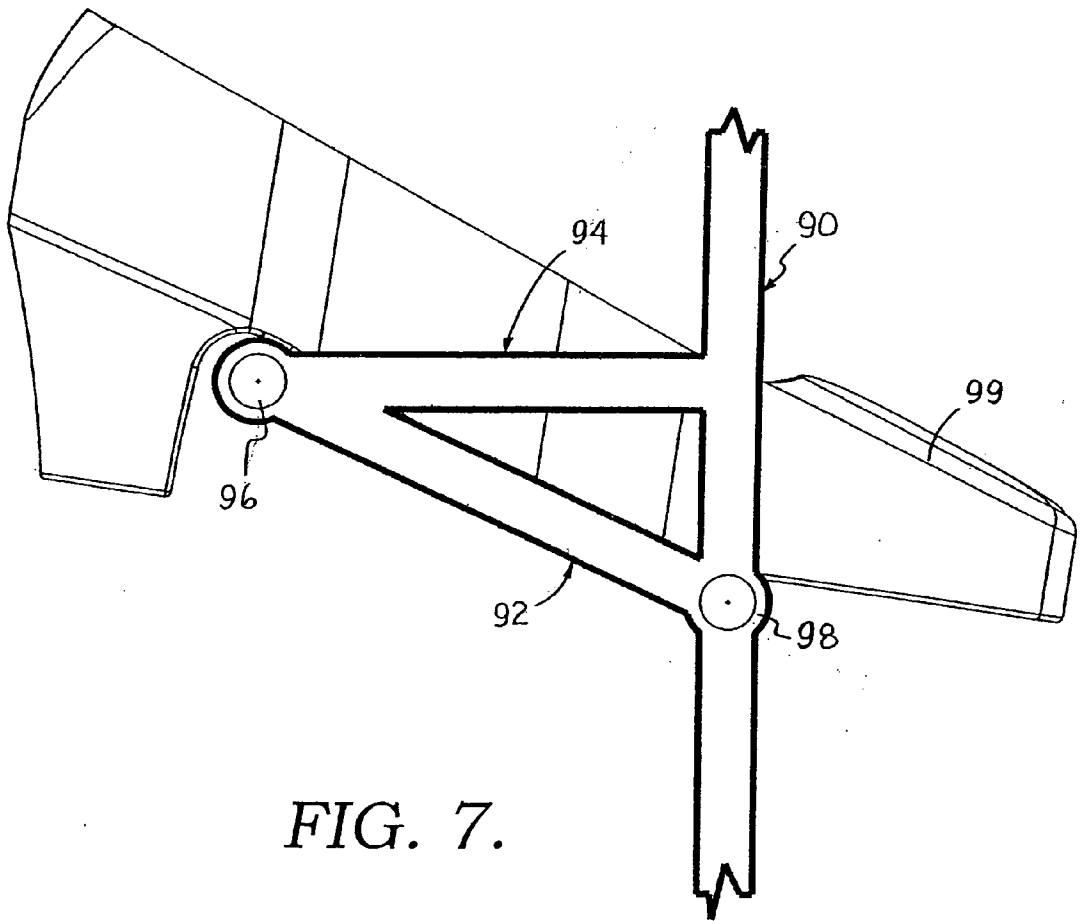

FIG. 7.

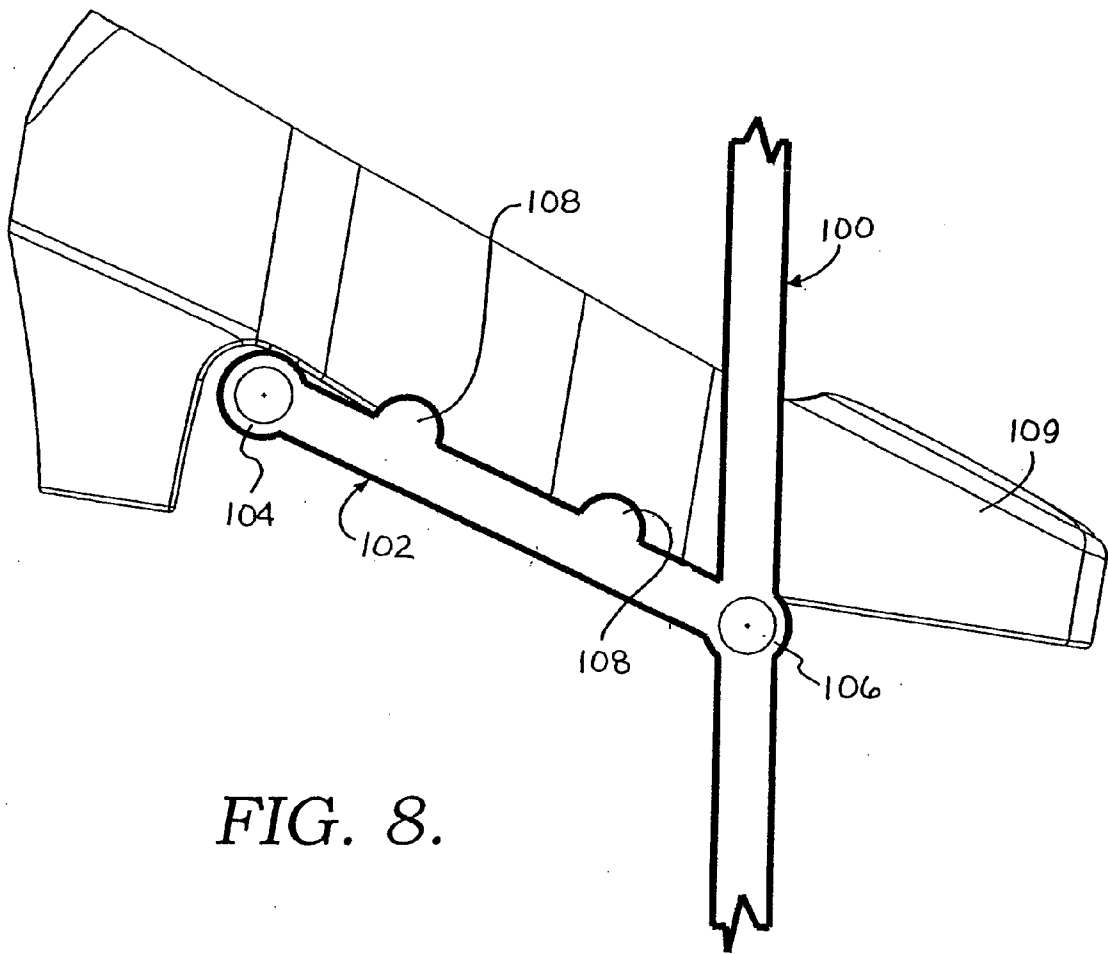

FIG. 8.

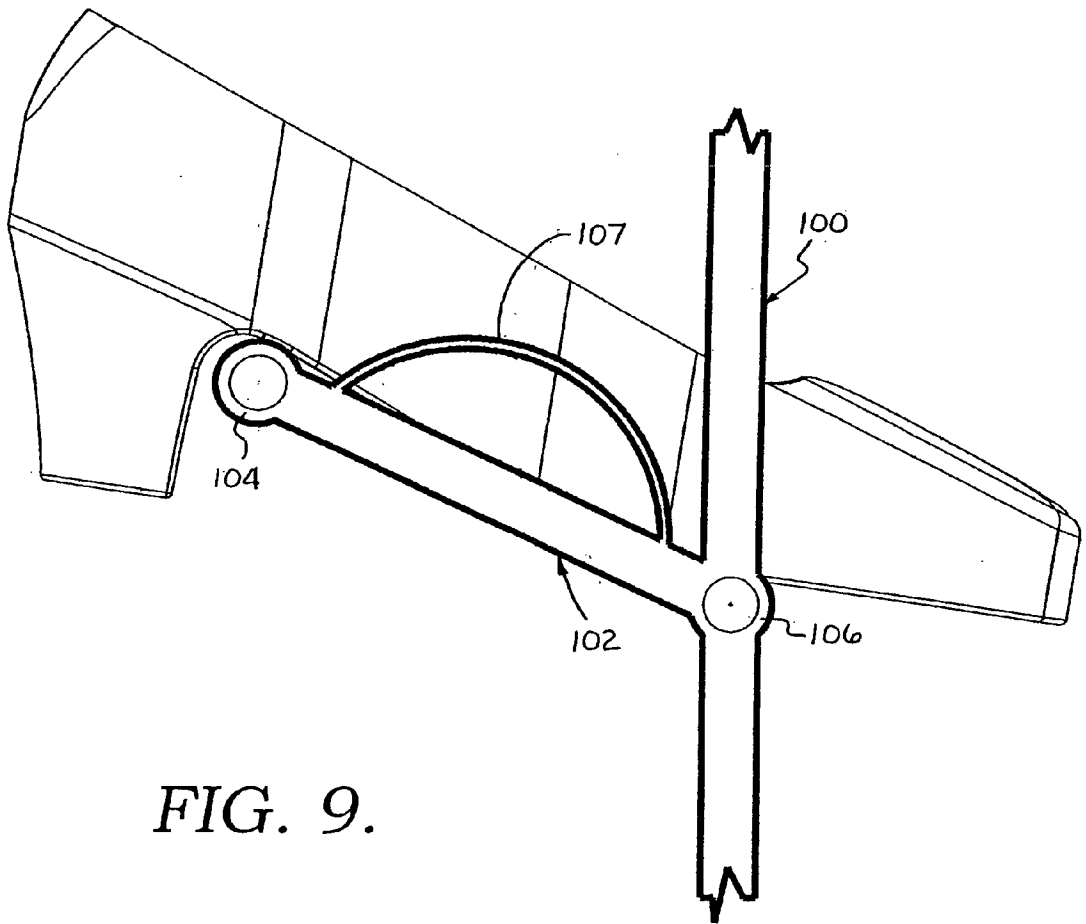

FIG. 9.

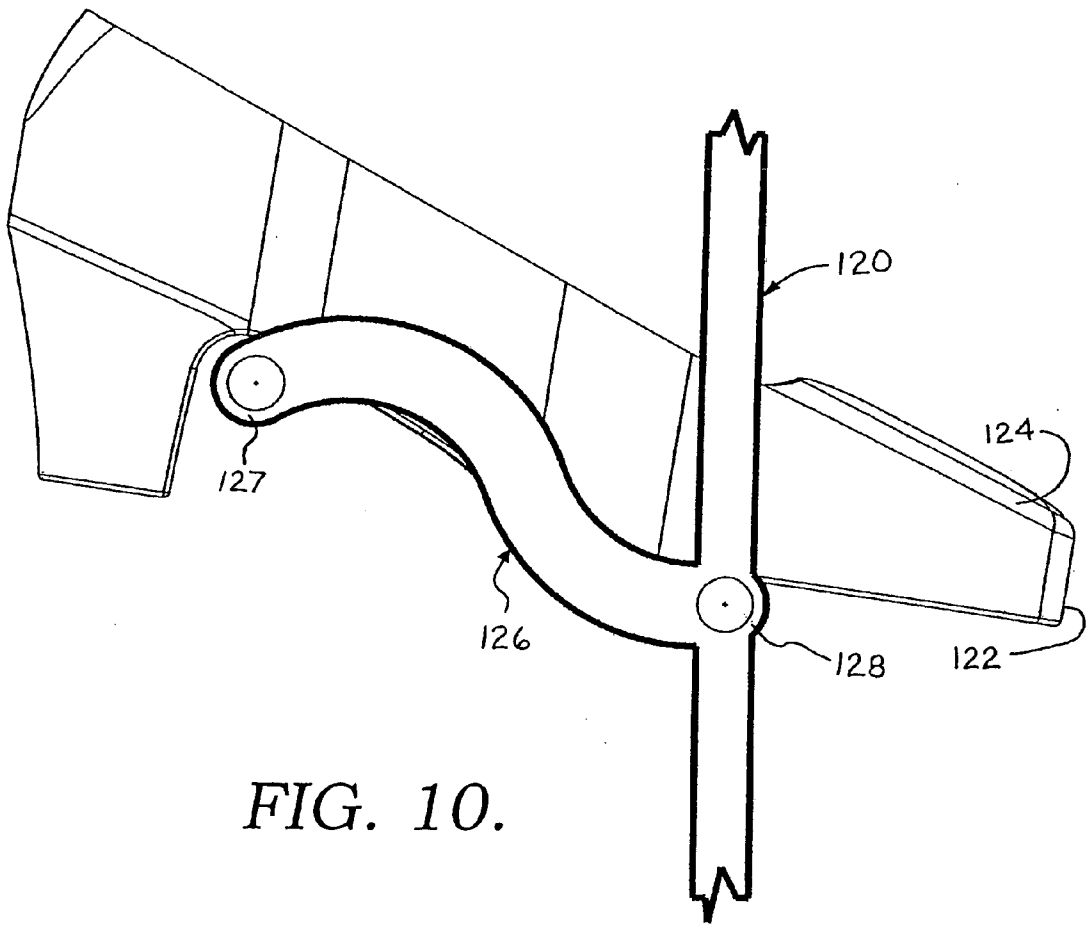

FIG. 10.

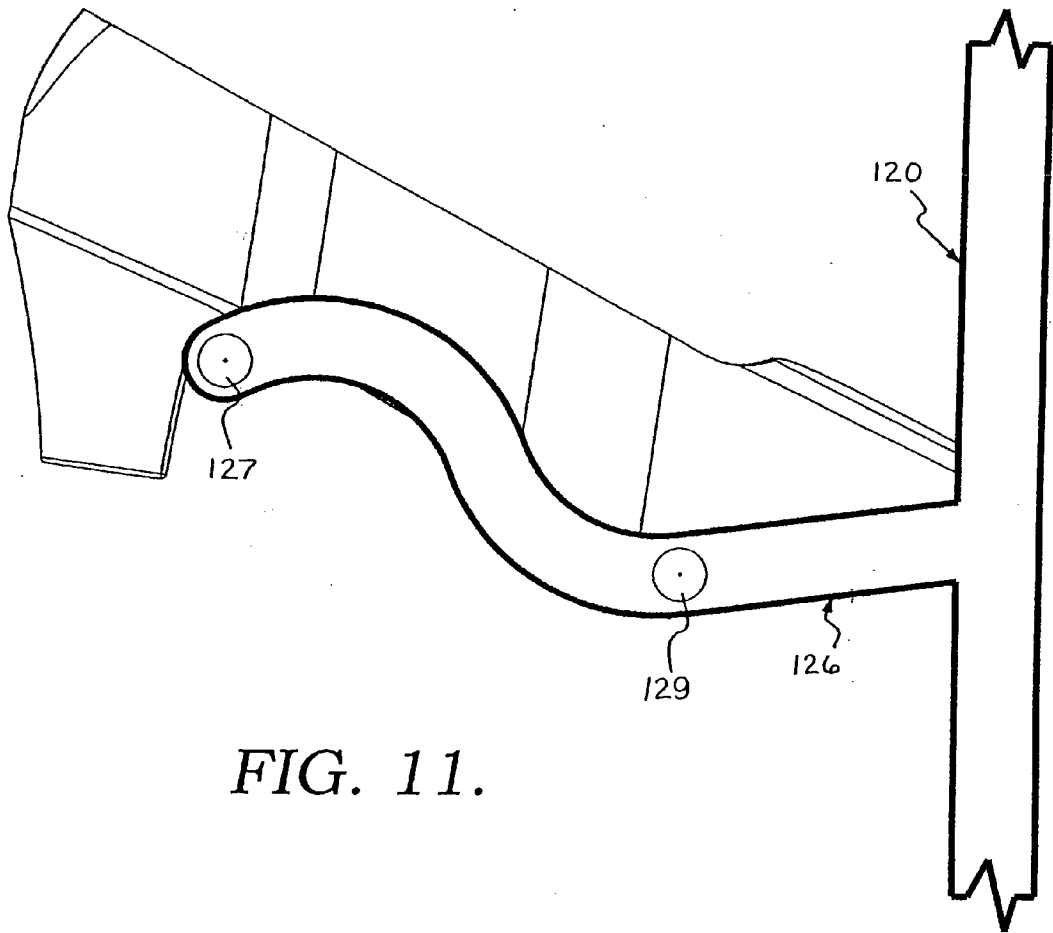

FIG. 11.

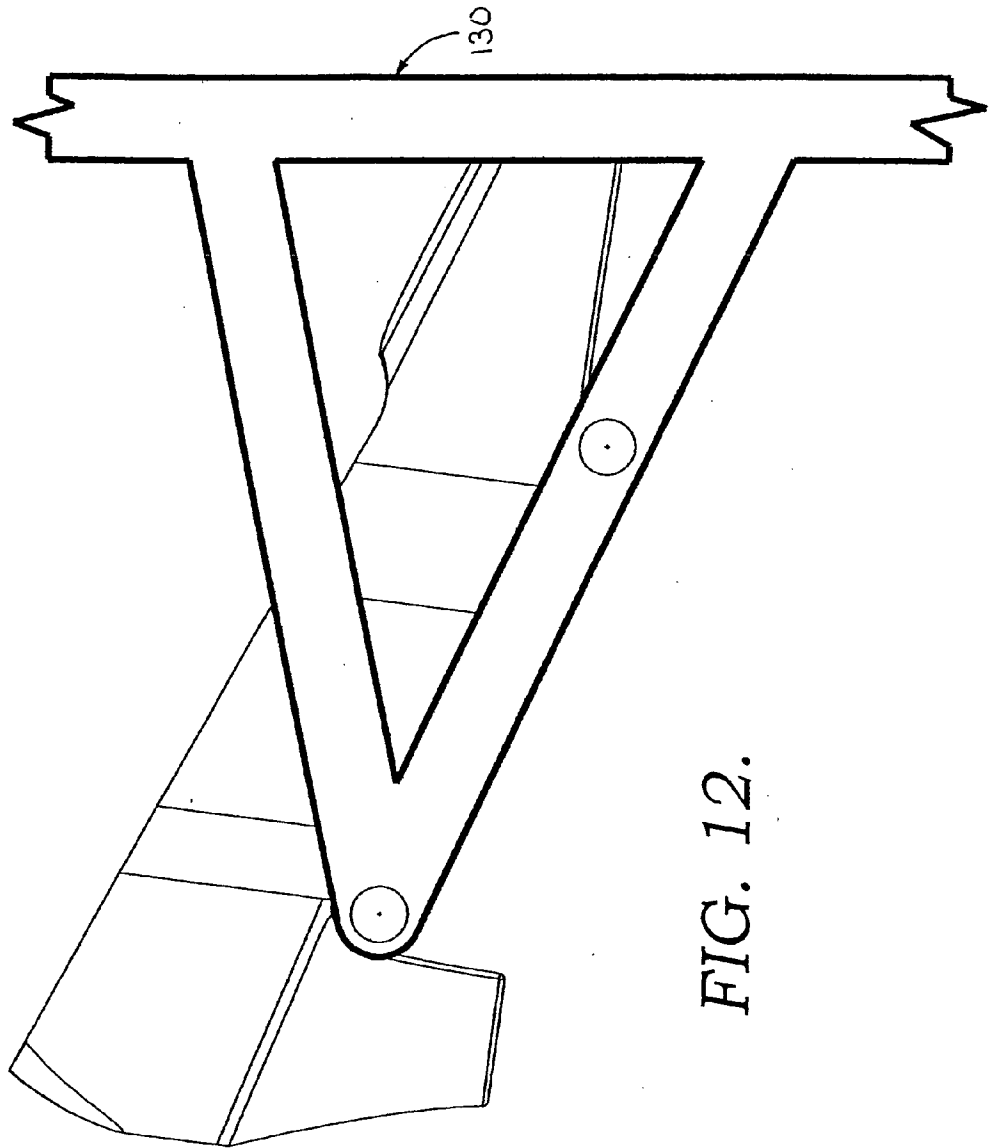

FIG. 12.

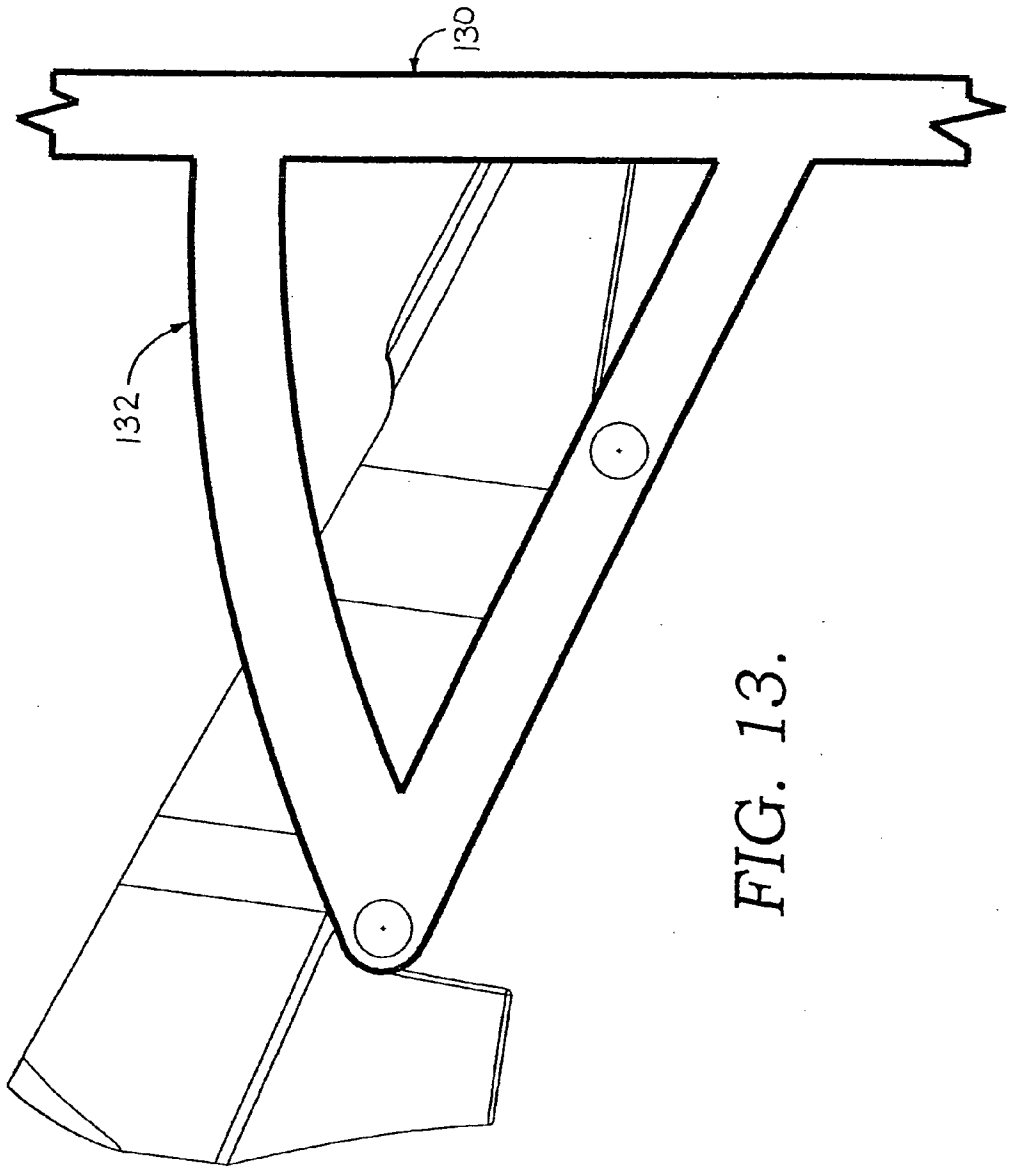

FIG. 13.

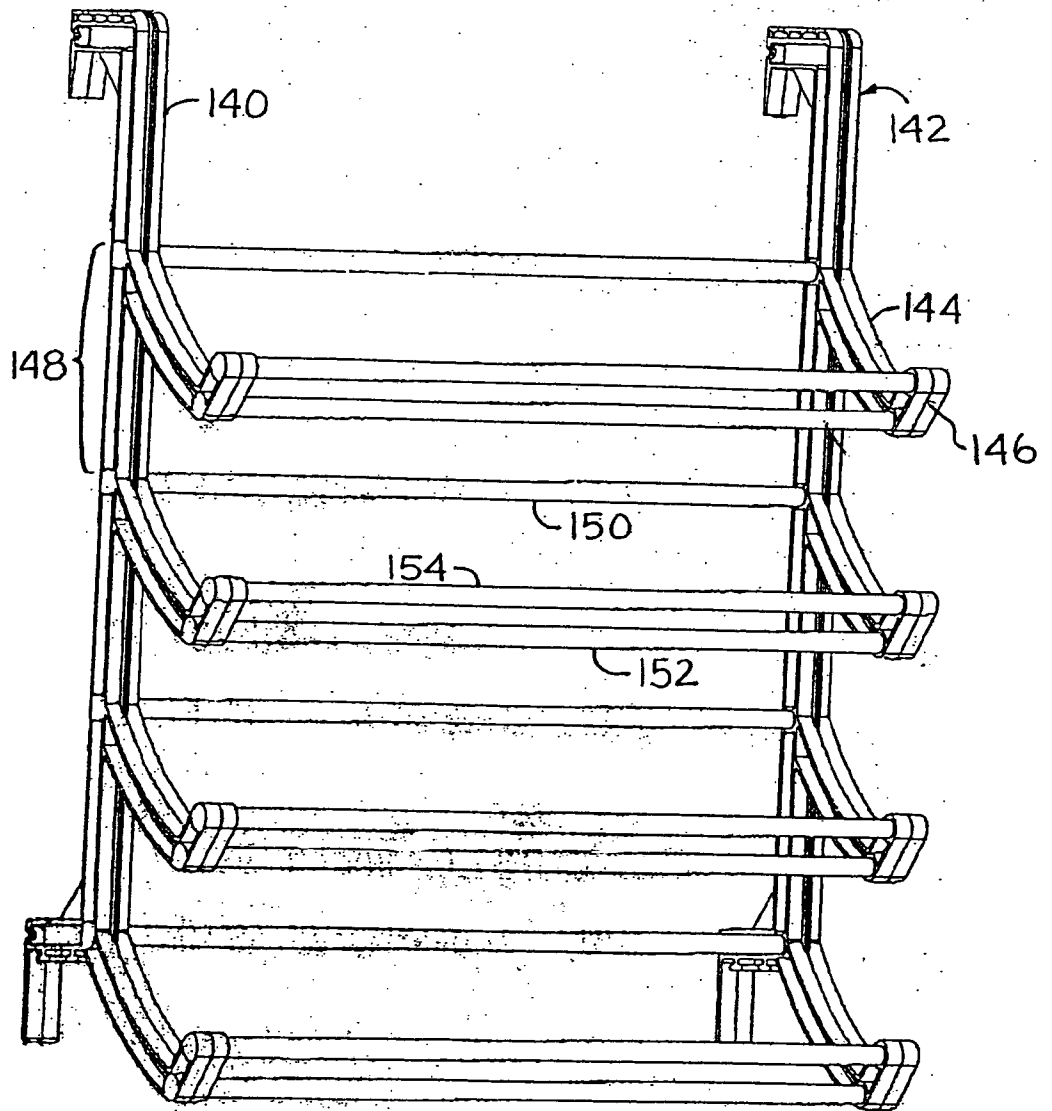

FIG. 14a.

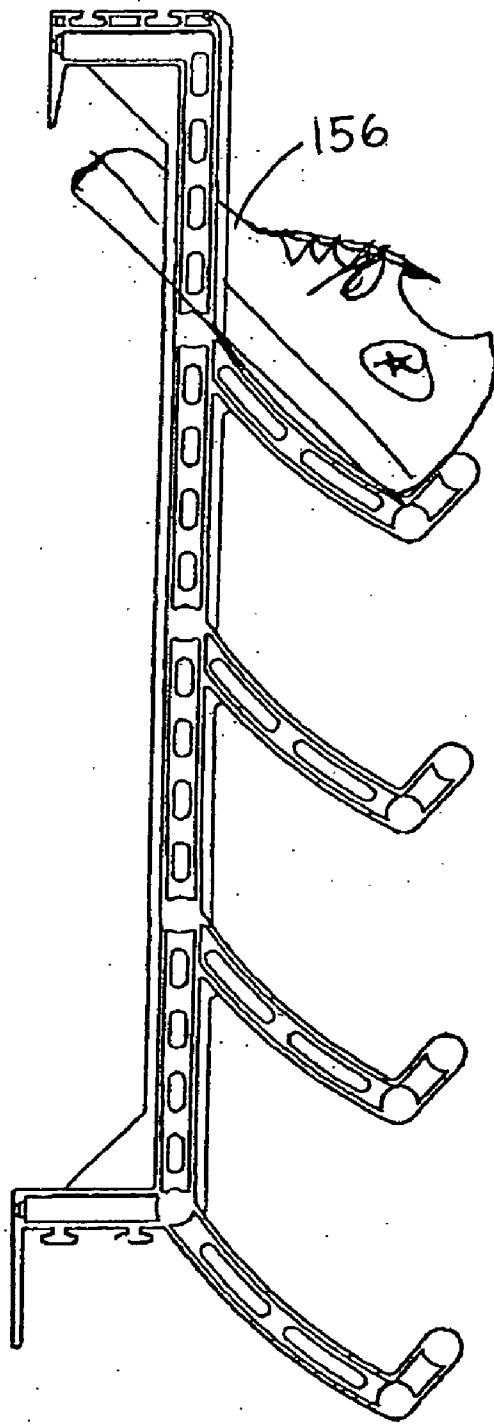

FIG. 14b.

OVER-DOOR SHOE RACKS

STATEMENT REGARDING FEDERALLY SPONSORED RESEARCH OR DEVELOPMENT

[0001] Not Applicable.

CROSS-REFERENCE TO RELATED APPLICATIONS

[0002] The present application claims priority from U.S. application Ser. No. 10/189,638, filed Jul. 3, 2002, entitled "Over-Door Shoe Racks", which is a divisional of U.S. application Ser. No. 09/641,794, filed Aug. 19, 1999 and now U.S. Pat. No. 6,533,127, issued Mar. 18, 2003, entitled "Over-Door Shoe Racks" and which claims priority from U.S. Provisional Application Serial No. 60/149,794, filed Aug. 19, 1999, entitled "Over-Door Shoe Racks".

BACKGROUND OF THE INVENTION

[0003] The present invention is generally directed to a hanging shoe rack, and is more particularly directed to a number of embodiments for shoe racks that hang from, or are positioned on, the back of the door or on another upright surface.

[0004] Hanging shoe racks are well known. For example, U.S. Pat. No. 5,695,073, entitled "Hanging Shoe Rack", is directed to a hanging shoe rack having a pair of plastic side frame members, and a plurality of support bars positioned between the side frame members on which shoes may be supported. The present invention is directed to such a product, albeit with different features. U.S. Pat. No. 5,695,073 is incorporated by reference, in its entirety, herein.

[0005] In particular, the shoe rack set forth in U.S. Pat. No. 5,695,073 includes first and second plastic side frame members. Each side frame member has as vertical member having a plurality of support arms extending outwardly and downwardly therefrom. The product has a plurality of shoe retaining bars. The shoe retaining bars are oriented in pairs, with each pair of bars aligned in a plane forming an acute angle with respect to the vertical surface on which the shoe rack is positioned. In this regard, one bar of each pair is positioned at outward ends of respective arms, while the other shoe retaining bar of the pair is positioned between the vertical members of the respective side frame members.

[0006] As illustrated best in FIG. 2 of U.S. Pat. No. 5,695,073, the vertical members of the plastic side frame members are preferably spatially removed from the upright surface or door, due to the presence of leg members at upper and lower portions of the side frame members. Hangers, or brackets, are positioned over the door and receive foot members extending downwardly from leg members, as clearly illustrated and described in the '073 patent. As illustrated and described, when the hanging shoe rack product is positioned on an upright surface, the vertical members and outwardly and downwardly depending arms serve as lateral barriers to retain the shoes on the shoe rack.

SUMMARY OF THE INVENTION

[0007] Each embodiment of the present invention is directed to a shoe rack for mounting to an upright surface, or for hanging over a door. Each embodiment of the present invention employs two plastic side frame members, and a

plurality of shoe retaining bars positioned between the side frame members, upon which shoes, boxes, and the like may be supported. However, each embodiment of the present invention incorporates different features, resulting in improved structural integrity over the prior art and/or resulting in a product that is less expensive to manufacture and/or resulting in a product which retains shoes on the shoe rack in a different, or better, manner.

BRIEF DESCRIPTION OF THE DRAWINGS

[0008] The objects and features of the invention noted above are explained in more detail with reference to the drawings, in which like reference numerals denote like elements, and in which:

[0009] FIG. 1 illustrates a first embodiment of the shoe rack of the present invention;

[0010] FIG. 2 is a fragmentary view illustrating a second embodiment of a hanging shoe rack of the present invention;

[0011] FIG. 3 is a fragmentary view illustrating a third embodiment of a hanging shoe rack of the present invention;

[0012] FIG. 4 is a fragmentary view illustrating a fourth embodiment of a hanging shoe rack of the present invention;

[0013] FIG. 5 is a fragmentary view illustrating a fifth embodiment of a hanging shoe rack of the present invention;

[0014] FIG. 6 is a fragmentary view illustrating a sixth embodiment of a hanging shoe rack of the present invention;

[0015] FIG. 7 is a fragmentary view illustrating a seventh embodiment of a hanging shoe rack of the present invention;

[0016] FIG. 8 is a fragmentary view illustrating an eighth embodiment of a hanging shoe rack of the present invention;

[0017] FIG. 9 is a fragmentary view illustrating a ninth embodiment of a hanging shoe rack of the present invention;

[0018] FIG. 10 is a fragmentary view illustrating a tenth embodiment of a hanging shoe rack of the present invention;

[0019] FIG. 11 is a fragmentary view illustrating an eleventh embodiment of a hanging shoe rack of the present invention;

[0020] FIG. 12 is a fragmentary view illustrating a twelfth embodiment of a hanging shoe rack of the present invention;

[0021] FIG. 13 is a fragmentary view illustrating a thirteenth embodiment of a hanging shoe rack of the present invention; and

[0022] FIGS. 14a and 14b illustrate a fourteenth embodiment of a hanging shoe rack of the present invention.

DETAILED DESCRIPTION OF THE INVENTION

[0023] With reference now to the figures, it is again noted that each embodiment of the present invention employs first and second side frame members, preferably made of plastic, and a plurality of shoe retaining bars oriented in pairs. Additionally, each embodiment of the present invention preferably employs components or means for mounting the shoe rack to an upright surface or for hanging the shoe rack over a door. Additionally, each embodiment of the present invention preferably is a modular shoe rack, in that one shoe

rack may be connected to another shoe rack of the invention, in a manner such as that set forth in U.S. Pat. No. 5,695,073. The following described drawings illustrate only one side frame member, or a portion thereof, since the remainder of the product will be readily understood in view of that which is disclosed herein, and that which has been incorporated herein by reference.

[0024] With reference initially to **FIG. 1**, a hanging shoe rack of the present invention has first and second plastic side frame members, with one such side frame member (a right side member) being illustrated and denoted generally by reference numeral **10**. Side frame member **10** is preferably integrally formed of molded plastic. Side frame member **10** has a primary, arcuate, or curved member, often times referred to as a main body section, denoted generally by the reference numeral **12**. Preferably, curved member **12** has an upper end, including a female socket **14**, and a lower end, including a male member **16**. As will be appreciated, one shoe rack of this embodiment of the invention can be connected to another shoe rack of this embodiment of the invention by placing the male member **16** of a first side frame member **12** in the female member **14** of a second side frame member **10**, such that one shoe rack depends from the other. Additionally, side frame member **10** preferably has a foot member **18**, which is received by a hanger such as the hanger illustrated and described in U.S. Pat. No. 5,695,073, incorporated herein by reference.

[0025] Curved side frame member **12** preferably curves downwardly from an upper portion thereof to a lower most portion, denoted by the reference numeral **20**. As illustrated, the lower most portion **20** of the side frame member is positioned outwardly from a rear portion of the side frame member **10**, such that the curved member **12** does not curve all the way back to the vertical surface. Instead, an intermediary portion **22**, which is preferably angled backwardly and upwardly, is positioned between the lower most portion **20** of side frame member **10** and a horizontal, rear member **24**, from which the male member **16** depends.

[0026] A plurality of curved support arms, denoted by reference numeral **26**, are positioned on plastic side frame member **10** and, in fact, are integrally formed therewith. The upper tiers of support arms **26**, illustrated by the uppermost two tiers of **FIG. 1**, have a first portion **28** which extends outwardly in a first direction from the curved portion **12** and a second portion **30** which extends outwardly in an opposite direction from the curved side frame portion **12**. Each arm **26** terminates in an enlarged outer end, denoted by reference numerals **32**, which have sockets therein (on a reverse side from that shown), for receiving shoe retaining bars in a conventional manner. As illustrated, a shoe **34**, when positioned on the shoe retaining bars, is retained from lateral movement both by the curvature of the support arm **26**, as well as by the curved side portion **12**. It is noted that, in the lowermost tier of shoe retaining bars, one of the sockets, denoted by reference numeral **36**, is positioned in the member **12**, as illustrated. The shoe rack illustrated in **FIG. 1** is particularly useful for preventing shoes from falling off of the shoe rack, particularly when the shoe rack is positioned on a door, such that when the door is swung from an open to closed or closed to open position, the support arms **26** and curved member **12** prevent lateral movement of the shoes. Additionally, the curved nature of member **12** distributes stress on the shoe rack, resulting from the weight of

the shoes positioned on the shoe rack, in an even or substantially even manner, thus reducing the stress points that would typically be found at an upper end of the rack.

[0027] With reference now to **FIG. 2**, an alternate embodiment is illustrated and described. Particularly, in the embodiment of **FIG. 2**, a vertical side frame member **40** is provided, with a plurality of linear support arms **42**. Each support arm has a portion thereof extending upwardly and outwardly from a first side of the vertical member **40**, and another portion thereof extending downwardly and outwardly from an opposite side of the vertical member **40**. In particular, the shoe rack is preferably positioned such that the toe **44** of the shoe **46** abuts up against the vertical surface upon which the shoe rack is mounted. Alternatively, however, the shoe rack could be constructed such that the vertical surface is positioned proximate the heel portion **48** of the shoe. The vertical member **40**, as well as the enlarged outer portions **49** of support arm **42**, prevent lateral movement of the shoe. As will be understood and appreciated, enlarged outer portions **49** have sockets (on an opposite side of that shown) for receiving shoe retaining bars.

[0028] In the embodiment of **FIG. 3**, the shoe rack again has a vertical side frame member **50**, and shoe retaining bars oriented in pairs and positioned in respective sockets **52** in enlarged outer ends **54** of corresponding support arms **56**, **58**. As illustrated, support arm **56** preferably angles outwardly and downwardly in a first direction from vertical member **50**, while support arm **58** depends outwardly and downwardly in a second direction from vertical member **50**. Thus, the arms meet at somewhat of a peak at vertical member **50**. As illustrated, the combination of vertical member **50** and arms **56**, **58** create a barrier against lateral movement of the shoe **59**.

[0029] With reference now to **FIG. 4**, the hanging shoe rack of the present invention includes a vertical side frame member **60** and a plurality of outwardly extending, curved support arms **62**. Sockets for receiving shoe retaining bars are positioned at locations **64** and **66**. As illustrated, the combination of vertical member **60** and the curved arm **62** provide a barrier against lateral movement of the shoe **68**.

[0030] With reference now to **FIG. 5**, the hanging shoe rack includes a vertical member **70** and a plurality of horizontal, outwardly extending support arm **72**. Sockets for receiving shoe retaining bars are positioned at enlarged areas **74** and **76**. It should be understood and appreciated that the shoe rack could be constructed so that the vertical surface is to the left of the page, or to the right of the page.

[0031] With reference now to **FIG. 6**, the hanging shoe rack in this embodiment of the invention has a vertical side frame member **80** and a plurality of downwardly and outwardly extending support arms **82**. The molded construction of this embodiment provides enlarged portions **84**, **86**. Sockets for receiving shoe retaining bars are preferably positioned centrally on the opposite side of enlarged areas **84**, **86**. In this embodiment, the combination of vertical member **80** and the enlarged areas **84**, **86** provide a barrier against lateral movement of the shoe **88** when positioned on the shoe rack.

[0032] In the embodiment of **FIG. 7**, the shoe rack of the present invention includes a vertical member **90**, a plurality of outwardly and upwardly angled support arms **92**, and a

horizontal barrier arm **94**, positioned as shown. Shoe retaining bars are positioned in sockets at enlarged locations **96** and **98**. The shoe **99** is retained on the bars primarily by the combination of vertical member **90** and barrier arm **94**, and to a lesser degree by the angled support arms **92**.

[0033] In the embodiment of **FIG. 8**, the hanging shoe rack of the present invention includes a vertical member **100**, and a plurality of outwardly and upwardly angled support arms **102**. Sockets for receiving shoe retaining bars are positioned at enlarged areas **104** and **106**. A particular aspect of this embodiment is the provision of tabs **108** positioned at an upper portion of support arm **102**. As illustrated, the combination of vertical member **100** and tabs **108** provide a barrier against lateral movement of shoe **109**.

[0034] In an alternative embodiment of **FIG. 8**, **FIG. 9** has a similar vertical member **100**, an angled support arm **102**, with socket areas **104**, **106**. However, instead of the tabs **108** previously described, a loop portion **107** is presented for providing an additional lateral barrier. While the loop portion **107** is preferably formed of molded plastic, it could also be formed of another suitable material, such as wire. In the case where the loop **107** is formed of wire, it is potted into the molding compound used for forming the support arm **102**.

[0035] In the embodiments of **FIGS. 10 and 11**, a vertical support member **120** is provided. In the embodiment of **FIG. 10**, vertical support member **120** is positioned outwardly from an upright surface upon which the shoe rack is mounted. In this regard, the shoe rack is preferably mounted such that the toe portion **122** of the shoe **124** abuts up against the upright surface. In contrast, in the embodiment of **FIG. 11**, the vertical portion **120** preferably abuts up against the upright surface.

[0036] In each embodiment, a support arm **126** is provided. In a particular aspect of these embodiments, support arm **126** is curved in an "S-curve". In the embodiment of **FIG. 10**, the socket areas **127**, **128** are positioned as shown, with the socket **128** being in the vertical member **120**. In contrast, in the embodiment of **FIG. 11**, each socket area **127**, **129** is on the support arm **126**.

[0037] As illustrated, the precise nature of the "S-curve" arm **126** is different in each embodiment, with different dimensions at different angles. It will be understood and appreciated that variations of this S-curve feature may be made without departing from the spirit and scope of the invention.

[0038] The embodiments of **FIGS. 12 and 13** are similar to the embodiment of **FIG. 7**, with the exception that the vertical member **130** is positioned in abutment against the upright surface. Further, as illustrated in the alternative embodiment shown in **FIG. 13**, the barrier arm **132** may be

curved or arcuate rather than horizontal as shown in **FIGS. 7 and 12**. As can be seen in both **FIGS. 12 and 13**, only the dimensions and appearance of the product have changed, but each serves the purpose of preventing lateral movement of the shoes.

[0039] The embodiment of **FIGS. 14a and 14b** have first and second side frame members **140**, **142**, each having a number of support arms **144** angled outwardly and downwardly therefrom. Each support arm **144** has an angled portion **146** at an outer end thereof. As illustrated, the hanging shoe rack of this embodiment has a number of shoe retaining tiers **148**. Each tier **148** has a first bar **150** a second bar **152** and a third bar **154**, positioned as shown. In particular, bars **152**, **154** form a parallel pair of bars for retaining shoes in a tilted manner as illustrated in **FIG. 14b**, such that the shoes are angled upwardly toward the surface upon which the shoe rack is mounted or positioned.

[0040] From the foregoing it will be seen that this invention is one well adapted to attain all ends and objects hereinabove set forth together with the other advantages which are obvious and which are inherent to the structure.

[0041] It will be understood that certain features and subcombinations are of utility and may be employed without reference to other features and subcombinations. This is contemplated by and is within the scope of the claims.

[0042] Since many possible embodiments may be made of the invention without departing from the scope thereof, it is to be understood that all matter herein set forth or shown in the accompanying drawings is to be interpreted as illustrative, and not in a limiting sense.

What is claimed is:

1. A shoe rack for hanging on an upright surface, said shoe rack comprising:

first and second opposed, side frame members, each said side frame member having a main body section and a plurality of support arms projecting outwardly therefrom and terminating in free ends displaced from said side frame members; and

a plurality of shoe-retaining bars, extending between said side frame members, for retaining shoes, wherein said shoe-retaining bars are oriented in tiers, such that each tier has a first bar, a second bar and a third bar, wherein said first bar is located higher and closer to said upright surface than said second and third bars, and wherein at least said second and third bars are located on said projecting support arms and form a parallel pair of bars located on said free ends of said arms, whereby a shoe resting on a said tier is angled upwardly toward said upright surface and engages all three of said bars.

* * * * *