

(19) World Intellectual Property Organization
International Bureau



(43) International Publication Date
24 February 2005 (24.02.2005)

PCT

(10) International Publication Number
WO 2005/018249 A1

- (51) International Patent Classification⁷: **H04Q 3/00**, H04L 12/24
- (21) International Application Number: PCT/IT2003/000511
- (22) International Filing Date: 19 August 2003 (19.08.2003)
- (25) Filing Language: English
- (26) Publication Language: English
- (71) Applicant (for all designated States except US): **TELECOM ITALIA S.p.A.** [IT/IT]; Piazza degli Affari, 2, I-20123 Milano (IT).
- (72) Inventors; and
- (75) Inventors/Applicants (for US only): **COVINO, Giuseppe** [IT/IT]; Telecom Italia S.p.a., Via G. Reiss Romoli, 274, I-10148 Torino (IT). **GOTTA, Danilo** [IT/IT]; Telecom Italia S.p.A., Via G. Reiss Romoli, 274, I-10148 Torino (IT). **UGHETTI, Marco** [IT/IT]; Telecom Italia S.p.A., Via G. Reiss Romoli, 274, I-10148 Torino (IT).
- (74) Agents: **MARKOVINA, Paolo** et al.; Pirelli & C. S.p.A., Viale Sarca, 222, I-20126 Milano (IT).

- (81) Designated States (national): AE, AG, AL, AM, AT, AU, AZ, BA, BB, BG, BR, BY, BZ, CA, CH, CN, CO, CR, CU, CZ, DE, DK, DM, DZ, EC, EE, ES, FI, GB, GD, GE, GH, GM, HR, HU, ID, IL, IN, IS, JP, KE, KG, KP, KR, KZ, LC, LK, LR, LS, LT, LU, LV, MA, MD, MG, MK, MN, MW, MX, MZ, NI, NO, NZ, OM, PG, PH, PL, PT, RO, RU, SC, SD, SE, SG, SK, SL, SY, TJ, TM, TN, TR, TT, TZ, UA, UG, US, UZ, VC, VN, YU, ZA, ZM, ZW.
- (84) Designated States (regional): ARIPO patent (GH, GM, KE, LS, MW, MZ, SD, SL, SZ, TZ, UG, ZM, ZW), Eurasian patent (AM, AZ, BY, KG, KZ, MD, RU, TJ, TM), European patent (AT, BE, BG, CH, CY, CZ, DE, DK, EE, ES, FI, FR, GB, GR, HU, IE, IT, LU, MC, NL, PT, RO, SE, SI, SK, TR), OAPI patent (BF, BJ, CF, CG, CI, CM, GA, GN, GQ, GW, ML, MR, NE, SN, TD, TG).

Declarations under Rule 4.17:

— as to applicant's entitlement to apply for and be granted a patent (Rule 4.17(ii)) for the following designations AE, AG, AL, AM, AT, AU, AZ, BA, BB, BG, BR, BY, BZ, CA, CH, CN, CO, CR, CU, CZ, DE, DK, DM, DZ, EC, EE, ES, FI, GB, GD, GE, GH, GM, HR, HU, ID, IL, IN, IS, JP, KE, KG, KP, KR, KZ, LC, LK, LR, LS, LT, LU, LV, MA, MD, MG, MK, MN, MW, MX, MZ, NI, NO, NZ, OM, PG, PH,

[Continued on next page]

(54) Title: SYSTEM ARCHITECTURE METHOD AND COMPUTER PROGRAM PRODUCT FOR MANAGING TELECOMMUNICATION NETWORKS

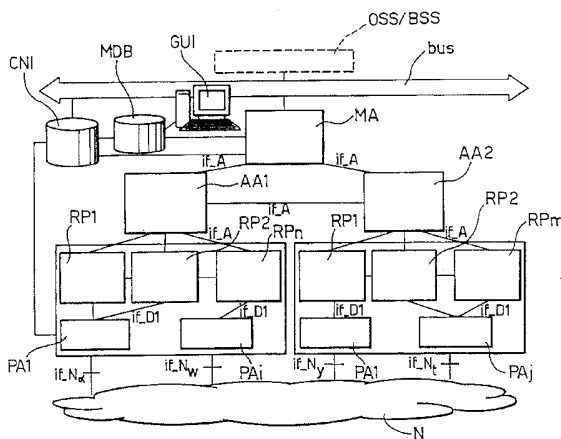

(57) Abstract: A system architecture for managing a telecommunication network (N) including network equipments and supported network services, wherein the equipments have associated control interfaces (if_{N α} , if_{N w} , if_{N y} , if_{N i}). The architecture comprises - a base layer (RA, RP) proxying the interfaces (if_{N α} , if_{N w} , if_{N y} , if_{N i}) and decoupling them from management functions, and - a support layer (AA) comprised of a community of agents co-ordinating operation of said base layer (RA, RP) in order to support distributed management functionalities. The base layer and the support layer constitute separated superposed layers in the architecture. The layers (PA, RP; AA; MA) in the architecture preferably include components adapted to perform respective functions based on respective instruction information provided to them. A data base (MDB) is provided storing the instruction information and the architecture being is arranged for distributing the instruction information from the data base (MDB) to the components. Preferably, all the layers in the architecture include process executors (PE).

WO 2005/018249 A1



PL, PT, RO, RU, SC, SD, SE, SG, SK, SL, SY, TJ, TM, TN, TR, TT, TZ, UA, UG, UZ, VC, VN, YU, ZA, ZM, ZW, ARIPO patent (GH, GM, KE, LS, MW, MZ, SD, SL, SZ, TZ, UG, ZM, ZW), Eurasian patent (AM, AZ, BY, KG, KZ, MD, RU, TJ, TM), European patent (AT, BE, BG, CH, CY, CZ, DE, DK, EE, ES, FI, FR, GB, GR, HU, IE, IT, LU, MC, NL, PT, RO, SE, SI, SK, TR), OAPI patent (BF, BJ, CF, CG, CI, CM, GA, GN, GQ, GW, ML, MR, NE, SN, TD, TG)

— of inventorship (Rule 4.17(iv)) for US only

Published:

— with international search report

For two-letter codes and other abbreviations, refer to the "Guidance Notes on Codes and Abbreviations" appearing at the beginning of each regular issue of the PCT Gazette.

SYSTEM ARCHITECTURE, METHOD AND COMPUTER PROGRAM PRODUCT FOR MANAGING TELECOMMUNICATION NETWORKS

Field of invention

5 The invention relates to architectures for managing telecommunication networks and to services and tools for use in those architectures.

Description of the related art

10 In conventional arrangements, management of telecommunication networks is carried out via separate systems/functionalities currently referred to as FCAPS (an acronym for Fault, Configuration, Accounting, Performance, Security). These are generally separate components exhibiting both poor flexibility and low
15 scalability. Stated otherwise, in conventional arrangements, any addition/modification in the network managed entails corresponding additions/modifications to be carried out in each of the FCAPS.

20 Distributed network management platforms have thus been proposed in recent times that essentially implement multi-level hierarchical architectures of components (oftentimes called agents) and single-layer architectures.

25 For instance, US-A-6 243 396 proposes a multi-layer architecture of authorities that includes agents. These agents are specialized for the various FCAPS functionalities as well as for representing network resources (proxy). This approach is quite flexible but fails to be truly satisfactory as regards the need of
30 precisely identifying functionalities in the different layers and to avoid excessively layered structures likely to give rise to control and interfacing

complexity. In brief, US-A-6 243 396 does describe distributed and hierarchical agents exchanging goals. However, layers are not specified in their functions.

Another approach, involving a "flat" architecture, 5 is disclosed in US2002/0032769 A1 and the corresponding EP-A-1 150 454. There, a network management system is disclosed that provides distributed task and data processing services by employing distributed autonomous agents. Specifically, the arrangement disclosed in 10 these two parallel documents provides for certain components (again autonomous agents) holding a distributed representation of the network (proxy function) and support distributed FCAPS functionalities. This kind of architecture improves 15 scalability but does not reach a truly satisfactory degree of flexibility. The proxy function and the management function are intrinsically intertwined with each other and some functionalities turn out to be difficult to implement efficiently in a distributed 20 manner.

More generally, certain prior art network management platforms implement flexibility in the form of more or less sophisticated configuration capabilities and/or by offering development 25 environments that help system designers or integrators to build the skeleton of new modules to support new services or new technologies.

This common degree of flexibility is known not to be satisfactory; arrangements have thus been proposed 30 (see e.g. the TMF program designated NGOSS described e.g. in "NGOSS Technology Neutral Architecture", document TeleManagementForum TMF053 release 3.0, April 2003) wherein extraction of business process logic from components is recommended in order to have an external

process engine that can orchestrate the flow of actions achieving a greater flexibility.

Process engines have also been proposed for use as workflow coordinators in distributed components each offering specific functionalities: see for example WO-A-01/02973 where the possibility is demonstrated of using a centralized workflow engine for coordinating distributed agents.

This approach improves flexibility only to a partial extent: a centralized process manager can become a bottleneck while a good deal of process logic remains embedded in the single components. This makes it impossible to concentrate in a process engine the functional aspects of all the components.

15 Object and summary of the invention

The object of the present invention is thus to dispense with the intrinsic disadvantages of the prior art arrangements considered in the foregoing.

According to the invention, that object is achieved by means of system architecture having the features set forth in the claims that follow. The invention also relates to a corresponding method as well as computer program products loadable in the memory of at least one computer and comprising software code portions for performing the method of the invention. Reference to "at least one computer" is evidently intended to highlight the suitability for decentralized implementation of at least part of the arrangement of the invention.

30 The arrangement described herein specifies a new platform for the distributed management of a telecommunication network and the services supported

thereby as well as a manner for rendering the components very flexible and scalable.

The arrangement described herein solves the problems intrinsic in prior art arrangements by offering both centralized and distributed functionalities with agents arranged in a specific hierarchical structure by assigning precise functions to each layer. For instance, in a three-layer architecture each layer will have a specific task: a first layer will support centralized/coordination functionalities, the second layer will support the distributed functionalities and the third layer proxies the network with the aim of decoupling network interfaces from management functions.

The degree of flexibility of such an arrangement may be further improved by resorting to specific tools. These may involve, e.g.:

a) using combinations of workflow engines and rule engines in the components in all layers by establishing a distributed and hierarchical structure of workflow plus rule engines; the components will thus be fully "teachable" in terms of functionalities;

b) defining a model data base (MDB) that stores all process (workflows and rules) and data model definitions; this will provide a single point where the functions of the platform components will be defined in a centralized manner;

c) taking advantage of a) and b) by automatically distributing process and data model definitions across the platform; this will avoid the need of synchronizing the distributed hierarchical structure of engines.

The administrator of the platform will thus be in a position to generate any FCAPS functions by defining them in the data base, while the components involved will "learn" the new process definitions (workflow and 5 rules) and run them when needed.

These processes can cover any FCAPS functionality, thus evolving from current platforms where each component runs a specific domain functionality (assurance, provisioning, performance, etc.) to 10 platforms where each component can be freely "focused" (possibly run-time) on specific domain functionalities as required by current policies, availability of resources, load status, and so on.

The use of process engines does in fact boost the 15 capabilities of a proxy layer as disclosed in EP-A-1 150 454. Extensive standardization activities on equipment models during the years (see e.g. the Common Information Model [CIM] technical note, DMTF, January 2003 or the "Shared Information Data Model 20 Specification", document TeleManagementForum GB922 release 3.0, April 2003) have attempted to define flexible and extendible models. The arrangement described herein further develops these models by enabling modifications of those models without changing 25 the code in the proxy.

By way of summary, the arrangement disclosed herein provides a fully satisfactory answer to five major issues that affect current platforms:

- a higher flexibility in supporting new services 30 and modifications of existing services;
- a higher flexibility in supporting new network technologies including new types of equipment;

- higher and easier distribution of applications through code mobility;

- improved (e.g. more complete and real-time) alignment of network inventory with network status; and

5 - improved scalability and performance control of the new network and service management platform.

Significant and preferred architectural points in the presently preferred embodiment of the invention are the following:

10 - network and service management platform is provided based on distributed agents running 3-layer hierarchical workflow and rules engines;

- workflows and rules are used for not just coordinating of applications but also for implementing
15 all the behavioral aspects of the components in the platform;

- a centralized model inventory (MDB) is made available for the definition and master storage of all process descriptions and network resource information
20 models. These definitions are then distributed throughout the platform for use in the process engines that achieve automatic synchronization of all operating functionalities of the platform; the need is thus satisfied of having updated documentation of equipment
25 modeling and operating processes continuously available; and

- a distributed network inventory layer (proxy) is provided that decouples the equipment from the operation support system (OSS) providing a fully
30 synchronized database for all processes that need real-time documentation of the network.

Brief description of the annexed drawings

The invention will now be described, by way of example only, with reference to the annexed figures of drawing, wherein:

- 5 - figure 1 is a block diagram showing the overall architecture of the arrangement shown herein,
- figure 2 is a block diagram showing a related provisioning scenario,
- figure 3, including two portions indicated a)
10 and b), respectively, shows various examples of multilevel workflows,
- figure 4 depicts a typical activity diagram of an arrangement disclosed herein,
- figure 5 is an example of certain layer
15 processes in the arrangement disclosed herein,
- figure 6, again including two parts designated a) and b), respectively, portrays various examples of multilevel workflow with exemplary rules for fault management,
- 20 - figure 7 shows another activity diagram within the framework of the arrangement disclosed herein,
- figure 8 portrays another scenario likely to arise within the framework of the arrangement described herein,
- 25 - figure 9 portrays an exemplary use case of an arrangement disclosed herein,
- figure 10 is a flow chart of workflows occurring within the arrangement disclosed herein, and

- figure 11 is another activity diagram related to the arrangement described herein.

Detailed description of preferred embodiments of the invention

5 In order to facilitate proper understanding of the principles underlying the invention, a number of basic definitions will now be provided of certain terms as used in describing the arrangement disclosed herein.

Agent: an agent is an independent and autonomous
10 process with possible persistent state and requiring communication (e.g. collaboration or competition) with other agents in order to fulfill its tasks. This communication may be implemented through asynchronous message passing and by using well known languages (i.e.
15 Agent Communication Language or ACL) with a well-defined and commonly agreed semantics.

Element Manager: in a network management environment this is an application that manages a number of network elements. Typically, the element
20 manager is developed by the network element vendor and includes functionalities like: configuration, alarm monitoring and service provisioning.

OSS (Operations Support System): in a network management environment this is the application that is
25 in charge of running tasks like trouble ticketing, billing, order management. Typically OSSs support the service and network management applications.

Network and service inventory: this is the system that stores and makes inventory information available
30 to the other OSSs or management applications. The inventory information may include network and computing equipment, logical resources, topology and services.

This (sub)system keeps track of the physical and topology configuration of the network, equipment inventory (cards, ports, etc.), physical and logical connectivity of the different network layers. A portion
5 of the inventory, usually called "catalog", holds the descriptions of all entities stored in the inventory, both services and network entities. The Inventory keeps also track of planned, subscribed and provisioned services. Services are associated with the logical and
10 physical network resources.

Manager application: this is an application running on a host and adapted to co-ordinate operation of one or more agents. It may include a graphical user interface (GUI) and is adapted to communicate with the
15 distributed agents. For instance, it may distribute workflows, call the distributed agents to invoke an operation on a managed resource and perform administrative tasks.

Information model: this is the collection of
20 information related to all managed objects. This information is preferably arranged in information types (or categories), each of these being in turn related to a given type of managed object (e.g. a personal computer, and so on). A managed object is one of any
25 number of specific characteristics of a managed device. In a network management environment, managed devices are network elements and managed objects are entities like: cards, ports, physical and logical connections etc.

30 Proxy: a proxy object is a component mediating control of access to the actual object, for example a network element, on which a functionality lies.

Rule engine: a rule engine is a system for separating business rules (logically and/or physically) from the control logic and sharing them across data stores, user interfaces and applications. Once the
5 rules are separated out and shared, the rule engine allows the users to modify them without making changes to other application modules. A rule engine is basically a sophisticated if/then statement interpreter. The if/then statements that are
10 interpreted are called rules. The 'if' portions of the rules contain conditions such as 'item.price > \$100'. The 'then' portions of the rules contain actions such as "recommendDiscount(5%)'. The inputs to a rule engine are a rule set and some data objects. The outputs from
15 a rule engine are determined by the inputs and may include the original input data objects with possible modifications, new data objects and side effects. A rule engine is used to decide, at runtime, which rules apply and how these are to be executed.

20 Workflow: a workflow is essentially the full or partial automation, e.g. of a business process, where documents, information or tasks are passed from one participant to another for action, according to a set of procedural rules. A workflow can be represented
25 through a flowchart with a sequence of tasks and temporal and logical dependencies between tasks including alternative or parallel branches. A workflow can also be described as a finite state machine or with descriptive languages such as XPDL (XML Process
30 Description Language).

Workflow engine: a workflow engine is the component in a workflow automation program that possesses all the information related to the procedures, steps in a procedure, and the rules for

each step. The workflow engine determines whether the process is ready to move on to the next step. Briefly stated, a workflow engine is a component adopted for executing workflows.

5 As shown in the diagram of figure 1, the arrangement disclosed herein is based on an architecture including various types of components, namely:

- a collection of sets of resource proxies RP1,..., RPn; RP1..., RPm with associated protocol adapters PA1,...PAi; PA1,...Paj,
- a collection of agent applications AA1,... AA2,
- a (logical) manager application - MA,
- centralized network inventory - CNI, and
- 15 - a model data base MDB.

As better detailed in the following, the architecture in question (or platform) is adapted for managing a telecommunication network N including network equipments (not shown in detail but of any
20 known type).

These equipments have associated control interfaces such as those indicated as if_{N α} , if_{N w} , if_{N y} , if_{N t} in figure 1.

The resource proxies RP1,..., RPn; RP1..., RPm and
25 the associated protocol adapters PA1,...PAi; PA1,...Paj essentially comprise a base layer that proxies the interfaces if_{N α} , if_{N w} , if_{N y} , if_{N t} by decoupling them from management functions.

The agents AAs in turn comprise a community of
30 agents that co-ordinate operation of the base layer (RA, RP) in order to support distributed management functionalities.

The base layer and the support layer constitute separated superposed layers in the architecture.

The data base MDB is the single (logical) point of definition and storage of all the behavioral and functional aspects of the platform, workflows, rules, information models and schemes. The platform automatically distributes these definitions to the platform components. The model data base is strictly linked to the catalog part of the network inventory system.

Being the source of all process and common data definition the MDB data base is inherently synchronized with the functionalities offered by the different components and the information models used to represent resources and services. This represents a major asset for the architecture operator who is not required to retrieve information from a huge amount of documentation provided by the different component vendors with the risk of failing to be aligned with all the operating components.

In the embodiment shown, processes are segmented into three layers with specific functions. This choice is intended to meet two needs: having the lowest possible number of layers (thus avoiding the complexity of conventional architectures) and allowing free allocation of processes between a distributed and a centralized implementation.

That implies the presence of a centralized layer 1 (that corresponds to the manager application MA), a fully distributed support layer 2 (that corresponds to the agent applications - hereinafter, briefly, AAs) plus one independent proxy layer 3 that decouples the network from the management platform. This segmentation also enables the provision of different service views,

for example a business view by layer 1, a fulfillment view by layer 2 and an engineering view by layer 3. It will be appreciated that referring to the manager application MA and the layer comprised of the agent applications AAs does not exclude the possibility that the respective components may be at least partially arranged at the same geographical location.

Protocol adapters (hereinafter, briefly, PA) are typically arranged in sets, each set being responsible for interfacing all the network equipments of a designated area that offer the same application programming interface (API) protocol, for example SNMP (Simple Network Management Protocol), Telnet, TL1, etc. Each PA offers, as a service rendered to the resource proxies RP, execution of basic operations on the equipment; example of services for a SNMP protocol adapter are: `get(parameters)`, `set(parameters)`.

Each resource proxy (hereinafter, briefly, RP) is responsible for creating, maintaining and managing a so called "image" of a single equipment in the network N. The image is a representation of the configuration of the equipment according to a defined information model.

The alignment of the image to the network is effected in the following way:

- 25 - all the actions that the management platform performs on the network are actually done by RPs invoking operations through appropriate PAs;
- all the notifications (like alarms, traps) sent by the equipments are received by the proxies; that does not prevent equipments from sending notifications also to other destinations;
- 30 - periodic verification of alignment between the image of the equipment and the equipment itself is performed by the resource proxies (RPs).

The single equipment image can be enriched by element manager (EM) information such as e.g. inter-equipment information like topology, to give end-to-end view of services scattered across multiple equipments, and other information available on the EM.

Each RP runs processes typical of RP level using a process executor (PE): these processes may be defined "layer 3" processes and can be structured in sublayers. Processes at the top of layer 3 can be invoked externally, thus they are the services that each RP offers to the associated agent application(s) and to external applications. They represent the operations that can be performed atomically (thus as a single transaction) on the equipment that the RP manages.

Examples of services offered by the RP are: configure port, create cross-connection, modify connection attribute; each of these can include sequences of basic commands to be sent and/or received to/by the equipments.

Processes at the bottom of layer 3 use services offered by PAs. An example of a "layer 3" process is shown in figure 5.

The image handled by a RP is dynamically defined by the information model of the represented resource (e.g. a given network equipment). This model is defined by the GUI interface, stored in the data base MDB, then distributed by the manager application to the RPs. These load the model and finally instantiate it with values retrieved by the resource. Again the instantiation is performed in a flexible way using the PE.

In this manner changes and additions of information models (like version upgrade, new equipment introduction) do not require any appreciable software

change in the platform components. This achieves a high degree of flexibility, insofar as the equipment API protocol is supported by the PA. Very slow evolution of protocols (SNMP, telnet) compared with high performance 5 required from PAs makes using PE to implement PAs a less preferred choice.

As a fundamental component of the management platform, the network inventory CNI is arranged in two parts, namely: a distributed network inventory (DNI) 10 and a centralized network inventory (CNI).

The former (i.e. the DNI) is the collection of all virtualizations (images) contained in all the RPs; it is used for all real-time or almost real-time tasks as provisioning, assurance, performance, control, and so 15 on, where updated information on the configuration and state of the network is necessary for the accuracy and effectiveness of the task. These real-time tasks are difficult to perform by relying upon a logically centralized database, as is the case in current 20 implementations of network inventory.

The latter part (i.e. the CNI) corresponds to the usual concept of a network inventory component. It is used for non real-time tasks where continuous updates are not possible for a centralized architecture. 25 Example of such tasks are network design, network planning, capacity trend analysis.

The centralized network inventory is periodically updated retrieving information from the RPs.

Proxies can interact with one another directly for 30 jobs that require simple inter-working. For example, in order to set up an end-to-end path, a given AA can use the topology information (which equipment is connected to which other) stored in the respective RPs.

Each AA is responsible for coordination of a respective set of RPs and for the execution of processes typical of the agent layer by using a PE. These processes must be executed in a distributed way
5 and can be structured in sub-layers. Processes at the top of this "layer 2" can be externally invoked; thus these are the services that an AA offers to the manager application MA. These services are characterized by being vendor and technology independent, for example
10 "create a DSL service", resulting into different sequences of actions whether the network technology is ADSL or VDSL and whether the vendor is vendor XX or vendor YY. Processes at the bottom of layer 2 use services (that is, invoke processes) offered by RPs.

15 Each AA does not require software update to support new services and technologies. This is due to the flexibility of the processes that are received by the manager application MA, loaded and executed by the AA layer.

20 AAs interact with one another via a community protocol (a messaging passing mechanism) to support distributed execution of management functionalities, for example distributed circuit design.

Each AA is responsible for local performance
25 monitoring in order to inform the manager in respect of performance status.

The manager application MA is responsible for the following tasks:

- managing the distribution of processes and the
30 related information models of "layer 2" and "layer 3" from the MDB data base to the various AAs and RPs by retrieving the process definitions from the MDB data base;

- monitoring the state of the platform with information provided by the AAs (and possibly the RPs), including distribution of components, domain management (partitioning of the whole network among the AAs),
5 performance monitoring and consequent actions like re-distributing load among the AAs in order to achieve proper load balance;

- interactions with external systems, like other operation support systems (OSSs) and billing support
10 systems (BSSs);

- execution of processes typical of the manager layer (as better detailed in the following).

Processes of such "layer 1" can be arranged in sub-layers and are characterized in order to provide
15 functionalities that require interaction with external entities (other than AAs) or coordination among agents that cannot easily or efficiently be performed in a distributed way by AAs. The great flexibility of the architecture permits smooth evolution: for example,
20 enhancement of the community protocol may enable migration of a process from layer 1 to layer 2.

Process executors for any layer are intended to be a workflow (a flowchart), a rule engine, or a combination of the two. For example, a provisioning
25 process is better represented as a workflow while an alarm correlation is better represented as a combination of rules. This combination enables the administrator of the platform to set up any FCAPS functionality and let it evolve with a high degree of
30 flexibility. Whenever possible and advisable, using workflows is preferred as this avoids the complexity of dealing with rule conflicts and rule management.

The process engines are embedded within the MAs, AAs and RPs; in fact an external location would entail

remote invocations likely to produce performance degradations.

The various MAs, AAs and RPs show both a reactive and a proactive behaviour, as they are triggered on 5 events but may also start processes.

Each of the AAs and the RPs as well as the MA can support any FCAPS functionality. That enables task-customization of components and reallocation based on task priority and resource needs, e.g. by allotting a 10 majority of agents during daytime to service provisioning and a majority of agents during nighttime to network optimization.

Agent mobility is useful to move agent among machines in order to solve agent deployment as well as 15 fault tolerance issues. If for any reason an agent "goes down", a new agent can be instantiated and moved toward another running machine in order to replace the non-available agent. The MA periodically monitors the presence of AA agents; if any of these "goes down" then 20 MA may activate agent "resurrection" through mobility.

Agent mobility is also useful in order to move agents among machines in order to solve load balancing problem. This can occur when, for instance, an AA continuously checked by a MA to run a process, e.g. an 25 ADSL activation process, becomes a bottleneck leading to operation slowdown. A new AA agent can be instantiated and moved either toward the machine where the overloaded AA agent runs (in order to distribute process invocations coming from the MA) or toward a 30 machine with a lower CPU load.

The AA agent communicates the current load conditions to the MA, after which the MA executes the actions required e.g. by implementing agent mobility.

The MA thus decides whether agents are to be moved or not, in order to keep control of agent dissemination.

The architecture described is thus intrinsically adaptive and can detect and predict saturation.

5 A preferred embodiment of the arrangement described herein uses JADE (Java Agent DEvelopment framework) for implementing agents with mobility features, the SID model (cited in the introductory portion of this description) to define the common
10 model, BPML (Business Process Modeling Language) for process definition, and JESS (Java Expert System Shell) for PE implementation.

As a first example a three-layered provisioning scenario can be considered.

15 Specifically, figure 2 depicts the setup of a service provisioning scenario showing the achieved flexibility and scalability.

A broadband service "Offer 1" shall be delivered in a TLC network that includes access devices (ex. ADSL
20 Equipment ADSL E), an ATM backbone and one or more broadband access servers BAS in order to achieve IP connectivity.

AA1, AA2, AA3 are the agents that manage, respectively:

25 - the resource proxy RP1 that represents the image of the ADSL Equipment (i.e. the endpoint A of the end-to-end circuit),

- the resource proxy RP2 that represents the image of the ATM switch connected to the ADSL Equipment, and

- the resource proxy RP3 that represents the image of the BAS (i.e. the endpoint Z of the end-to-end circuit).

The multilevel workflows involved in the provisioning activity of the service "Offer 1" are shown in figure 3.

Specifically, the level 1 workflow (figure 3a, left) consists of two steps or tasks. The first one (ADSL connectivity, designated 100) is exploded into a level 2 workflow that is executed at the AA level while a mailbox task (generally designated 102 but not detailed in this example) can be performed by an external OSS platform.

The ADSL connectivity task is thus a level 2 workflow W2 as detailed in the right-hand portion of figure 3a that consists of a sequence of level 3 workflows, technology and vendor dependent, that are executed at resource proxy level as detailed in figure 3b.

Specifically, reference 104 denotes a step leading to a choice among vendors A, B, and C providing the ADSL equipment, the ATM switch, and the BAS of figure 2, respectively. Steps 106a, 106b, 106c indicate the creation of respective ports for these vendors, that are subsequently provided respective virtual connections (VCC) in steps 108a, 108b, 108c. Step 110 designates the possible addition of an IP address to the VCC termination to Vendor C branch.

Finally, the level 3 workflows are sequences of the commands that must be performed on the equipment by the resource proxy through the suitable protocol adapters.

Figure 4 shows the activity diagram of the various software components depicted in figure 2 except for the agent AA3 and the resource proxy RP3.

The actions "Find agent" and "Find Proxy" are performed by the manager application MA or the distributed components (application agent AA or resource proxy RP) on the basis of distributed circuit design algorithm not detailed in this invention (any well known path finding algorithms can be used to that purpose). These actions, performed through a strict collaboration among application agents and resource proxies are necessary in order to find the path between the endpoint A and the endpoint Z of the circuit to be provisioned.

This approach is very flexible as regards managing changes in each layer.

In fact, every change in the business view of the service is taken into account by just modifying in the MDB data base the layer 1 processes involved and moving them to the MA.

Every change in the network view of the service (e.g. some Vendor A ADSL equipment is substituted with Vendor D ADSL equipment) is taken into account by just modifying in the MDB data base the layer 2 processes involved (i.e. adding a new branch) and distributed by MA to the AAs.

Every change in the engineering view of the service (e.g. a firmware upgrade on a node) is taken into account by just modifying in the MDB data base the layer 3 processes involved.

In this scenario it is assumed that a protocol adapter suitable for the new equipment is already available.

As a second example the same arrangement described in the foregoing will be considered in the case of a fault scenario: the service "Offer 1" is assumed to be interrupted for some reasons, and a corresponding message is displayed on the MA console.

Figure 6 illustrates an example of multilevel workflows mixed with rules engines that may cope with these circumstances.

The level 1 process is again a workflow and requires that the alert message is displayed on a console of the MA when the ADSL connectivity 100 or the Mailbox sub-service 102 fails with additional information about fault reasons (see figure 6a, left).

The level 2 process (figure 6a, right) is rule-driven: the agent application KB (Knowledge Base) contains all relevant data (e.g. status of network resources, active alarms) collected from various events, from RPs but also from other AAs. The rule "Fault on ADSL path" is an example of alarm correlation (more precisely, fact correlation). For example, when the rule becomes true (step 200) it sends (in a step 202) a new event to the level 1 PE (inside the MA).

The level 3 Process (shown in figure 6b in the case of check port fault, e.g. the equipment of Vendor A) is again rule-driven: a rule is executed (step 204) as soon as RP receives an event from PA, like a SNMP trap. This rule gets more information on port status (step 206) through PA interoperation. After checking in step 208 if port status is operative, it alerts the AA, if necessary, in step 210.

Figure 7 shows the activity diagram for the various platform components.

This case assumes that PA1 (a SNMP protocol adapter) receives a SNMP trap with information "Port X down" on a resource mirrored by RP1, along the ADSL path for "Offer 1" service. The rule engine on RP1
5 activates the rule "Check port fault", then propagates the event to AA1. AA1 accept event and stores it in KB.

Other events, in different order and times, can add facts in KB-AA1 from any RPs under AA1 scope (e.g. rule B and rule C). Facts in KB can raise rules in
10 order to send events to other AA (e.g. from AA2 to KB-AA1), for inter-AA alarms correlation. When condition in AA1 rule "Check ADSL path" becomes true, workflow is executed and a new event is sent to MA1, with information read from facts matched by the rule.

15 Finally, the workflow executed in MA1 causes an alarm like "Offer 1 service fault - link between RP1 and RP2 fault" to appear on a console connected to MA.

A main advantage of the arrangement shown lies the reduction of network traffic due to alarm signaling.
20 Every component (RP, AA and also MA) takes part in alarms processing on different abstraction levels. In that way the alarm correlation function can be implemented (e.g. at the level of the agents AAs) very close to the possible alarm sources. This approach
25 reduces network traffic due to alarms having to be sent to a central system. The flexibility inherent in workflows and rules definition permits the introduction of new equipment with minimal effort (same advantage described in provisioning case).

30 A third example highlights the flexibility of equipment management through level 3 workflow configuration.

This example bears witness to the flexibility in data model handling: after the addition of a new equipment type in a network, by just redefining (e.g. by means of a GUI adapted to manage in a user-friendly manner XML files, for example) the mapping model, the proxy layer automatically creates and maintains a synchronized representation of the new equipment, while operation of all the FCAPS functionalities is the distributed layer is never discontinued.

Specifically, this example is intended to show how the arrangement disclosed can flexibly and easily handle a data model change for an equipment with its vendor and technology dependent features. In summary, the process of replacing a Vendor A equipment with a Vendor B equipment requires only updating the data model (if changed) and modifying of level 3 workflow processes. The RPs are able to recognize the new equipment and utilize the new data model and level 3 workflows to populate the data model.

By way of example an ATM switch and the related scenario are shown in figure 8.

The common data model CMD (compliant with a common model like TMF's SID or DMTF's CIM) is specified using an XML schema file (xsd) stored in the MDB data base together with level 3 processes. The catalog data tables in the network inventory CNI hold the equipment catalog data (characteristic information needed to describe the network resources, often referred also as "metadata" or "templates"). The resource proxy RP represents the ATM Switch equipment of a vendor "A". It holds the image EI of the ATM Switch equipment. Both the catalog data and the equipment image are validated using the common data model specified in the xsd file.

The data model example considers the case depicted in figure 9. An operator O needs to replace an ATM switch of Vendor "A" with an ATM switch of Vendor "B"

This process includes a number of subtask that the operator O must carry out.

A first subtask is to install the hardware equipment: this task deals with the physical installation of the new piece of equipment.

A second subtask is to insert the new equipment in the catalog. Users have to insert the new equipment characteristic into the catalog (e.g. the new vendor name). It is assumed that the common catalog data are stored in a centralized network Inventory (CNI) OSS.

A third subtask is to rewrite the level 3 workflows. This is necessary in order to be able to manage the new equipment (using the new vendor dependent equipment commands) and to deal with the new equipment image (by means of the proper new commands to fill the Resource proxy memory image).

A portion of the level 3 workflows, involved in the resource proxy data model management, is shown in figures 10. The workflow portions shown deal with the management of equipment card data.

The workflows in question contain the following type of commands:

Equipment command: vendor dependent equipment commands performed by the Resource proxy through the suitable protocol adapters (e.g. get card A or get card B - step 300).

CNI command: the commands performed on the CNI (e.g.: inventory.getCatalogInfo(...) - step 302) in order to query catalog information;

Resource proxy Image command: commands performed by the Resource proxy to update (or create) its equipment image (e.g.: `image.setAttribute(...)` - step 310).

5 Following a check (step 304) as to the availability in the proxy image of an object representing a card (if not, the object being created in step 306), the workflow portion allows getting the various card attributes (named Attribute1, Attribute2,
10 Attribute3) values from the equipment (step 308) and then to update (in a step 310) the resource proxy image with the values retrieved.

The vendor dependent equipment differences affect the level 3 workflow. Indeed, the new Vendor B
15 equipment card (Card B) contains only one attribute (named Attribute X). Therefore, the new workflow can be represented again with Figure 10 where step 308 and 310 contain commands to get only attribute X value from equipment and update the RP image consequently.

20 The XML code below shows an XML version, compliant to the common data model, of the resource proxy image subsequent to the execution of the level 3 workflow for the vendor A equipment.

```
25       <Card id="ID2333" name="Card A">
          <AdditionalAttribute name="Vendor" value="A"/>
          <AdditionalAttribute       name="Attribute        1"
value="111"/>
          <AdditionalAttribute       name="Attribute        2"
30 value="222"/>
          <AdditionalAttribute       name="Attribute        3"
value="333"/>

          <PhysicalPort id="ID1" name="Port A">
```

27

```

        <AdditionalAttribute name="Attribute 1"
value="111"/>
        <AdditionalAttribute name="Attribute 2"
value="222"/>
5      <AdditionalAttribute name="Attribute 3"
value="333"/>
      </PhysicalPort>
      <PhysicalPort id="ID2" name="Port B">
        <AdditionalAttribute name="Attribute 1"
10 value="aaa"/>
        <AdditionalAttribute name="Attribute 2"
value="bbb"/>
        <AdditionalAttribute name="Attribute 3"
value="ccc"/>
15      </PhysicalPort>
      </Card>
```

The further XML code below shows an XML version, compliant to the common data model, of the resource proxy image subsequent to the execution of the level 3

20 Workflow for the vendor B equipment.

```

    <Card id="ID4503" name="Card B">
      <AdditionalAttribute name="Vendor" value="B"/>
      <AdditionalAttribute name="Attribute X"
5 value="XXX"/>
      <PhysicalPort id="ID1" name="Port A">
        <AdditionalAttribute name="Attribute X"
value="111"/>
      </PhysicalPort>
      <PhysicalPort id="ID2" name="Port B">
10 <AdditionalAttribute name="Attribute X"
value="aaa"/>
      </PhysicalPort>
      <PhysicalPort id="ID3" name="Port C">
        <AdditionalAttribute name="Attribute X"
15 value="yyy"/>
      </PhysicalPort>
    </Card>

```

Figure 11 shows the activity diagram of the
20 various platform components involved in the resource
proxy data model management. The GUI is intended to be
the graphical user interface used by a human operator
to work on the MDB and to control the MA. "Eqpt" stands
for the equipment "ATM switch".

25 New equipment with their vendor dependent features
is thus managed in a flexible and simple way. For
example, the process of replacing a Vendor A equipment
with a vendor B equipment involves only the
configuration of the network inventory catalog data and
30 of the new level 3 workflow. The agents are able to
recognize the new equipment in the catalog and the
associated new level 3 workflow and to use these to
manage the new equipment and its resource proxy image.

The arrangement described can be extended for a number of layers greater than three, where the agent layer can be structured in a hierarchy. Preferably, the proxy layer is not split in order to avoid introducing
5 bottlenecks in the network interactions; also, evolution of equipment may result in the proxy layer being arranged in the equipments, when they will offer standard interfaces with a unified data model. If all functionalities can be implemented as distributed, a
10 separate manager/coordinator layer can be dispensed with by promoting some agents to external communication tasks.

It is thus evident that, the basic principles of the invention remaining the same, the details and
15 embodiments may widely vary with respect to what has been described and illustrated purely by way of example, without departing from the scope of the presented invention as defined in the annexed claims.

CLAIMS

1. A system architecture for managing a telecommunication network (N) including network
5 equipments, said equipments having associated control interfaces (if_{N α} , if_{N w} , if_{N y} , if_{N t}), the architecture comprising:

- a base layer (RA, RP) proxying said interfaces (if_{N α} , if_{N w} , if_{N y} , if_{N t}) and decoupling said
10 interfaces (if_{N α} , if_{N w} , if_{N y} , if_{N t}) from management functions, and

- a support layer (AA) comprised of a community of agents co-ordinating operation of said base layer (RA, RP) in order to support distributed management
15 functionalities, said base layer and said support layer constituting separated superposed layers in said architecture.

2. The architecture of claim 1, characterized in that said distributed functionalities include FCAPS
20 (Fault, Configuration, Accounting, Performance, Security) functionalities.

3. The architecture of claim 1, characterized in that said base layer includes:

- a sub-layer of protocol adapters (PA) for
25 interfacing a set of network equipments offering a given protocol, and

- a sub-layer of resource proxy modules (RP), each said proxy module (RP) providing a representation of the configuration of a given network equipment
30 according to a defined information model.

4. The architecture of claim 3, characterized in that said resource proxy modules (RP) are configured for aligning said representation to the network of a given network equipment by at least one operation
35 selected out of the group consisting of:

- performing all the management actions on said network (N) by invoking operation through at least one associated protocol adapter (PA);

- receiving at said resource proxy modules (RP) all the notifications sent by said network equipments; and

- performing a periodical verification of alignment between the representation of the network equipments and said network equipments.

10 5. The architecture of claim 4, characterized in that said resource proxy modules (RP) are configured for enrichment with element manager information.

6. The architecture of claim 4, characterized in that said resource proxy modules (RP) are configured 15 for running processes using a process executor (PE).

7. The architecture of claim 4, characterized in that said resource proxy modules (RP) are configured for interacting directly with one another in an inter-working relationship.

20 8. The architecture of claim 1, characterized in that said agents (AA) in said community are configured for running vendor and technology independent services.

9. The architecture of claim 1, characterized in that it includes at least one manager application (MA) 25 configured for performing functions selected from the group consisting of:

- managing distribution of processes between said base layer and said support layer,

- managing distribution of information models 30 between said base layer and said support layer,

- monitoring the state of the architecture on the basis of information provided by said agents (AA) in said community,

- interacting with external systems, and

35 - executing management processes.

10. The architecture of claim 9, characterized in that said at least one manager application (MA) comprises a separated, additional upper layer in said architecture.

5 11. The architecture of claim 9, characterized in that said at least one manager application (MA) is at least partly integrated to said support layer (AA).

12. The architecture of claim 1, characterized in that all said layers in said architecture include
10 process executors (PE).

13. The architecture of claim 12, characterized in that said process executors (PE) comprise at least one of a workflow, a rule engine and combinations thereof.

14. The architecture of claim 1, characterized in
15 that said architecture includes agents (AA) hosted on different machines, said agents being movable among different machines.

15. The architecture of claim 1, characterized in that said layers (PA, RP; AA; MA) in said architecture
20 include components adapted to perform respective functions based on respective instruction information provided to them and in that a data base (MDB) is provided storing said instruction information, the architecture being arranged for distributing said
25 instruction information from said data base (MDB) to said components.

16. The architecture of claim 15, characterized in that said instruction information comprises at least one of:

30 - process definitions such as workflows and rules,
and

- data model definitions.

17. The architecture of claim 15, characterized in that it includes at least one manager application (MA)
35 configured for managing distribution of information

models between said base layer and said support layer, and in that said data base (MDB) is associated with said at least one manager application.

18. A method of managing a telecommunication network (N) including network equipments, said equipments having associated control interfaces (if_{N α} , if_{N w} , if_{N y} , if_{N t}), the method comprising the steps of:

- providing a base layer (RA, RP) proxying said interfaces (if_{N α} , if_{N w} , if_{N y} , if_{N t}) and decoupling said interfaces (if_{N α} , if_{N w} , if_{N y} , if_{N t}) from management functions, and

- supporting distributed management functionalities via a support layer (AA) comprised of a community of agents co-ordinating operation of said base layer (RA, RP), said base layer and said support layer constituting separated superposed layers in said architecture.

19. The method of claim 18, characterized in that it includes the steps of including FCAPS (Fault, Configuration, Accounting, Performance, Security) functionalities as said distributed management functionalities.

20. The method of claim 18, characterized in that it includes the steps of providing:

- a sub-layer of protocol adapters (PA) for interfacing a set of network equipments offering a given protocol, and

- a sub-layer of resource proxy modules (RP), each said proxy module (RP) providing a representation of the configuration of a given network equipment according to a defined information model.

21. The method of claim 20, characterized in that it includes the step of configuring said resource proxy modules (RP) for aligning said representation to the

network of a given network equipment by at least one operation selected out of the group consisting of:

- performing all the management actions on said network (N) by invoking operation through at least one
5 associated protocol adapter (PA);

- receiving at said resource proxy modules (RP) all the notifications sent by said network equipments;
and

- performing a periodical verification of
10 alignment between the representation of the network equipments and said network equipments.

22. The method of claim 21, characterized in that it includes the step of configuring said resource proxy modules (RP) for enrichment with element manager
15 information.

23. The method of claim 20, characterized in that it includes the step of configuring said resource proxy modules (RP) for running processes using a process
executor (PE).

20 24. The method of claim 20, characterized in that it includes the step of configuring said resource proxy modules (RP) for interacting directly with one another in an inter-working relationship.

25 25. The method of claim 18, characterized in that it includes the step of configuring said agents (AA) in said community for running vendor and the technology independent services.

26. The method of claim 18, characterized in that it includes the steps of providing at least one
30 manager application (MA) for performing steps selected from the group consisting of:

- managing distribution of processes between said base layer and said support layer,

- managing distribution of information models
35 between said base layer and said support layer,

- monitoring the state of said layers on the basis of information provided by said agents (AA) in said community,

- interacting with external systems, and
- 5 - executing management processes.

27. The method of claim 26, characterized in that it includes the step of configuring said at least one manager application (MA) as a separated upper layer in addition to said base proxying layer and said support
10 layer.

28. The method of claim 26, characterized in that it includes the step of at least partly integrating to said support layer (AA) said at least one manager application (MA).

15 29. The method of claim 18, characterized in that it includes the step of providing process executors (PE) in all said layers.

30. The method of claim 29, characterized in that it includes the step of providing in said process
20 executors (PE) at least one of a workflow, a rule engine and combinations thereof.

31. The method of claim 18, characterized in that it includes the steps of:

- hosting at least part of said agents (AA) on
25 different machines, and
- moving said agents among different machines.

32. The method of claim 18, characterized in that it includes the steps of:

- including in said layers (PA, RP; AA; MA)
30 components adapted to perform respective functions based on respective instruction information provided to them;
- providing a data base (MDB) is provided storing said instruction information, and

- distributing said instruction information from said data base (MDB) to said components.

33. The method of claim 32, characterized in that it includes the step of providing in said instruction
5 information at least one of:

- process definitions such as workflows and rules,
and

- data model definitions.

34. The method of claim 32, characterized in that
10 it includes the steps of:

- providing at least one manager application (MA) configured for managing distribution of information models between said base layer and said support layer,
and

15 - associating said data base (MDB) with said at least one manager application.

35. Communication network associated to control interfaces ($if_{N_{\alpha}}$, if_{N_w} , if_{N_y} , if_{N_t}) and to a management system architecture according to any of
20 claims 1-17.

36. A computer program product loadable in the memory of at least one computer and including software code portions for performing the steps of the method of any of claims 18 to 34.

FIG - 1

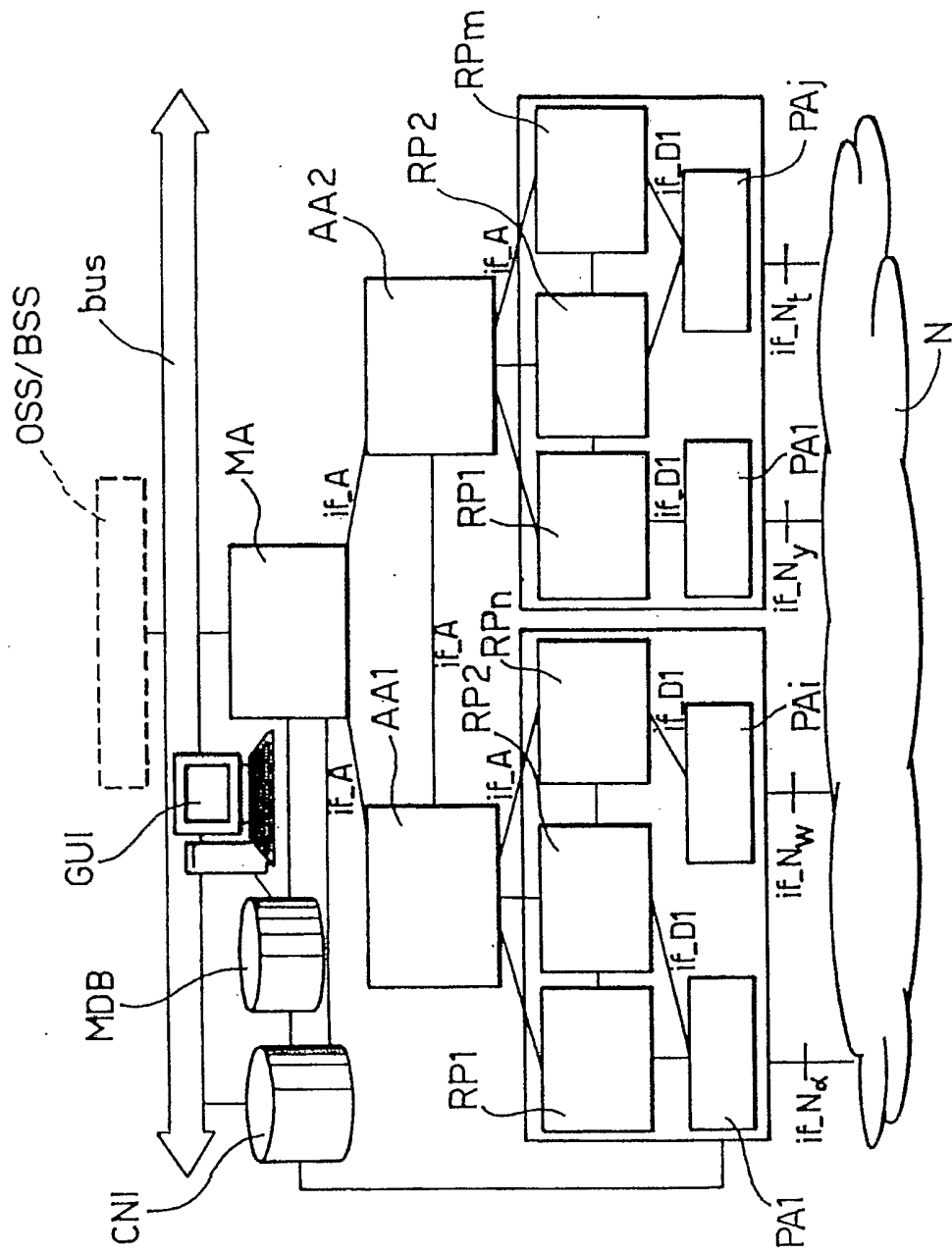

Fig. 2

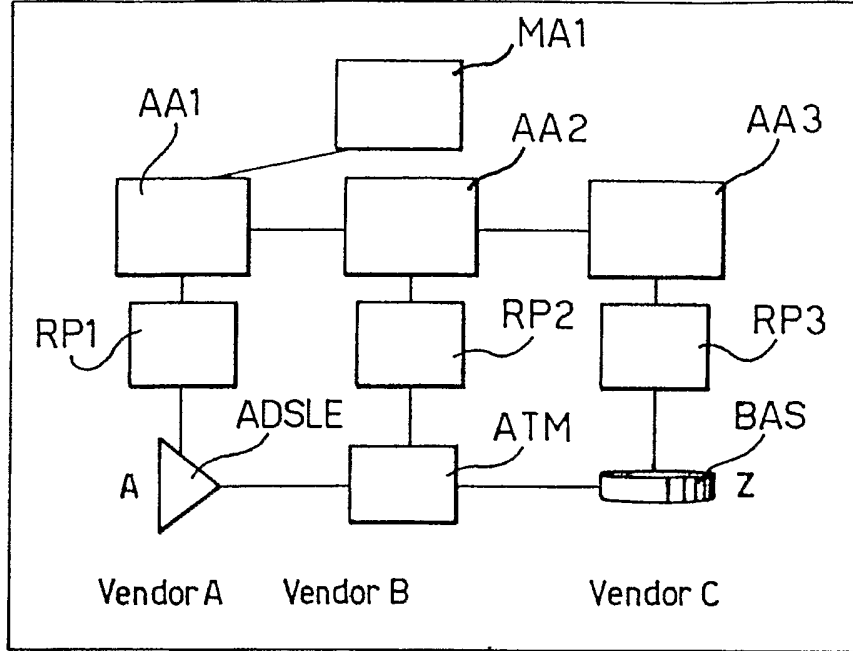

Fig. 4

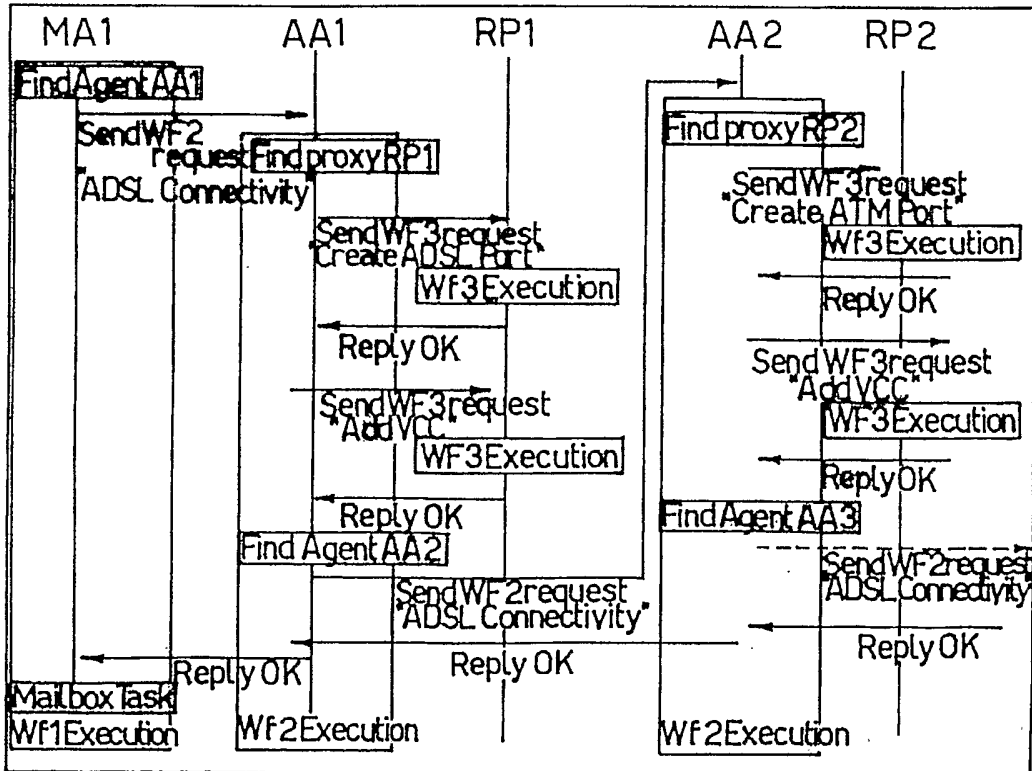

Fig. 3a

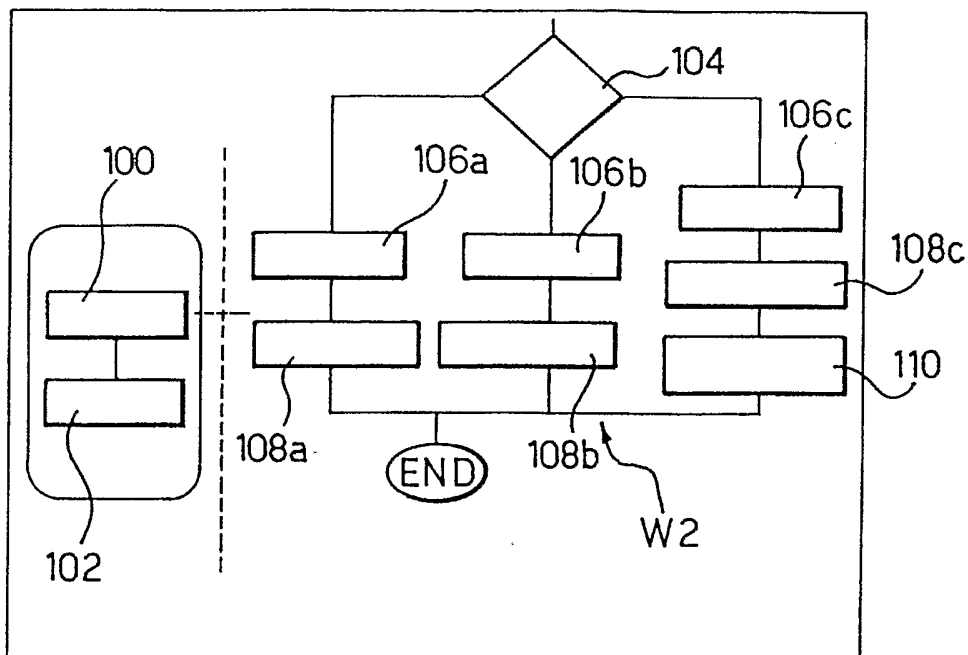

Fig. 3b

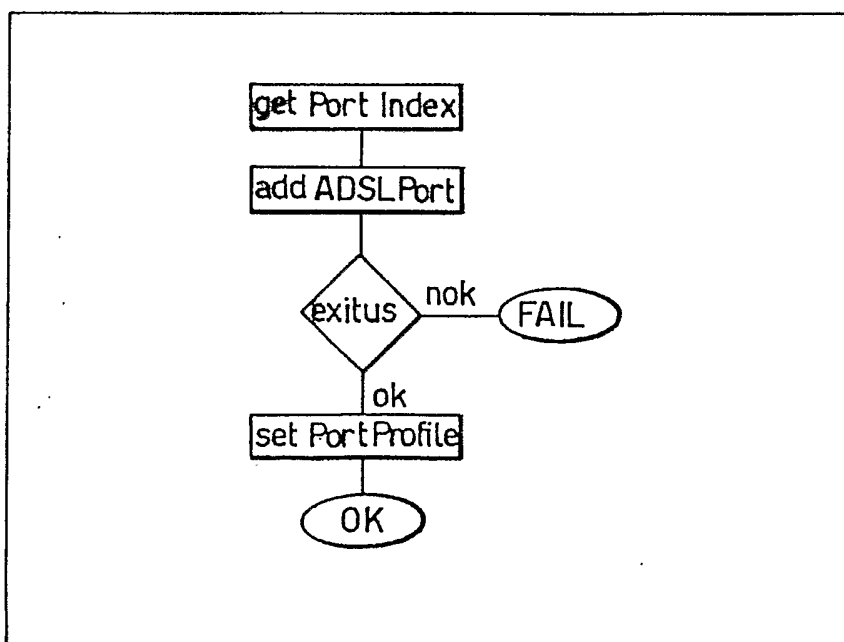

Fig. 6a

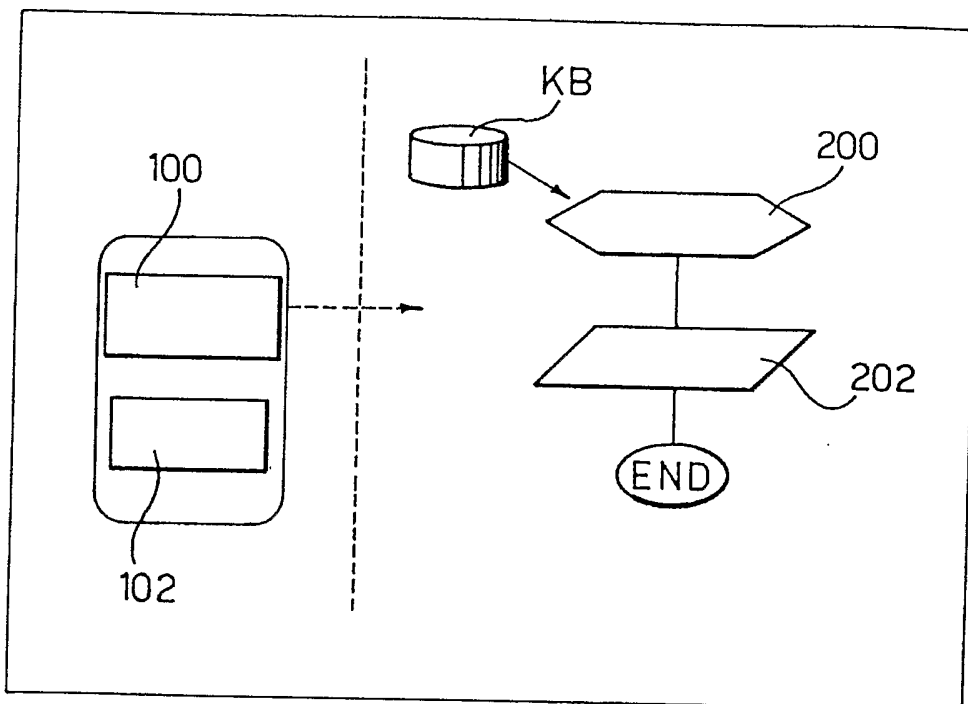

Fig. 6b

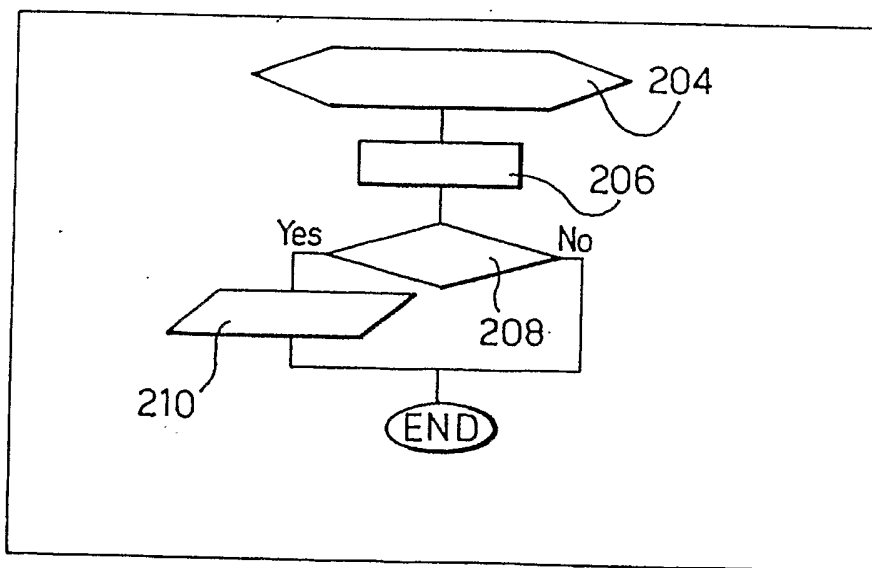

Fig. 7

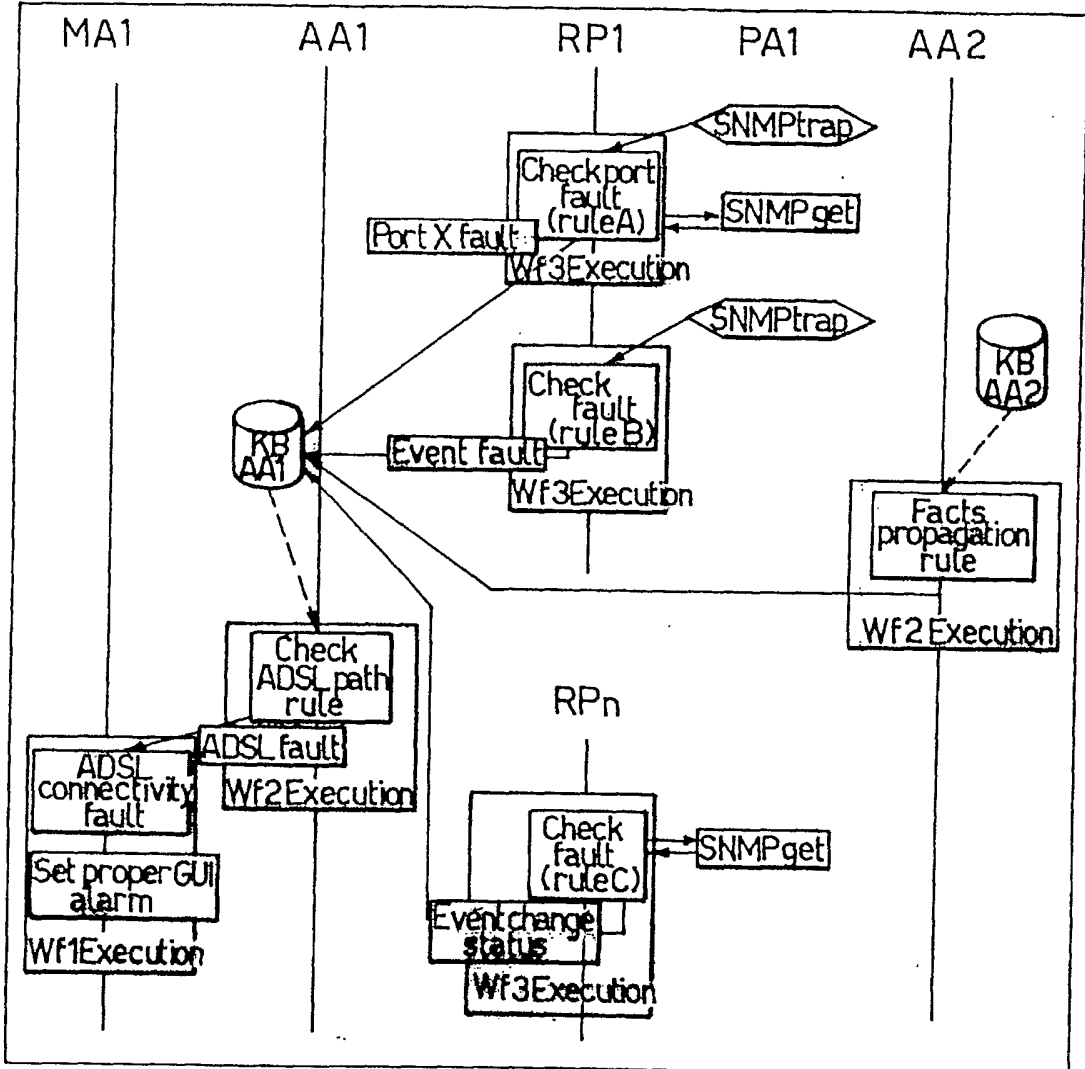

Fig. 9

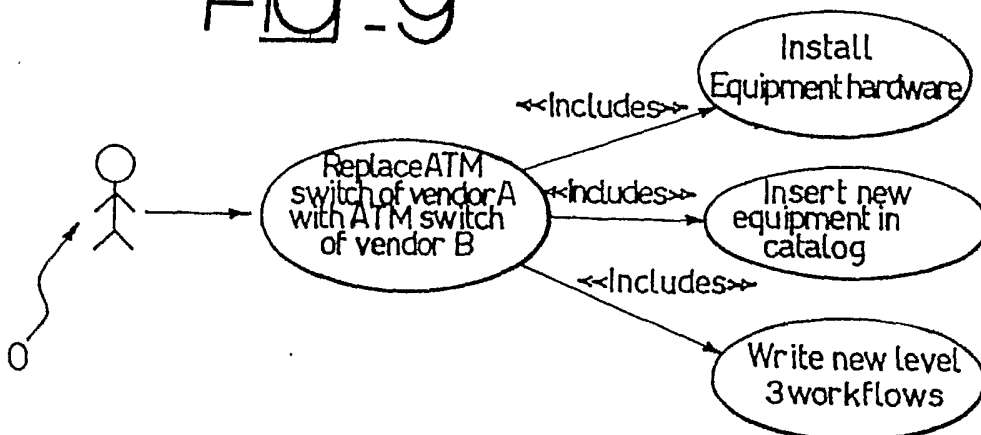

Fig. 5

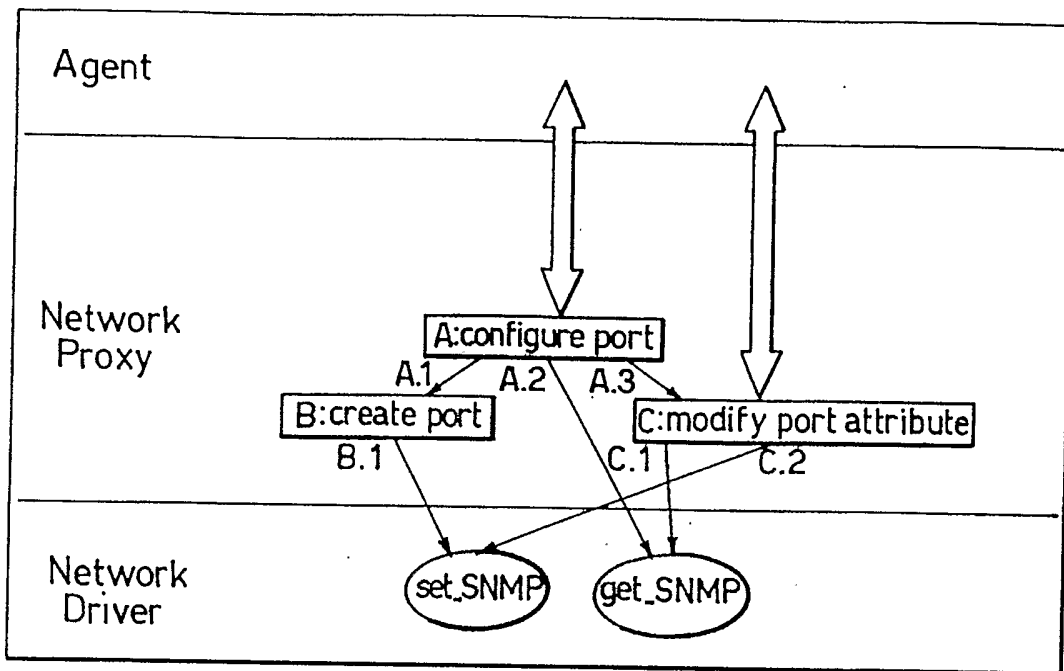

Fig. 8

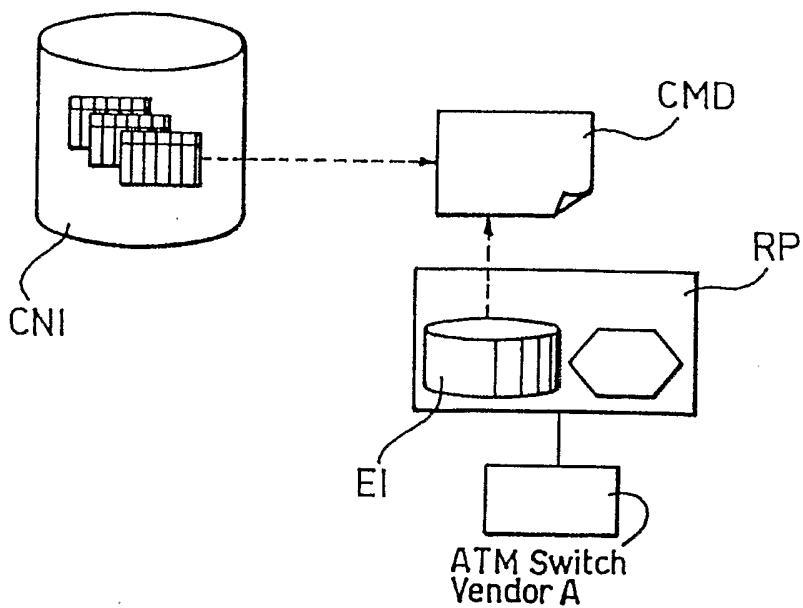
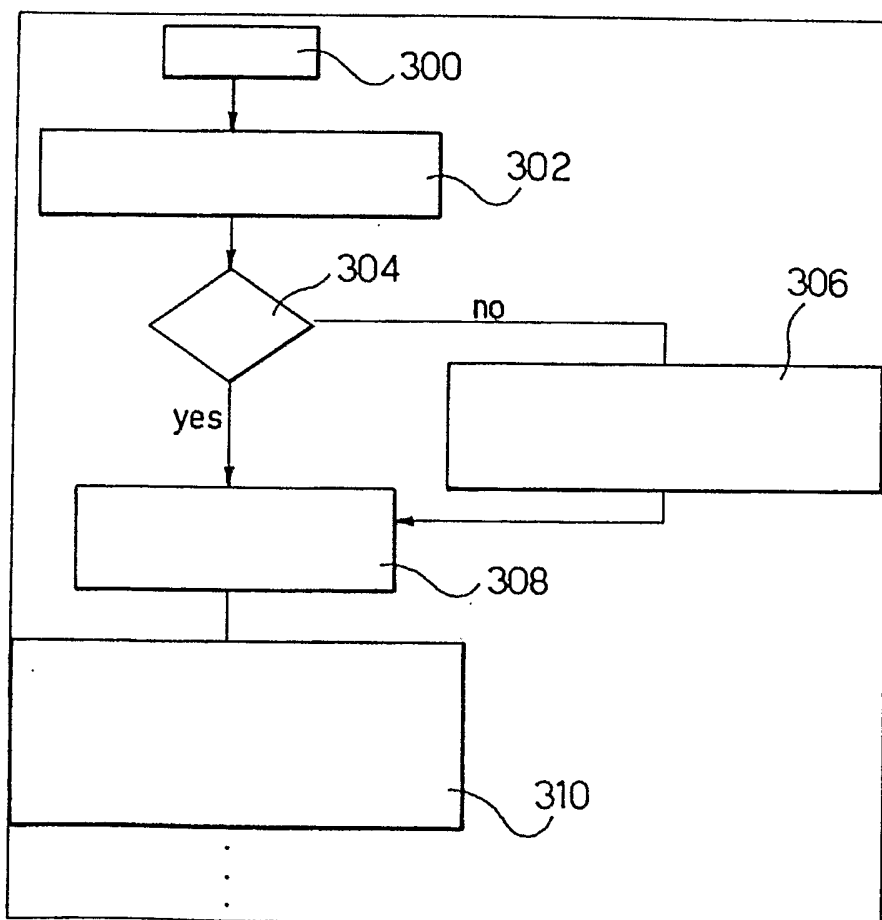

Fig. 10



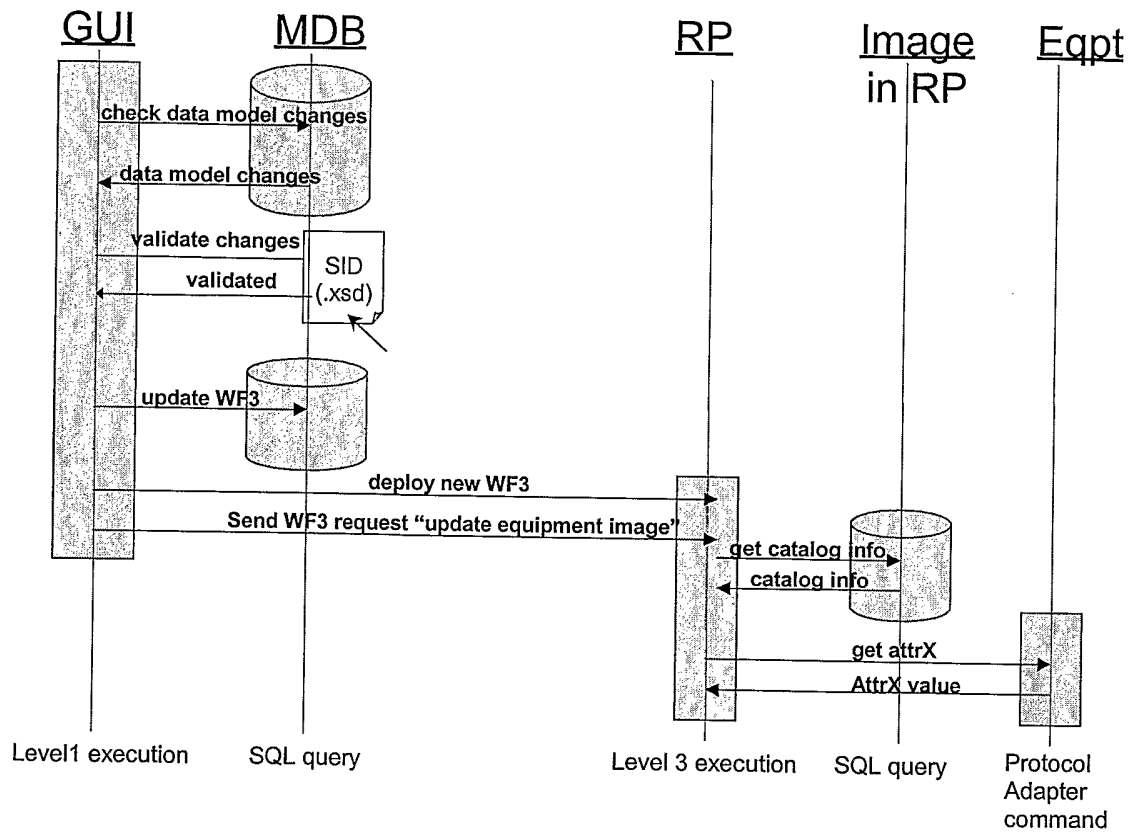

Fig. 11

INTERNATIONAL SEARCH REPORT

International Application No
PCT/IT 03/00511

A. CLASSIFICATION OF SUBJECT MATTER IPC 7 H04Q3/00 H04L12/24		
According to International Patent Classification (IPC) or to both national classification and IPC		
B. FIELDS SEARCHED		
Minimum documentation searched (classification system followed by classification symbols) IPC 7 H04Q H04L		
Documentation searched other than minimum documentation to the extent that such documents are included in the fields searched		
Electronic data base consulted during the international search (name of data base and, where practical, search terms used) EPO-Internal, WPI Data, PAJ, IBM-TDB, INSPEC		
C. DOCUMENTS CONSIDERED TO BE RELEVANT		
Category *	Citation of document, with indication, where appropriate, of the relevant passages	Relevant to claim No.
X	US 2002/032769 A1 (BARKAI S ET AL) 14 March 2002 (2002-03-14) cited in the application paragraph '0047! - paragraph '0051! paragraph '0057! - paragraph '0068! paragraph '0085! -----	1-36
X	HANAKI M ET AL: "COOPERATIVE ATM-LAN/WAN END-TO-END MANAGEMENT USING CNM INTERFACE" IEEE GLOBAL TELECOMMUNICATIONS CONFERENCE. PHOENIX, ARIZONA, NOV. 3 - 8, 1997, GLOBAL TELECOMMUNICATIONS CONFERENCE (GLOBECOM), NEW YORK, IEEE, US, vol. VOL. 3, 3 November 1997 (1997-11-03), pages 1455-1460, XP000737767 ISBN: 0-7803-4199-6 page 1456; figure 2 ----- -/--	1-36
<input checked="" type="checkbox"/> Further documents are listed in the continuation of box C. <input checked="" type="checkbox"/> Patent family members are listed in annex.		
* Special categories of cited documents :		
A document defining the general state of the art which is not considered to be of particular relevance *E* earlier document but published on or after the international filing date *L* document which may throw doubts on priority claim(s) or which is cited to establish the publication date of another citation or other special reason (as specified) *O* document referring to an oral disclosure, use, exhibition or other means *P* document published prior to the international filing date but later than the priority date claimed	*T* later document published after the international filing date or priority date and not in conflict with the application but cited to understand the principle or theory underlying the invention *X* document of particular relevance; the claimed invention cannot be considered novel or cannot be considered to involve an inventive step when the document is taken alone *Y* document of particular relevance; the claimed invention cannot be considered to involve an inventive step when the document is combined with one or more other such documents, such combination being obvious to a person skilled in the art. *&* document member of the same patent family	
Date of the actual completion of the international search	Date of mailing of the international search report	
24 May 2004	01/06/2004	
Name and mailing address of the ISA	Authorized officer	
European Patent Office, P.B. 5818 Patentlaan 2 NL - 2280 HV Rijswijk Tel. (+31-70) 340-2040, Tx. 31 651 epo nl, Fax: (+31-70) 340-3016	Vercauteren, S	

INTERNATIONAL SEARCH REPORT

International Application No
PCT/IT 03/00511

C.(Continuation) DOCUMENTS CONSIDERED TO BE RELEVANT		
Category °	Citation of document, with indication, where appropriate, of the relevant passages	Relevant to claim No.
X	EP 1 241 828 A (CIT ALCATEL) 18 September 2002 (2002-09-18) paragraph '0015! - paragraph '0018! paragraph '0034! - paragraph '0052! -----	1-36

INTERNATIONAL SEARCH REPORT

International Application No
PCT/IT 03/00511

Patent document cited in search report	Publication date	Patent family member(s)	Publication date
US 2002032769	A1	14-03-2002	
		AU 2758901 A	12-11-2001
		AU 5737401 A	12-11-2001
		CA 2330413 A1	28-10-2001
		CA 2368627 A1	08-11-2001
		EP 1150454 A2	31-10-2001
		EP 1301864 A1	16-04-2003
		WO 0184331 A1	08-11-2001
		WO 0184329 A1	08-11-2001
		AU 4931401 A	20-11-2001
		AU 5575101 A	12-11-2001
		CA 2343370 A1	28-10-2001
		CA 2368619 A1	08-11-2001
		EP 1150455 A2	31-10-2001
		EP 1190535 A1	27-03-2002
		WO 0186457 A1	15-11-2001
		WO 0184787 A1	08-11-2001
		US 2001039577 A1	08-11-2001
		US 2002009085 A1	24-01-2002
		AU 8313001 A	18-02-2002
		CA 2374064 A1	14-02-2002
		EP 1305723 A1	02-05-2003
		WO 0213034 A1	14-02-2002
		US 2002027925 A1	07-03-2002
EP 1241828	A	18-09-2002	EP 1241828 A1 18-09-2002