

(19) World Intellectual Property Organization
International Bureau



(43) International Publication Date
19 February 2009 (19.02.2009)

PCT

(10) International Publication Number
WO 2009/022105 A1

(51) International Patent Classification:
A45F 5/00 (2006.01) A45F 3/02 (2006.01)

(74) Agent: HAMILTON, Alistair; Ty Eurgain, Cefn Eurgain Lane, Rhosesmor, Nr. Mold, Flintshire CH7 6PG (GB).

(21) International Application Number:
PCT/GB2008/002691

(81) Designated States (unless otherwise indicated, for every kind of national protection available): AE, AG, AL, AM, AO, AT, AU, AZ, BA, BB, BG, BH, BR, BW, BY, BZ, CA, CH, CN, CO, CR, CU, CZ, DE, DK, DM, DO, DZ, EC, EE, EG, ES, FI, GB, GD, GE, GH, GM, GT, HN, HR, HU, ID, IL, IN, IS, JP, KE, KG, KM, KN, KP, KR, KZ, LA, LC, LK, LR, LS, LT, LU, LY, MA, MD, ME, MG, MK, MN, MW, MX, MY, MZ, NA, NG, NI, NO, NZ, OM, PG, PH, PL, PT, RO, RS, RU, SC, SD, SE, SG, SK, SL, SM, ST, SV, SY, TJ, TM, TN, TR, TT, TZ, UA, UG, US, UZ, VC, VN, ZA, ZM, ZW.

(22) International Filing Date: 7 August 2008 (07.08.2008)

(25) Filing Language: English

(26) Publication Language: English

(30) Priority Data:
0715629.2 10 August 2007 (10.08.2007) GB

(84) Designated States (unless otherwise indicated, for every kind of regional protection available): ARIPO (BW, GH, GM, KE, LS, MW, MZ, NA, SD, SL, SZ, TZ, UG, ZM, ZW), Eurasian (AM, AZ, BY, KG, KZ, MD, RU, TJ, TM), European (AT, BE, BG, CH, CY, CZ, DE, DK, EE, ES, FI, FR, GB, GR, HR, HU, IE, IS, IT, LT, LU, LV, MC, MT, NL, NO, PL, PT, RO, SE, SI, SK, TR), OAPI (BF, BJ, CF, CG, CI, CM, GA, GN, GQ, GW, ML, MR, NE, SN, TD, TG).

(71) Applicant (for all designated States except US): YOKE ENTERPRISES LTD [GB/GB]; Trem-y-Ddol, Rhuallt, St. Asaph LL17 0TP (GB).

(72) Inventor; and

(75) Inventor/Applicant (for US only): DAVIES, Matthew, William [GB/GB]; Trem-y-Ddol, Rhuallt, St. Asaph LL17 0TP (GB).

Published:
— with international search report

(54) Title: APPARATUS TO ASSIST A PERSON CARRYING ONE OR MORE BAGS

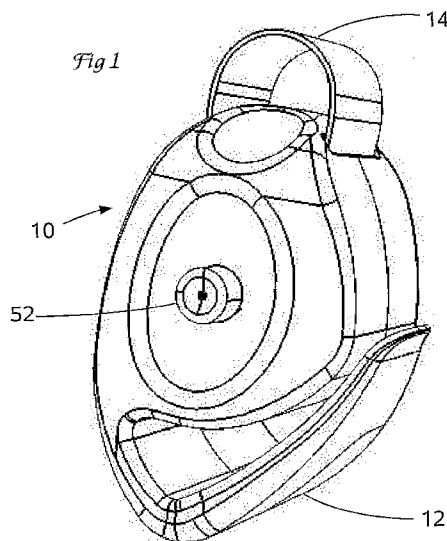

(57) Abstract: Apparatus to assist a person carrying one or more bags is disclosed. The apparatus comprises a body (10) having a hook (12) by which it can be connected to a bag to be carried. A deployable strap (14) extends from a spool within the body to form a loop externally of the body (10), whereby the loop can be carried on a person's shoulder. Locking means within the body that has a control (52) which can be operated by a user to selectively allow or prevent rotational movement of the spool and thereby allow or prevent retraction of the strap from the body (10). The locking means includes a locking plunger that is coaxial with the spool, and which can move axially within the body between an unlocked position, in which the spool can rotate about the locking plunger, and locked position in which rotational movement of the spool with respect to the locking plunger is restricted. There is only limited or no rotational movement between the body and the locking plunger, when the locking plunger is in the locked position.



WO 2009/022105 A1

Apparatus to assist a person carrying one or more bags

5 This invention relates to apparatus to assist a person carrying one or more bags.

Many people experience difficulty carrying bags, such as low-density polyethylene shopping bags. This difficulty can be particularly severe where the load within the bag or bags is heavy, a person has multiple bags to carry, or the person has hands that have been weakened by age or infirmity. Even people who are entirely able-bodied can find that carrying a heavy shopping
10 bag for all but the briefest of times can be tiring and can sometimes make their hands quite painful.

It has been observed that the difficulties encountered when carrying loaded bags arise from several physical features of a typical bag, particularly a low-cost shopping bag. The handles provided are so small that the entire load of the bag must be carried by a person's fingers.
15 Where multiple bags are to be carried, these must be carried in the fingers of two hands, and must, from time to time, be carried by the fingers of one hand, when a free hand is needed to perform other tasks. The handles also transfer the load into a person's fingers over a very small surface area, with the result that they cut in to the flesh on the fingers to cause discomfort or pain.

20 Compared with the load that a person can carry in their fingers, most people can comfortably carry a much heavier load that is properly distributed.

WO-A-2005/023684 shows a device for carrying one or more bags that has a body that has retractable hooks on which bags can be hung and a retractable strap that can be placed over a person's shoulder. However, the mechanism disclosed for controlling withdrawal and

retraction of the strap is not highly developed, and will be difficult to implement effectively in practice.

An aim of this invention is to provide apparatus that allows a person to carry a load in one or more bags to a greater total capacity or more comfortably than has been previously possible,
5 which is reliable and robust in use.

To this end, from a first aspect, the invention provides apparatus to assist a person carrying one or more bags comprising: a body having attachment means by which it can be connected to a bag to be carried; a deployable strap that extends from a spool within the body to form a loop externally of the body, whereby the loop can be carried on a person's shoulder; a locking means
10 within the body which can be operated by a user to selectively allow or prevent rotational movement of the spool and thereby allow or prevent retraction of the strap from the body; wherein, in preferred embodiments, the locking means includes a locking plunger that is coaxial with the spool, and which can move axially within the body between a free position in which the spool can rotate about the locking plunger and locked position in which rotational
15 movement of the spool with respect to the locking plunger is restricted, there being only limited or no rotational movement between the body and the locking plunger when the locking plunger is in the locked position.

It has been found that this arrangement can provide a robust and reliable mechanism by which deployment of the strap can be controlled by a user.

20 Apparatus embodying the invention typically includes biasing means that urges the locking plunger towards the locked position. This ensures that the strap cannot run free unless a user specifically decides that it should so do. Conveniently, the biasing means includes a spring such as a coil spring. It may act in compression between the locking plunger and the body. In such embodiments, the coil spring typically surrounds a portion of the locking plunger.

25 When in the locked position, a portion of the locking plunger typically projects from the body. This allows a user to apply manual pressure to the projecting portion to urge the locking plunger to the unlocked position. Effectively, it serves as an operating button.

Ribs and keyways of the locking plunger and the body are in interengagement to permit axial but substantially prevent rotational movement between the locking plunger and the body. For example, the locking plunger may carry ribs that engage with keyways of the housing. Alternatively, other interengaging formations may be provided.

5 The spool and the locking plunger may carry teeth which interengage when the locking plunger is in the locked position and which can move past one another during mutual rotation of the spool and the locking plunger when the locking plunger is in the unlocked position. In such embodiments, the spool and the locking plunger can typically rotate with respect to one another when the locking plunger is in the locked position by substantially less than one
10 complete turn.

Ideally, mutual rotation of the spool and the locking plunger is entirely eliminated when the locking plunger is in the locked position. However, since these components must slide with respect to one another, in practice a small amount of rotational movement will still be present. For example, the spool and the locking plunger can rotate with respect to one another when
15 the locking plunger is in the locked position by no more than 2 degrees.

Most advantageously, embodiments of the invention include retraction means for automatically winding the strap onto the spool. While the retraction means could be manually-operable, it is preferred that the retraction means operate automatically. In preferred embodiments, the retraction means includes a helical spring. Therefore, energy is stored in the spring as the strap
20 is withdrawn from the body, and that energy serves to retract the strap into the housing.

For economy of manufacture, the body, the locking plunger and the spool may be formed as one or more mouldings of plastic material such as ABS.

An embodiment of the invention will now be described in detail, by way of example, and with reference to the accompanying drawings, in which:

25 Figures 1 and 2 are front and rear perspective side views of an embodiment of the invention;

Figure 3 is an exploded view of the operative components of the embodiment of Figures 1 and 2;

Figure 4 and 5 are perspective views of shell components of the embodiment of Figures 1 and 2;

5 Figure 6 and 7 are perspective views of a spool component of the embodiment of Figures 1 and 2;

Figures 8 and 9 are front and rear perspective views of a locking plunger component of the embodiment of Figures 1 and 2; and

Figures 10, 11 and 12 show a user deploying the device of Figures 1 and 2.

10 With reference first to Figures 1 and 2, an embodiment of the invention comprises a body 10 that has an integrally formed hook portion 12. The body 10 contains an elongate strap 14, a loop of which can be withdrawn from the body 10 in a controlled manner.

In this embodiment, the body 10 comprises first and second shell components 20, 22 each being formed as a respective plastic moulding and shown in detail in Figures 4 and 5. The shell
15 components 20, 22 are secured together at a central parting line. When connected in this manner, the shell components 20, 22 have a generally smooth outer surface, while internally, the shell components 20, 22 have formations for carrying a mechanism associated with deployment of the strap, as will be described below.

The operative components of the embodiment will now be described.

20 The embodiment includes a spool 26 upon which the strap 14 can be wound. The spool 26 has a winding portion that 30 that is generally cylindrical about a long axis. The axial length of the winding portion 30 is slightly greater than the width of the strap 14. A fixing formation 32 extends the axial length of the winding portion 30 to which portions at both ends of the strap 14 can be secured.

The spool 26 has a radially projecting flange 34. The flange 34 presents a radial, annular surface 36 towards the winding portion 30. Surrounding the periphery of the flange 34 is an axially projecting lip 38 that extends away from the winding portion 30.

5 A bore 40 extends axially through the spool 26. The bore 40 is bounded by a generally cylindrical, inward-facing wall, there being first and second sets of teeth projecting 42, 44 inwardly from the wall into the bore. Radially inward surfaces of the teeth 42, 44 are arcuate in shape, centred upon the axis of the bore 40. The disposition and function of the teeth will be described in due course. Several fins 46 project from the flange radially into the bore.

10 The embodiment further comprises a locking plunger 50. The locking plunger 50 is formed as a plastic moulding that is elongate and rotationally symmetrical about an axis and is principally cylindrical. The locking plunger 50 is divided into two axial regions: a button region 52 and an inner region 54, the latter being of larger diameter than the former.

15 A first set of four teeth 56 is disposed close to an axial end of the inner region 54 of the locking plunger 50 remote from the button region 52. Each tooth 54 has an arcuate circumferential wall of radius greater than that of the inner region 54 of the locking plunger 50 and two radial walls. The teeth 56 are equally spaced apart around the circumference of the inner region 54 of the locking plunger 50.

20 A second set of four teeth 60 is disposed close to the opposite axial end of the inner region 54 of the locking plunger 50 adjacent to the button region 52. Each tooth 60 has an arcuate circumferential wall of radius greater than that of the inner region 54 of the locking plunger 50 and two radial walls. The teeth 60 are equally spaced apart around the circumference of the inner region 54 of the locking plunger 50, but are offset about the axis from the teeth 54 of the first set. The offset is equal to the circumferential extent of the teeth, such that each tooth 54 of the first set has one of its radial walls circumferentially aligned with one of the radial walls
25 of a corresponding tooth 60 of the second set. A radially-projecting tooth 62 extends for approximately half the axial length of the button region from the circumferential centre of each of the teeth 60.

The locking plunger 50 is hollow. Internally of the inner region 54 a plurality of ribs 64 (in this case, there are eight) project part-way radially towards the axis. The teeth extend from the

button region 52 approximately half the axial length of the inner region 54 and are circumferentially equally-spaced.

In the assembled device, the locking plunger 50 is carried on a spigot 70 that projects inwardly of the second shell component 22. The spigot 70 is formed as a hollow cylinder and is dimensioned to pass into the inner region 54 of the locking plunger 50 such that the locking plunger 50 can rotate upon it. The presence of the ribs 63 limits the axial extent to which the spigot 70 can enter the inner region 54 of the locking plunger 50. A helical compression spring 72 is located within the spigot 70 to bias the locking plunger 50 in a direction towards the first shell component 20. Also carried on the spigot 70 is a torsion spring 74 formed from about eight turns of spring steel strip. An inner end of the torsion spring 74 is retained in a slot 76 in the spigot 70. A washer 90 is disposed between the torsion spring 74 and the second shell component 22 to allow free rotation of the coils of the spring 74.

The spool 26 is carried on the locking plunger 50, such that the inner region 54 of the locking plunger 50 extends within the bore 40 of the spool 26. Radial alignment of the locking plunger 50 is maintained coaxial with the spool 26 is ensured by the locking plunger 50 bearing against radially inward surfaces of the teeth 42, 44. An outer end region of the torsion spring 74 is secured within slots 78 formed in the lip 38 of the flange 34.

The button region 52 of the locking plunger 50 extends through a bore 80 in the first shell component 20. In the assembled condition, the aperture is coaxial with the spigot 70. Four axial keyways 82 are formed in an inner surface of the bore 80. Each radially-projecting tooth 62 of the locking plunger 50 enters into a respective keyway 82, thereby preventing rotation of the locking plunger 50.

Operation of the device will now be described.

Assume that the device is in a starting condition in which the strap 14 is wound fully onto the winding portion 30 of the spool 26 and the torsion spring 74 is almost unwound. A small amount of the strap 14 projects from the body 10 through a slot 84 and is secured to form a loop, as shown in Figures 1 and 2. In this condition, the teeth 56, 60 of the locking plunger 50 are aligned axially with the teeth 42, 44 of the spool 26 thereby preventing rotation of the spool 26 with respect to the locking plunger 50 (or at least limiting such movement to be

operationally insignificant for instance to less than a few degrees), and therefore, with respect to the body 10. An end portion of the button region 52 of the locking plunger 50 projects from the body 10.

A user can then displace the locking plunger 50 axially against the force of the compression
5 spring 72 by displacing the end portion of the button region 52 into the body 10 until the locking plunger comes into contact with the fins 46, which prevent its further movement. The teeth 56, 60 of the locking plunger 50 are no longer aligned with the teeth 42, 44 of the spool 26, so the spool 26 can rotate on the locking plunger 50. If a user then pulls on the strap 14, it unwinds itself from the spool 26, this causes the torsion spring 74 to become wound, so tending
10 to oppose the unwinding from the spool 26. At any time, a user can release the locking plunger 50. The compression spring 72 causes the locking plunger to move back to its original position, in which it locks the spool 26 against rotation once again.

The way in which the device is used is shown in Figures 10, 11 and 12.

First, a user introduces the handles of a bag or bags into the hook portion 12 of the body 10, as
15 shown in Figure 10. The user then presses the locking plunger 50 into the body 10 and withdraws a length of the strap 14, as shown in Figure 11. The user can then place the strap over his or her shoulder, as shown in Figure 12, where it transfers the load that arises from the weight of the contents of the bags to the user's shoulder where it can be borne comfortably. When the user arrives at their destination and puts the bags down, he or she presses the
20 locking plunger 50 to allow the torsion spring 74 to wind the strap back onto the spool 26 (so withdrawing it into the body) and then releases the hook portion 12 from the bags. In this condition, a minimal length of the strap is out of the body 10 (less than shown in Figure 1) so that the device as a whole is compact and can be carried easily in a bag or a pocket.

Claims

1. Apparatus to assist a person carrying one or more bags comprising:
 - 5 a. a body having attachment means by which it can be connected to a bag to be carried;
 - b. a deployable strap that extends from a spool within the body to form a loop externally of the body, whereby the loop can be carried on a person's shoulder;
 - 10 c. a locking means within the body which can be operated by a user to selectively allow or prevent rotational movement of the spool and thereby allow or prevent retraction of the strap from the body;
 - 15 d. wherein the locking means includes a locking plunger that is coaxial with the spool, and which can move axially within the body between an unlocked position in which the spool can rotate about the locking plunger and locked position in which rotational movement of the spool with respect to the locking plunger is restricted, there being only limited or no rotational movement between the body and the locking plunger, when the locking plunger is in the locked position.
2. Apparatus according to claim 1 that includes biasing means that urges the locking plunger towards the locked position.
- 20 3. Apparatus according to claim 2 in which the biasing means includes a coil spring acting in compression between the locking plunger and the body.
4. Apparatus according to claim 3 in which the coil spring surrounds a portion of the locking plunger.

5. Apparatus according to any preceding claim in which, when in the locked position, a portion of the locking plunger projects from the body.
6. Apparatus according to claim 5 in which a user can apply manual pressure to the projecting portion to urge the locking plunger to the unlocked position.
- 5 7. Apparatus according to any preceding claim in which ribs and keyways of the locking plunger and the body are in interengagement to permit axial but substantially prevent rotational movement between the locking plunger and the body.
8. Apparatus according to any preceding claim in which the spool and the locking plunger carry teeth which interengage when the locking plunger is in the locked position and
10 which can move past one another during mutual rotation of the spool and the locking plunger when the locking plunger is in the unlocked position.
9. Apparatus according to any preceding claim in which the spool and the locking plunger can rotate with respect to one another when the locking plunger is in the locked position by substantially less than one complete turn.
- 15 10. Apparatus according to any preceding claim in which the spool and the locking plunger can rotate with respect to one another when the locking plunger is in the locked position by no more than 2 degrees.
11. Apparatus according to any preceding claim that includes retraction means for automatically winding the strap onto the spool.
- 20 12. Apparatus according to claim 11 in which the retraction means includes a helical spring.
13. Apparatus according to claim 12 in which energy is stored in the spring as the strap is withdrawn from the body.
14. Apparatus according to any preceding claim in which the body, the locking plunger and the spool are formed as one or more mouldings of plastic material.

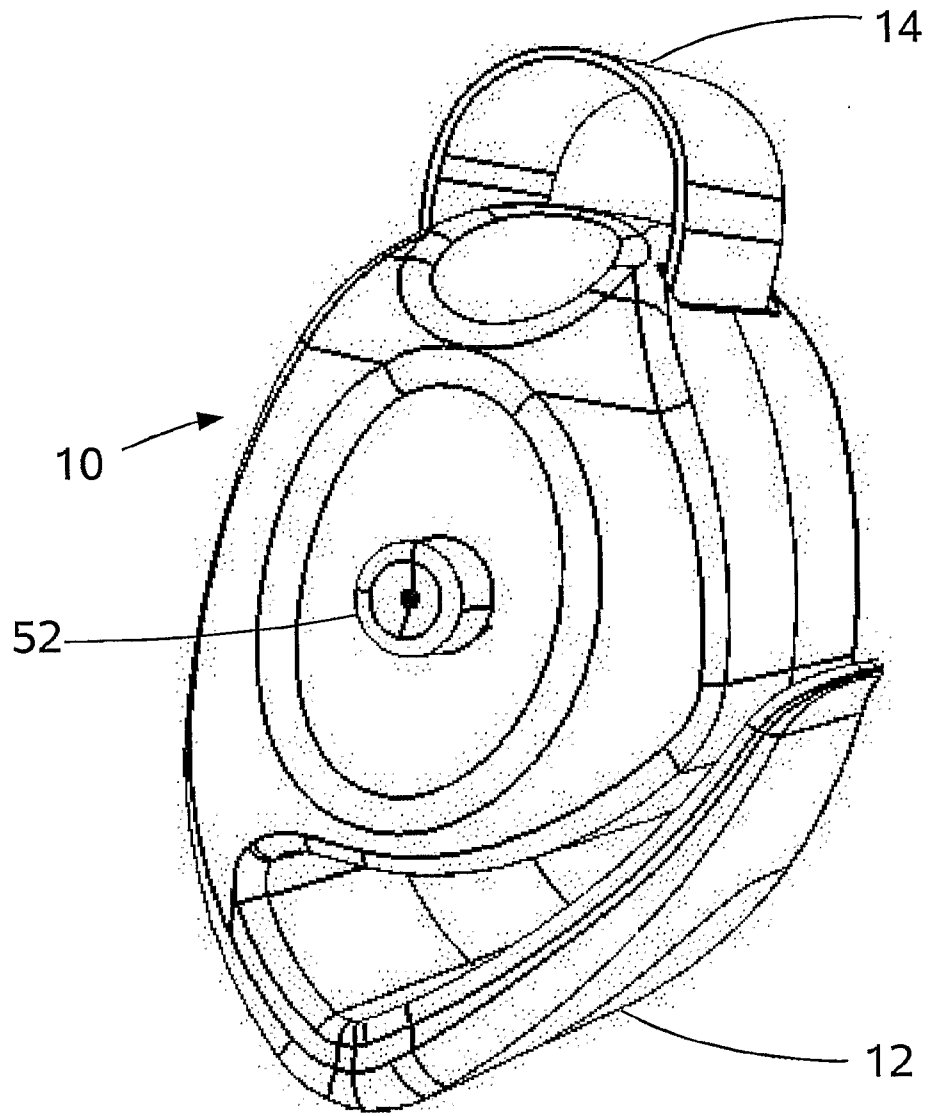

Fig 1

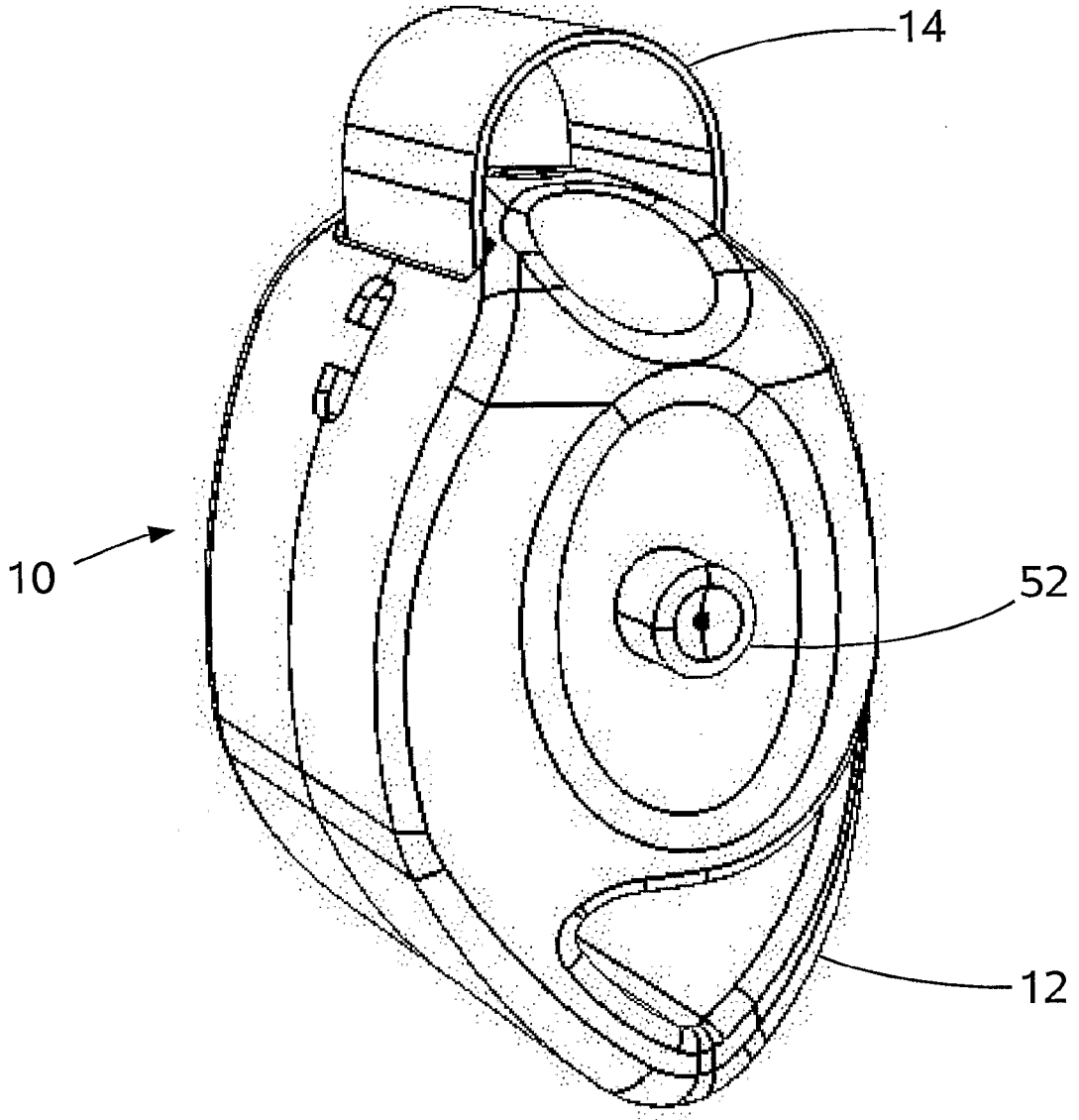

Fig 2

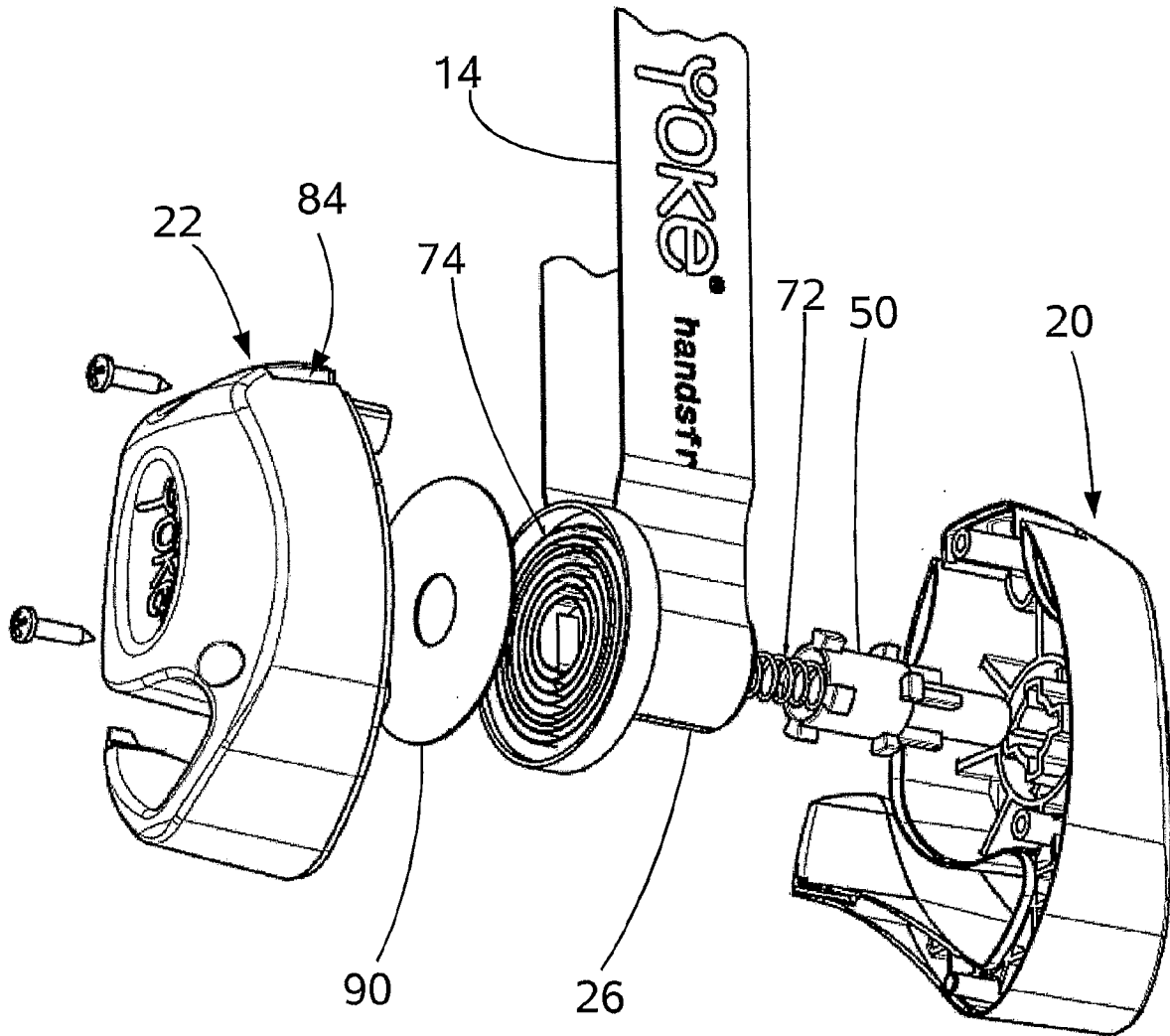

Fig 3

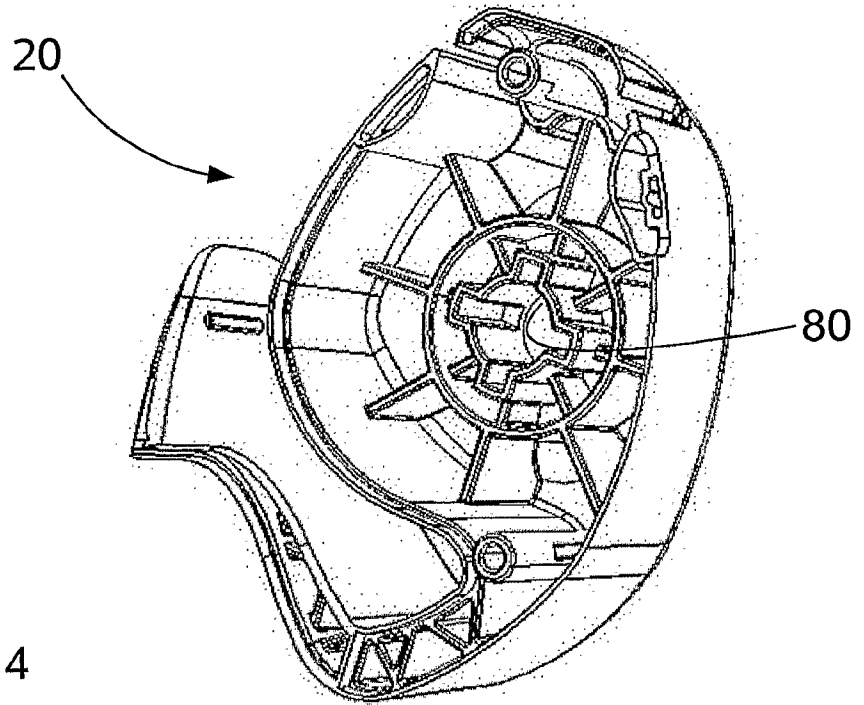

Fig 4

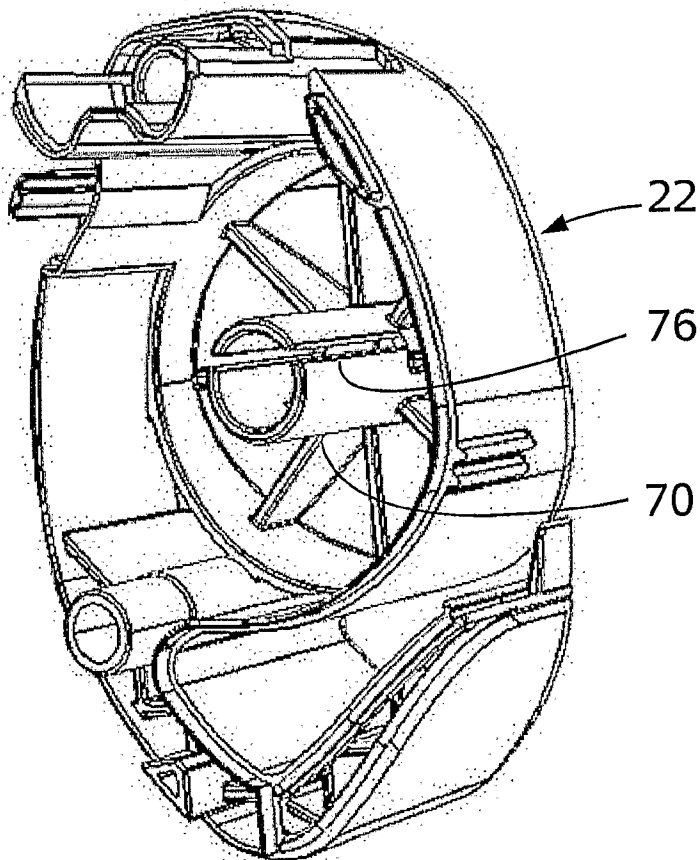

Fig 5

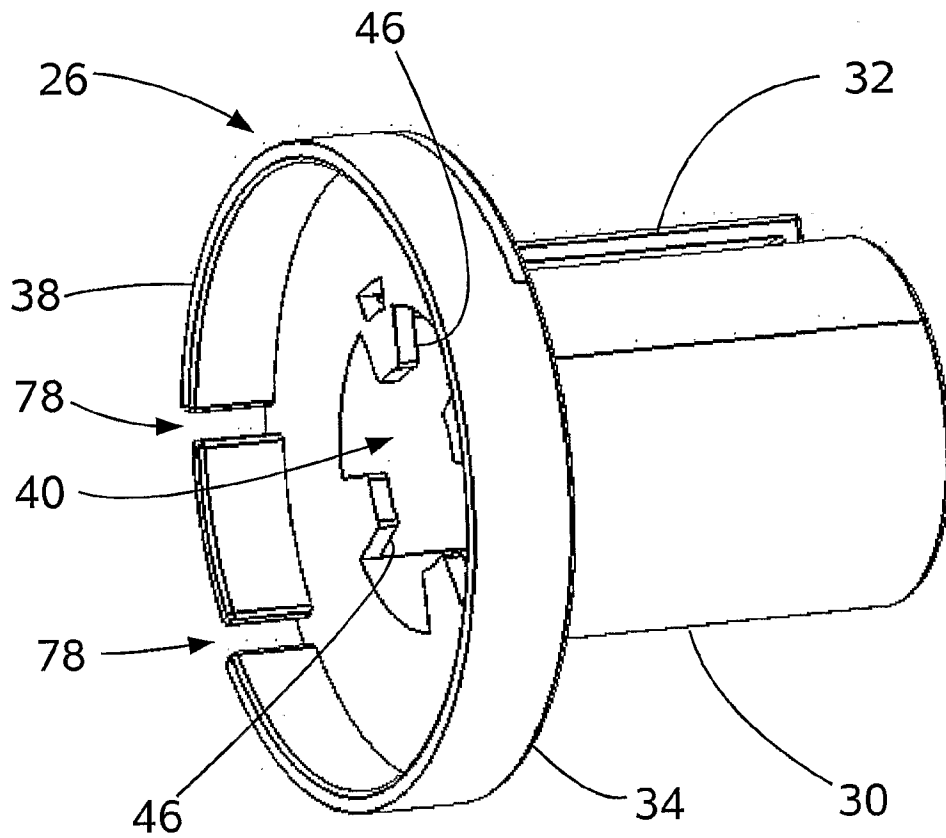

Fig 6

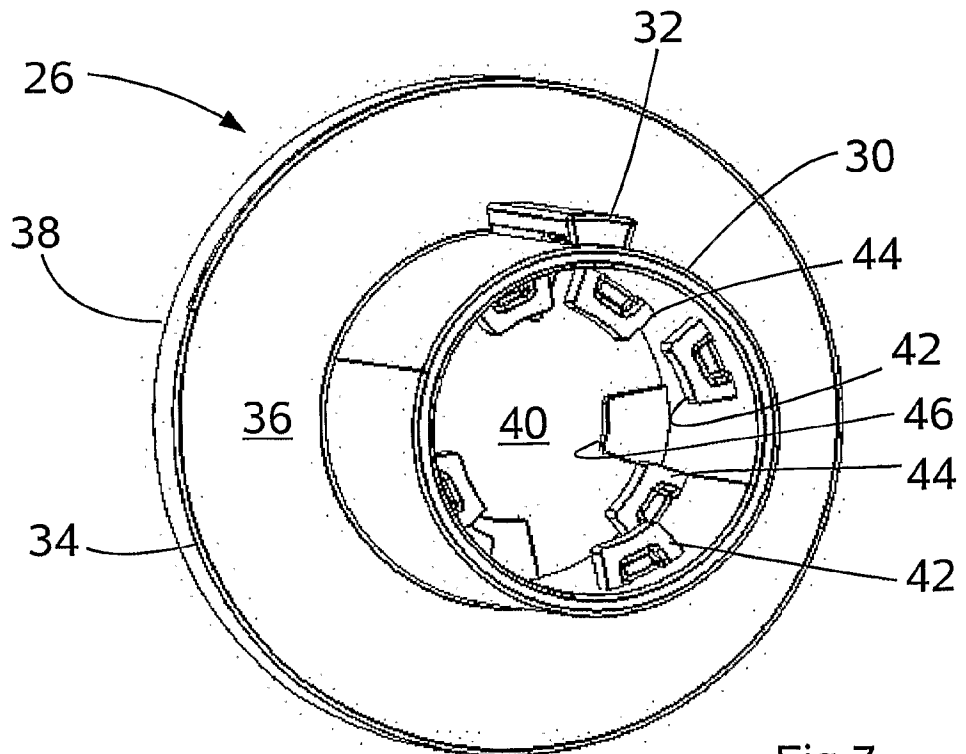

Fig 7

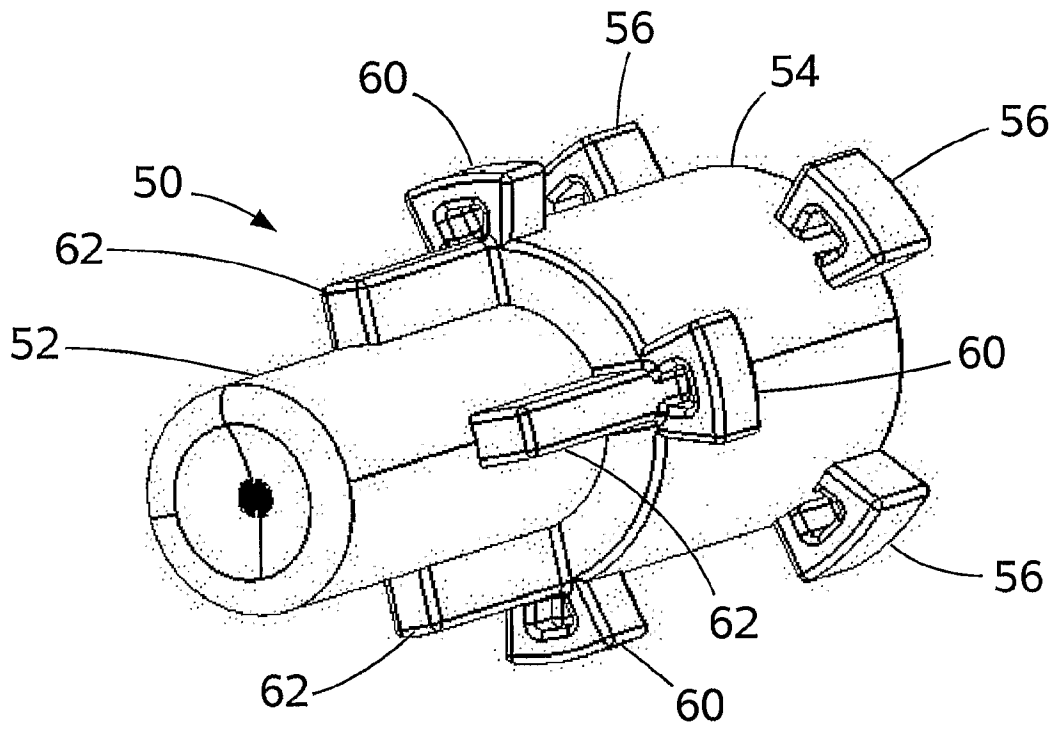

Fig 8

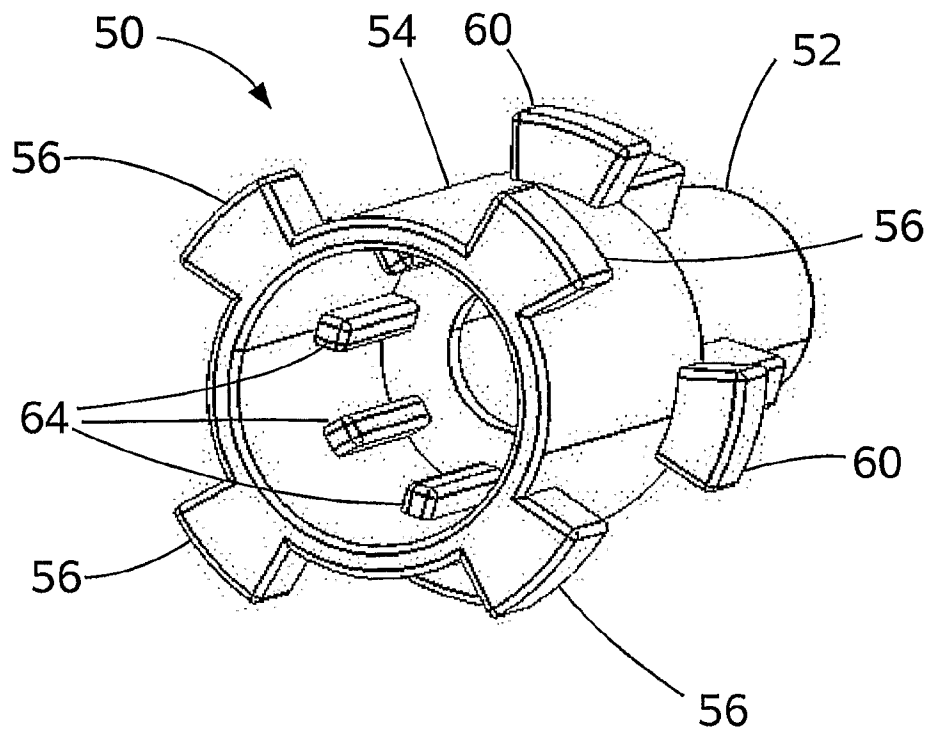

Fig 9

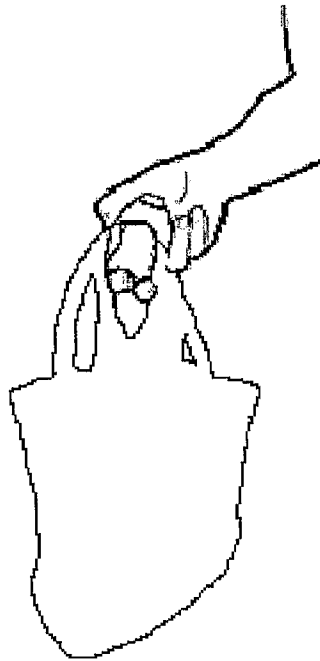

Fig 10

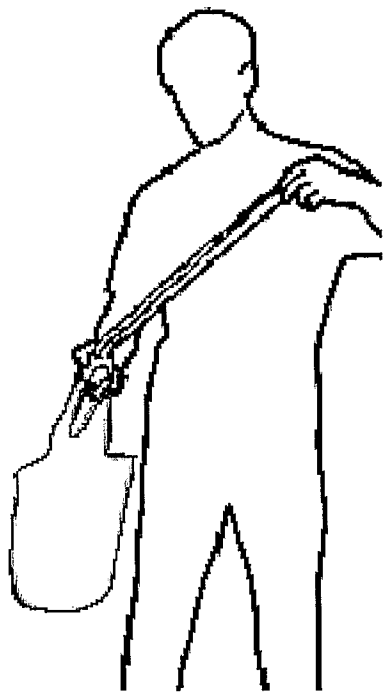

Fig 11

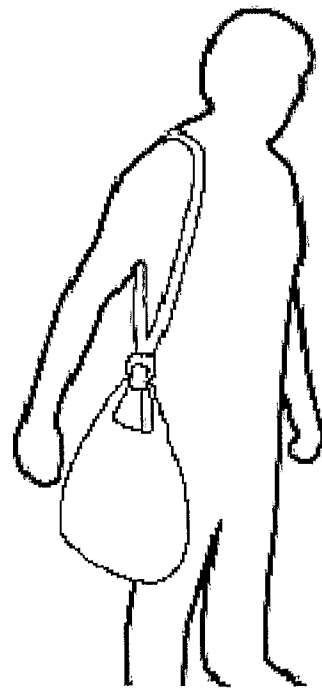

Fig 12

INTERNATIONAL SEARCH REPORT

International application No

PCT/GB2008/002691

A. CLASSIFICATION OF SUBJECT MATTER

INV. A45F5/00
ADD. A45F3/02

According to International Patent Classification (IPC) or to both national classification and IPC

B. FIELDS SEARCHED

Minimum documentation searched (classification system followed by classification symbols)

A45F

Documentation searched other than minimum documentation to the extent that such documents are included in the fields searched

Electronic data base consulted during the international search (name of data base and, where practical, search terms used)

EPO-Internal, WPI Data

C. DOCUMENTS CONSIDERED TO BE RELEVANT

Category*	Citation of document, with indication, where appropriate, of the relevant passages	Relevant to claim No.
X	US 5 897 039 A (SWENKE J KEVIN [US]) 27 April 1999 (1999-04-27) column 4, line 57 - column 7, line 26.	1-14
Y	FR 934 983 A (TAPAJ PETER) 7 June 1948 (1948-06-07) page 1, line 61 - page 2, line 81	1-14
Y	WO 03/099061 A (JANSPORT APPAREL CORP [US]; LIEBOWITZ MICHAEL [US]; PETRAVIC ROBIN [US]) 4 December 2003 (2003-12-04) page 9, line 26 - page 10, line 31	1-14

Further documents are listed in the continuation of Box C.

See patent family annex.

* Special categories of cited documents:

- *A* document defining the general state of the art which is not considered to be of particular relevance
- *E* earlier document but published on or after the international filing date
- *L* document which may throw doubts on priority claim(s) or which is cited to establish the publication date of another citation or other special reason (as specified)
- *O* document referring to an oral disclosure, use, exhibition or other means
- *P* document published prior to the international filing date but later than the priority date claimed

- *T* later document published after the international filing date or priority date and not in conflict with the application but cited to understand the principle or theory underlying the invention
- *X* document of particular relevance; the claimed invention cannot be considered novel or cannot be considered to involve an inventive step when the document is taken alone
- *Y* document of particular relevance; the claimed invention cannot be considered to involve an inventive step when the document is combined with one or more other such documents, such combination being obvious to a person skilled in the art.
- *G* document member of the same patent family

Date of the actual completion of the international search

17 November 2008

Date of mailing of the international search report

27/11/2008

Name and mailing address of the ISA/
European Patent Office, P.B. 5818 Patentlaan 2
NL - 2280 HV Rijswijk
Tel. (+31-70) 340-2040,
Fax: (+31-70) 340-3016

Authorized officer

Koob, Michael

INTERNATIONAL SEARCH REPORT

Information on patent family members

International application No

PCT/GB2008/002691

Patent document cited in search report.	A	Publication date	Patent family member(s)	Publication date
US 5897039	A	27-04-1999	WO 9953795 A1	28-10-1999
FR 934983	A	07-06-1948	NONE	
WO 03099061	A	04-12-2003	AU 2003245318 A1	12-12-2003
			CA 2486591 A1	04-12-2003
			MX PA04011413 A	15-08-2005
			TW 278292 B	11-04-2007