

No. 613,000.

Patented Oct. 25, 1898.

A. P. WEITZ.
VOTING MACHINE.

(Application filed Aug. 12, 1897.)

(No Model.)

4 Sheets—Sheet 1.

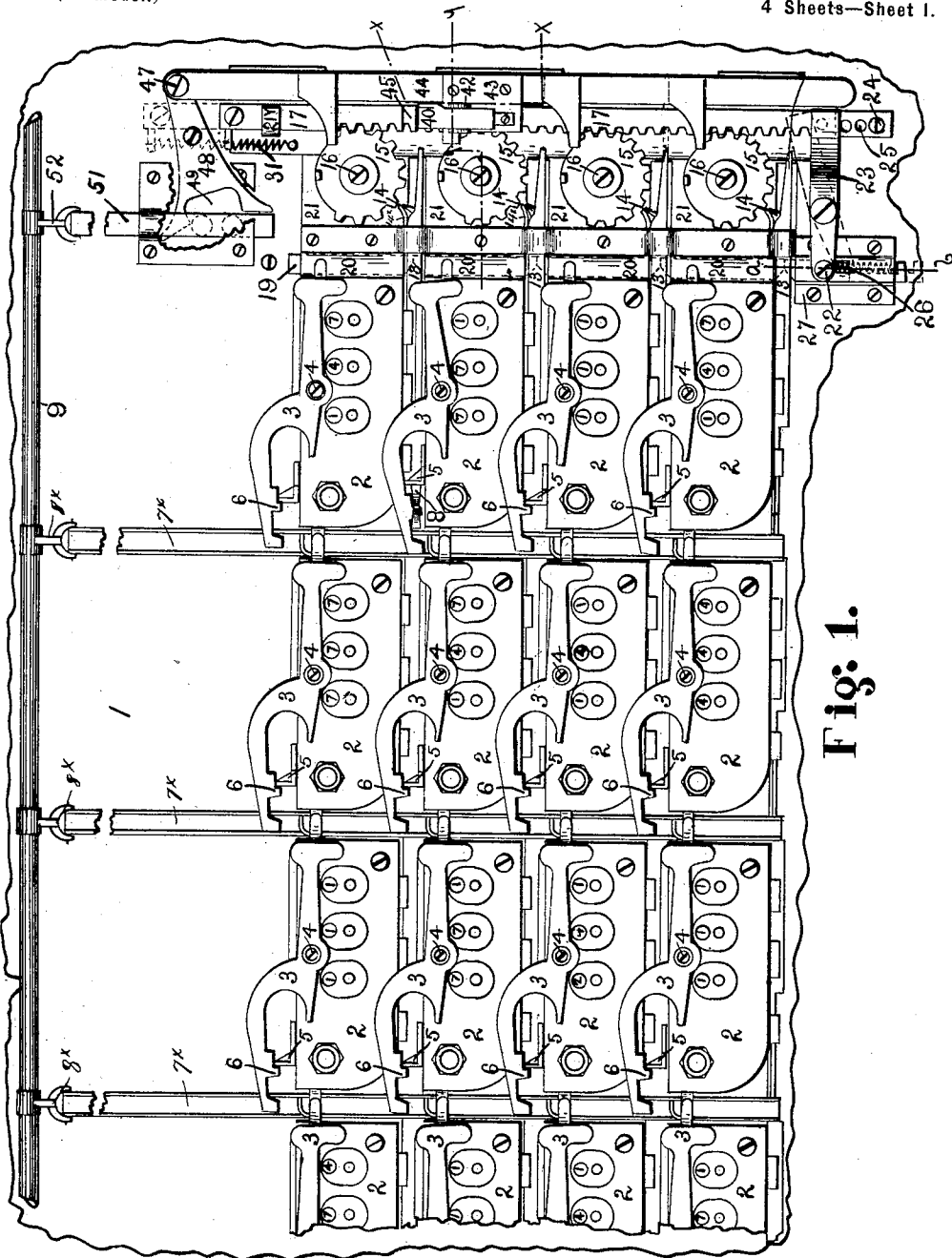

Fig. 1.

Witnesses.

W. W. Tuttle.
Grace A. Roda.

Inventor.

August P. Weitz
by *John H. Churchman*
his

Attorney

No. 613,000.

Patented Oct. 25, 1898.

A. P. WEITZ.
VOTING MACHINE.

(Application filed Aug. 12, 1897.)

(No Model.)

4 Sheets—Sheet 2.

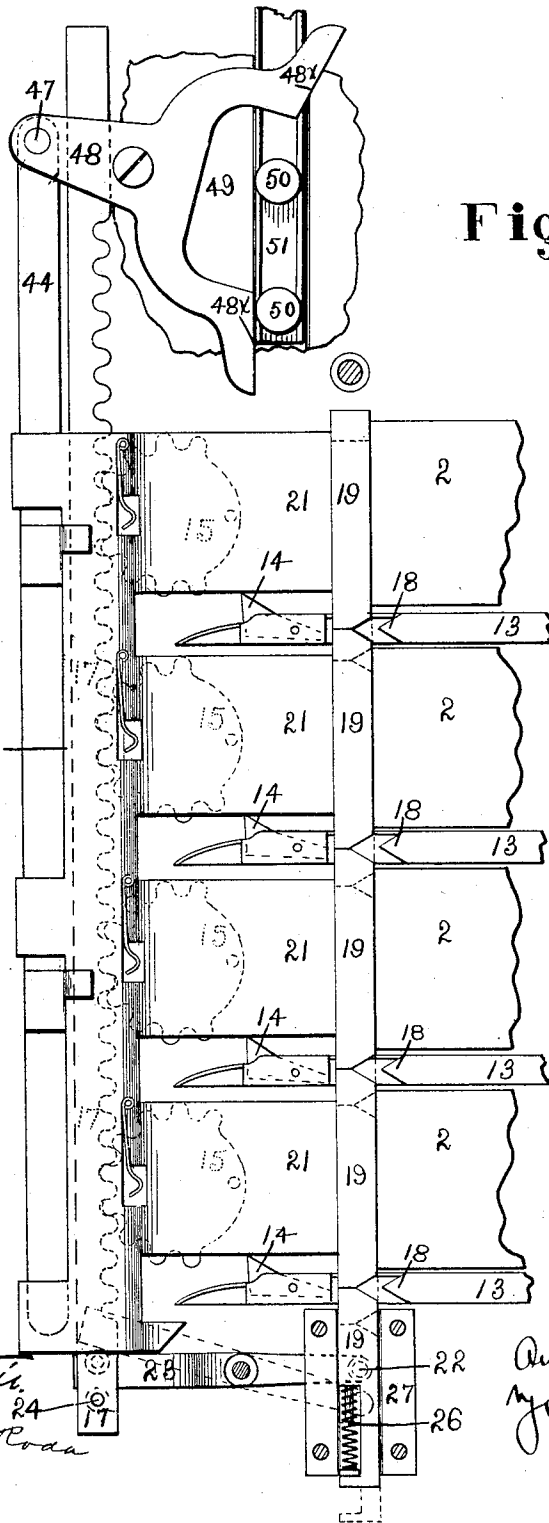

Fig. 2.

Witnesses.

A. W. Sullivan
24
Grace Road

Inventor.

August P. Weitz
by
Church & Church
his

Attorney

No. 613,000.

Patented Oct. 25, 1898.

A. P. WEITZ.
VOTING MACHINE.

(Application filed Aug. 12, 1897.)

(No Model.)

4 Sheets—Sheet 3.

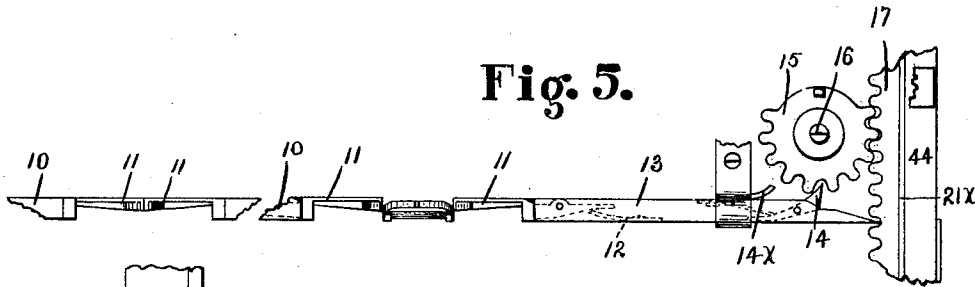

Fig. 5.

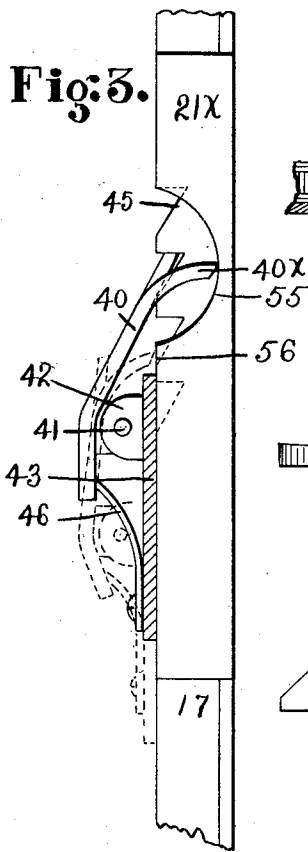

Fig. 3.

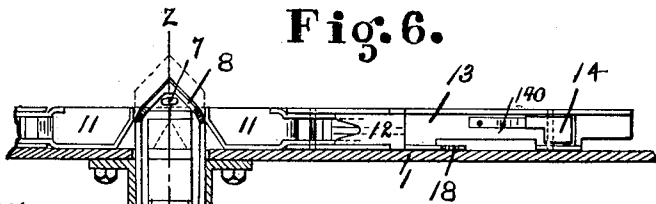

Fig. 6.

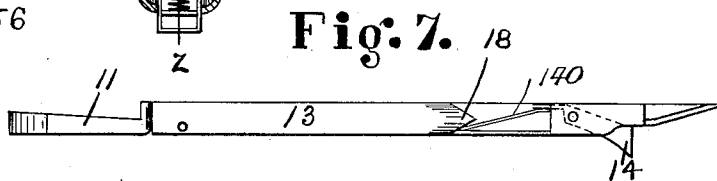

Fig. 7.

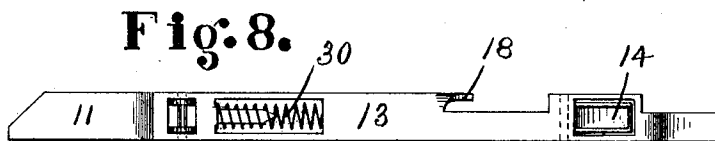

Fig. 8.

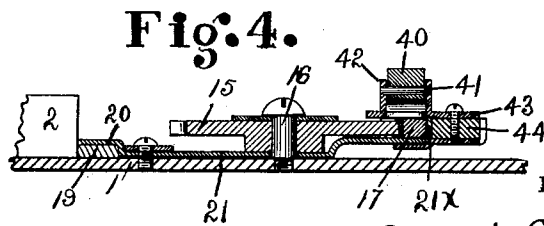

Fig. 4.

Witnesses.

H. L. Little
George Roda

Inventor.

August P. Weitz
Charles Edmund
his Attorney

No. 613,000.

Patented Oct. 25, 1898.

A. P. WEITZ.
VOTING MACHINE.

(Application filed Aug. 12, 1897.)

(No Model.)

4 Sheets—Sheet 4.

Fig:12.

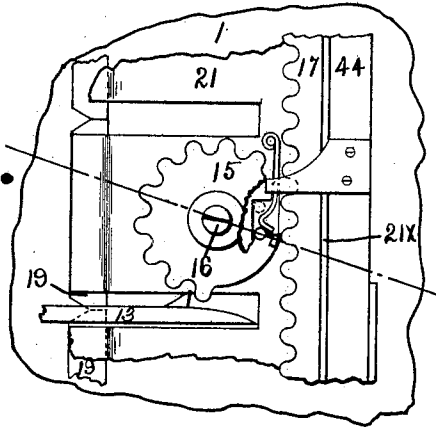

Fig. 9.

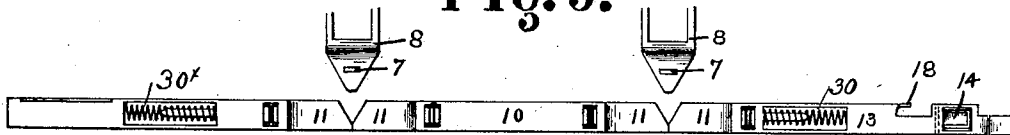

Fig. 13.

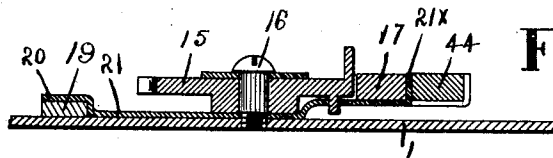

Fig. 11.

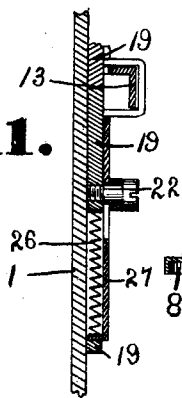
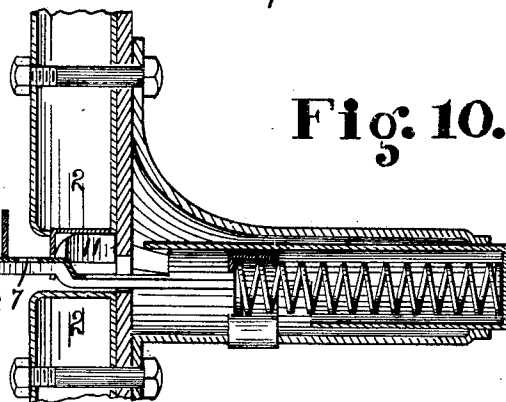

Fig. 10.



Witnesses.

W. L. Little
Grace A. Roda

Inventor.

August P. Weitz
by Charles O. Church
his Attorney

UNITED STATES PATENT OFFICE.

AUGUST P. WEITZ, OF ROCHESTER, NEW YORK, ASSIGNOR, BY MESNE ASSIGNMENTS, TO THE STANDARD VOTING MACHINE COMPANY, OF SAME PLACE.

VOTING-MACHINE.

SPECIFICATION forming part of Letters Patent No. 613,000, dated October 25, 1898.

Application filed August 12, 1897. Serial No. 647,993. (No model.)

To all whom it may concern:

Be it known that I, AUGUST P. WEITZ, of Rochester, in the county of Monroe, New York, have invented certain new and useful Improvements in Voting-Machines; and I do hereby declare the following to be a full, clear, and exact description of the same, reference being had to the accompanying drawings, forming a part of this specification, and to the figures of reference marked thereon.

My invention relates to ballot or voting machines particularly of the type known as the "Myers American ballot-machines," one form of which is contained in Letters Patent No. 494,588, granted April 3, 1893, to Jacob H. Myers; and it has for its object to improve the construction and operation of said machines, and more particularly of the devices known in the art as "multi-candidate" or "group" devices, whereby the voter may cast his ballot for a certain number of candidates for the same office—as, for instance, where there are three coroners to be elected and each of the four parties represented in the election nominates three candidates, twelve names are thus presented for the voter to choose from, and he is permitted to cast a ballot for any three and no more. Heretofore means have been provided in ballot-machines for accomplishing this result embodying sliding blocks having a limited movement between which ballot-indicating devices, as keys, are moved, the keys being retained after operation by suitable retaining devices, and when the total ballots indicated or cast in the group reach a certain predetermined number the blocks are locked from further operation and no more keys or indicators can be actuated until the machine is reset; but objection to this type of interlocking mechanism has been made on the ground that the key or indicator may be moved a short distance, and that there is a possibility, by reason of a slight lost motion between the blocks, of a voter exceeding the predetermined number of ballots he is permitted under the law to cast. By my improvements, however, which are shown herein as applied to an existing type of machines, it is impossible for the voter to exceed the number of ballots he is entitled to vote, the indicators or keys

becoming positively locked after the proper number have been cast.

The invention further has for its object to improve the construction of the parts whereby they are cheapened and multiplied; and it consists in the improvements hereinafter described, the novel features being pointed out particularly in the claims at the end of this specification.

In the drawings, Figure 1 is a rear elevation of the plate of a ballot-machine which carries the counters and voting appliances; Fig. 2, a view of the other side of the grouping devices shown, looking from the supporting-plate, which latter has been removed; Fig. 3, a vertical sectional view taken on the line *x x* of Fig. 1; Fig. 4, a cross-sectional view taken on the line *y y* of Fig. 1; Fig. 5, a view of one of the key-actuated blocks or slides and a portion of the grouping device during the actuation of the key; Fig. 6, a bottom plan view showing the operation of one of the keys or indicators; Fig. 7, a rear view, and Fig. 8 a plan view, of one of the end blocks or slides of the horizontal series; Fig. 9, a plan view showing a series of indicators and interlocking blocks between them; Fig. 10, a vertical sectional view on the line *z z* of Fig. 6; Fig. 11, a similar view on the line *a b* of Fig. 1. Figs. 12 and 13 are views of details.

Similar reference-numerals in the several figures indicate similar parts.

I have shown my invention as applied to the well-known Myers American ballot-machine, 1 indicating the plate or support, to the rear side of which the counting or registering devices and the interlocking devices between the various indicating-keys are applied.

2 indicates the counters, of any suitable type, secured to the rear side of the plate in any suitable manner, one counter being devoted to each candidate and the counters in the same vertical row being devoted to candidates of the same political party and the counters for candidates for the same office being located in the three lower horizontal rows. The top row of counters (shown in Fig. 1) does not relate to the group device forming the subject-matter of my present invention. Each of the counters is provided with an ac-

tuator 3 in the form of a lever, pivoted at 4 to the casing, and one end of said lever is normally supported upon a spring-projected slide 5 and has a projection 6, adapted to enter an aperture 7, formed in the spring-retracted key or ballot-indicator 8, so that when the key is pushed inward the slide will be moved laterally and the end 6 of the actuator will drop into the aperture and retain the key, preventing a second operation until the key is released. The other end of the actuator 3 is adapted to be connected operatively with the registering-wheels of the counter when the key is pressed inward, and when the actuator is returned to normal position, releasing the key, one vote or unit will be registered for the candidate to whom the counter is devoted.

The means employed for returning the actuators and counting the votes for each of the candidates indicated embodies the vertically-movable rods 7^x, pivoted to arms 8^x on the rock-shaft 9, which latter is, as usual in machines of this type, operated when the voter leaves the proximity of the indicators or keys either by opening of the exit-door of the booth or otherwise. The inner ends of the keys or indicators are pointed, as usual, for the ready passage between the interlocking blocks, and the extreme inner ends of the said keys are preferably in a higher plane than the portions just back of said ends. The sliding blocks 10 are arranged between the keys in the same horizontal row and are each provided at the ends with hinged or latched portions 11, adapted to yield vertically, the proximate ends of these latches being beveled, as shown in Fig. 6. Springs 12, cooperating with the rear ends of the latches, normally hold the latter down to the position shown in Fig. 5, so that when a key is thrust inward the blocks in the horizontal row will be separated, preventing the simultaneous entrance of another key in the same row, and when the elevated head of the key has passed beyond the ends of the blocks the latter are brought together behind it by springs 10^x, operating on the end blocks of the series. The latched ends of the sliding blocks permit the simultaneous retraction of the keys when the machine is reset, the inclined back of the heads passing beneath the latches and said latches yielding vertically, as will be understood.

The blocks or slides 13 at the ends of the horizontal rows are made, preferably, of sheet metal and are each provided with a pawl 14, adapted when the block is moved to the left to cooperate with the mutilated gear 15, mounted upon a pin or screw 16 and meshing with a rack-bar 17, the latter constituting a movable member, to which motion is communicated by the operation of any of the indicating-keys in the group.

The pawls 14 are provided with operating springs 140, which tend to operate their ends upward to engage the teeth of the gears 15; but when the blocks are moved by the springs

30 to the left, Fig. 1, said pawls are held downward against the tension of the springs 140 by the lugs or arms 14^x.

Each of the end blocks 13 is further provided with a pointed extension 18 on its rear side, (shown particularly in Figs. 2, 7, and 8,) which projection cooperates with a series of vertically-sliding blocks 19, operating between flanges 20 on a plate 21 and the rear side of the plate or support 1. These blocks have beveled ends, and the lowermost block of the series is pivoted at 22 to one end of the lever 23. The other end of said lever projects over the lower end of the rack-bar 17 and in position to be engaged by an adjustable screw or pin 24, screwed in any of the apertures 25 of said rack-bar. The vertical series of blocks are supported upon a spring 26, cooperating with the lower one and with the guide-plate 27, secured to the support 1, the tension of said spring, combined with the weight of the lever 23, being sufficient to keep the blocks in the position shown in Fig. 2, with their beveled ends in alinement with the beveled projections 18 on the end blocks of the horizontal series, from which construction it will be seen that when any ballot-indicating key is thrust inward the horizontal row of sliding blocks will prevent another key of the same horizontal row from being moved inward, and the projection 18 on the end block of the horizontal row passing between the blocks 19 will separate the latter and throw the beveled ends on all the other blocks in the series out of alinement with the projections 18 on the other end blocks, so that a simultaneous inthrust of two keys in the same or different horizontal rows is effectually prevented. After the keys have passed inward, so that their heads are beyond the end of the horizontal sliding blocks, the latter will be brought together again by the springs 30 and 30^x, the latter being attached to the end blocks 13, as shown in Fig. 8, and the former operating in the block at the other end of the row, as shown in Fig. 9. The extreme ends of the blocks 13 are extended beyond the pawls 14, so that while the key is being moved inward the extended end will enter between two of the teeth of the rack-bar 17 and prevent the operation of said bar more than the distance of one tooth, so that the voter may not by striking the key a quick hard blow cause the rack to jump more than one unit or the distance of one tooth.

The rack member 17 is normally moved downward by a spring 31, attached to its upper end, and its upward movement is against the tension of said spring. The amount of movement permitted the rack member 17 before it is arrested depends upon the number of candidates for which the voter is entitled to cast a ballot, and this is regulated by the adjustment of a screw 24 in the aperture at the lower end of said bar, the construction being such that when the required number (three in the present instance) of ballots have

been cast the screw 24 will engage the end of the lever 23, moving the latter as in dotted lines, dropping the blocks 19, so that their beveled ends will be out of alinement with the projections 18 on the horizontal sliding blocks, thereby preventing the operation of any more keys connected in the group devices. The rack member is guided in its vertical movements on one side by a flange 21^x on the plate 21 (see Fig. 4) and at its upper end by a small guide-plate 21^y, (see Fig. 1,) and it is held elevated after the actuation of any of the ballot-keys by means of pawl 40, pivoted at 41 upon ears 42, formed upon or attached to plate 43, secured to a vertically-sliding bar 44, said pawl cooperating with ratchet-teeth 45, formed on the front side of the rack-bar 17.

46 indicates a spring for holding the pawl 40 in engagement, permitting a vertical movement of the rack-bar and retaining it when operated. The upper end of the bar 44 is pivoted at 47 to the end of a pivoted lever 48, said lever having an opening 49 formed therein that cooperates with the projections 50, secured to the vertically-sliding rod 51, connected by an arm 52 with the rock-shaft 19. The pawl 40 is also provided with an arm 40^x, which when the bar 44 is in normal position projects in a recess 55 in a flange of the plate 21^x, thereby allowing the pawl to engage with the ratchet-teeth in the rack-bar 17 and hold the latter, but at the lower portion of this recess is a shoulder 56, which, when the bar 44 is dropped to the position shown in Fig. 3 in dotted lines, will engage the arm 40^x and lift the pawl out of engagement, allowing the rack-bar 17 to drop to lowermost position, thus releasing the blocks 19 and resetting the machine for another voter.

The lever 48 is provided with the flat surfaces 48^x on opposite sides of the recess 49, so that the rod 51 holds the lever positively in either elevated or depressed position.

By adjusting the pin 24 in the rack-bar it will be seen that the grouping device can be set so that one or any number of ballots can be cast, only limited by the number of apertures 25 and the ratchet-teeth on the bar 17. This locking the vertical series by moving the blocks 19, so that the solid portions will be presented to the projections 18, is an improvement on locking the blocks from operation, as the lost motion incident to the movement of the inclined ends between the beveled ends of the projections is prevented.

As far as the operation of this feature of my invention is concerned it could well be adapted to another type of machine, a part equivalent to the block 13 being employed as the indicator or key—that is to say, if one of the end blocks 13 were operated directly as a key or indicator the series of indicators represented by the vertical line of blocks 13 would be locked out after the operation of a predetermined number by the bodily movement of the blocks with their abutting ends

out of alinement with the projections that pass between them.

The parts composing my invention are simple and may be readily made of stamped metal and assembled by an unskilled operator, and the parts when assembled will insure the proper and accurate registration of the ballots cast.

It will be understood that the counters shown are simply one form of registering device with which the invention may be used, and that other forms may be applied and different means employed for registering the votes, as will be understood by those skilled in the art. For instance, instead of the actuators, which count the votes after the voter leaves the booth, the slides 5 could be arranged to operate the counters directly, as in the patent to Myers, No. 494,588, dated April 4, 1893.

I claim as my invention—

1. In a voting-machine the combination with two or more series of ballot-indicators, and blocks arranged between the indicators in each series preventing the operation of more than one at a time, the end block of each series having a pawl, a gear for each series with which said pawl cooperates and connections between the gears for causing their simultaneous operation, of sliding blocks 19, arranged between the blocks of the several series for preventing the simultaneous operation of indicators in different series, and adjustable connections between the gears and the series of blocks 19 whereby upon the operation of a predetermined number of indicators the blocks 19 will be moved with their abutting ends out of alinement with the blocks of the series substantially as described.

2. In a voting-machine the combination with two or more series of ballot-indicators, and blocks arranged between the indicators in each series to prevent the operation of more than one at a time, a movable part 13, as a block for each series and a progressively-movable member adapted to be actuated by any of the parts 13, of a series of movable blocks 19 between which the parts 13 move and serving to prevent the simultaneous operation of two indicators in different series, and connections between the progressively-movable member and the blocks 19, for moving the latter out of alinement with the parts 13, when a predetermined number of indicators have been actuated, substantially as described.

3. In a voting-machine, the combination with a plurality of series of ballot-indicators, the movable blocks between the indicators of each series, the blocks 13, a series of movable blocks 19 with their abutting ends in alinement with the blocks 13, and preventing the simultaneous operation of indicators in different series, of a progressively-movable member actuated by the movement of any indicator, and adjustable connections between said member and the blocks 19 for moving

the latter with their ends out of alinement with the blocks 13 after the operation of a predetermined number of indicators in any of the series.

5 4. In a voting-machine the combination with a plurality of series of ballot-indicators, of the blocks between the indicators of each series for preventing the operation of more than one at a time, the blocks 13, a progressively-movable member actuated by the movement of any indicator, a series of movable blocks 19 having their meeting edges in alinement with the blocks 13, the lever for moving said blocks 19 with their edges out of alinement and adjustable connections between the lever and movable member for operating the former after the operation of a predetermined number of indicators.

20 5. In a voting-machine the combination with a ballot-indicator, a block actuated thereby, and a spring for returning the block after actuation, the pawl on the block, the toothed wheel and the rack meshing therewith, of the retaining device for the rack, and the extension on the block to engage the rack.

25 6. In a voting-machine the combination with ballot-indicating keys, a series of blocks 13, each having a pawl, and a projection 18 thereon, of the blocks 19, means for holding the blocks with their abutting edges in alinement with the projections 18, the toothed wheels, the rack, the lever connected to the one of the blocks 19, an adjustable stop between the rack and lever, substantially as described.

35 7. The combination with a series of ballot-indicators and a series of projections operated thereby, a series of movable blocks between which the projections operate and 40 means for maintaining their abutting edges

normally in line with the projections and arranged to prevent the simultaneous operation of two or more of said indicators, of devices for moving the whole series of blocks with their abutting edges out of alinement with the aforesaid projections, and mechanism operating the last-named devices and controlled by the movement of the indicators for so moving said blocks after a predetermined number of indicators have been operated, whereby the bodies of the blocks will be presented to the projections and further operation of the indicators will be prevented.

8. In a voting-machine the combination with the wheels and the rack meshing with them, of the movable blocks having the pawls engaging the wheels and the extended end adapted to project between the teeth of the rack.

9. In a voting-machine the combination with the wheels and the rack meshing with them, of the pawl for holding the rack, movable blocks having the pawls engaging the wheels and the extended end for engaging the rack, and means for releasing the pawl holding the rack.

10. In a voting-machine the combination with ballot-indicators, of abutting movable blocks actuated by the indicators and operating by their separation to prevent the operation of more than a single indicator at a time, and means for moving the whole series of blocks bodily to prevent the operation of any indicator, after the operation of a predetermined number.

AUGUST P. WEITZ.

Witnesses:

F. F. CHURCH,
G. W. RICH.