



US00D477660S

(12) **United States Design Patent**
Pampalona Gelonch et al.

(10) **Patent No.:** **US D477,660 S**

(45) **Date of Patent:** **** Jul. 22, 2003**

(54) **CAR AIR FRESHENER**

D435,898 S 1/2001 Yang
6,302,559 B1 10/2001 Warren
D456,886 S 5/2002 Hart et al.
D460,170 S 7/2002 Hart et al.
D462,432 S 9/2002 Robson

(75) Inventors: **Ramon Pampalona Gelonch**, Lleida (ES); **Marc Richart Orgilles**, Lleida (ES)

(73) Assignee: **Lebo S.A.**, Torres de Segre (ES)

(**) Term: **14 Years**

Primary Examiner—M. H. Tung
(74) *Attorney, Agent, or Firm*—Staas & Halsey LLP

(21) Appl. No.: **29/162,179**

(22) Filed: **Jun. 12, 2002**

(30) **Foreign Application Priority Data**

Dec. 12, 2001 (ES) 152969

(51) **LOC (7) Cl.** **23-04**

(52) **U.S. Cl.** **D23/368**

(58) **Field of Search** D23/366-9; 422/120, 422/122-4; 239/34-60, 211, 53-6

(56) **References Cited**

U.S. PATENT DOCUMENTS

D385,024 S 10/1997 Roberts
D435,897 S 1/2001 Wu

(57) **CLAIM**

The ornamental design for car air freshener, as shown and described.

DESCRIPTION

FIG. 1 is a perspective view of the car airfreshener showing our design;
FIG. 2 is a front view thereof;
FIG. 3 is a rear view thereof;
FIG. 4 is a right side view thereof;
FIG. 5 is a left view thereof;
FIG. 6 is a top view thereof; and,
FIG. 7 is a bottom view thereof.
The broken line drawing of fluid in FIGS. 1-5 is for illustrative purposes only and forms no part of the claimed design.

1 Claim, 5 Drawing Sheets

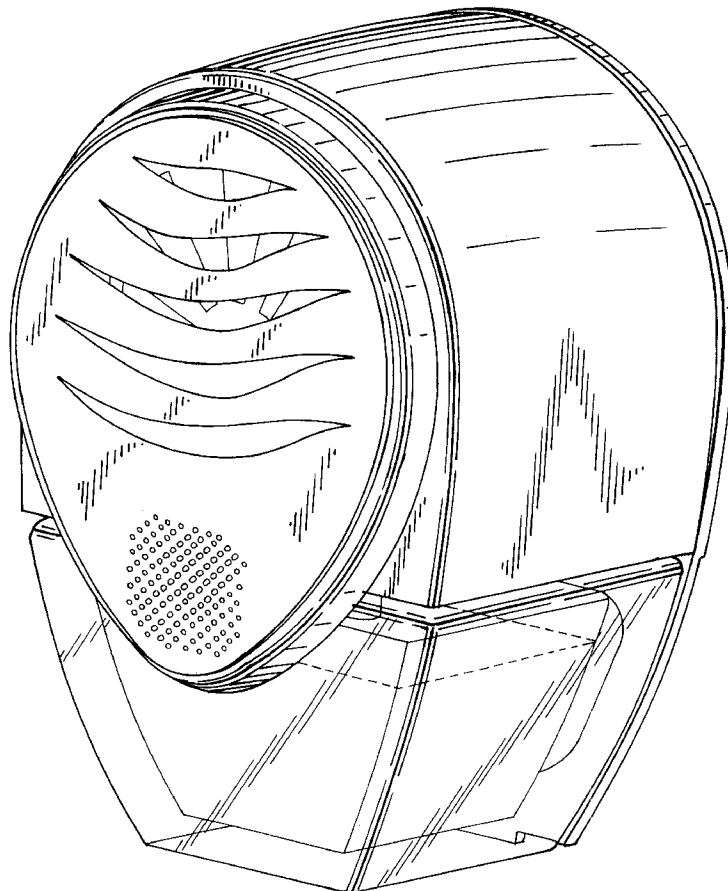

FIG. 1

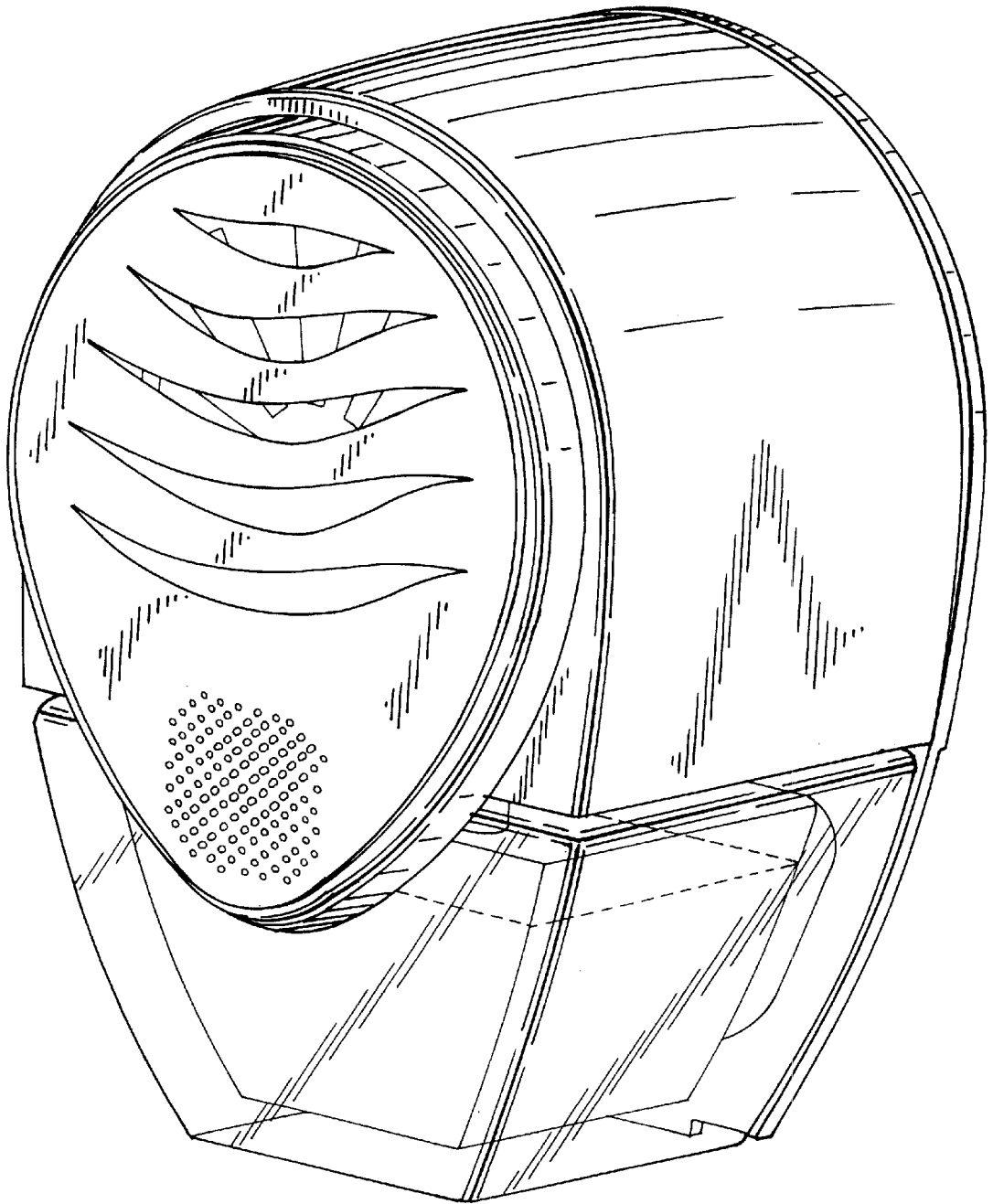

FIG. 3

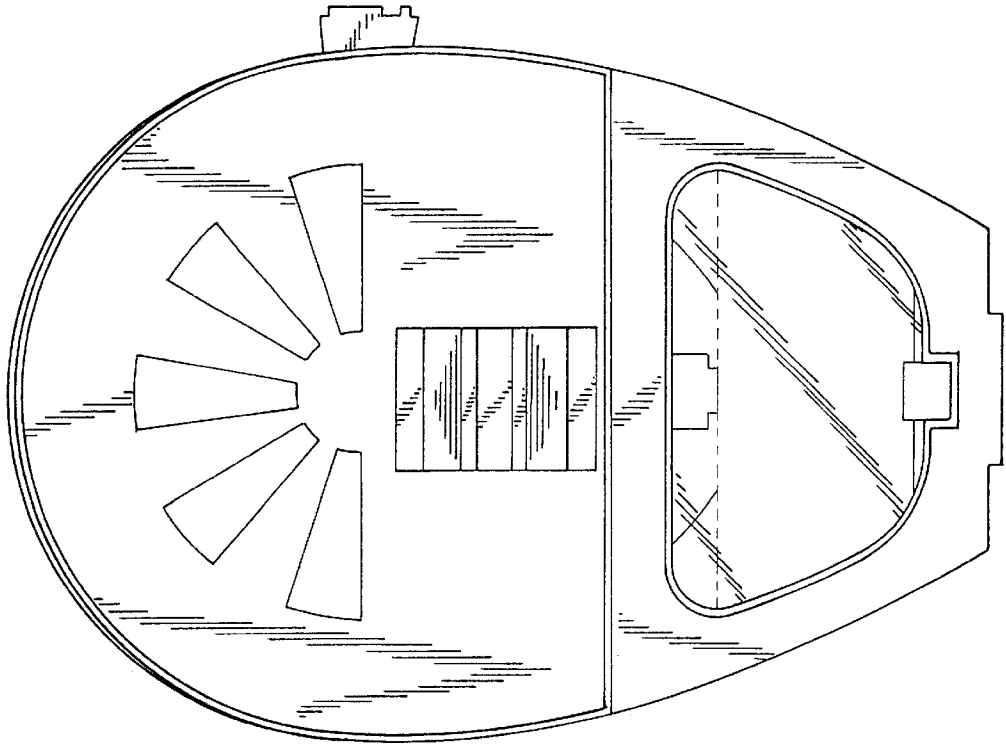

FIG. 2

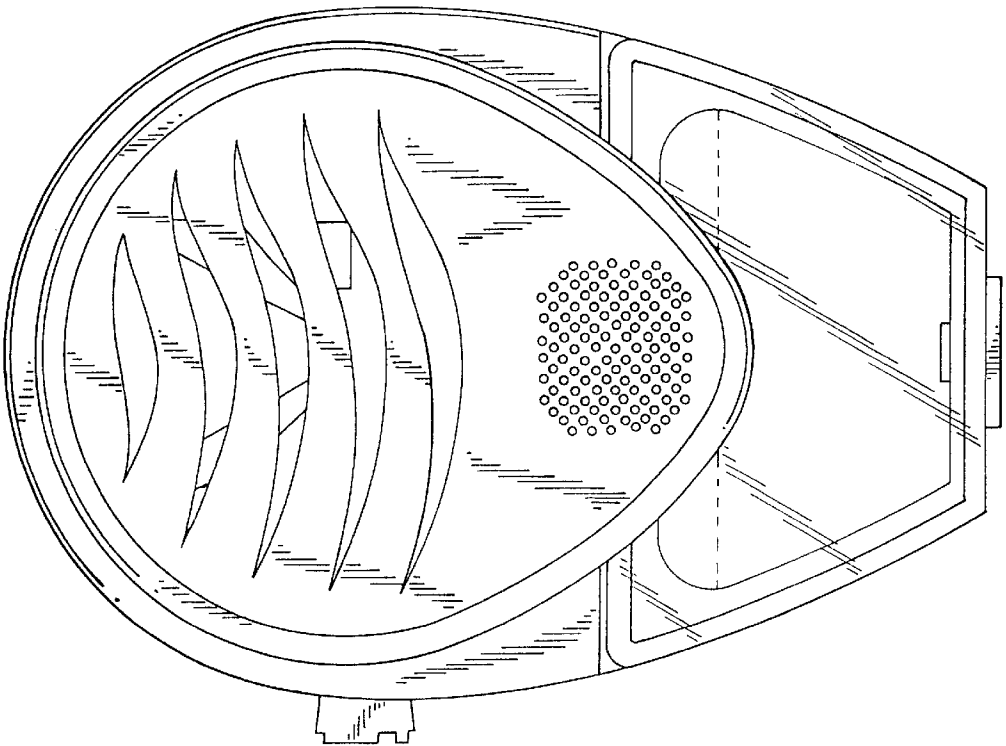

FIG. 4

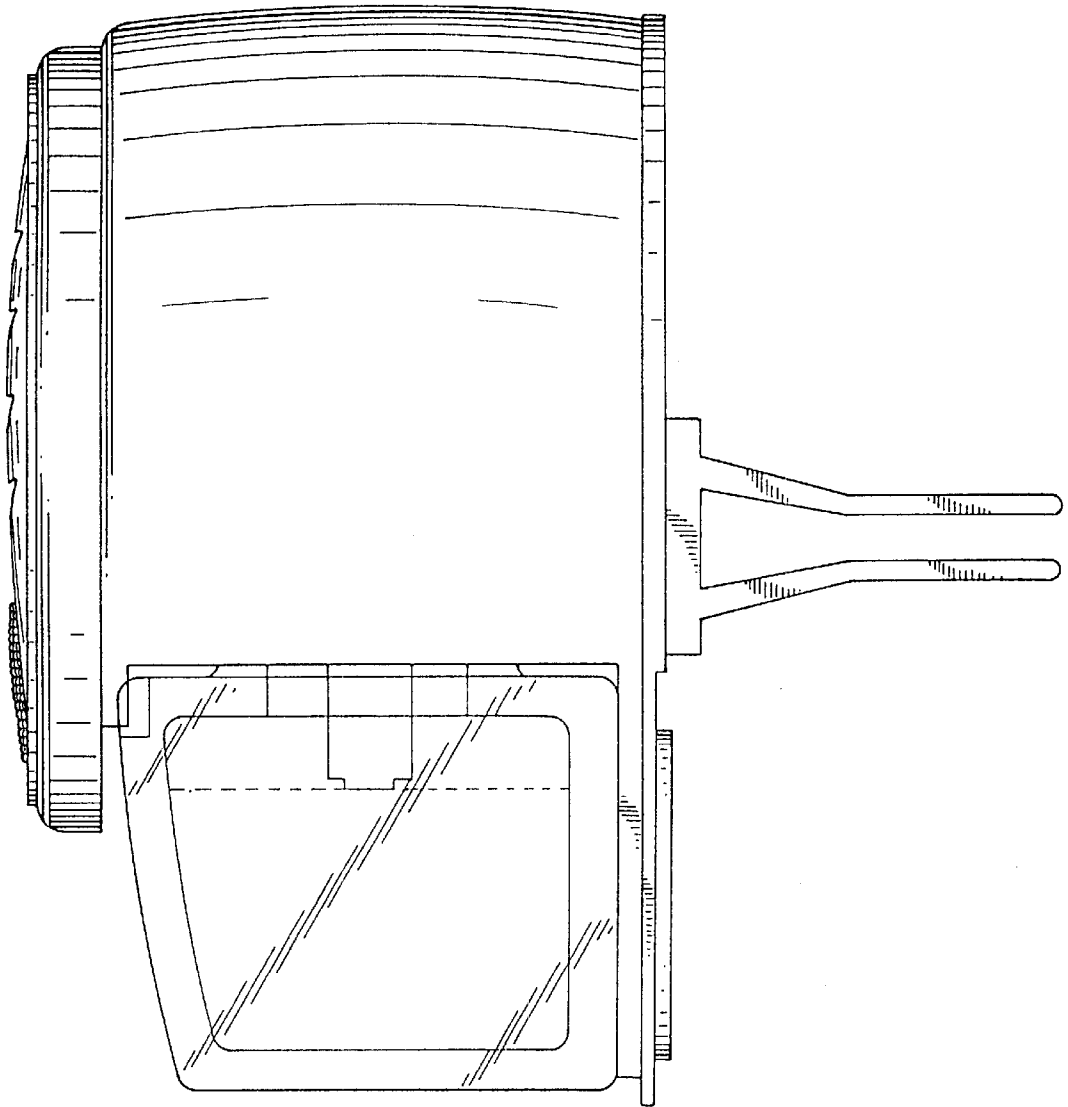
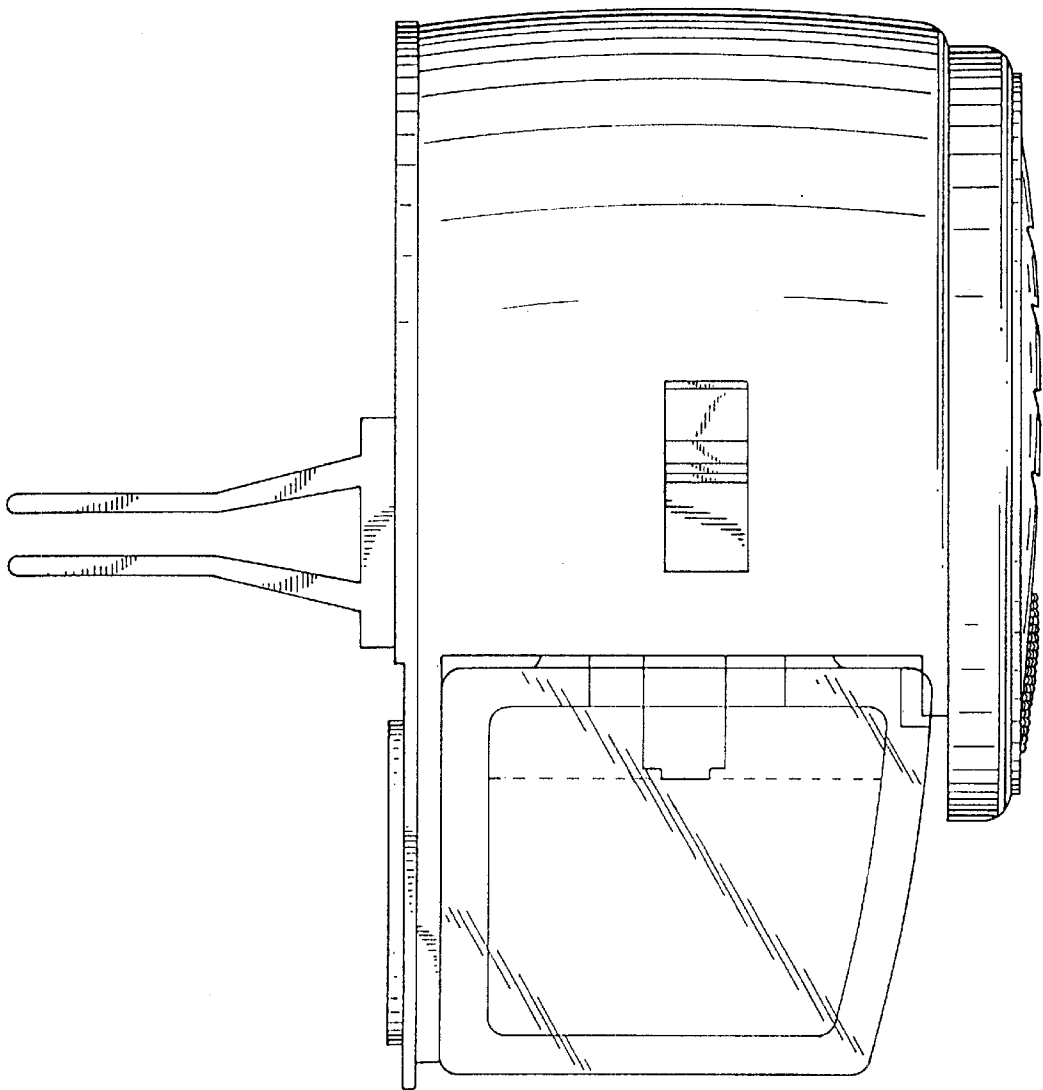

FIG. 5



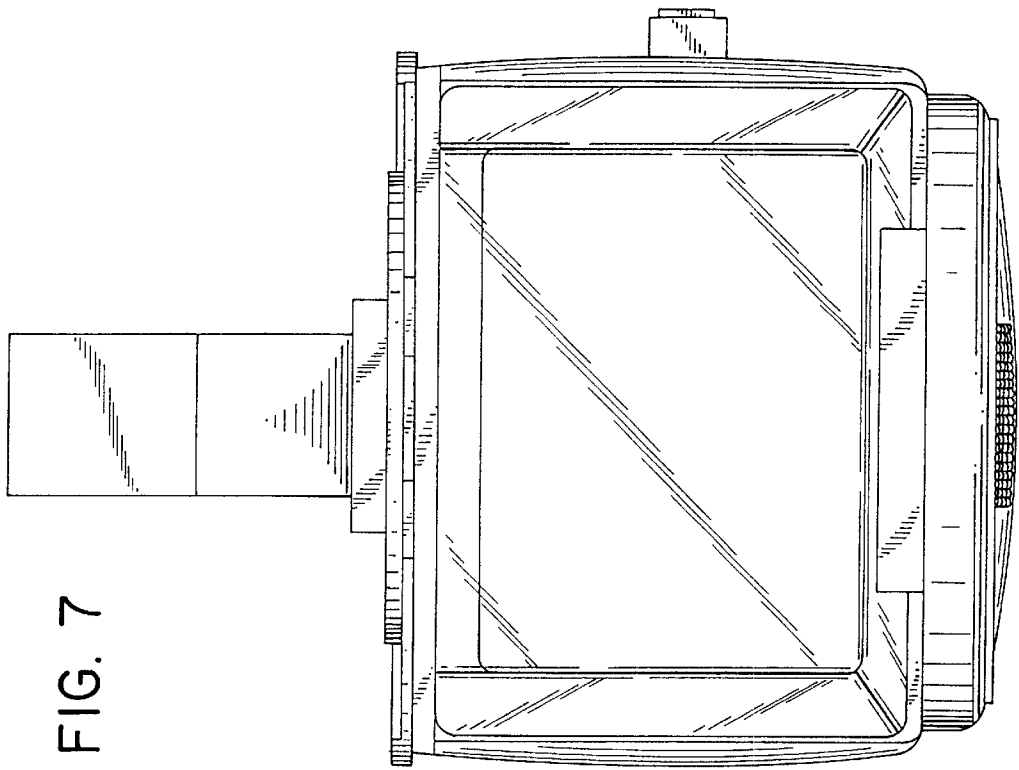

FIG. 7

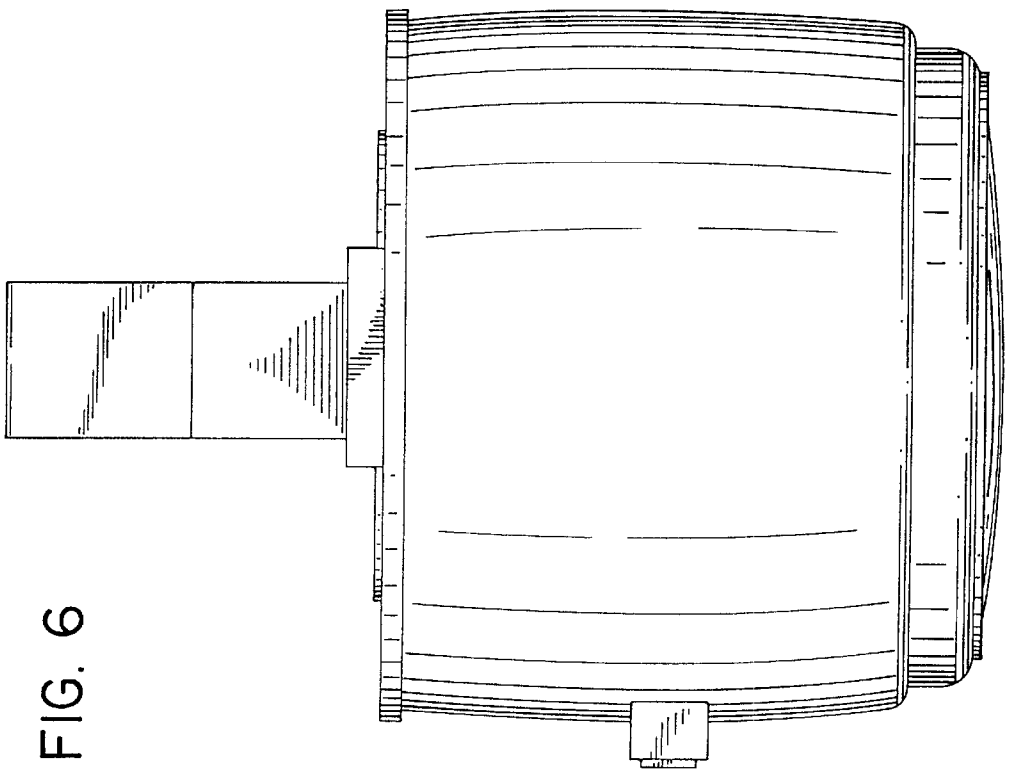

FIG. 6