



US00D778975S

(12) **United States Design Patent**
Minn et al.

(10) **Patent No.:** **US D778,975 S**

(45) **Date of Patent:** **** Feb. 14, 2017**

(54) **TRIPOD FOR AN ELECTRONIC DEVICE**

FOREIGN PATENT DOCUMENTS

(71) Applicant: **Kenu, Inc.**, San Francisco, CA (US)

CH 141045-0001 11/2014
CH 141045-0002 11/2014

(72) Inventors: **Kenneth Y. Minn**, San Francisco, CA (US); **David E. Yao**, San Francisco, CA (US); **Leonard John Duran**, San Francisco, CA (US)

(Continued)

(73) Assignee: **KENU, INC.**, San Francisco, CA (US)

(**) Term: **15 Years**

(21) Appl. No.: **29/533,278**

(22) Filed: **Jul. 15, 2015**

OTHER PUBLICATIONS

Kenu, Inc.; Stance Compact Tripod; <https://web.archive.org/web/20150202091854/http://www.kenu.com/products/STANCE/>; Archived date: Feb. 2, 2015.

Primary Examiner — Susan Bennett Hattan

Assistant Examiner — Leanne Was-Englehart

(74) *Attorney, Agent, or Firm* — Vierra Magen Marcus LLP

(57) **CLAIM**

We claim the ornamental design for a tripod for an electronic device, as shown and described.

DESCRIPTION

FIG. 1 is a front elevational view of a first embodiment of a tripod for an electronic device; FIG. 2 is a rear elevational view thereof; FIG. 3 is a right side elevational view thereof; FIG. 4 is a left side elevational view thereof; FIG. 5 is a top plan view thereof; and FIG. 6 is a bottom plan view thereof; FIG. 7 is a top plan view of the tripod for an electronic device in a deployed state; FIG. 8 is a bottom plan view thereof; FIG. 9 is a rear elevational view thereof; FIG. 10 is a front elevational view thereof; FIG. 11 is a right side elevational view thereof; FIG. 12 is a left side elevational view thereof; and, FIG. 13 is a perspective view thereof.

The broken lines are for illustrating unclaimed portions of the tripod for an electronic device; the broken lines form no part of the claimed design.

1 Claim, 12 Drawing Sheets

Related U.S. Application Data

(62) Division of application No. 29/506,667, filed on Oct. 17, 2014, now Pat. No. Des. 741,397.

(51) **LOC (10) Cl.** **16-05**

(52) **U.S. Cl.** **D16/242**

(58) **Field of Classification Search**

USPC D14/253, 447; D16/237, 242, 243, 244, D16/245; 224/908; 248/163.1, 166-171, 248/177.1, 178.1, 181.1, 185.1, 187.1, 248/434, 435, 440, 440.1; 396/419-428
CPC F16M 11/14; F16M 11/20; F16M 11/38; F16M 13/00; G03B 17/561

See application file for complete search history.

(56) **References Cited**

U.S. PATENT DOCUMENTS

4,640,482 A 2/1987 Rogers
4,648,698 A 3/1987 Iwasaki
4,751,540 A 6/1988 Jones
D299,243 S 1/1989 Iwasaki

(Continued)

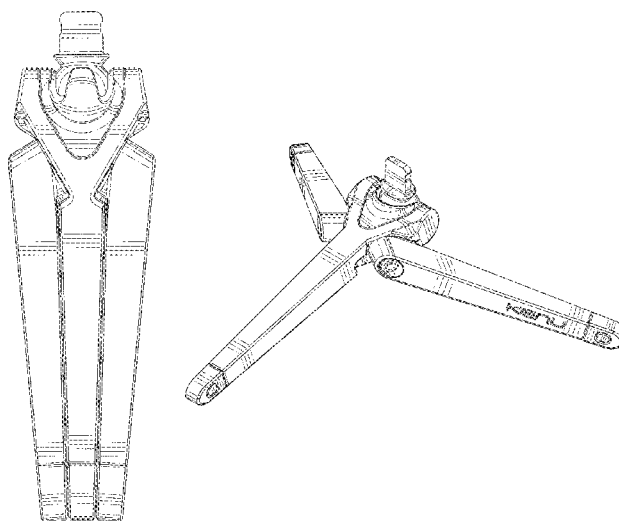

(56)

References Cited

U.S. PATENT DOCUMENTS

D349,717 S 8/1994 Akaike et al.
 D349,914 S * 8/1994 Usui D16/244
 D350,970 S * 9/1994 Usui D16/244
 5,390,885 A 2/1995 Shen
 D357,267 S * 4/1995 Yotsuya D16/244
 D357,493 S * 4/1995 Yotsuya D16/244
 5,708,890 A * 1/1998 Nakano F16M 11/20
 248/166
 5,772,164 A 6/1998 Shen
 D445,123 S * 7/2001 Shen D16/244
 6,579,017 B2 * 6/2003 Wei G03B 17/00
 248/168
 D508,938 S 8/2005 Murray et al.
 7,011,280 B2 3/2006 Murray et al.
 D532,436 S 11/2006 Kruse et al.
 7,290,740 B2 11/2007 Joy et al.
 D575,293 S 8/2008 Derry et al.
 D614,613 S 4/2010 Kim et al.
 7,712,719 B2 5/2010 Derry et al.
 8,186,639 B2 5/2012 Wang
 D664,182 S * 7/2012 Braunstein D16/242
 D669,065 S 10/2012 Fromm
 D690,707 S 10/2013 Minn et al.

D706,333 S * 6/2014 Chun D16/244
 D715,790 S 10/2014 Conomos et al.
 D717,360 S 11/2014 Chun
 D718,298 S 11/2014 Aspinall et al.
 D718,365 S 11/2014 Kim et al.
 D720,759 S 1/2015 Deng et al.
 D723,091 S * 2/2015 Hale D16/244
 D726,175 S 4/2015 Tsai et al.
 D741,397 S * 10/2015 Minn D16/244
 9,389,490 B2 * 7/2016 Esarey F16M 11/14
 2012/0269503 A1 * 10/2012 Hale F16M 11/14
 396/428
 2013/0175413 A1 7/2013 Waugh
 2014/0097306 A1 4/2014 Hale et al.

FOREIGN PATENT DOCUMENTS

CN 202749876 2/2013
 EM 002155614-0001 3/2013
 EM 002588962-0001 4/2015
 EM 002645523-0001 4/2015
 GB 2467614 A 8/2010
 JP D1250886 S 9/2005
 TW 455327 9/2001

* cited by examiner

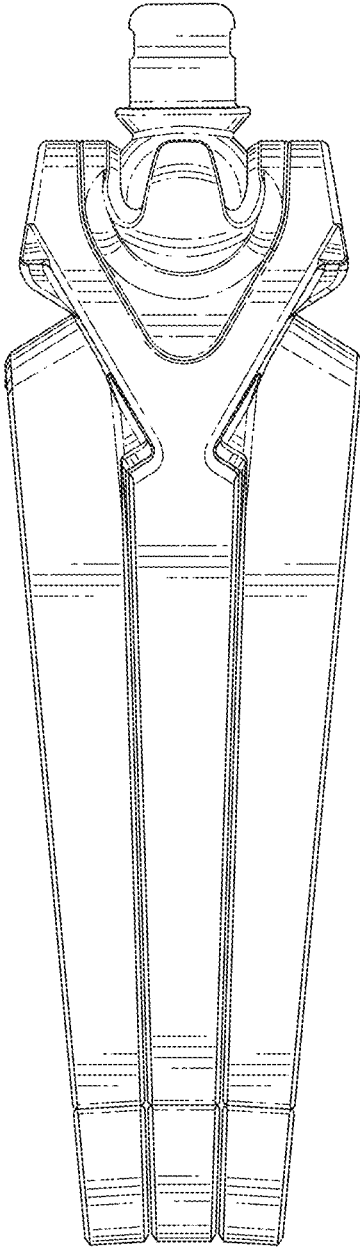

FIG. 1

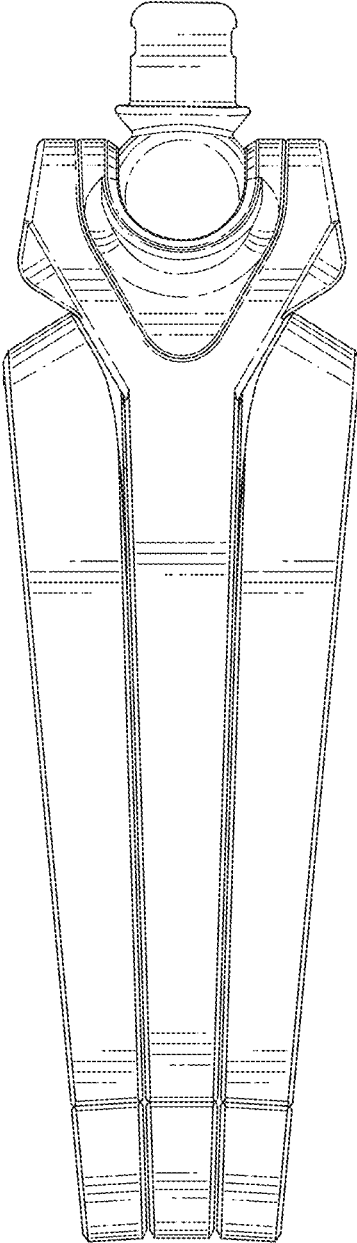

FIG. 2

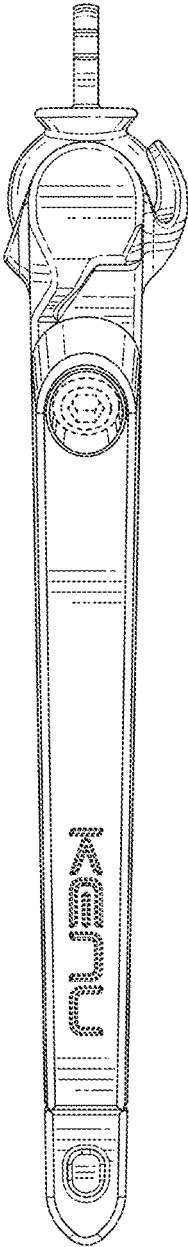

FIG. 3

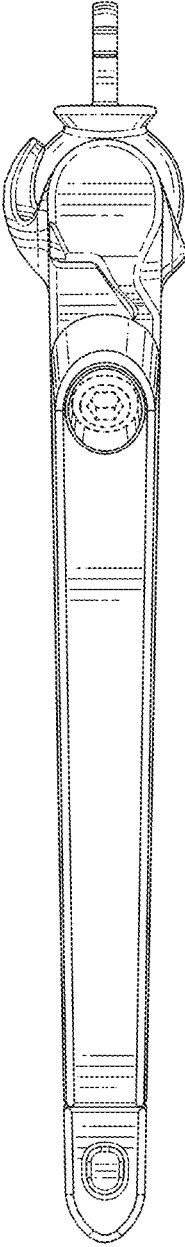

FIG. 4

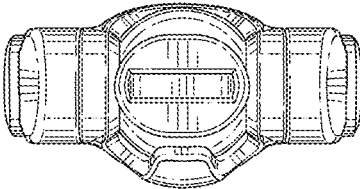

FIG. 5

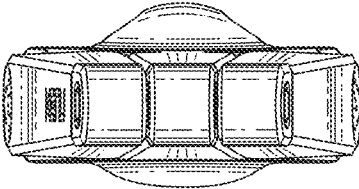

FIG. 6

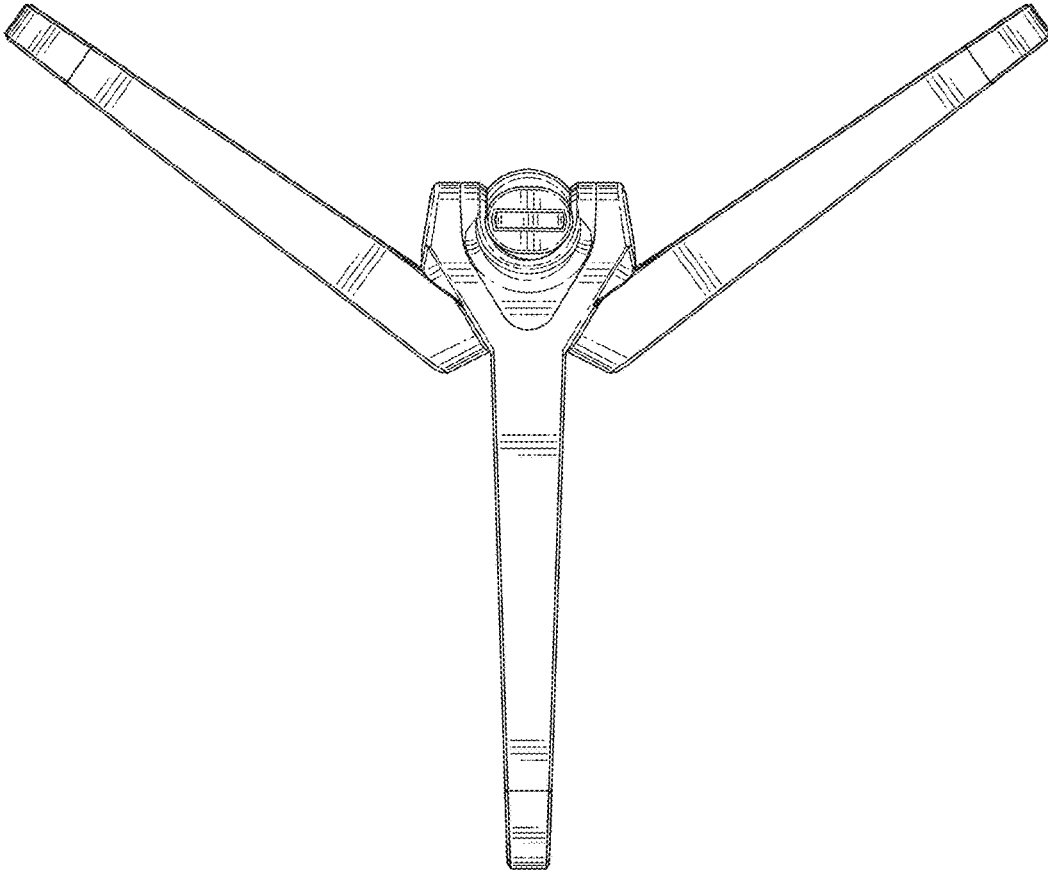

FIG. 7

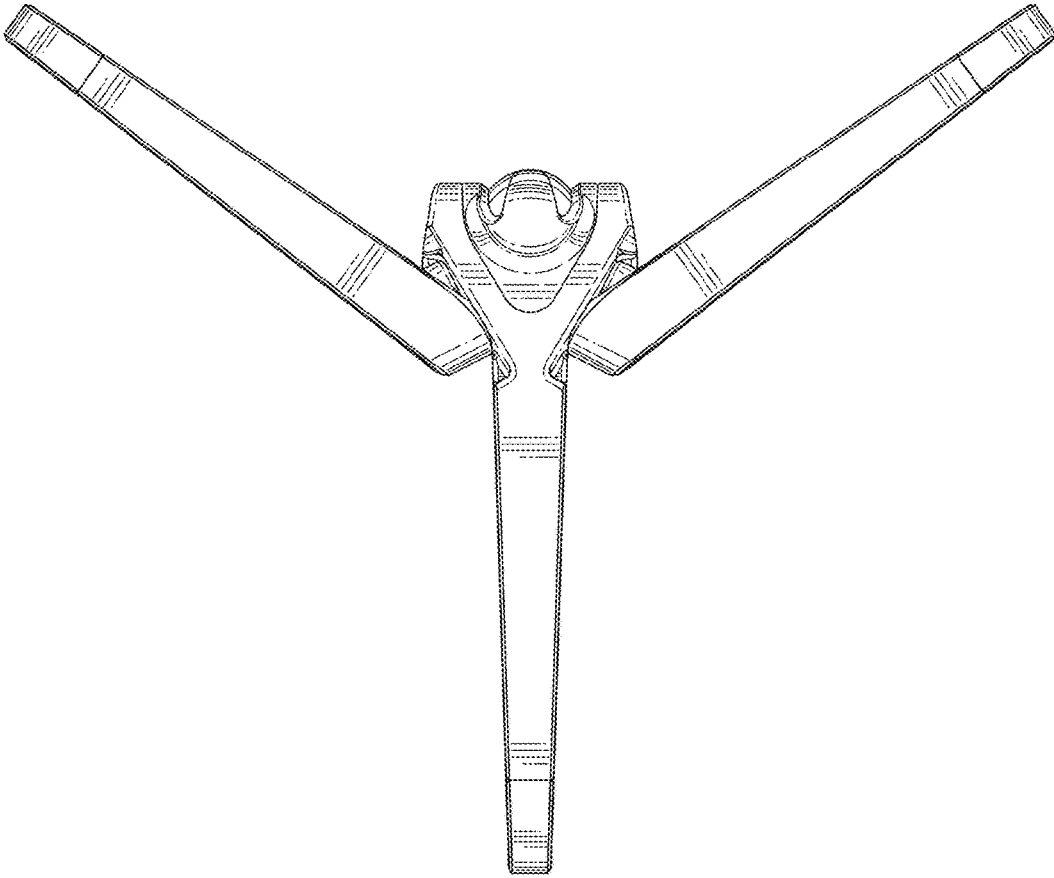

FIG. 8

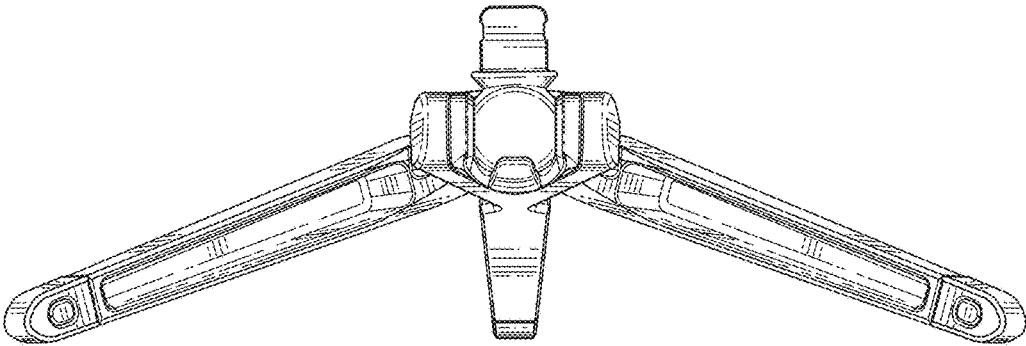

FIG. 9

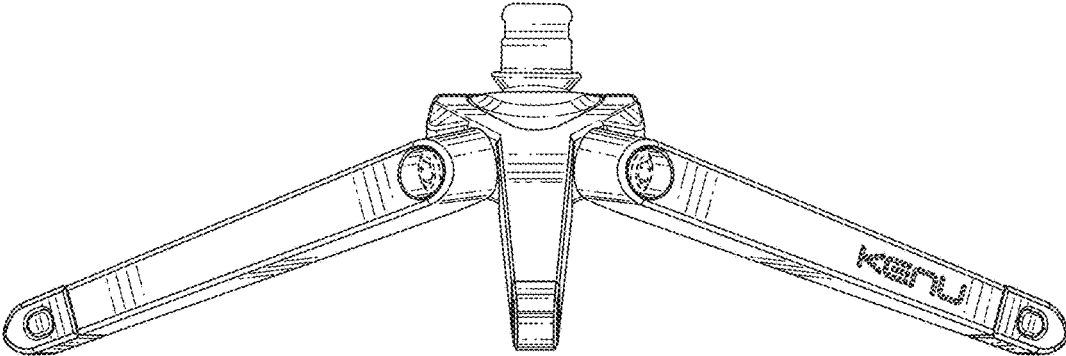

FIG. 10

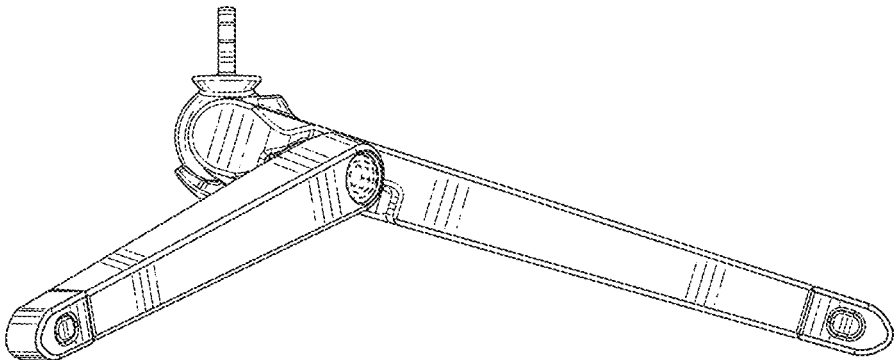

FIG. 11

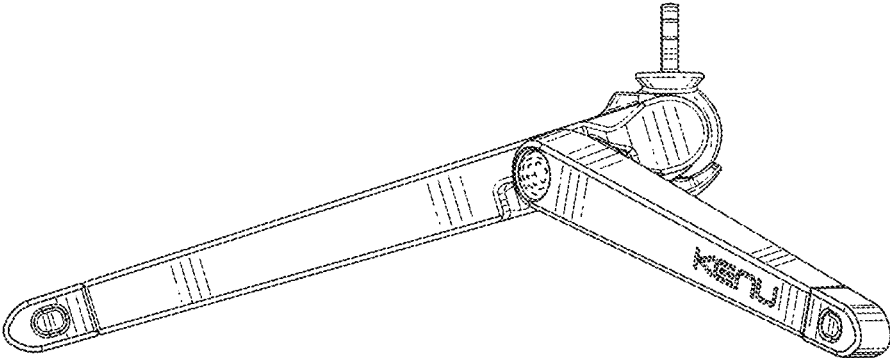

FIG. 12

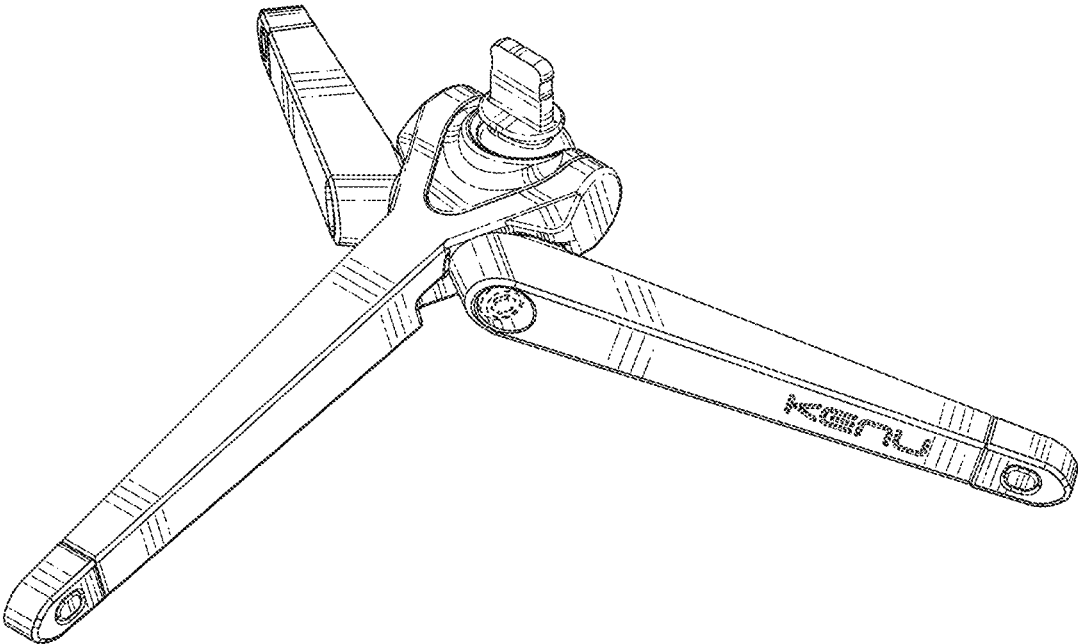

FIG. 13