

Aug. 1, 1933.

N. A. PINSON

1,920,522

DOUBLE WIRE AND CABLE GRIPPING DEVICE

Filed Nov. 7, 1932

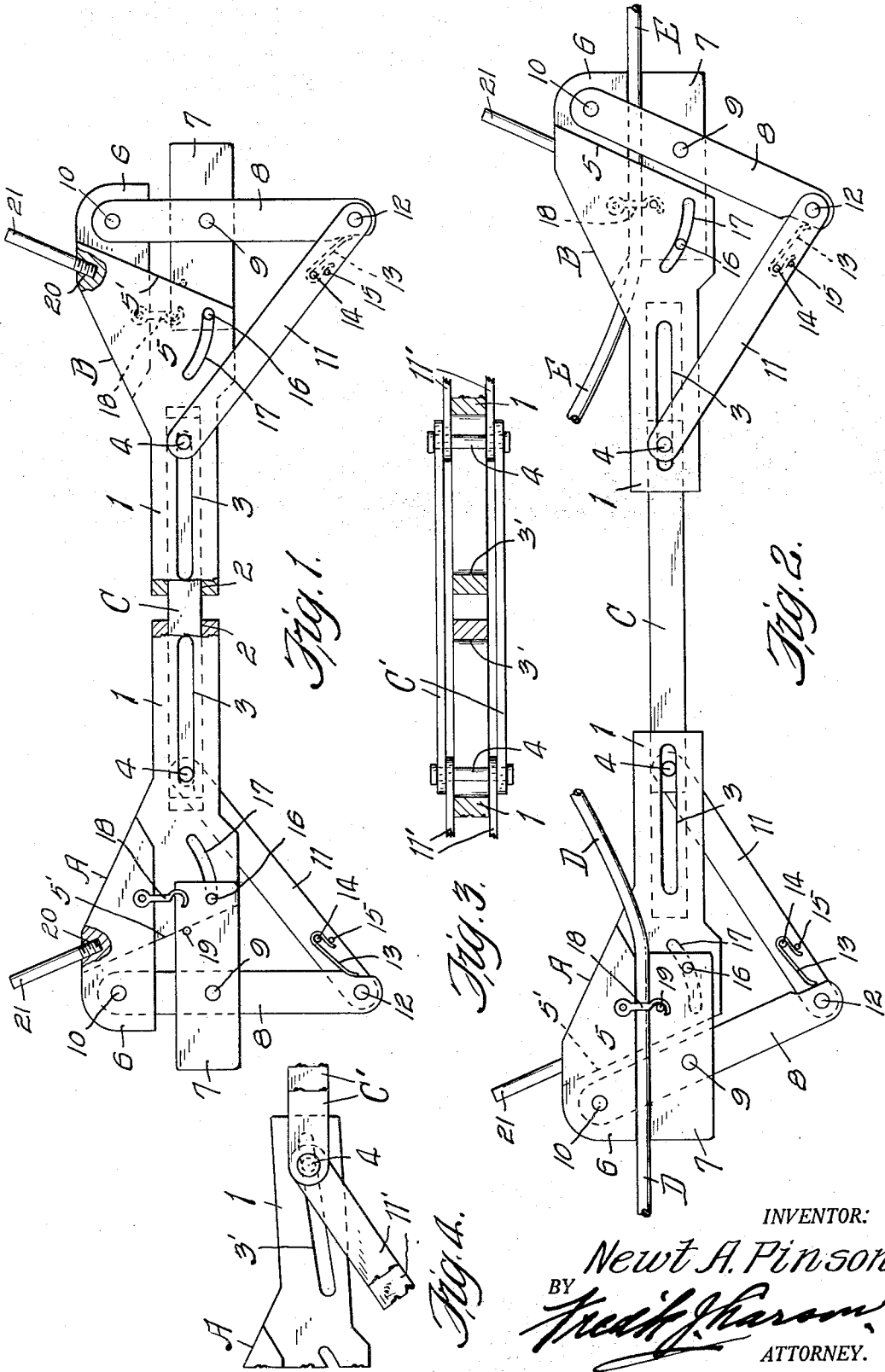

INVENTOR:

Newt A. Pinson.
BY *Frank J. Haron*
ATTORNEY.

UNITED STATES PATENT OFFICE

1,920,522

DOUBLE WIRE AND CABLE GRIPPING DEVICE

Newt A. Pinson, Jefferson, Ga.

Application November 7, 1932. Serial No. 641,586

5 Claims. (Cl. 24—134)

This invention relates to a double wire or cable grip.

The object of my invention is to provide a grip, or clamping device, which will grip a wire, or cable at two points along its length, or grip two separate wires or cables that are to be spliced.

A further object of the invention is the provision of a double wire, or cable grip, which can be readily attached to a wire, or wires and readily removed therefrom.

A still further object of the invention is the provision of a double wire or cable grip which possesses advantages in points of simplicity and efficiency, and, at the same time proves itself comparatively inexpensive in cost of manufacture.

With the above and other objects in view, the invention consists in the novel features of construction, arrangement and combination of parts hereinafter more fully described and finally pointed out in the claims hereto appended.

Referring to the accompanying drawing forming a part of this specification, wherein like characters of reference denote similar parts throughout the several views:

Fig. 1 is a side elevation of a double wire or cable grip embodying the features of my invention, and shown with the clamping jaws as open.

Fig. 2 is a side elevation of the device showing the two sets of clamping jaws as closed and gripping a wire or cable.

Fig. 3 is a detail showing a modification of the means for connecting the clamping jaw members.

Fig. 4 is a detail showing a portion of the modified connecting means and a portion of one of the clamping jaw members.

In carrying out the aim of my present invention, I employ two gripping devices which are interconnected and which are designated generally as A and B. The two devices are connected by means of a bar, or rod C, as clearly shown in the drawing.

Each gripping or clamping device comprises a suitable shank 1 having a longitudinal opening or passage 2 for receiving the ends of the connecting rod C. Each shank 1 is provided with opposed slots 3 for receiving the ends of pins 4, which pass through the ends of the connecting rod C. This arrangement limits the sliding movement of the shanks 1 upon the connecting rod, the purpose of which will be apparent hereinafter.

The outer end of each shank 1 is enlarged to provide a head 5 having its end face inclined, as at 5'. The head 5 of each device is provided

with a suitable laterally directed elongated stationary gripping jaw 6 which projects beyond the inclined end face 5' of each head 5.

Associated with each stationary wire or cable gripping jaw 6, is a suitable movable gripping jaw 7. The movable gripping jaws 7 are disposed below the stationary gripping jaws 6, as clearly shown in the drawing.

Each movable gripping jaw 7 is pivotally connected to a suitable lever 8, as at 9, intermediate the ends of the jaw. The upper end of each lever 8 is pivotally connected, as at 10, to one of the side faces of each projecting end of the stationary jaws 6.

A suitable lever 11 is pivotally connected, as at 12, to the lower end of each lever 8 and the upper ends of these levers 12 are connected to their respective pins 4 which pass through the ends of the connecting rod C and the slots 3 in the side walls of the two shanks, each designated 1.

Each lever 11 is provided with a suitable spring 13 which is held in position by means of the pins 14 and 15. One end of the spring 13 associated with each lever 11 bears and exerts pressure against the lower end of each lever 8.

Each movable gripping or clamping jaw 7 is provided, near its rear edge, with a laterally directed guide pin 16 which enters a curved slot 17 in the head 5 of each gripping device. This arrangement provides a guide for each movable gripping jaw 7 so that during its opening and closing movements, it will move in parallel relation with the stationary gripping jaws 6, by preventing rocking movement of movable jaws 7.

A suitable hook 18 is pivotally connected to each stationary jaw 6 adapted for engagement with a suitable pin 19 carried on each movable gripping jaw 7. This arrangement prevents a wire from moving laterally from between the gripping jaws when there is a side pulling strain thereon.

Each head 5 of the device is provided with a screw threaded opening 20 to receive a removable screw threaded handle bar 21 that can be grasped when the device is taken off of a cable that has a heavy strain on it.

From the foregoing description of the construction of the double wire or cable gripping, or clamping device, it is apparent that the device grips a cable at each end of the device, thus permitting two wires, designated D and E to be held by the device for any purpose. It will be apparent from Fig. 2, that where it is desired to splice the ends of the two wires D and E that it can be

readily accomplished, as the wires are firmly held by each end of the device. It is clearly apparent, also, that a wire can be gripped by one of the two sets of clamping jaws, looped around a post and the free end thereof clamped between the other set of clamping jaws.

In operation, to open the gripping jaws at either end of the device, the shanks 1 are moved toward each other on the connecting rod C, as shown in Fig. 1. In this position, it will be observed, the levers 8 are disposed in substantially vertical positions which lowers the jaws 7 relative to the jaws 6 so as to provide a gap F between the two sets of gripping jaws to receive the wire or wires, as the case may be.

To clamp each set of jaws against the wire, or wires, the operator moves the two shanks in directions away from each other to the position shown in Fig. 2, which movement of the shanks on the connecting rod from their positions in Fig. 1, causes the levers 8 to be moved into inclined positions and during their movement raise the movable clamping jaws 7 up toward the stationary clamping jaws 6 for gripping the wire, or wires between the two sets of gripping jaws at either end of the device. To release the jaws from gripping contact with a wire, or wires, the shanks 1 are moved toward each other on the connecting rod C.

In Figs. 3 and 4, I have shown the use of two connecting rods designated C', in lieu of the single connecting rod C shown in Figs. 1 and 2. In the modifications, the connecting rods are disposed to the sides of the slotted shanks 1 and the slots designated 3' are disposed on an incline instead of parallel with the walls of the shanks, as shown in Figs. 1 and 2. In the modifications, I have also shown the use of two levers designated 11' instead of the single lever designated 11 in Figs. 1 and 2.

The many advantages of the herein described invention will readily suggest themselves to those skilled in the art to which it appertains.

From the foregoing description, it is evident that a simple device for this purpose has been disclosed, but it is to be understood that I do not desire to restrict, or limit myself to the very details of the construction shown and described, which is merely illustrative, it being obvious that changes, not involving the exercise of invention, may be made without conflicting or departing from the spirit of the invention within the scope of the appended claims.

What I claim is:

1. A cable grip comprising two tubular shanks, a bar connecting said shanks and upon which the shanks are movable toward and away from each other, a stationary jaw on each shank, a movable jaw associated with and below each sta-

tionary jaw, a lever pivoted to each stationary jaw, said levers being also pivoted to the movable jaws and means for guiding the movement of the movable jaws toward and away from the stationary jaws in parallel relation thereto.

2. A device of the class described comprising two sets of clamping jaws, one jaw of each set being stationary and the other jaw of each set being movable relative thereto and parallel therewith, a tubular shank extending from the stationary jaw of each set of jaws, said shanks being slidably mounted upon a connecting rod, a lever pivotally connected at one end to each stationary jaw, a lever pivotally connected at one end to the other end of said first levers and pivotally connected at their opposite ends to the ends of said connecting rod, said movable jaws being pivotally connected to said first mentioned levers and means for guiding the inner ends of the movable jaws during movement of the levers which effects movement of the movable jaws.

3. In a device of the class described, a bar, a pair of shanks slidably mounted on said bar, a stationary clamping jaw extending from the outer end of each shank, a movable clamping jaw associated with each stationary clamping jaw and disposed therebelow, a pivoted lever connection between each stationary jaw and opposite ends of said bar whereby upon movement of said shanks on said bar movement is imparted to the movable clamping jaws and means for guiding the movement of said movable clamping jaws relative to the stationary clamping jaws.

4. In a device of the class described, a bar, a pair of spaced upper clamping jaws longitudinally slidable toward and away from each other on said bar, a lower clamping jaw associated with each upper clamping jaw, means connecting each upper clamping jaw with its respective end of said bar, means for moving the lower jaws relative to the upper jaws upon sliding movement of the upper jaws on said bar and means for guiding the movement of said lower jaws in parallelism with the upper jaws.

5. In a device of the class described, a bar, a pair of spaced upper clamping jaws longitudinally slidable toward and away from each other on said bar, a lower clamping jaw associated with each upper clamping jaw, means connecting each upper clamping jaw with its respective end of said bar, means for moving the lower jaws relative to the upper jaws upon sliding movement of the upper jaws on said bar, means for guiding the movement of said lower jaws in parallelism with the upper jaws, resilient means affording pressure to said lower jaws and a hook carried on each upper jaw having connection with means carried on the lower jaws.

NEWT A. PINSON.

65

140

70

145

75

150