

(No Model.)

2 Sheets—Sheet 1.

J. B. McLANE.  
METAL PUNCHING MACHINE.

No. 524,691.

Patented Aug. 14, 1894.

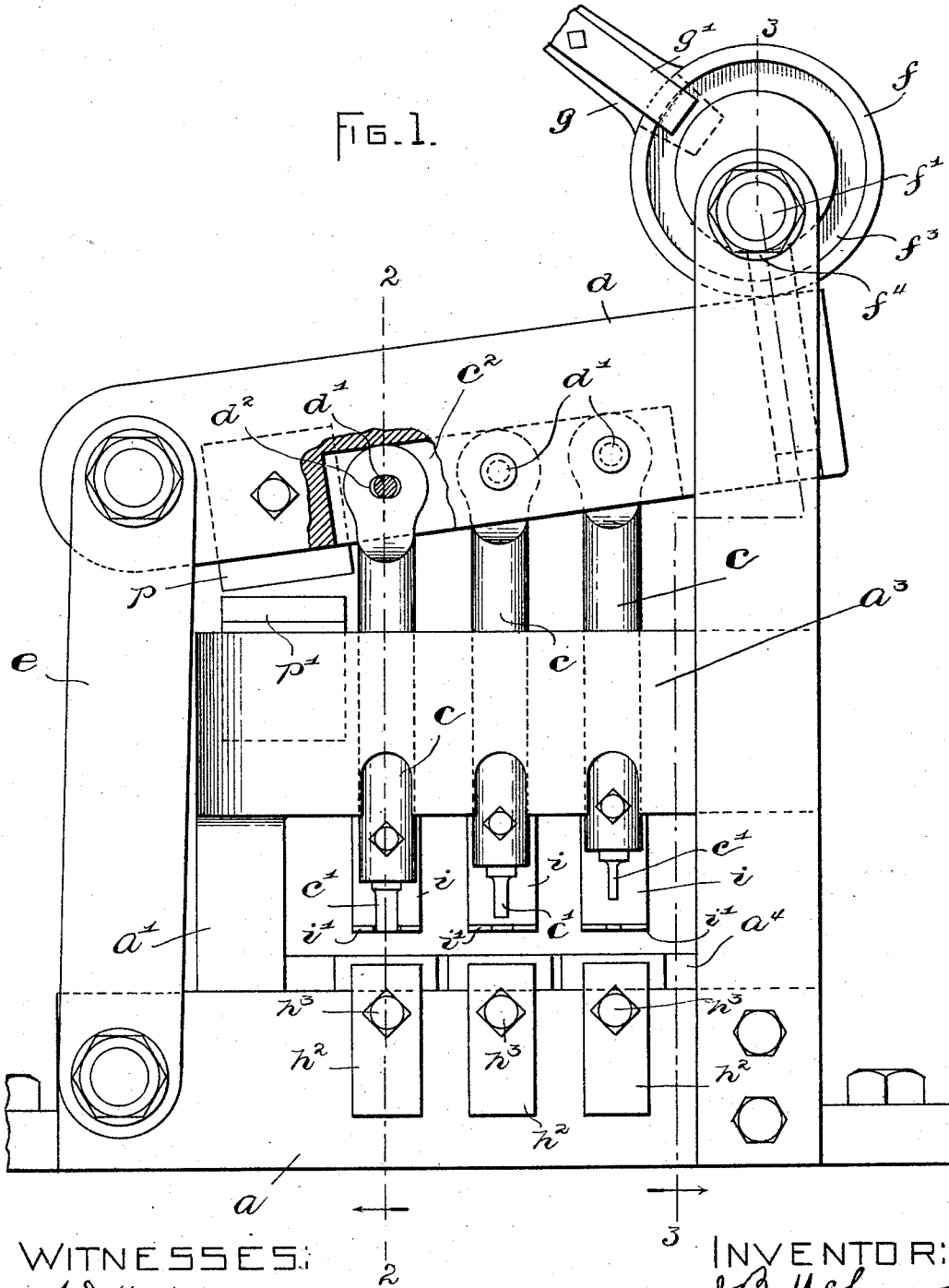

WITNESSES:

*A. D. Harrison.*  
*B. Davis.*

INVENTOR:

*J. B. McLane*  
*by Knight Brown & Dunby*  
*Atty.*

(No Model.)

2 Sheets—Sheet 2.

J. B. McLANE.  
METAL PUNCHING MACHINE.

No. 524,691.

Patented Aug. 14, 1894.

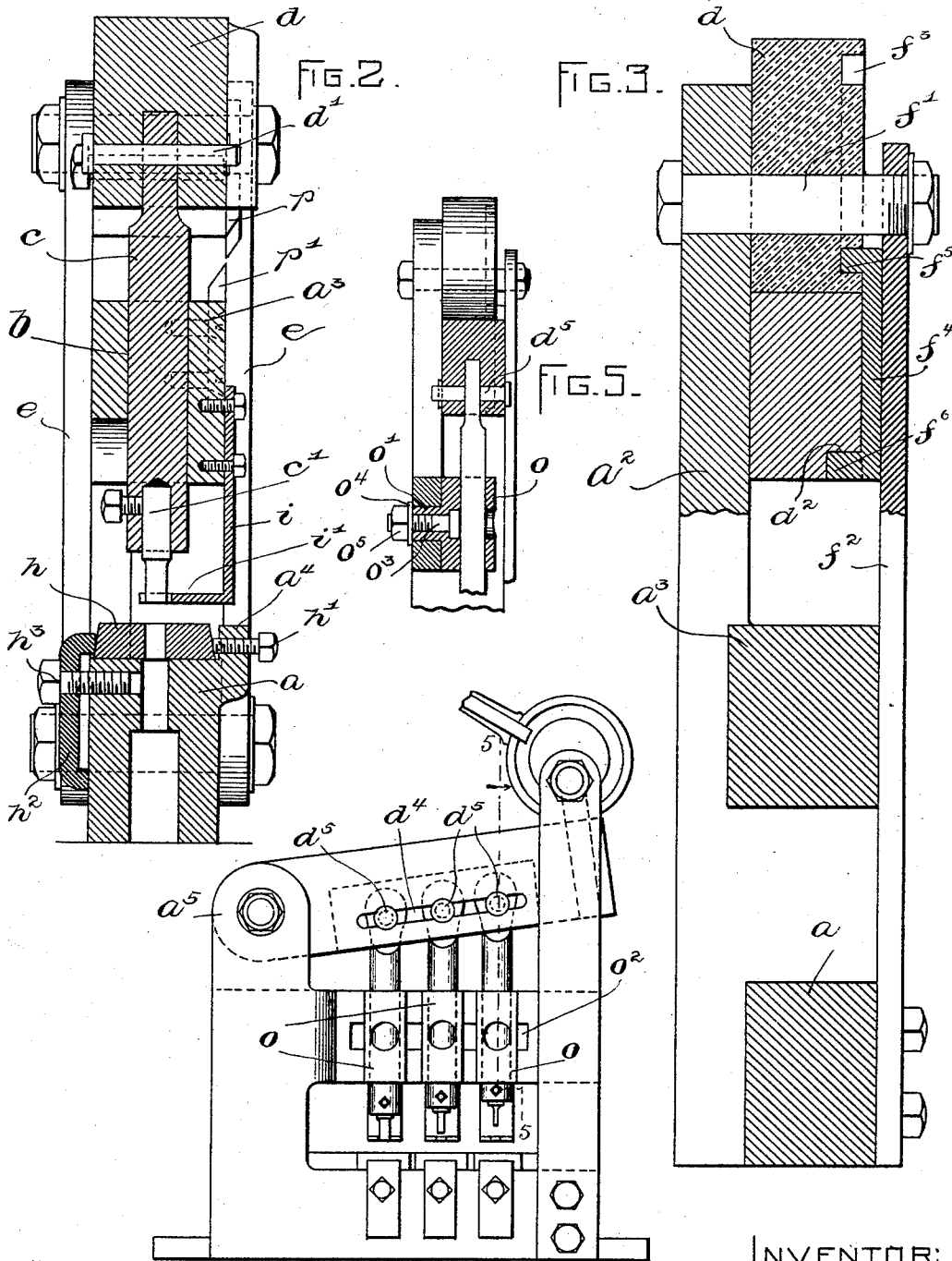

WITNESSES:  
*A. D. Harrison*  
*P. Davis.*

FIG. 4.

INVENTOR:  
*J. B. McLane*  
*by Wright, Brown & Dunby*  
*Atty.*

# UNITED STATES PATENT OFFICE.

JARED B. McLANE, OF NORTH READING, MASSACHUSETTS.

## METAL-PUNCHING MACHINE.

SPECIFICATION forming part of Letters Patent No. 524,691, dated August 14, 1894.

Application filed June 11, 1894. Serial No. 514,177. (No model.)

*To all whom it may concern:*

Be it known that I, JARED B. McLANE, of North Reading, in the county of Middlesex and State of Massachusetts, have invented certain new and useful Improvements in Metal-Punching Machines, of which the following is a specification.

This invention relates to a machine for punching sheet-metal and particularly designed for blacksmiths' use.

The principal objects in view are to secure a powerful machine, to provide for punching one or more holes by one operation, and to provide for adjustment of each punch of a gang employed so as to adapt the machine for a special work.

To the above ends the invention consists in certain novel features of construction and combinations of parts recited in the appended claims.

The accompanying drawings, which form part of this specification, illustrate embodiments of the invention.

Figure 1 shows a side elevation of a machine embodying the invention, a portion of a certain lever being broken out to disclose hidden parts. Fig. 2 shows a section on line 2—2 of Fig. 1. Fig. 3 shows a section on line 3—3 of Fig. 1. Fig. 4 shows a modified form of machine in side elevation. Fig. 5 shows a section on line 5—5 of Fig. 4.

The supporting frame of the machine as shown in Figs. 1 to 3 comprises a base,  $a$ , two uprights,  $a'$  and  $a''$ , rising therefrom and a horizontal bar,  $a^3$ , extending between the said uprights at a suitable distance above the base. Said horizontal bar is provided with a number of vertical bores,  $b$ , which constitute slide-ways for plungers,  $c$ , carrying the punches,  $c'$ . Three plungers are here shown but the number may be more or less according to requirements. The upper ends of the plungers are flattened and are received in a channel,  $c^2$ , formed in a lever,  $d$ , the base of the channel arranged to bear on the upper ends of the plunger so that upon depressing the lever the plungers will be lowered. The plungers are pivotally connected with the lever by pins,  $d'$ , passed through the latter and the plungers, and the upper ends of the latter are rounded so that the lever can rock thereon to the extent required by its arc

movement. Provision may be made in different ways for taking up the arc movement of the lever to prevent any binding of the plungers in their slide-ways. For example, the lever may be pivoted to a movable support, as the links or radius bars,  $e$ , shown in Figs. 1 and 2, said links being pivoted to the base,  $a$ , and free to swing sufficiently to permit free rectilinear movement of the plungers. Another way of accomplishing the same result is by slotting the plungers where the pins,  $d'$ , engage them, as shown at  $d^2$ . In this case the radius bars can be dispensed with and the lever pivoted to a stationary support, as in the form of machine shown in Fig. 4.

The lever,  $d$ , is depressed by a cam-disk,  $f$ , of circular form, journaled eccentrically on a bolt,  $f'$ , which is supported between the upright,  $a^2$ , of the supporting frame, and an auxiliary standard,  $f^2$ . The cam-disk is formed in one side with an annular groove,  $f^3$ , concentric with its periphery and the outer side of said groove forms a shoulder for lifting the lever, a hook or link,  $f^4$ , forming the connection by engagement of a lug,  $f^5$ , on its upper end with the annular groove in the cam-disk and engagement of a lug,  $f^6$ , on its lower end with an offset,  $d^3$ , in the lever. It will be understood that the lifting of the lever through the means just described, raises the plungers through the medium of the pins,  $d'$ . The cam may be operated by hand or by power and is here shown arranged to be operated by hand through the medium of a detachable lever,  $g$ . The latter has one end constructed for insertion in a socket formed radially in the disk, and a spring latch,  $g'$ , is fastened to the lever and adapted to take over the flange formed by the groove,  $f^3$ , and hold the lever in place.

It will be seen that the devices described provide very powerful means for depressing the punches. A die-bed,  $h$ , is mounted on the base,  $a$ , below each plunger and each die-bed is adjustable so as to accommodate different punches which may be fitted to the plunger.

The base,  $a$ , is formed with an upstanding back-flange,  $a^4$ , and set-screws,  $h'$ , are entered through said flange so as to bear against the rear-sides of the dies. Flanged clamping plates,  $h^2$ , are fitted against the front side of the base,  $a$ , and bear against the front sides

of the dies, said plates being connected with the base by screws,  $h^3$ , passed through them and entering screw-threaded holes in the base.

5 Guards,  $i$ , are fastened to the bar,  $a^3$ , and depend therefrom, said guards having horizontally extending portions,  $i'$ , with bifurcated ends embracing the punches. These guards hold the work down and act to pull it off the punches when they rise.

10 It will now be seen that my invention provides means for punching a number of holes at one operation, and it is to be noted that the punches do not act simultaneously on the work but one after the other, which does not require so great expenditure of power.

15 Of course it is not necessary to use all the punches at once, but any one of them can be used independently and if the plungers of those not used are located so near the one in use as to encounter the work, these punches can be removed from their plungers.

20 A modified construction is illustrated in Figs. 4 and 5, in which provision is made for adjustment of the plungers as to their distance apart. The supporting frame and devices for operating the plungers are of substantially the same form and arrangement as previously explained. In this case, however, the lever is pivoted to a rigid arm,  $a^5$ , of the supporting frame, and is formed with a longitudinal slot,  $d^4$ , which receives the pivot pins,  $d^5$ , of the plungers, said slot being of sufficient extent to allow for lateral adjustment of the plungers and also for the arc movement of the lever. Each plunger fits through a separate guide,  $o$ , and these guides are adjustably supported on the horizontal bar of the supporting frame, the said guides each having a square shank,  $o'$ , engaging a slot,  $o^2$ , extending longitudinally of the bar. Bolts,  $o^3$ , entered through the guides and their shanks carry washers,  $o^4$ , extending over the supporting bar, and nuts,  $o^5$ , beyond said washers. By this means the guides may be clamped at different positions. A machine of this modified form is adapted for adjustment to special work and offers many advantages for this reason.

50 It is evident that the invention is not limited to the details of construction hereinbefore enumerated or illustrated in the drawings, and the structure here shown and de-

scribed may be variously modified within the scope of the invention.

In Figs. 1 and 2 I have shown shearing 55 blades,  $p$  and  $p'$ , affixed to the lever,  $d$ , and bar,  $a^3$ , respectively.

What I claim as my invention is as follows:

1. A metal-punching machine comprising in its construction, a base supporting one or 60 more dies, uprights at opposite ends of said base, a lever pivoted at one end to one of said uprights and extending alongside the other upright, a cam pivoted to said latter upright and coacting with the lever, one or more plungers connected with said lever, and a suitable 65 guide for the plungers.

2. A metal punching machine comprising in its construction, a base supporting one or more dies, an upright pivoted to one end of 70 said base, a rigid upright at the opposite end of the base, a lever pivoted at one end to the pivotal upright and its free end disposed alongside the rigid upright, a cam pivoted to the latter and coacting with the lever, one or 75 more plungers connected with the lever, and a suitable guide for the plungers.

3. A metal punching machine comprising in its construction, a base supporting one or more dies, uprights at opposite ends of said 80 base, a lever pivoted at one end to one of said uprights and extending alongside the other upright, a cam pivoted to said latter upright and designed to bear with its periphery upon the lever, said cam having a lifting shoulder, 85 a link having a lug at one end taking over the said shoulder, and a lug at the other end extending under a portion of the lever, one or more plungers connected with the lever, and a guide for said plungers. 90

4. In a metal punching machine, the combination of a lever, a gang of plungers independently and adjustably connected with said lever, and a separate guide for each plunger adjustable on a suitable support. 95

In testimony whereof I have signed my name to this specification, in the presence of two subscribing witnesses, this 7th day of June, A. D. 1894.

JARED B. MCLANE.

Witnesses:

C. F. BROWN,  
A. D. HARRISON.