

(19) World Intellectual Property
Organization
International Bureau



(43) International Publication Date
1 July 2004 (01.07.2004)

PCT

(10) International Publication Number
WO 2004/054424 A1

(51) International Patent Classification⁷: **A47L 13/146**

(21) International Application Number:
PCT/IT2002/000802

(22) International Filing Date:
18 December 2002 (18.12.2002)

(25) Filing Language: Italian

(26) Publication Language: English

(71) Applicant and

(72) Inventor: **NICCOLAI, Celestino** [IT/IT]; Via Giacomo
Matteotti, 94, I-51036 Larciano (IT).

(74) Agents: **MANNUCCI, Michele** et al.; Uff. Tecn. Ing. A.
Mannucci S.r.l., Via della Scala, 4, I-50123 Firenze (IT).

(81) Designated States (national): AE, AG, AL, AM, AT, AU,
AZ, BA, BB, BG, BR, BY, BZ, CA, CH, CN, CO, CR, CU,

CZ, DE, DK, DM, DZ, EC, EE, ES, FI, GB, GD, GE, GH,
GM, HR, HU, ID, IL, IN, IS, JP, KE, KG, KP, KR, KZ, LC,
LK, LR, LS, LT, LU, LV, MA, MD, MG, MK, MN, MW,
MX, MZ, NO, NZ, OM, PH, PL, PT, RO, RU, SC, SD, SE,
SG, SK, SL, TJ, TM, TN, TR, TT, TZ, UA, UG, US, UZ,
VC, VN, YU, ZA, ZM, ZW.

(84) Designated States (regional): ARIPO patent (GH, GM,
KE, LS, MW, MZ, SD, SL, SZ, TZ, UG, ZM, ZW),
Eurasian patent (AM, AZ, BY, KG, KZ, MD, RU, TJ, TM),
European patent (AT, BE, BG, CH, CY, CZ, DE, DK, EE,
ES, FI, FR, GB, GR, IE, IT, LU, MC, NL, PT, SE, SI, SK,
TR), OAPI patent (BF, BJ, CF, CG, CI, CM, GA, GN, GQ,
GW, ML, MR, NE, SN, TD, TG).

Published:
— with international search report

For two-letter codes and other abbreviations, refer to the "Guidance Notes on Codes and Abbreviations" appearing at the beginning of each regular issue of the PCT Gazette.

(54) Title: DOMESTIC CLEANING DEVICE WITH PIVOTING SQUEEZING PLATES

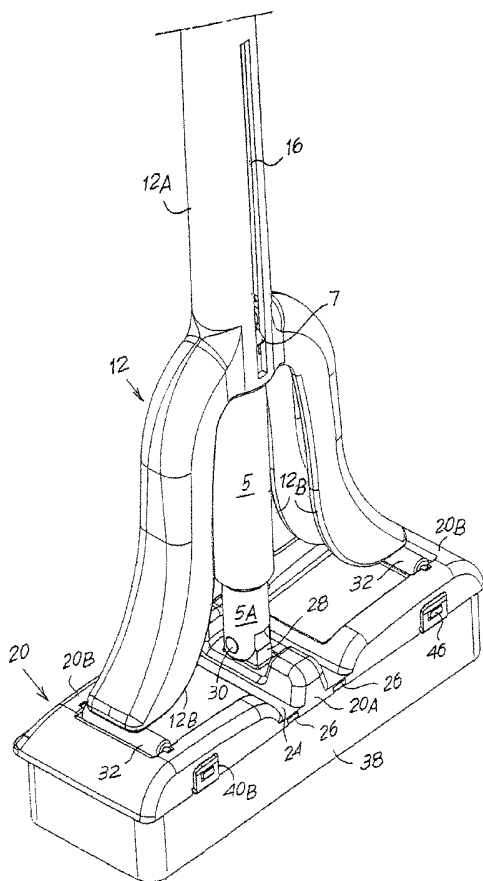

(57) Abstract: The staff (1) is joined to the central element (20A) of a base (20) which comprises two lateral portions (20B) joined elastically by thin portions (24) and by the co-molding of rubber layers (26) to the central element (20A); a fork member (12) with a tubular extension (12A) is slidable along the staff (1) and has S-shaped inner profiles (12B) to allow contact via rollers (32) with the lateral portions (20B) of said base (20); a replaceable assembly consisting of a sponge layer (38) bonded to rigid flat elements can be detached to the base (20) and released therefrom. The staff (1) is detachable. (Fig.1)

WO 2004/054424 A1

DOMESTIC CLEANING DEVICE WITH PIVOTING SQUEEZING PLATES

DESCRIPTION

The invention relates to a domestic cleaning device, which is improved
- with respect to similar devices already in use - by its structural simplicity, low
5 production cost, and ease of assembly, even in a domestic setting; to this may
be added the ease of handling in respect of the operations of squeezing the
sponge layer which forms the cleaning element and reconfiguring for use.

These and other objects and advantages will be made clear by the
following text.

10 Essentially, the domestic cleaning device according to the invention
comprises a combination of:

- a staff-type structure;
- a base with a central element joined to said staff-type structure and
two lateral portions joined elastically to said central element by co-molding of
15 layers of rubber;

- a fork member with a tubular extension which can be slid along said
staff with the aid of a grip, said fork member having inner profiles for contact
with the lateral portions of said base;

- a replaceable assembly consisting of a layer of sponge bonded to
20 rigid flat elements provided with means for interacting with means on the base
for attaching said assembly to said base and for releasing it therefrom.

The sliding of said fork member with respect to said staff-type structure
causes said base to flex, against the elastic force which tends to spread it out,
and consequently causes the flexing and squeezing of the sponge layer.

25 The base is advantageously co-molded with the two lateral portions, by
using flexible thin layers, and with co-molded rubber layers to form the joints
between said central element and said two lateral portions. The synthetic
resin components of the base can be connected with thin layers at the
positions of said joints. This prevents the wear of the joints which are made
30 partially from thin layers of synthetic resin (such as propylene), and provides
an elastic force tending to return the cleaning assembly to the spread-out
configuration, without the use of mechanical members but solely as a result of

- 2 -

the presence of the co-molded rubber layers. Thus a thin, non-wearing joint, made from synthetic resin (such as polypropylene), is produced; the joint acts elastically on the lateral portions so that they tend to spread out into the coplanar configuration, without the use of mechanical springs.

5 In an advantageous embodiment, each of the lateral portions of said base forms a seat for a roller, which can make rolling contact with the inner shaped profiles of the fork member. This facilitates the squeezing operation because of the "S" shape of said inner profiles and the presence of the rollers.

The device can comprise a means of limiting the longitudinal travel of
10 said fork member with respect to the staff. This can be provided in the form of a sleeve mounted onto and engaged with the lower end of the staff; said sleeve forms a seat for joining to said base and has an elastic catch which can engage slidably in a longitudinal slot of the tubular extension of the fork member, thereby limiting the longitudinal travel of said fork.

15 The staff (particularly a tubular staff) is made so that it can be coupled to the actual device by a simple operation, particularly by screwing, as a result of the presence of said sleeve, which forms a seat for the staff.

The aforesaid embodiment reduces the costs of storage and dispatch.

An assembly which can be replaced when it becomes worn can be
20 used with the device. This assembly comprises the sponge layer and the flat elements, which have strips on one side and have flexible fastenings on the other side, for interacting with slots and with appendages formed in the base; stop elements interacting with ribs in said base are also provided.

The invention will be more clearly understood from the description and
25 the attached drawing, which shows a practical and non-restrictive embodiment of said invention. In the drawing,

Figs. 1, 2 and 3 are perspective views of the device in the operating configuration, in an intermediate configuration and in the configuration in which squeezing has been carried out;

30 Figs. 4 and 5 show a longitudinal section and a partial enlargement of said section of the device in the operating configuration;

Figs. 6 and 7 are perspective views of a component of the device and

- 3 -

its combination with the components associated with the staff;

Figs. 8 and 9 are two perspective views of a base for the engagement of the replaceable assembly including the sponge layer;

Figs. 10, 11 and 12 are perspective views of said replaceable
5 assembly in isolation and in the stages of fitting on said base;

Fig. 13 is an exploded perspective view of the components of the device;

Fig. 14 is a perspective view of the base and of the replaceable
a assembly when it is about to be engaged with said base; and

10 Figs. 15 and 16 show the device on completion of the fitting of the replaceable assembly on the base, with the staff inclined with respect to the base.

In the attached drawing, the number 1 indicates a tubular staff for operating the device, said staff being provided at its lower end, for the fitting
15 of the actual device itself, with a terminal 3 provided with a threaded appendage 3A. The number 5 indicates a sleeve which can be threaded onto the lower end of the staff and engaged by screwing with the appendage 3A of the terminal 3, in such a way that it becomes stably engaged with the staff. The sleeve 5 has a catch 7 which is elastic and shaped with a taper, and an
20 opposing projection 7A for the purposes indicated below; additionally, a lower extension 5A of said sleeve 5 has a transverse hole 9 for joining the assembly which is to be used for cleaning and which must be inclinable with respect to the staff for the operations required during the use of the device.

On the lower part of the staff 1 provided with the sleeve 3 there is
25 threaded the tubular extension 12A of a fork member 12 in which the prongs of the fork are slightly S-shaped and have correspondingly shaped inner profiles 12B, for interaction with rolling members for the functions described below. The two prongs of the fork member 12 are hollow, to meet the requirements of molding and to provide lightness. The tubular
30 extension 12A of the fork is combined with a grip 14 which is snapped onto the end of said tubular extension 12A. The extension 12A has a long longitudinal slot 16, into which the catch 7 of the sleeve 5 can

- 4 -

snap; said extension 12A also has a longitudinal groove in which the projection 7A is slidably engaged. This arrangement enables the staff 1 and the fork member 12 to be kept coupled angularly together, and limits the axial movements which the grip 14 can impart to the fork member 12, 12A along the staff 1 provided with the sleeve 5; the angular orientation of the fork member 12 by the catch 7 and the projection 7A of the sleeve 5 enables this fork member 12 to be kept in the geometric plane passing through the axis of the transverse hole 9 of the sleeve 5 and through the axis of the staff 1.

The staff 1 can easily be engaged with the sleeve 5 by screwing; this helps to reduce the overall dimensions for storage and transport.

The number 20 indicates in a general way a base (see also Figs. 8, 9, and 11 to 16) which essentially consists of a central element 20A and two symmetrical lateral portions 20B, the whole being made by the method of molding with two components (co-molding); the base 20, 2A, 2B, 20B is concave below and convex above to provide lightness and rigidity in the lateral portions 20B and in the central element 20A. The co-molding forms an elastic joint between the central element 20A and each of the lateral portions 20B at the positions of thin transverse portions 24 which are supplemented with rubber layers 26 co-molded with the base 20. The presence of the rubber layers 26 along the areas 24, the lateral portions 20B are pushed so that they move away from each other and tend to enter a coplanar configuration as indicated in Figs. 8, 9, 11, 12 and 13, from a folded configuration as shown in Fig. 3. The portions 24 are too thin to impede the elastic effect of the rubber layers 26; these portions 24 withstand multiple bending without deterioration.

The central element 20A of the base 20 has a central eye 28 which can be housed in the end 5A of the sleeve 5 which is fork-shaped at 5C (see Fig. 6), in such a way that the hole of the eye 28 is aligned with the hole 9 of said fork-shaped part 5C of the extension 5A of the sleeve 7. A pin 30, inserted in the hole 9 and in the eye 28, joins the staff as follows in such a way that the staff can move angularly about the axis of the pin 30 in the plane of the axis of symmetry of said base 20.

The lateral portions 20B, which are symmetrical with respect to each

- 5 -

other, are shaped with limited and approximately flat depressions 20E which terminate externally in approximately semicylindrical recesses 20F (see Fig. 8) for housing rollers 32 (see Fig. 9) which can be snap-fitted into seats 20G formed at the ends of each of the recesses 20F; thus the rollers 32 can easily rotate about their axes. The rollers 32 are designed to interact with the double inner profiles 12B of the fork member 12 described above, for the purposes indicated below.

A replaceable assembly, indicated in a general way by 36 (see also Figs. 10 and 11) can be fitted under the base 20. Said replaceable assembly 36 comprises a sponge layer 38 which is designed to contact the surfaces to be cleaned with the device, or to contact cloths for cleaning a floor or the like; the sponge layer 38 is bonded to two rigid flat elements 40 which can be made from molded synthetic resin and which can be interconnected by links 42 which are made in a curved shape so that they are flexible. Each of the two rigid flat elements 40 has a pair of rigid front strips 40A on one side and a flexible catch appendage 40B, with an approximately rectangular aperture, on the other side; each rigid flat element 40 also has a pair of stops 40C in an intermediate position. In a corresponding way, each of the two lateral portions 20B of the base 20 has, on one side, a pair of apertures 44 for receiving the front strips 40A, and, on the other side, a projection 46 for engaging in the corresponding perforated flexible appendage 40B of the rigid flat elements 40. In the lower hollow part of the lateral portions 20B there are stiffening ribs 20K (see Fig. 14), one of which, for each of the portions 20B, can interact with the corresponding stop 40C. Thus the assembly 36 can be rapidly and stably attached to the base 20, and released therefrom, with the aid of the front strips 40A, the stops 40C and the perforated elastic appendages 40B. This enables worn assemblies 36 to be replaced easily with other new assemblies during the use of the device in the home.

The operation of the device will be described above in more detail in the following description. In order to use the device with the assembly 36 spread out as shown in Figs. 4, 5, 15 and 16, the user can maneuver the device with the sponge layer 38 for the cleaning operations, with the possibility of

- 6 -

inclining the staff with respect to the base as shown in Figs. 15 and 16.

When the sponge layer is filled with dirty water and has to be squeezed out, and when the device is to be put away without the base spread out, the grip 14 and the fork member 12 are slid along the staff 1 for the distance permitted by the slot 16 in which the catch 7 slides, and thus the two lateral portions 20B of the base 20 are made to bend around the elastic joints 24 and 26 from the outspread position of Figs. 1, 4 and 5 to an inclined position as shown in Fig. 2 and finally to the configuration of Fig. 3, in which the two lateral portions 20B are positioned so that they are parallel and brought together to a limited extent so that they enclose between them the double layer of the sponge which has been folded up and thus compressed to expel the water. The operation of returning the two lateral portions 20B to the configuration shown in Fig. 3 is carried out by sliding the fork member 12 along the staff 1 in the direction of the arrow f1 of Fig. 3, the rollers 32 rolling along the shaped inner profiles 12B of the fork member 12; this permits an extremely easy maneuver in the direction of the arrow f1. When the device is to be returned to the operating condition, it is simply necessary to slide the fork member 12 by means of the grip 14 along the staff 1 in the direction opposite the arrow f1, so that the base 20 is returned outside the prongs of the fork 12 and the rubber parts 26 of the elastic joints 24 and 26 return the lateral portions 20B of the base 20 to the planar or approximately planar configuration, to return the sponge 38 to the configuration for the cleaning operations.

In normal operation, the device is in the state shown in Figs. 1, 4 and others. The fork member 12 bears on the rollers 32 and the staff with the fork member gripped by the user can rotate about the pin 30 with respect to the base 20 through at least 45° from the vertical position with respect to the ground. The member 12 keeps the assembly 20, 38 in the planar configuration.

When the sponge layer 38 is to be squeezed, the procedure is as follows. The tube 1 is gripped with one hand while the other hand grips and makes the whole system 12, 14 slide downward along the tube 1. In

- 7 -

the first part of this travel, the ends of the fork 12 press on the base 20 by means of the contact of the rollers 32, and the lateral portions 12B of the base are forced to rotate about the joints 24 and 26 and to position themselves approximately orthogonally with respect to the tube. Continuing in their travel, the base 20 and the assembly 38, 40 remain at all times in contact with the fork member solely by means of the contact of the rollers 33 with the portions of the opposite edges 12B which have been brought together; the rollers 33 limit the friction and consequently the force required for the squeezing c

5 ation.

10 The base 12 and the sponge assembly 38, 40 are bent around the two hinges 24 and 26 which consist of the two co-molded rubber elements 26. The movement terminates when the base 12 and the assembly 38, 40 are fully bent (Fig. 3) and the base 20 bears on the central area of the fork member 12. In these conditions, the sponge is fully compressed and thus

15 squeezed. When the fork member assembly (12, 12A, 14) slides in the reverse direction, the lateral portions 20B of the base 20 tend to return to the extended configuration in which they are coplanar with the central element 20A; when the cleaning operations are resumed, the lateral portions move back to the extended configuration for contact with the floor, until they bear on

20 stops, about the pin 30. This all takes place as a result of the elastic reaction of the rubber parts 26.

Clearly, the drawing shows only an example provided solely as a practical demonstration of the invention, and this invention can be varied in its forms and arrangements without departure from the guiding principle of the invention. Any reference numbers present in the claims have the sole purpose

25 of facilitating the reading of the claims with reference to the description and to the drawing, and do not limit the scope of protection represented by the claims.

- 8 -

CLAIMS

1) Domestic cleaning device characterized in that it comprises a combination of: a staff-type structure (1, 5); a central element (20A), joined to the end of said staff-type structure (1, 5), of a base (20) which comprises two lateral portions (20B) which are co-molded with said central element (20A) and with layers of rubber (26) to provide elastic flexibility; a fork member (12) with a tubular extension (12A) which can be slid along said staff (1, 5) with the aid of a grip (14), said fork member (12) having inner profiles (12B) for contact with the lateral portions (20B) of said base (20); on said base (20), means for attaching and releasing a replaceable assembly (36); said replaceable assembly (36) consisting of a sponge layer (38) bonded to rigid flat elements (40) provided with means (40A, 40B, 40C) for interacting with means (44, 46) for attaching said assembly to said base (20) and releasing it therefrom; the sliding of said staff-type structure (1, 5) with respect to said fork member (12) causing said base (20) to flex, against the elastic force which tends to spread it out, and consequently causing the flexing and squeezing of the sponge layer (38).

2) Device according to Claim 1, characterized in that said base (20) is made by molding with co-molded rubber layers (26) to form elastic joints between said central element (20A) and said two lateral portions (20B), the components (20A, 20B) of the synthetic resin base (20) being connected with thin layers (24) at the positions of said joints.

3) Device according to Claim 1 or 2, characterized in that each of the lateral portions (20B) of said base (20) forms a seat (20F) for a roller (32), which can make rolling contact with the corresponding inner shaped profile (12B) of the fork member (12), to facilitate the squeezing operation by their contact with said S-shaped inner profiles (12B).

4) Device according to Claim 1 at least, characterized in that it comprises a means of limiting the longitudinal movement of the fork member (12) with respect to the staff.

5) Device according to Claim 4 at least, characterized in that it comprises a sleeve (5, 5A) which can be mounted onto and engaged with the

- 9 -

lower end of the staff (1), said sleeve forming a seat (9) for joining to said base (20) and having an elastic catch (7) which can engage slidably in a longitudinal slot (16) of the tubular extension (12A) of the fork member (12), thereby limiting the longitudinal travel of said fork.

5 6) Device according to Claim 5, characterized in that it comprises a screw connection between the end (3A) of the staff (1) and the end (5A) of said sleeve (5, 5A) and an angular fastening (7, 7A) for the operations of connecting the staff to the assembly (12, 20) of the device and releasing it
t efrom.

10 7) Device according to at least any one of the preceding claims, characterized in that it comprises, as a replaceable component, the assembly (36) with the sponge layer (38) and the flat elements (40), these elements (40) forming, on one side, strips (40A) and, on the other side, flexible fastenings (40B) for interacting with slots (44) and with appendages (46) of said base
15 (20), and also forming stops (40C) interacting with ribs (20K) of the base (20).

1 / 14

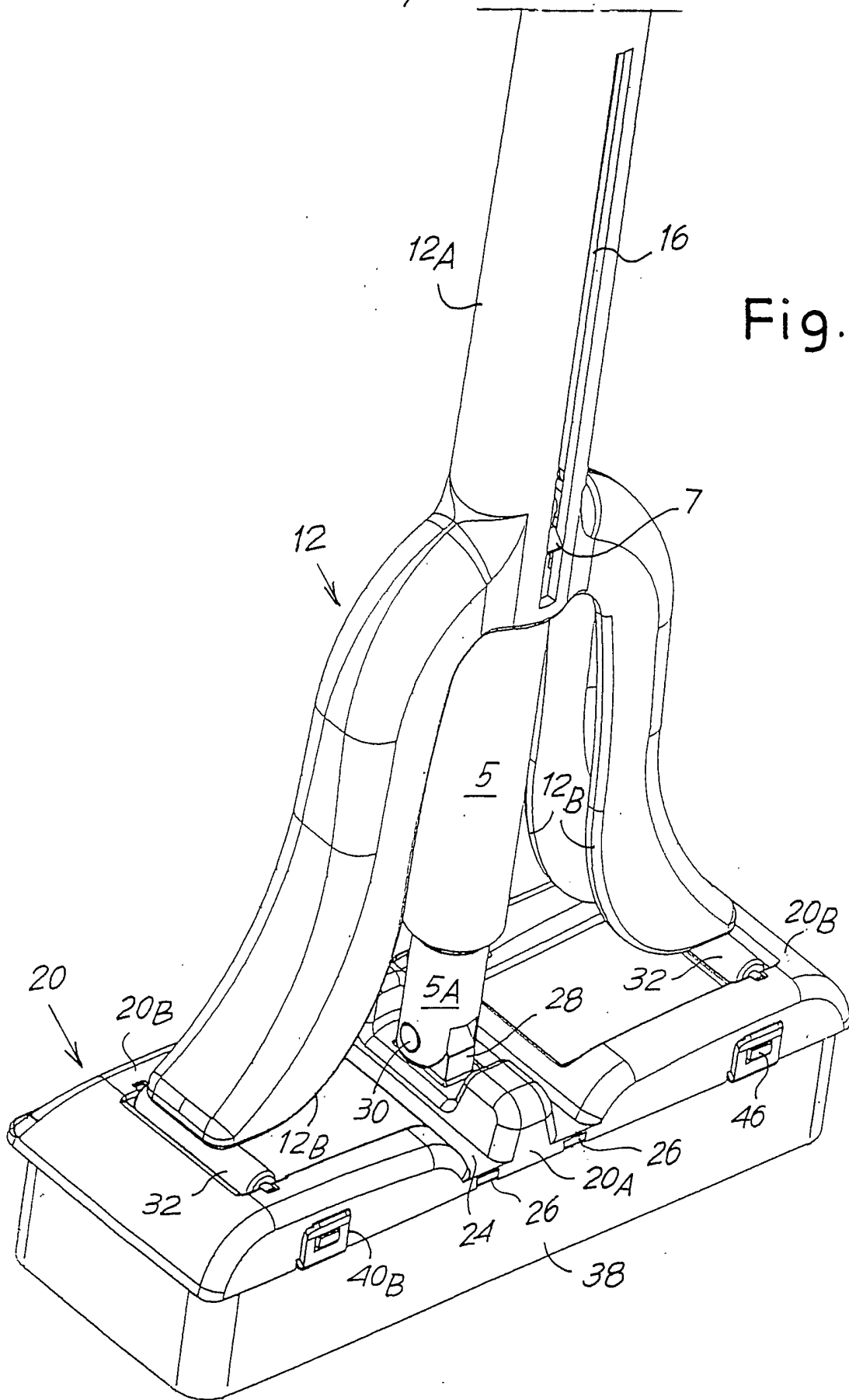
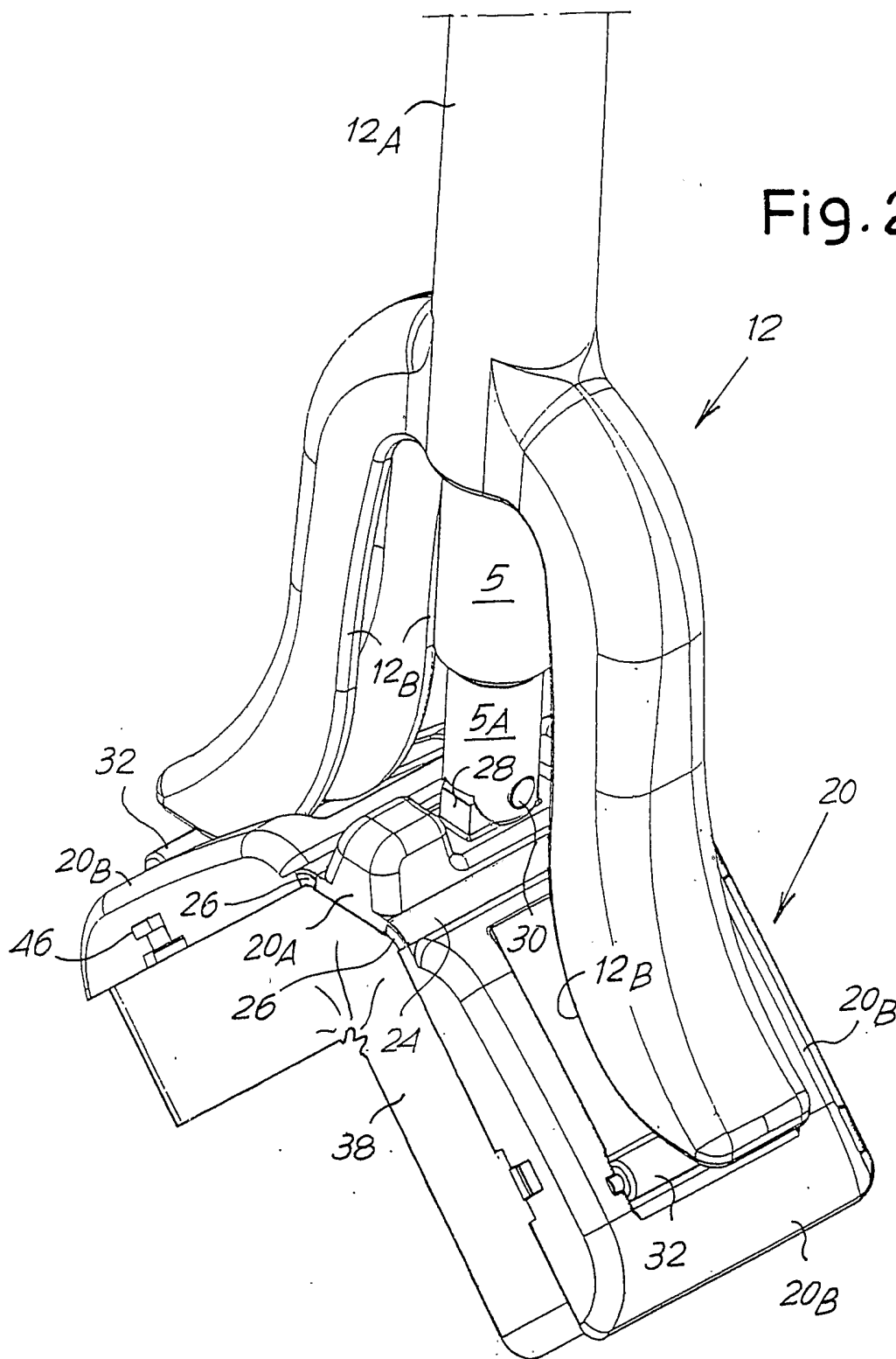

Fig. 1

Fig. 2



3 / 14

Fig. 3

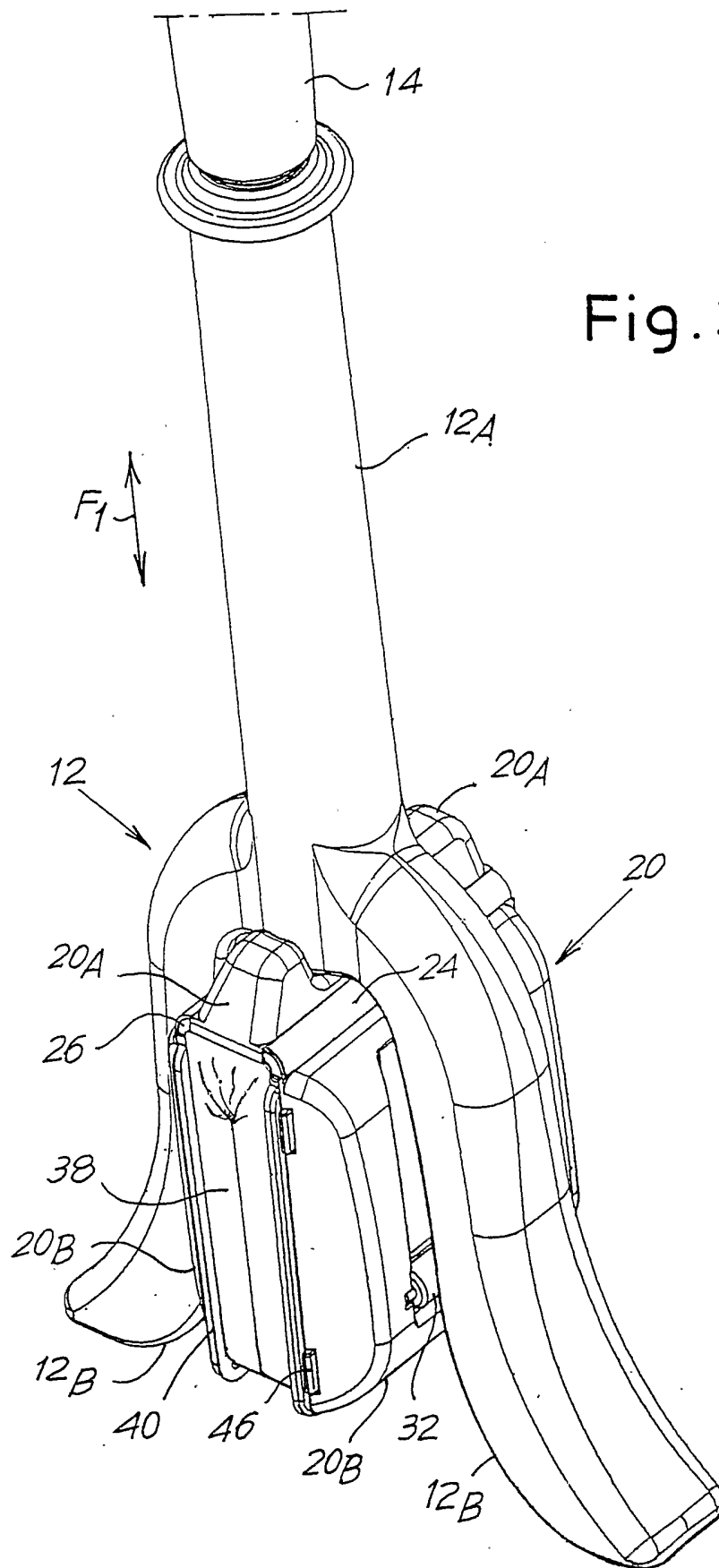

4 / 14

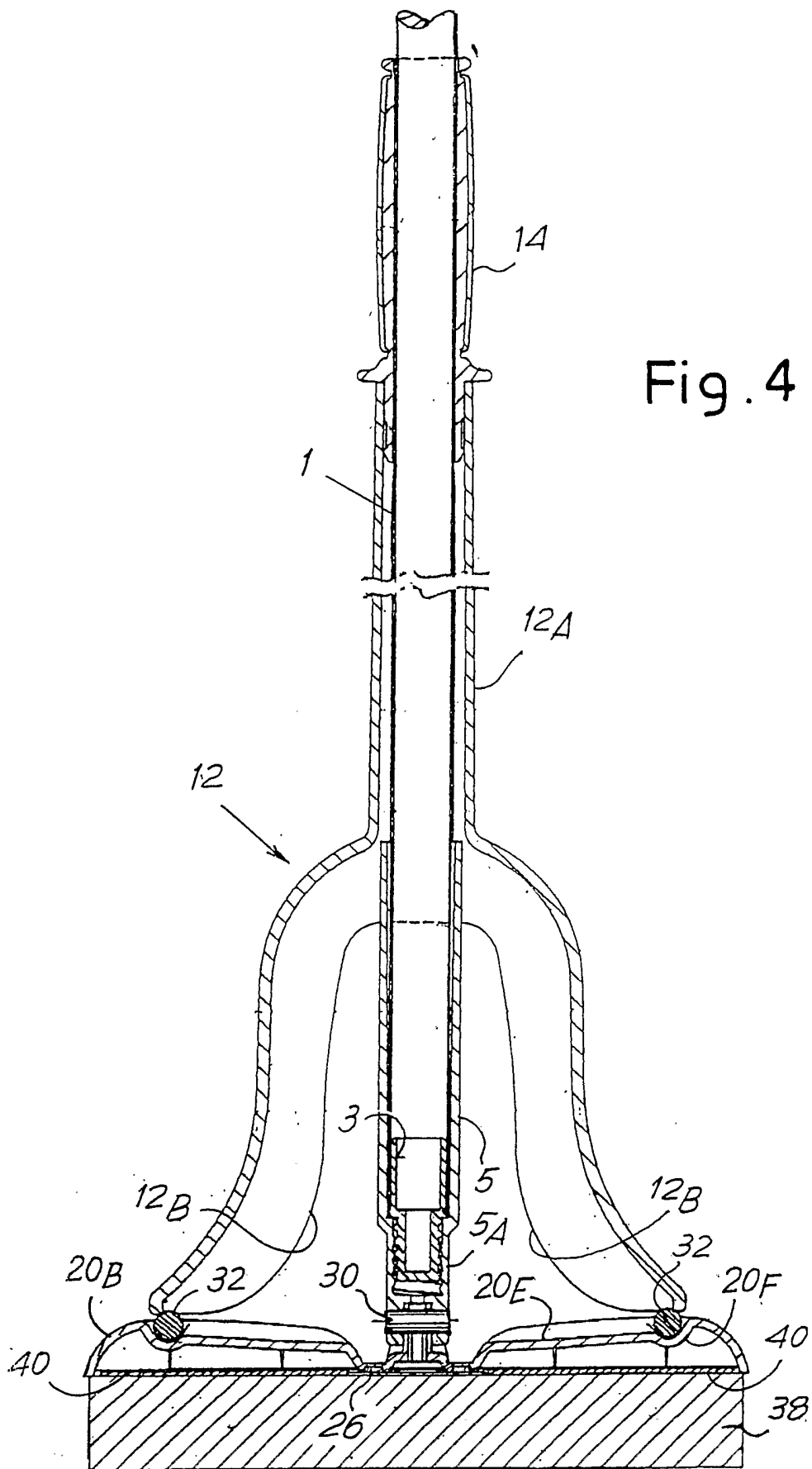

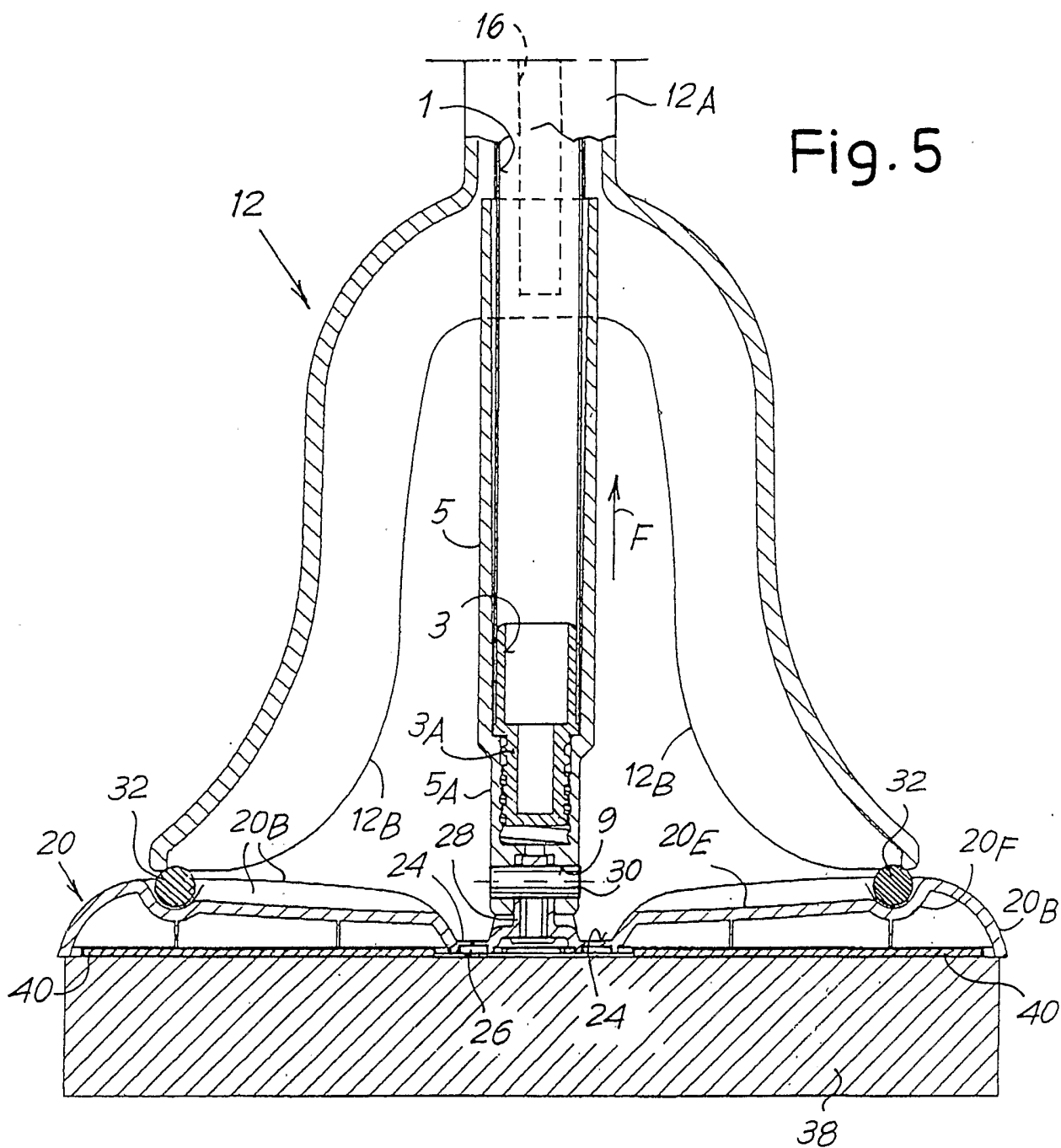
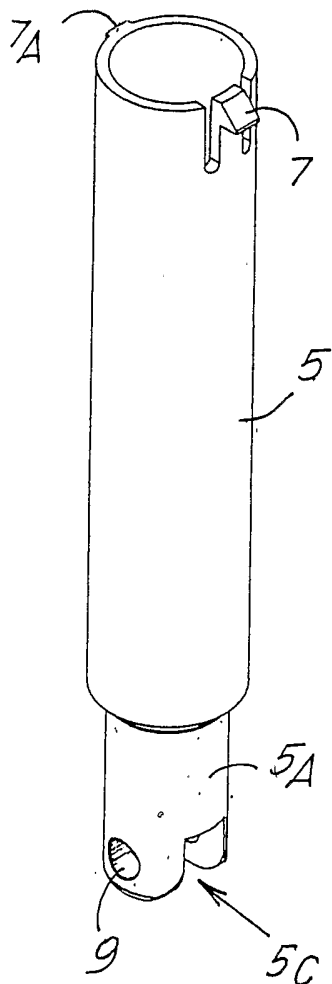

Fig.6



6 / 14

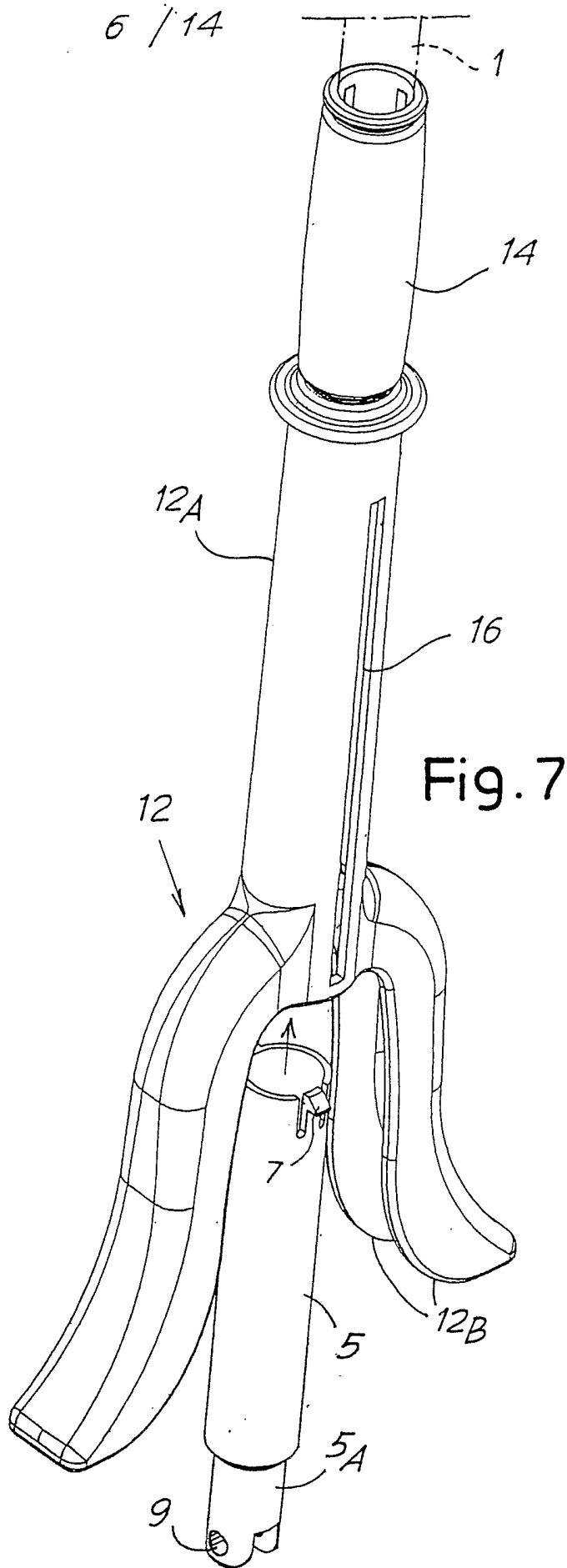

Fig.7

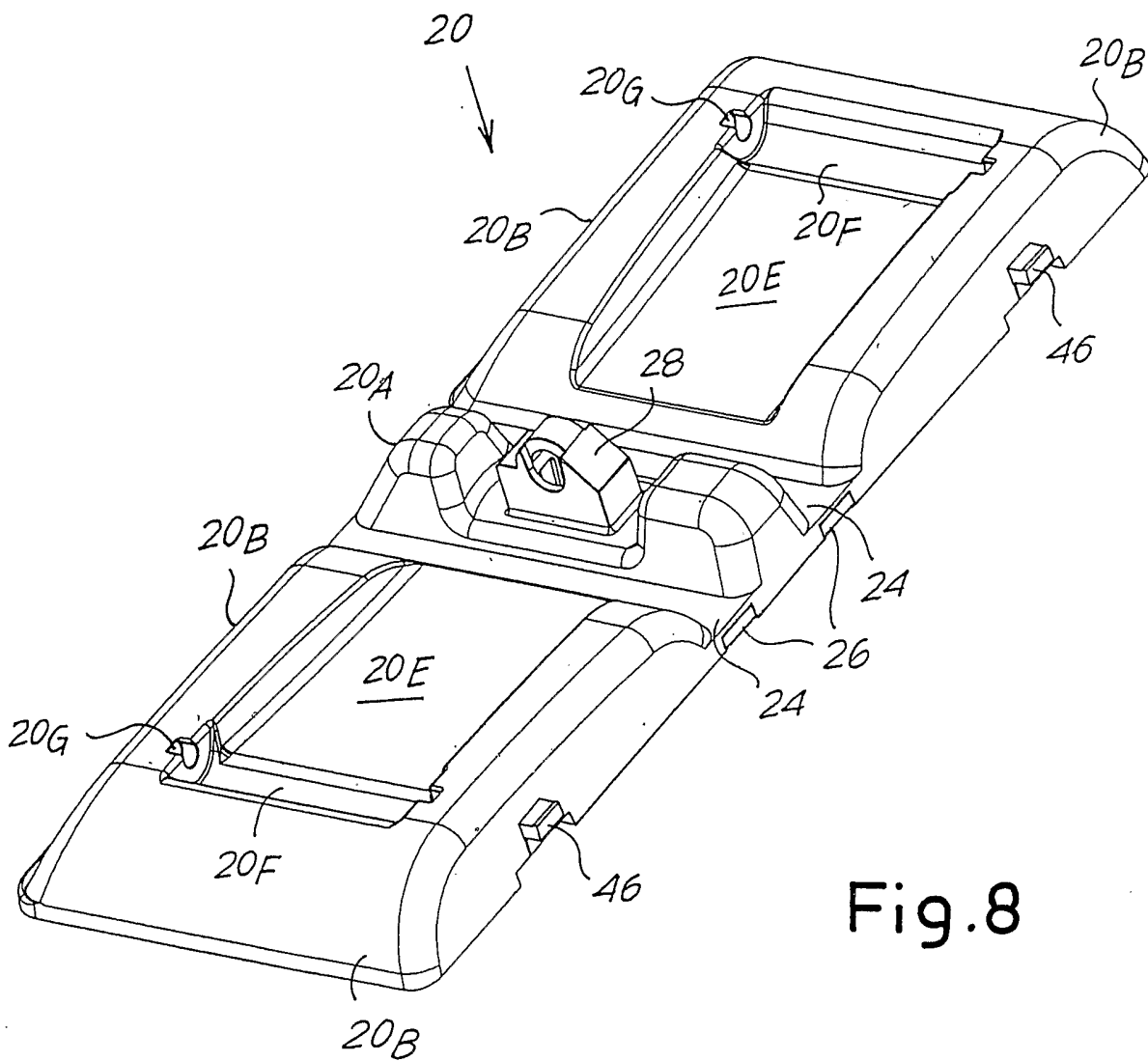
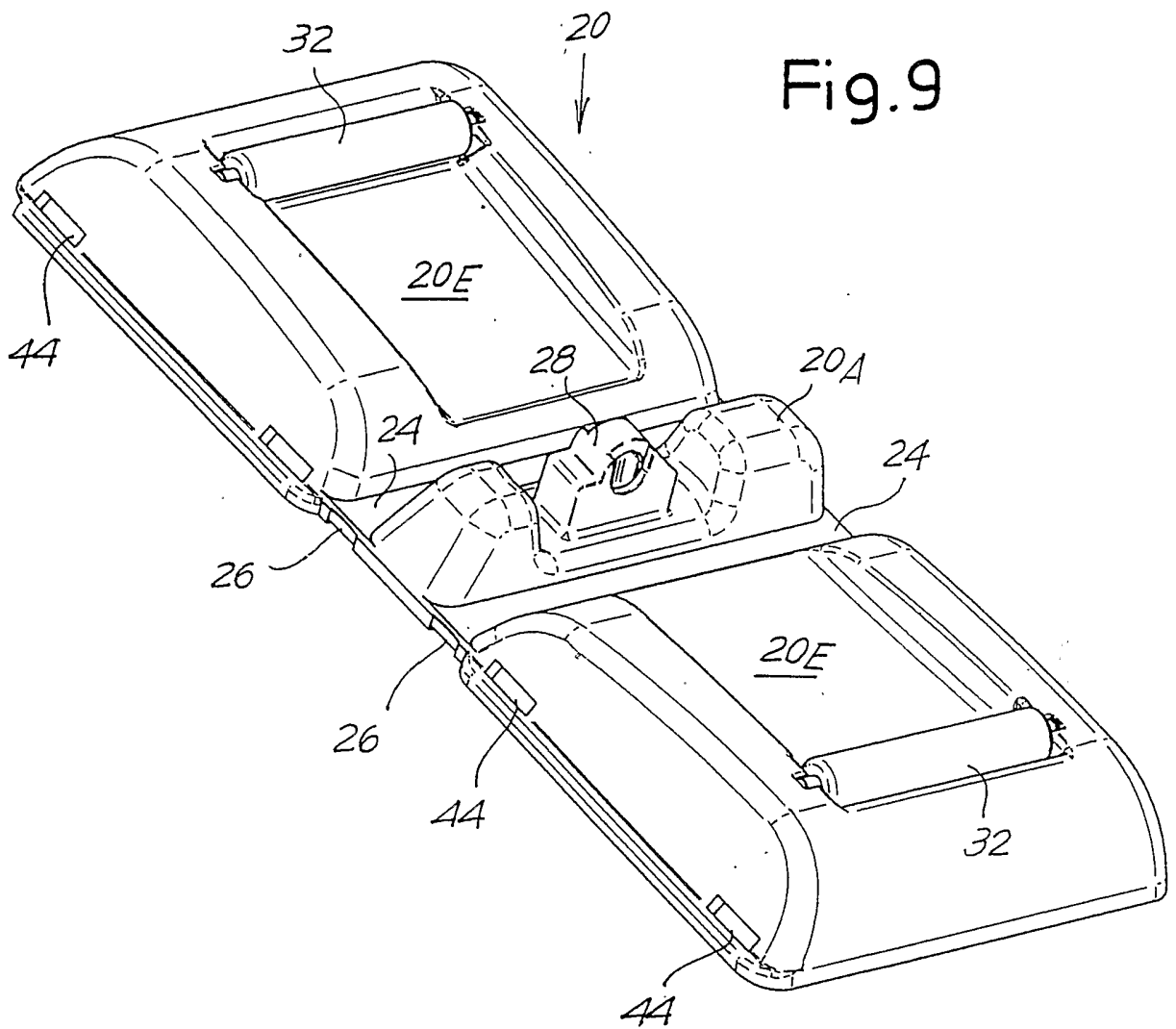

Fig.8

Fig.9



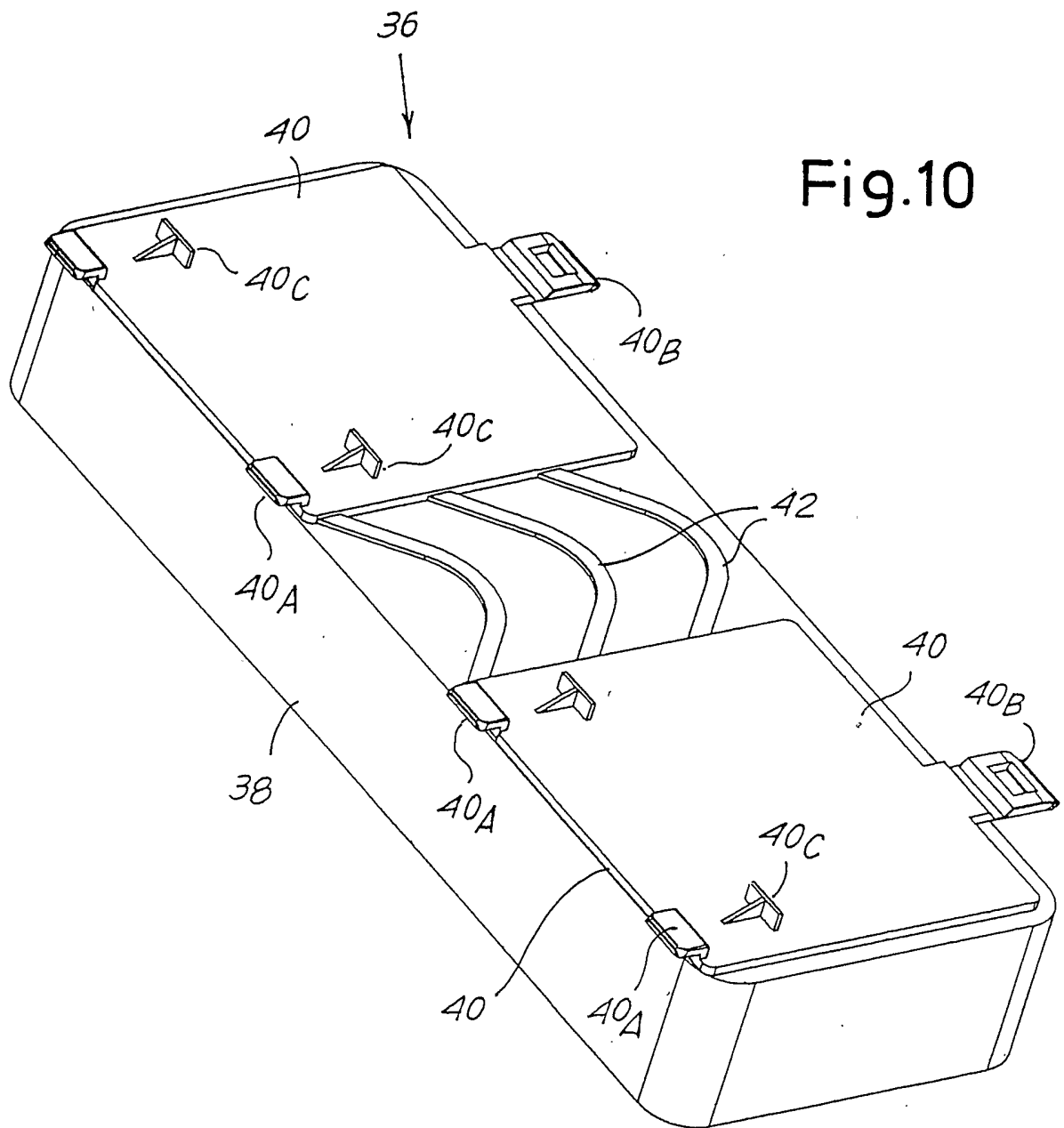
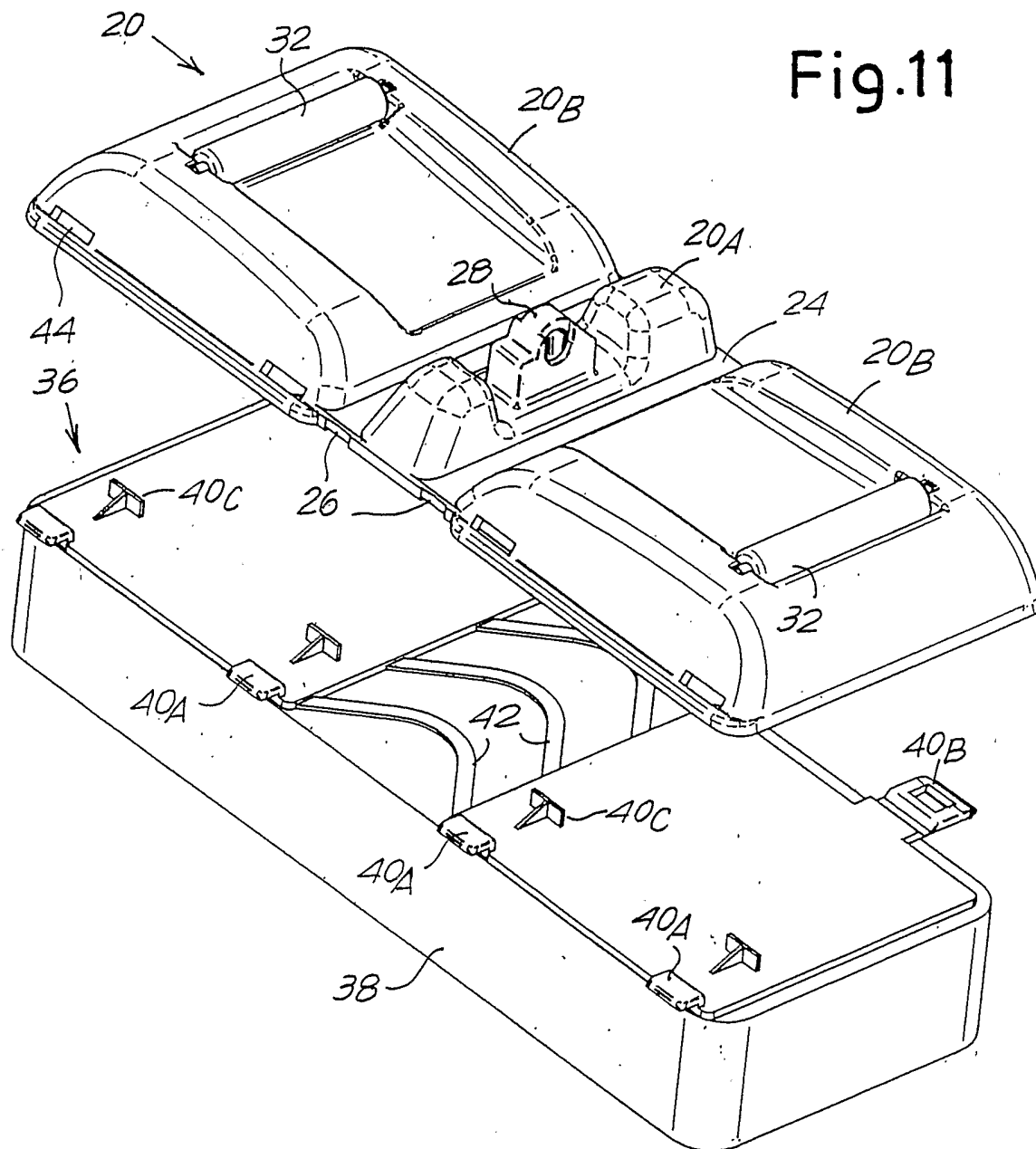
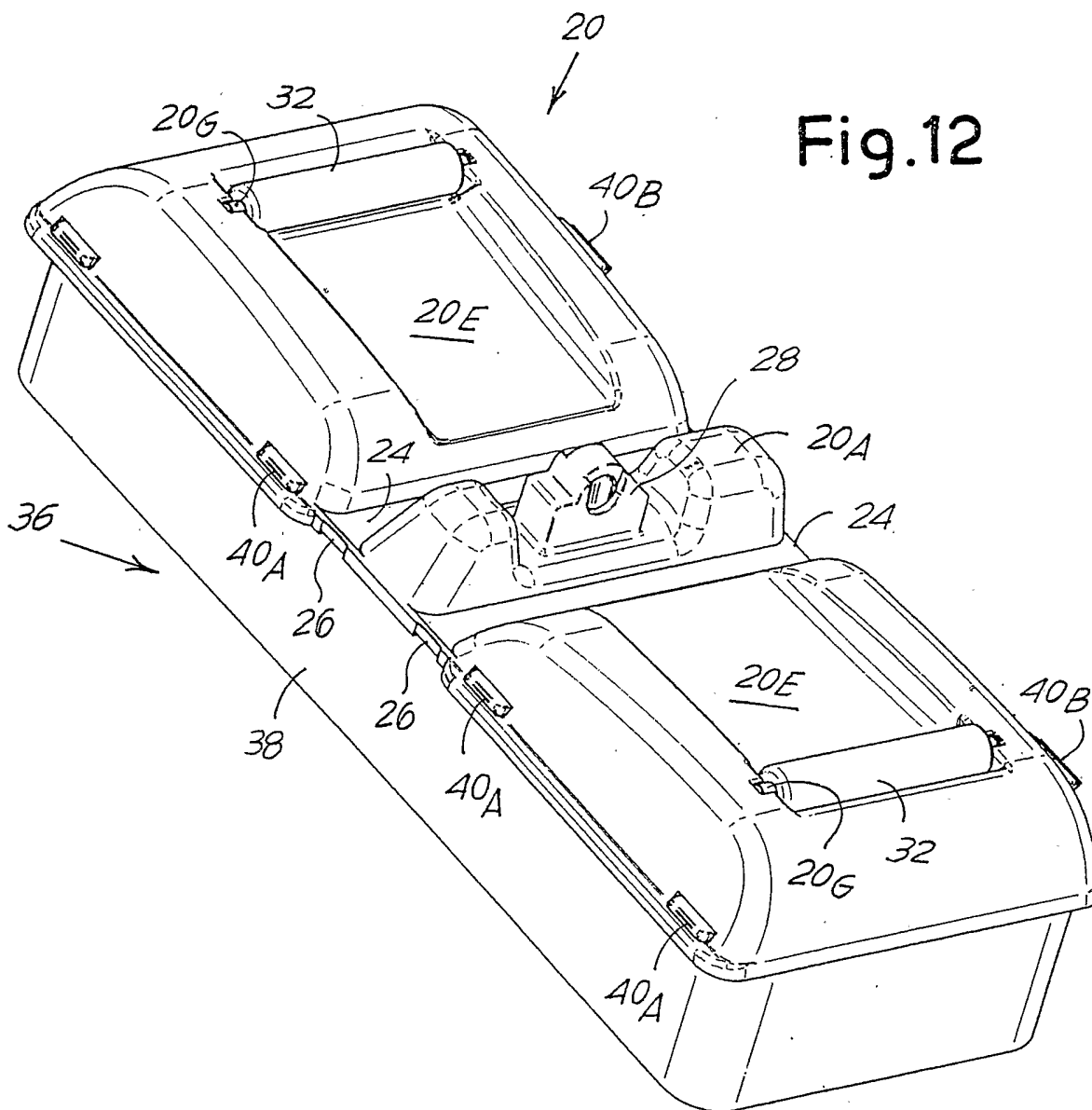

Fig.10

Fig.11





12 / 14

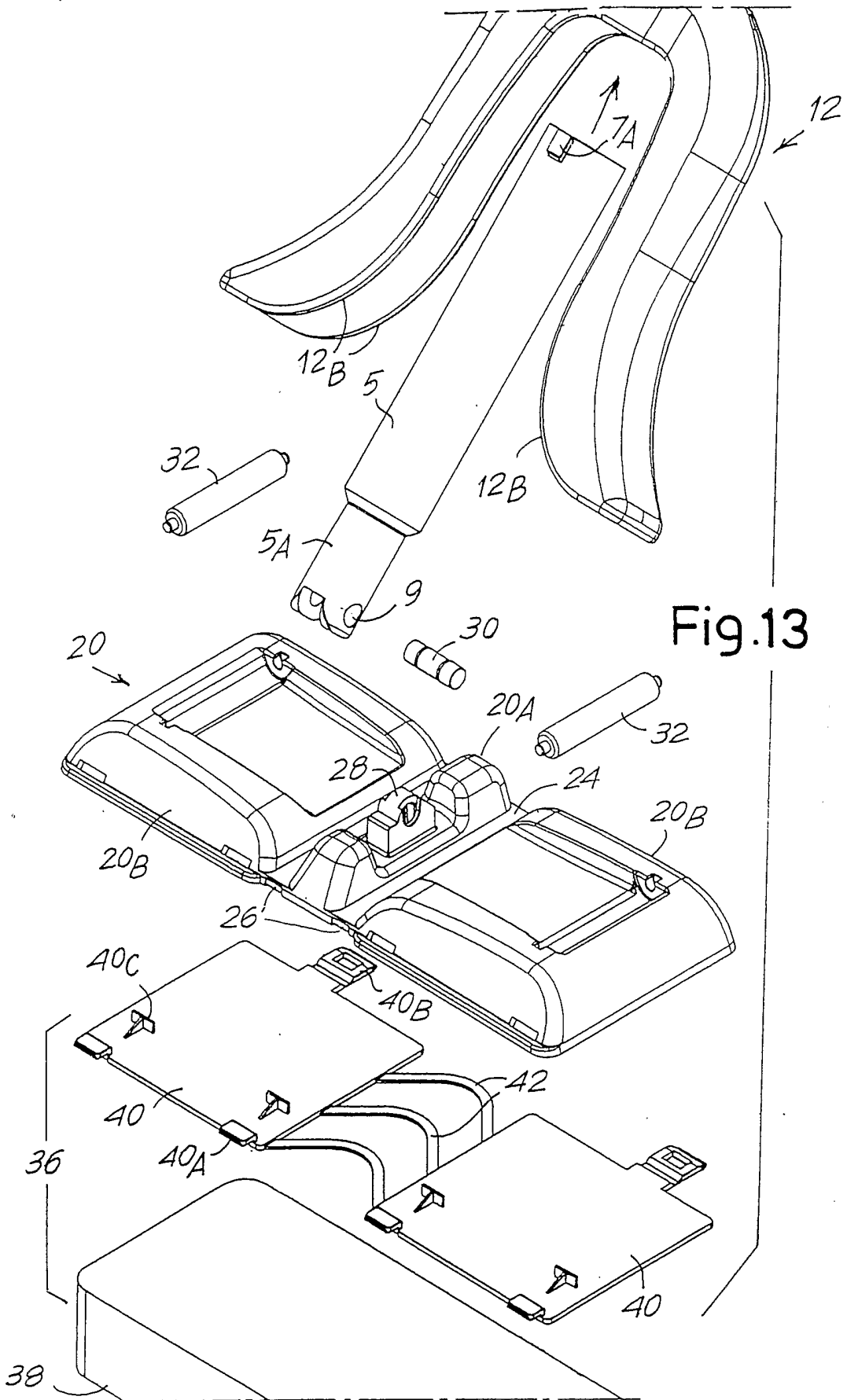
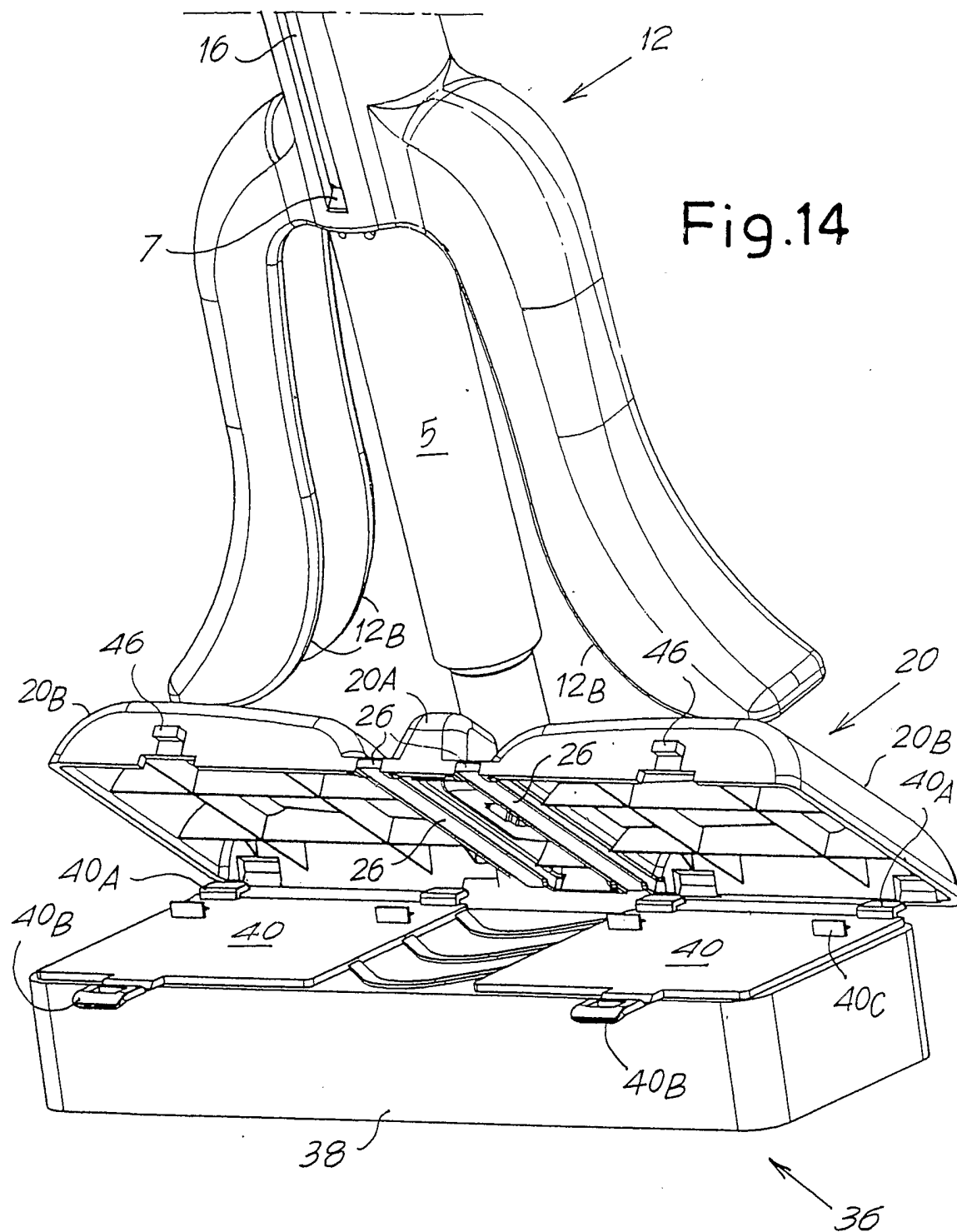

Fig.13



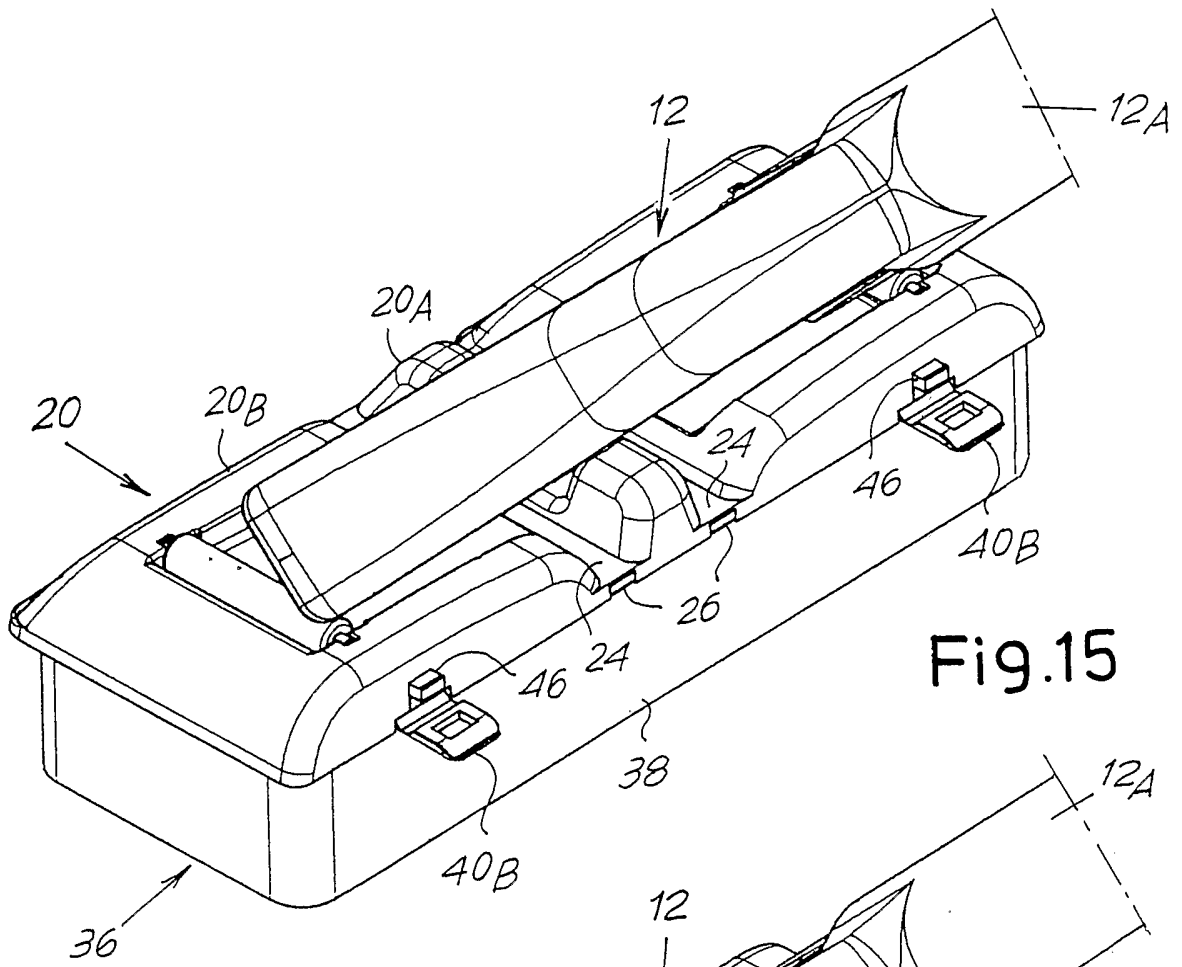

Fig.15

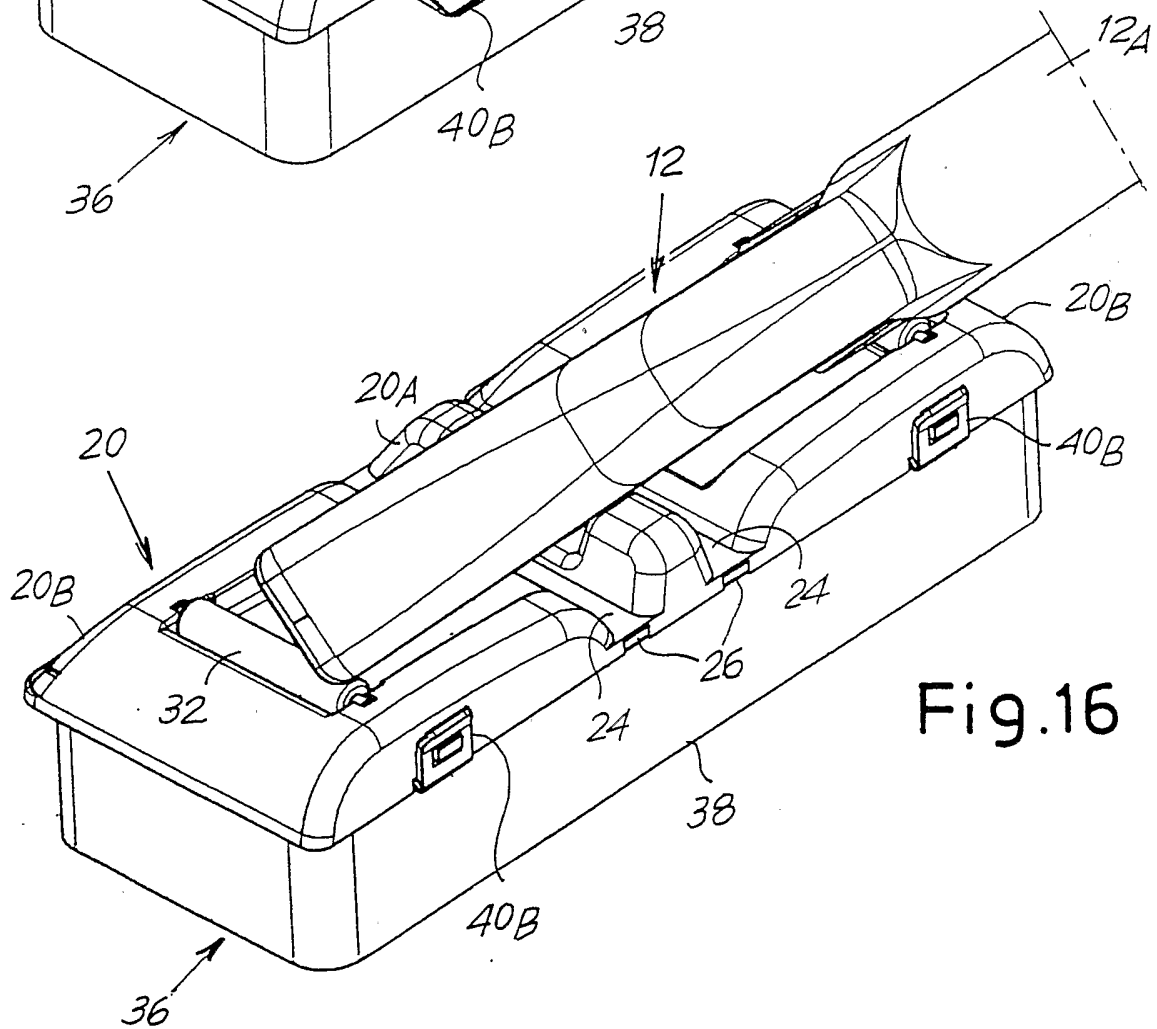

Fig.16

INTERNATIONAL SEARCH REPORT

In **International Application No**
PCT/IT 02/00802

A. CLASSIFICATION OF SUBJECT MATTER IPC 7 A47L13/146		
According to International Patent Classification (IPC) or to both national classification and IPC		
B. FIELDS SEARCHED		
Minimum documentation searched (classification system followed by classification symbols) IPC 7 A47L		
Documentation searched other than minimum documentation to the extent that such documents are included in the fields searched		
Electronic data base consulted during the international search (name of data base and, where practical, search terms used) EPO-Internal		
C. DOCUMENTS CONSIDERED TO BE RELEVANT		
Category °	Citation of document, with indication, where appropriate, of the relevant passages	Relevant to claim No.
X	EP 0 494 021 A (ELYSEES BALZAC FINANCIERE) 8 July 1992 (1992-07-08)	1, 2, 4
Y	column 3, line 41 -column 5, line 39; figures 1,2,8	3,5-7
Y	--- US 2002/056167 A1 (OHM HEINZ JOSEF ET AL) 16 May 2002 (2002-05-16) page 1, paragraph 16 - paragraph 20; figures 1,3	5,6
Y	--- BE 496 850 A (G. PIEMONT) 3 November 1950 (1950-11-03) figures 1,2	3
Y	--- GB 950 408 A (BETTERWEAR PRODUCTS LTD) 26 February 1964 (1964-02-26) figures	7
---	-/--	
<input checked="" type="checkbox"/> Further documents are listed in the continuation of box C. <input checked="" type="checkbox"/> Patent family members are listed in annex.		
° Special categories of cited documents :		
A document defining the general state of the art which is not considered to be of particular relevance *E* earlier document but published on or after the international filing date *L* document which may throw doubts on priority claim(s) or which is cited to establish the publication date of another citation or other special reason (as specified) *O* document referring to an oral disclosure, use, exhibition or other means *P* document published prior to the international filing date but later than the priority date claimed	*T* later document published after the international filing date or priority date and not in conflict with the application but cited to understand the principle or theory underlying the invention *X* document of particular relevance; the claimed invention cannot be considered novel or cannot be considered to involve an inventive step when the document is taken alone *Y* document of particular relevance; the claimed invention cannot be considered to involve an inventive step when the document is combined with one or more other such documents, such combination being obvious to a person skilled in the art. *&* document member of the same patent family	
Date of the actual completion of the international search <div style="text-align: center; font-weight: bold;">11 July 2003</div>	Date of mailing of the international search report <div style="text-align: center; font-weight: bold;">22/07/2003</div>	
Name and mailing address of the ISA European Patent Office, P.B. 5818 Patentlaan 2 NL - 2280 HV Rijswijk Tel. (+31-70) 340-2040, Tx. 31 651 epo nl, Fax: (+31-70) 340-3016	Authorized officer <div style="text-align: center; font-weight: bold;">Lodato, A</div>	

INTERNATIONAL SEARCH REPORT

International Application No
PCT/IT 02/00802

C.(Continuation) DOCUMENTS CONSIDERED TO BE RELEVANT		
Category *	Citation of document, with indication, where appropriate, of the relevant passages	Relevant to claim No.
A	US 2002/120994 A1 (HIRSE GERNOT M) 5 September 2002 (2002-09-05) the whole document ----	1-7
A	US 2002/174502 A1 (CIOCI KATHRYN) 28 November 2002 (2002-11-28) the whole document ----	1-7
A	FR 1 382 759 A (DRACKETT CO) 18 December 1964 (1964-12-18) the whole document -----	1-7

INTERNATIONAL SEARCH REPORT

Information on patent family members

International Application No

PCT/IT 02/00802

Patent document cited in search report		Publication date	Patent family member(s)	Publication date
EP 0494021	A	08-07-1992	FR 2671276 A1	10-07-1992
			DE 69104702 D1	24-11-1994
			DE 69104702 T2	08-06-1995
			EP 0494021 A1	08-07-1992
US 2002056167	A1	16-05-2002	EP 1208788 A1	29-05-2002
BE 496850	A		NONE	
GB 950408	A	26-02-1964	NONE	
US 2002120994	A1	05-09-2002	DE 10058630 C1	04-07-2002
			AU 2189102 A	03-06-2002
			CA 2363742 A1	25-05-2002
			CN 1372866 A	09-10-2002
			WO 0241744 A1	30-05-2002
			EP 1210901 A1	05-06-2002
US 2002174502	A1	28-11-2002	NONE	
FR 1382759	A	18-12-1964	NONE	